

J. OGDEN & R. C. CHILD.
 CENTRIFUGAL DISINTEGRATOR.
 APPLICATION FILED MAY 7, 1910.

967,042.

Patented Aug. 9, 1910.

2 SHEETS—SHEET 1.

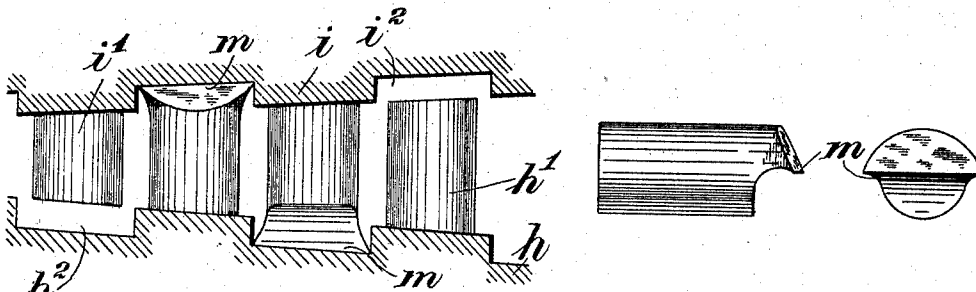

Fig. 4.

Fig. 5.

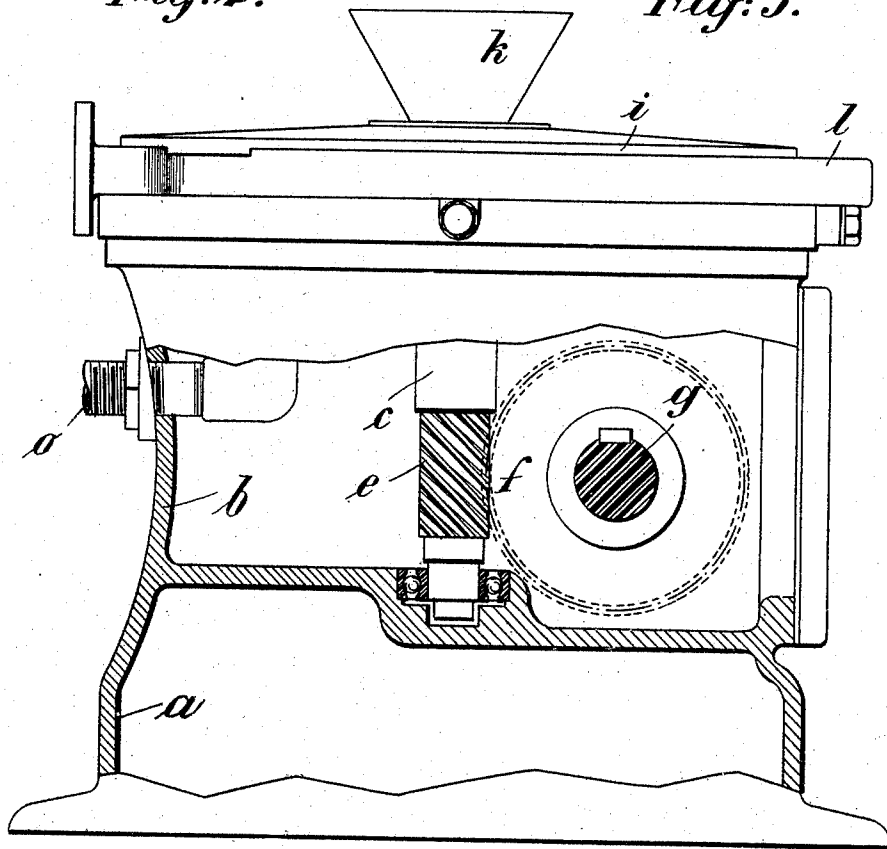

Fig. 1

WITNESSES

W. P. Burnett
 John A. Percival

INVENTORS

Joseph Ogden
 Robert C. Child
 BY *Wm. M. Sullivan* ATTORNEY

J. OGDEN & R. C. CHILD.
 CENTRIFUGAL DISINTEGRATOR.
 APPLICATION FILED MAY 7, 1910.

967,042.

Patented Aug. 9, 1910.

2 SHEETS—SHEET 2.

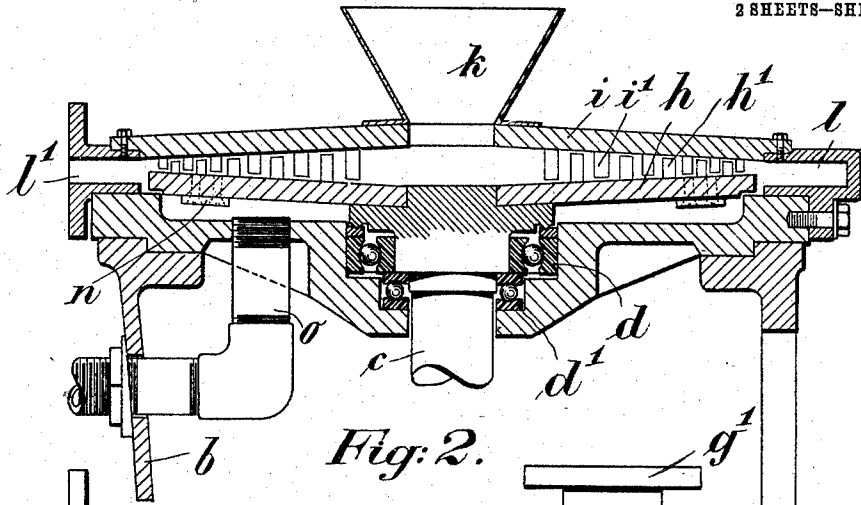

Fig: 2.

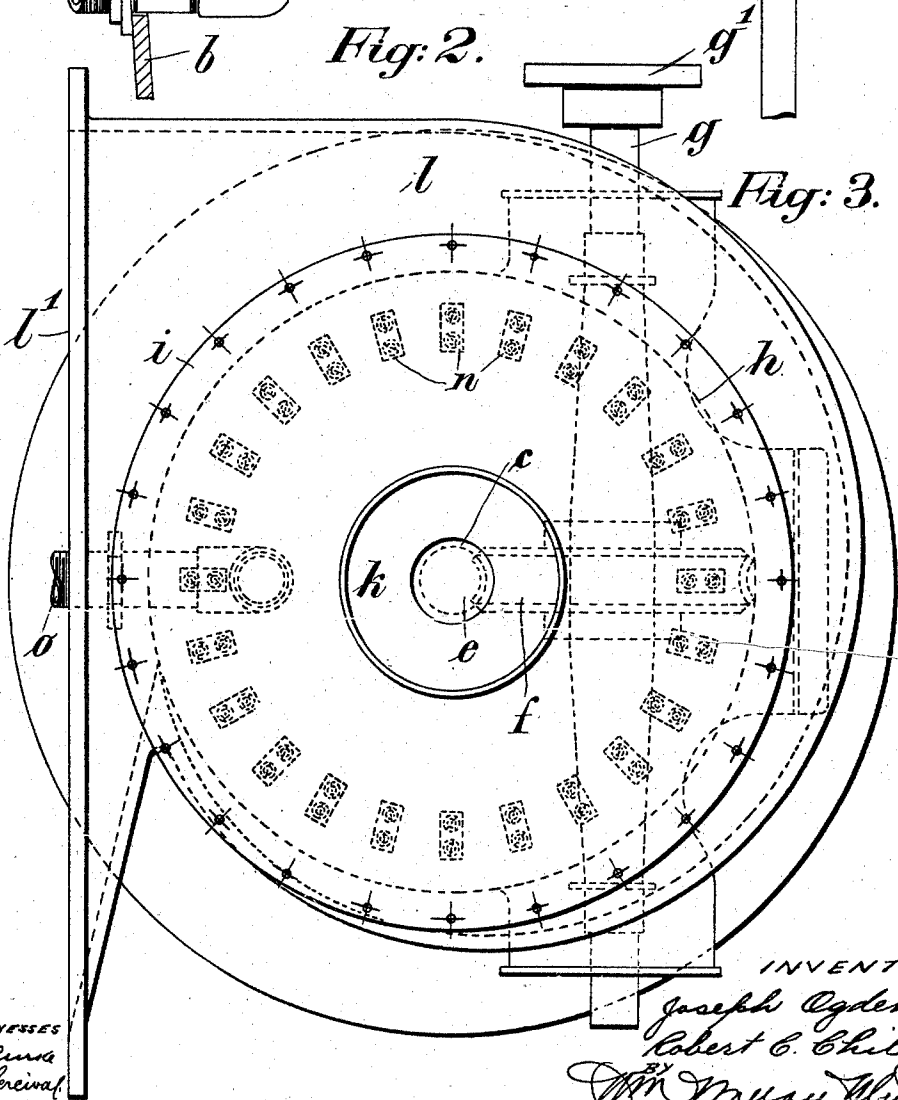

Fig: 3.

WITNESSES
 W. R. R. R.
 J. A. R. R.

INVENTORS
 Joseph Ogden
 Robert C. Child
 Wm. M. M. M.

UNITED STATES PATENT OFFICE.

JOSEPH OGDEN, OF SALFORD, AND ROBERT CARLYLE CHILD, OF LONDON, ENGLAND,
ASSIGNORS TO SAID ROBERT CARLYLE CHILD, OF LONDON, ENGLAND.

CENTRIFUGAL DISINTEGRATOR.

967,042.

Specification of Letters Patent.

Patented Aug. 9, 1910.

Application filed May 7, 1910. Serial No. 559,912.

To all whom it may concern:

Be it known that we, JOSEPH OGDEN and ROBERT CARLYLE CHILD, subjects of the King of Great Britain and Ireland, residing, respectively, at Parkside avenue, Leicester Road, Salford, Lancashire, and 11 Queen Victoria street, London, England, have invented new and useful Improvements in Centrifugal Disintegrators, of which the following is a specification.

This invention relates to that class of disintegrators in which disks are used provided with projecting pegs or studs so that in operation the ring of pegs on one disk rotates between the ring of pegs on the opposite disk, and has for its object the provision of means whereby the difficulties with regard to the packing of the material in the disintegrator are overcome and also the presence of dust between the working parts is avoided in order that frictional resistance may be reduced to a minimum, and unnecessary wear and tear of the rotating parts be avoided.

In disintegrators of the above description it has been found that the material under treatment collects on those parts of the moving and stationary disks which are situated immediately opposite the ends of the projecting pins and causes not only a high frictional resistance but interferes with the travel of the material outward through the successive rings of pegs. Further that the material is liable to pack in the delivery chamber and to interfere materially with the function of the machine and further where the revolving disks have to move in close proximity to the casing great difficulty is experienced owing to the higher pressure of the atmosphere within the disintegrator when in operation compared with the outside in preventing the fine material from getting through the space between the periphery of the disk and the casing and coming in contact with the bearings and journals for supporting the rotating disk. The disintegrating efficiency of this class of machine depends upon the velocity transmitted to the particles to be dealt with hence a high rate of revolution is necessary, say a peripheral velocity of disk of from 15,000 to 20,000 feet per minute and mechanical difficulties have arisen in obtaining such velocity from ordinary sources of power. All these difficulties are entirely overcome by our invention.

In order that this invention may be the better understood, we will now proceed to describe the same, reference being had to the accompanying drawings.

Like letters refer to like parts in the various figures.

Figure 1 is a part sectional elevation of a machine constructed in accordance with our invention. Fig. 2 is a sectional elevation of the upper part of the machine showing the stationary and revolving disks, and the method of mounting the latter. Fig. 3 is a plan of the machine showing the delivery casing of volute form. Fig. 4 is a detail view showing the modified arrangement of pins. Fig. 5 shows two views of the modified pins.

Upon a suitable frame *a* a gear box *b* is mounted or is constructed integral therewith, such gear box being of entirely closed character so as to contain a bath of oil.

Within the box *b* a vertical shaft *c* is mounted in ball bearings *d* and footstep bearings *d*¹. This shaft *c* is provided with worm gearing *e* into which gears a worm wheel *f* mounted on the first motion shaft *g*, the said shaft being driven from any suitable source of power by the coupling *g*¹ mounted on the external end thereof or by any other equivalent and known means.

On the upper part of the shaft *c* and external to the box *b* is mounted a rotating disk *h* having a series of pins *h*¹ extending upwardly. Immediately over the revolving disk *h* is a cover *i* having pins *i*¹ interspaced between the pins *h*¹ on the revolving disk *h*.

The feeding hopper *k* is disposed in the center of the cover *i* while the delivery of the material takes place from the disk into the delivery chamber *l* formed of volute shape, similar to the casing of a centrifugal pump; the final delivery takes place through the orifice *l*¹ at one side of the chamber *l*.

The disks *h* and *i* may be initially formed with grooves *h*² and *i*² or such grooves may become formed during the working of the machine by the attrition of the material. In order to prevent the accumulation of material in these grooves and to continuously clear the same, one or more of the pins *h*¹ and *i*¹ in each ring of pins is adapted to project into the grooves so that the ends of such pins move in close proximity to the bottom surface of the said grooves. The end of each of the said pins *i*¹ or *h*¹ is

formed with a scraping or cutting edge m adapted to readily disturb the layer of material which may lie in the particular groove in which it works.

5 Difficulties have arisen with regard to the access of dust to the upper ball bearings of machines of this type, we therefore to avoid such difficulties provide on the under-
10 side of the disk h means, such as a series of blades or projections n which will when the disk h is in rotation produce an air current in an outward direction in a similar manner to a fan.

The space below the disk h is provided
15 with means such as a pipe o through which air can be taken from the exterior of the machine and from a source uncontaminated by dust or other undesirable matter, such
20 air being drawn into the machine by the action of the blades n and being delivered from the discharge orifice l' so as to continuously carry away from the disintegrator, material discharged from the chamber l .
25 At the same time the direction of the current of air below the disk h prevents any of the ground material from having access to the ball bearings d or d' . In this way the atmosphere around the bearings is main-

tained absolutely free from dust and at the same time any clogging of the material be- 30
tween the rotating disk h and the stationary casing l is entirely avoided.

Claims:

1. In a disintegrating machine, stationary and revolving disks provided with grooves, 35
pins projecting from said disks arranged in rings and some of said pins in each ring being longer than the other pins in said ring so as to project into the grooves.

2. A disintegrating machine comprising 40
stationary and revolving disks, and pins arranged in rings projecting from said disks the pins on the respective disks being interspaced relatively to one another, and
45 some of the pins of each ring being longer than the others in said ring and said long pins having cutting edges.

In testimony whereof we have signed our names to this specification in the presence of two subscribing witnesses.

JOSEPH OGDEN.

ROBERT CARLYLE CHILD.

Witnesses:

RICHARD A. HOFFMANN,

CHARLES J. R. BULLOUGH.