

(19) World Intellectual Property Organization
International Bureau



(43) International Publication Date
26 June 2008 (26.06.2008)

PCT

(10) International Publication Number
WO 2008/076830 A3

- (51) International Patent Classification:
B01D 15/08 (2006.01) *G01N 30/02* (2006.01)
- (21) International Application Number:
PCT/US2007/087434
- (22) International Filing Date:
13 December 2007 (13.12.2007)
- (25) Filing Language: English
- (26) Publication Language: English
- (30) Priority Data:
60/869,819 13 December 2006 (13.12.2006) US
- (71) Applicant (for all designated States except US):
BIO-RAD LABORATORIES, INC. [US/US]; 1000 Alfred Nobel Drive, Hercules, California 94547 (US).
- (72) Inventors; and
- (75) Inventors/Applicants (for US only): **BAILEY, Daniel, M.** [US/US]; 91 Seabury, Hampton, New Hampshire 03842 (US). **VERNOT, Philippe** [FR/FR]; La Jassolle

- Aulhat, F-63500 Saint Privat (FR). **LEFEBVRE, Sebastien** [FR/FR]; Rue des Farges, F-63450 Saint Saturnin (FR).
- (74) Agents: **HEINES, M., Henry** et al.; Townsend and Townsend and Crew LLP, Two Embarcadero Center, 8th Floor, San Francisco, California 94111 (US).
- (81) Designated States (unless otherwise indicated, for every kind of national protection available): AE, AG, AL, AM, AT, AU, AZ, BA, BB, BG, BH, BR, BW, BY, BZ, CA, CH, CN, CO, CR, CU, CZ, DE, DK, DM, DO, DZ, EC, EE, EG, ES, FI, GB, GD, GE, GH, GM, GT, HN, HR, HU, ID, IL, IN, IS, JP, KE, KG, KM, KN, KP, KR, KZ, LA, LC, LK, LR, LS, LT, LU, LY, MA, MD, ME, MG, MK, MN, MW, MX, MY, MZ, NA, NG, NI, NO, NZ, OM, PG, PH, PL, PT, RO, RS, RU, SC, SD, SE, SG, SK, SL, SM, SV, SY, TJ, TM, TN, TR, TT, TZ, UA, UG, US, UZ, VC, VN, ZA, ZM, ZW.
- (84) Designated States (unless otherwise indicated, for every kind of regional protection available): ARIPO (BW, GH, GM, KE, LS, MW, MZ, NA, SD, SL, SZ, TZ, UG, ZM,

[Continued on next page]

(54) Title: SUPPORTING STRUCTURES FOR PREPARATIVE CHROMATOGRAPHY COLUMNS

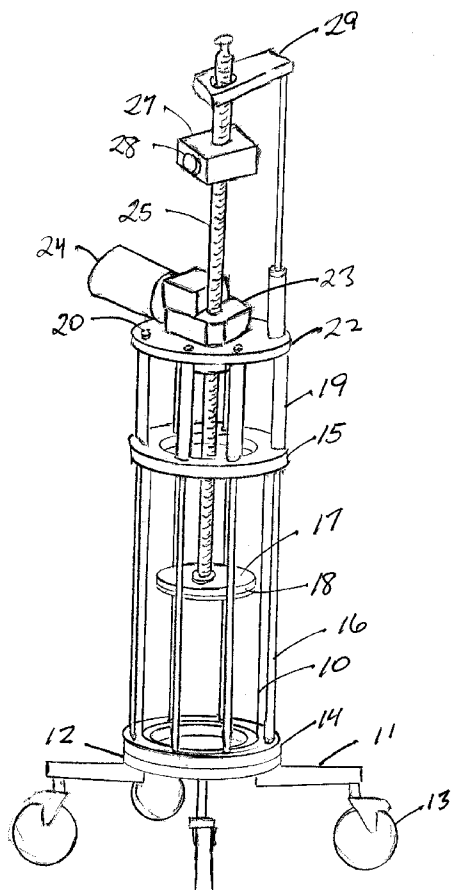

(57) Abstract: The plunger used as the upper enclosure in a preparative chromatography column is suspended by one or more rods that are supported by a frame through coupling connections on the frame that can fix the position of the rod(s) relative to the frame, while the position of the rod(s) is controlled by a motorized drive system that is suspended above the column. The drive system is mounted either to the column lid or to a functional plate positioned a short distance above the column lid. These constructions allow the plunger to be raised and lowered so that the column and its parts can be exchanged, all without the need for a hoist or crane.

WO 2008/076830 A3



ZW), Eurasian (AM, AZ, BY, KG, KZ, MD, RU, TJ, TM),
European (AT, BE, BG, CH, CY, CZ, DE, DK, EE, ES, FI,
FR, GB, GR, HU, IE, IS, IT, LT, LU, LV, MC, MT, NL, PL,
PT, RO, SE, SI, SK, TR), OAPI (BF, BJ, CF, CG, CI, CM,
GA, GN, GQ, GW, ML, MR, NE, SN, TD, TG).

— *with amended claims and statement*

(88) Date of publication of the international search report:
14 August 2008

Published:

— *with international search report*

Date of publication of the amended claims and statement:
2 October 2008

AMENDED CLAIMS**received by the International Bureau on 05 June 2008****WHAT IS CLAIMED IS:**

1. A combination preparative chromatography column and column support, comprising:
 - a column tube having a removable tube cover and a removable tube base;
 - a plunger suspended by a plurality of rods;
 - a frame configured to detachably engage said rods; and
 - a single motor mounted to said tube cover for moving said plurality of rods simultaneously and vertically to vary the position of said plunger within said column tube.
2. The combination of claim 1 wherein said plurality of rods are supported by a common coupling plate, and said frame is configured to detachably engage said rods through said coupling plate.
3. The combination of claim 1 wherein said frame comprises a horizontal bar supported by vertical supports of extendable height.
4. A column support for a preparative chromatography column, said column support comprising:
 - an upper ring and a lower ring aligned along a common axis and joined to each other by peripheral spacing means to define a column space to receive a chromatography column between said rings;
 - a plate detachably joinable to said upper ring in parallel relation therewith to define a gap between said plate and said upper ring;
 - a rod movably joined to said plate along said axis, said rod passing through said plate and terminating in a plunger that extends into said column space when said plate and said upper ring are joined;
 - drive means for moving said rod along said axis and thereby moving said plunger within said column space and between said column space and said gap when said plate and said upper ring are joined; and
 - means for suspending said plate from a frame to allow a first upper and lower ring combination sized for a chromatography column of a first diameter that is joined to said plate through said upper ring to be detached from said plate, removed and

replaced by a second upper and lower ring combination sized for a chromatography column of a second diameter different from the first, without changing said plate.

5. The column support of claim 4 wherein said rod is hollow and has a threaded exterior surface, and said drive means comprises a motor and gear box affixed to said plate to form a worm gear with said rod.

6. The column support of claim 4 wherein said peripheral spacing means comprises a series of parallel posts joining, and distributed around the peripheries of, said upper and lower rings.

7. The column support of claim 6 wherein said upper ring of said first ring combination, defined as a first upper ring, and said upper ring of said second ring combination, defined as a second upper ring, have equal outer diameters but differently positioned mounting sites for said posts such that posts joined to said second upper ring are closer to said axis than posts joined to said first upper ring.

8. The column support of claim 4 wherein said plunger comprises an inflatable peripheral gasket.

9. The column support of claim 8 wherein said inflatable peripheral gasket is inflated by a pneumatic supply mounted on said frame.

10. The column support of claim 4 wherein said drive means defines a path of travel of said rod along said axis and said column support further comprises means for limiting said path of travel.

This statement is submitted in response to the International Search Report and Written Opinion mailed on 29 April 2008, and accompanies an amendment to the claims in accordance with the attached replacement sheets.

In the amendment, claim 2 has been incorporated into claim 1, and the remaining claims have been renumbered. Claim 1 as amended recites an invention that is both novel and an inventive step over the combined disclosures of Perreault et al. (US 2006/0196832) and Hatch et al. (US 6,001,260 A), and the combined disclosures of Perreault et al., Hatch et al., and Mann. Neither Perreault et al. nor Hatch et al. discloses or suggests a plunger that is suspended by a plurality of rods and a single motor that is mounted to a tube cover and that moves the rods simultaneously. Mann (US 6,736,974 B1) is cited as disclosing a plurality of rods driven by a single motor, but in reality what Mann discloses is a plurality of individual hydraulic cylinders (34) each with its own individual piston (36). The plunger (20) in the Mann structure is not suspended by the pistons (36) but instead by rigid suspending rods (not numbered) that are fixedly bolted to "connection arms" (40, FIG. 5). The column (10) does not have a tube cover, as presently claimed by Applicants, much less one to which the hydraulic cylinder is mounted. With these missing features, there is no

suggestion in any of the three these references, taken either alone or in combination, of the simple and effective structure claimed by Applicants as the invention of claim 1.

Former claim 5, renumbered by the present amendment as claim 4, is both novel and inventive over the disclosure of Hatch et al. (US 6,001,260 A). The structure disclosed by Hatch et al. does not include an upper ring, but instead a pair of blocks (64, 66) connected by “cross members” (68, 70). The “moveable support member” (18) of Hatch et al. has been cited as the counterpart to the “plate” of Applicant’s claim, but the “moveable support member” is not “joinable to said upper ring ... to define a gap between said plate and said upper ring” as Applicants claim. Instead, the “moveable support member” (18) is joinable to the blocks (64, 66) in a direct connection only, with no gap. The Hatch et al. disclosure also lacks a “frame” to correspond to the frame recited in Applicants’ claim, and likewise lacks a “means for suspending said plate from a frame” as Applicants claim. Accordingly, the Hatch et al. structure fails to offer a means by which one can exchange column supports of different sizes without dismantling the entire structure.

The remaining claims are all dependent on claims 1 and 4, and all recite inventions that are both novel and an inventive step in view of the novelty and inventive nature of the inventions of claims 1 and 4.