

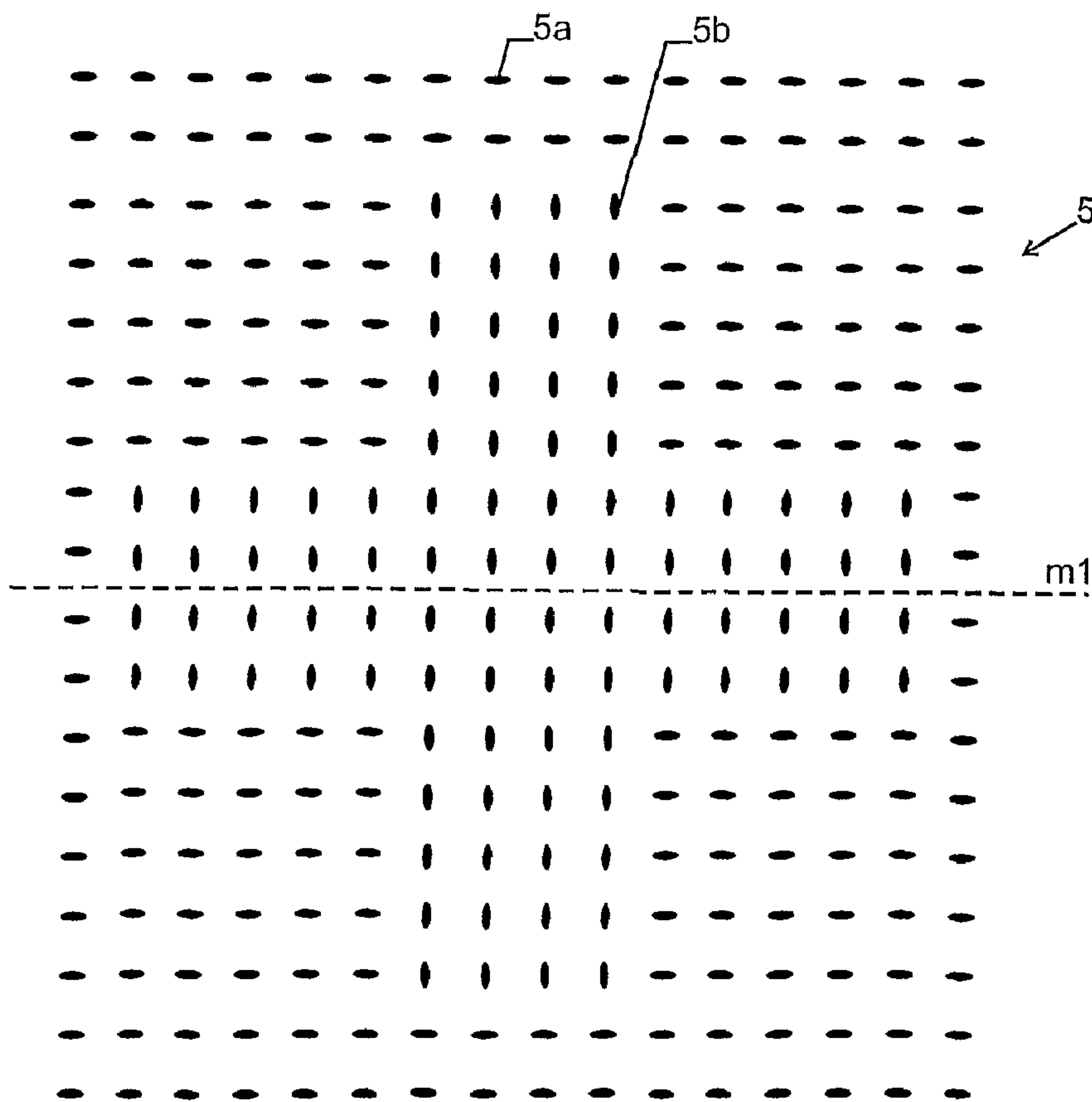

(86) Date de dépôt PCT/PCT Filing Date: 2002/07/25
 (87) Date publication PCT/PCT Publication Date: 2004/02/05
 (45) Date de délivrance/Issue Date: 2011/05/03
 (85) Entrée phase nationale/National Entry: 2005/01/25
 (86) N° demande PCT/PCT Application No.: IB 2002/002914
 (87) N° publication PCT/PCT Publication No.: 2004/011274

(51) Cl.Int./Int.Cl. *B42D 15/00* (2006.01)
 (72) Inventeurs/Inventors:
 VON FELLEBERG, IAN DANIEL, DE;
 SCHERTENLEIB, BEAT ROLAND, CH
 (73) Propriétaire/Owner:
 ORELL FUESSLI SICHERHEITSDRUCK AG, CH
 (74) Agent: MARKS & CLERK

(54) Titre : DOCUMENT SECURISE ET PROCEDE DE VERIFICATION
 (54) Title: SECURITY DOCUMENT AND VERIFICATION METHOD



(57) Abrégé/Abstract:

A security document, such as a banknote or a cheque, is provided with a perforation pattern (5) having holes (5a, 5b) with elongate cross section. When viewing the perforation pattern (5) from a direction that is non-perpendicular to the surface of the document,

(57) **Abrégé(suite)/Abstract(continued):**

different holes will have different optical transmission, which can be verified by eye or electronically. Perforation patterns (5) of this type are hard to forge and easy to verify.

(12) INTERNATIONAL APPLICATION PUBLISHED UNDER THE PATENT COOPERATION TREATY (PCT)

(19) World Intellectual Property
Organization
International Bureau



(43) International Publication Date
5 February 2004 (05.02.2004)

PCT

(10) International Publication Number
WO 2004/011274 A1

(51) International Patent Classification⁷: **B42D 15/00**

(21) International Application Number:
PCT/IB2002/002914

(22) International Filing Date: 25 July 2002 (25.07.2002)

(25) Filing Language: English

(26) Publication Language: English

(71) Applicant (for all designated States except US): **ORELL FÜSSLI SICHERHEITSDRUCK AG** [CH/CH]; Dietzingerstrasse 3, CH-8036 Zürich (CH).

(72) Inventors; and

(75) Inventors/Applicants (for US only): **VON FELLENBURG, Ian, Daniel** [CH/DE]; Schaffhauserstrasse 15, 79801 Günzgen (DE). **SCHERTENLEIB, Beat, Roland** [CH/CH]; Schönenbergstrasse 88, CH-8820 Wädenswil (CH).

(74) Agent: **E. BLUM & CO.**; Vorderberg 11, CH-8004 Zurich (CH).

(81) Designated States (*national*): AE, AG, AL, AM, AT, AU, AZ, BA, BB, BG, BR, BY, BZ, CA, CH, CN, CO, CR, CU, CZ, DE, DK, DM, DZ, EC, EE, ES, FI, GB, GD, GE, GH, GM, HR, HU, ID, IL, IN, IS, JP, KE, KG, KP, KR, KZ, LC, LK, LR, LS, LT, LU, LV, MA, MD, MG, MK, MN, MW, MX, MZ, NO, NZ, OM, PH, PL, PT, RO, RU, SD, SE, SG, SI, SK, SL, TJ, TM, TN, TR, TT, TZ, UA, UG, US, UZ, VN, YU, ZA, ZM, ZW.

(84) Designated States (*regional*): ARIPO patent (GH, GM, KE, LS, MW, MZ, SD, SL, SZ, TZ, UG, ZM, ZW), Eurasian patent (AM, AZ, BY, KG, KZ, MD, RU, TJ, TM), European patent (AT, BE, BG, CH, CY, CZ, DE, DK, EE, ES, FI, FR, GB, GR, IE, IT, LU, MC, NL, PT, SE, SK, TR), OAPI patent (BF, BJ, CF, CG, CI, CM, GA, GN, GQ, GW, ML, MR, NE, SN, TD, TG).

Published:
— with international search report

For two-letter codes and other abbreviations, refer to the "Guidance Notes on Codes and Abbreviations" appearing at the beginning of each regular issue of the PCT Gazette.

(54) Title: SECURITY DOCUMENT AND VERIFICATION METHOD

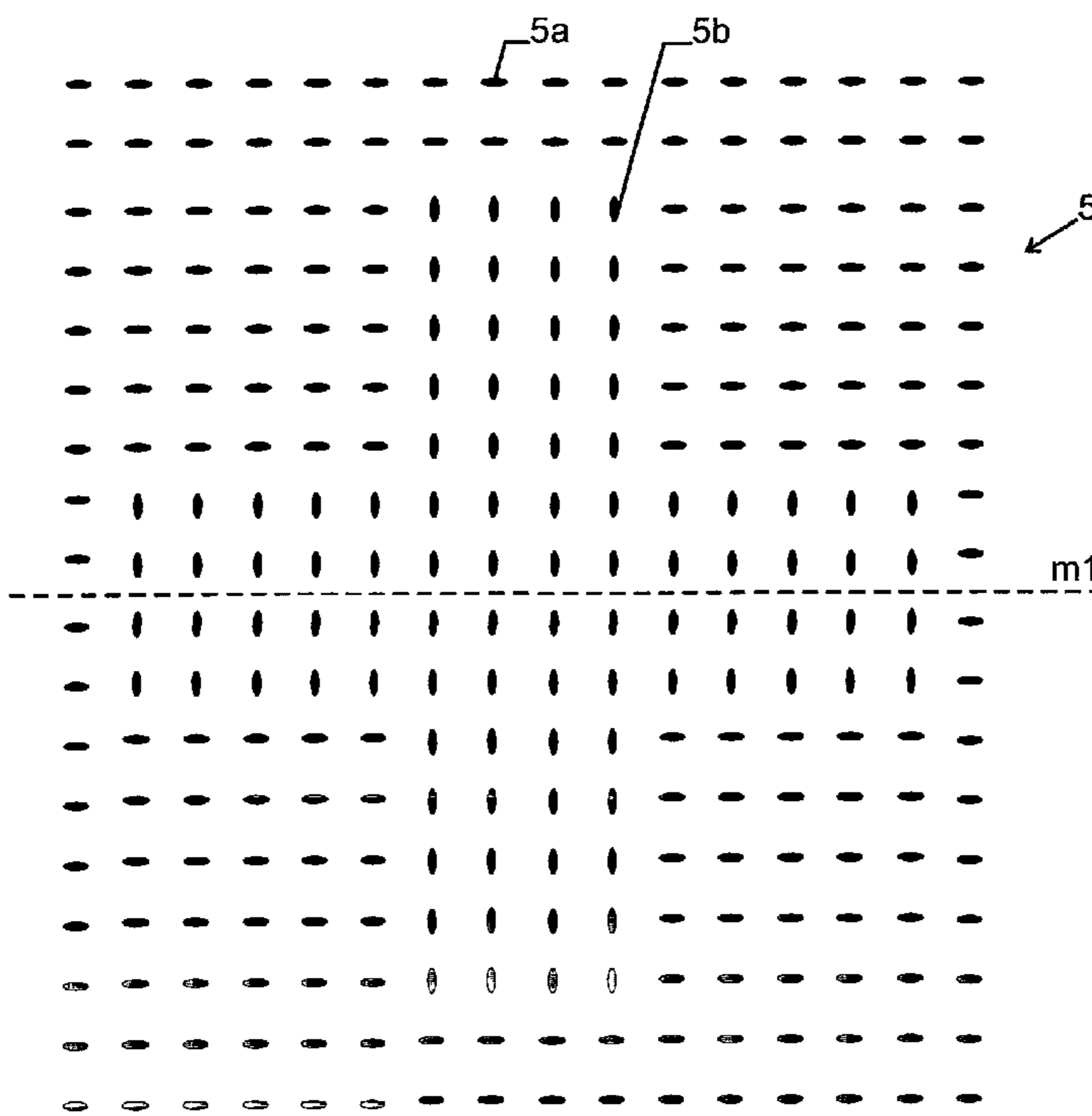

(57) Abstract: A security document, such as a banknote or a cheque, is provided with a perforation pattern (5) having holes (5a, 5b) with elongate cross section. When viewing the perforation pattern (5) from a direction that is non-perpendicular to the surface of the document, different holes will have different optical transmission, which can be verified by eye or electronically. Perforation patterns (5) of this type are hard to forge and easy to verify.

WO 2004/011274 A1

Security document and verification method

Technical Field

5

The invention relates to a method for verifying the authenticity of a security document as well as to a security document having perforations of elongate cross section.

10

Background Art

Fine perforations have been used successfully as a security feature for security documents, i.e. for documents the authenticity of which can be verified in a reasonably reliable manner, such as bank notes, passports or parts thereof, checks, etc.

WO 97/18092 describes a security document having a pattern of fine perforations that are visible when viewed in transmission while they are invisible when viewed in reflection. Even though this feature has found to be a very reliable means for authenticating the document, it is desired to increase the uniqueness of these and similar perforations in order to provide an even higher degree of recognizability and reliability.

WO 00/43216 teaches, inter alia, to add perforations that extend obliquely through the document and that must be viewed under a given angle. However, manufacturing such oblique perforations is difficult and their quality is likely to degrade over time, in particular when used for paper or thin plastic sheet documents that are subjected to frequent mechanical stress, such as bank notes.

35

Disclosure of the Invention

Hence, it is an object of the present invention to provide a method and a document of the type men-

tioned above that further increases the reliability of this type of a security feature based on perforations.

This object is met by the method and document according to the independent claims.

5 The invention uses an effect that is observed with perforations having an elongate cross section. When such perforations are viewed from a direction that is non-perpendicular to the surface of the document, the transmission characteristics depend on the orientation of
10 the viewing direction in respect to the directions of smallest and largest diameter of the cross section of the perforations. Hence, viewing the document from an direction as described above allows to determine the authenticity of the documents from the observed optical trans-
15 mission of the perforations, e.g. by comparing the observed optical transmission to an expected optical transmission and rejecting the document as invalid if there is no match.

 When viewing a perforation from a direction
20 that is perpendicular to its minimum diameter, large transmission can be observed even if the angle between the viewing direction and the direction perpendicular to the document becomes large. On the other hand, when view-
25 ing a perforation from a direction that is perpendicular to its maximum diameter, the transmission is smaller. Hence, both these viewing directions are preferred viewing directions for a verification. Preferably, both viewing directions are used.

 If the document comprises several perfora-
30 tions with different cross sections, a single view along the viewing direction allows to observe differently oriented perforations with different expected optical transmission values, which further increases the reliability of the verification.

35 For obtaining very strong visual effects, the minimum diameter of the elongate perforations should sub-

stantially be equal to or smaller than the thickness of the document carrier.

In one aspect, the invention provides a security document comprising carrier and a security feature with a plurality of perforations in said carrier, wherein:

a first part of the perforations have an elongate cross section with a minimum and a maximum diameter; and

a second part of said perforations have circular cross section; and

the perforations of said first part and of said second part have equal area of cross section and therefore uniform transmission when being viewed from a viewing direction perpendicular a surface of said carrier.

In one aspect, the invention provides a security document comprising carrier and a security feature with a plurality of perforations in said carrier, wherein:

a first part of the perforations have an elongate cross section with a minimum and a maximum diameter; and

a second part of said perforations have circular cross section;

the perforations of said first part and of said second part have equal area of cross section and therefore uniform transmission when being viewed from a viewing direction perpendicular a surface of said carrier;

said perforations extend through said document in a direction perpendicular to a surface of the carrier.

Brief Description of the Drawings

The invention will be better understood and objects other than those set forth above will become apparent when consideration is given to the following detailed description thereof. Such description makes reference to the annexed drawings, wherein:

Fig. 1 shows a bank note having a security perforation pattern,

Fig. 2 shows the security perforation pattern in close view,

3a

Fig. 3 shows a detail of the perforation pattern of Fig. 2,

Fig. 4 is a sectional view of the perforations of Fig. 3,

5 Fig. 5 is a detail of a second possible perforation pattern, and

Fig. 6 is a detail of a third perforation pattern.

10 Modes for Carrying Out the Invention

Fig. 1 shows a bank note having a carrier 1 of paper or plastic with conventional graphical and textual elements 2, 3, 4 and a security perforation pattern 5.

15 As shown in Fig. 2, security perforation pattern 5 comprises a plurality of perforations (holes) 5a, 5b extending through carrier 1. The perforations are arranged in a two-dimensional array. Preferably, they extend through the whole of carrier 1, but they may also

20

extend only partially therethrough as long as the optical transmission when viewed from a viewing direction perpendicular to the surface of carrier 1 is much larger at a perforation than at unperforated locations.

5 As can be seen from Fig. 2, which is a close-up of perforation pattern 5, two different types of holes are used.

A hole 5a and 5b, respectively, of each perforation type is shown in Fig. 3. In the shown embodi-
10 ment, each hole 5a, 5b has elongate cross section and extends through carrier 1 in a direction perpendicular to the surface 1a of the same. The cross section is preferably substantially uniform through the carrier.

The cross sections of holes 5a and 5b in the
15 embodiment of Figs. 3 and 4 are of equal elongate shape, but rotated in respect to each other by an angle of 90° . Each hole is of roughly ellipsoidal cross section having a minimum diameter d_1 and d_1' and a maximum diameter d_2 and d_2' , respectively. The minimum diameter d_1 of hole 5a
20 is substantially parallel to the maximum diameter d_2' of hole 5b and vice versa.

The minimum diameter d_1 and d_1' , respectively, is preferably smaller or approximately equal to the thickness D of carrier 1 and may be in the range of
25 50μ to $300 \mu\text{m}$ for a bank note, preferably not more than $150 \mu\text{m}$. The maximum diameter may be substantially larger, e.g. at least 1.5 times larger than the minimum diameter.

The areas of the cross sections of the holes 5a, 5b are preferably equal. In that case, when the docu-
30 ment is viewed against a light source in optical transmission from a viewing direction 7 that is perpendicular to surface 1a of carrier 1, the transmission of both types of holes is the same and the holes appear equally bright. However, when viewing from a viewing direction 7'
35 that is not perpendicular to surface 1a, the amount light transmitted through the different types of holes 5a, 5b will generally be different because part of the light

will be blocked by the walls of the holes. For example, when viewing the document from direction 7' of Fig. 4, around 50% of the maximum amount of light will be transmitted through hole 5a while hole 5b will appear to be
5 substantially blocked.

Generally, a high transmission will be observed when viewing the perforation pattern along a viewing direction that is perpendicular to the direction m1 of minimum diameter d1 while a low transmission will be
10 observed if the viewing direction is perpendicular to the direction m2 of maximum diameter d2.

This effect can be used for verifying the authenticity of the document by viewing it from at least one viewing direction that is non-perpendicular to surface 1a. The observed optical transmission of the perforations can e.g. be compared to an expected optical
15 transmission from this viewing direction.

To simplify visual verification, it is preferred to provide carrier 1 with two types of perforations having differing cross sections, as shown in e.g.
20 in Figs. 3, 5 or 6. When the document is viewed from a direction non-perpendicular to surface 1a, the perforations of the two groups will generally have differing optical transmission, which allows to check the feature by
25 visually comparing the transmissions.

For example, when viewing perforation pattern 5 of Fig. 2 from a viewing direction perpendicular to direction m1 and non-perpendicular to surface 1a, the perforations within the cross will generally be better visible
30 than those outside it.

In the embodiment of Figs. 3 and 4, the two types of holes 5a, 5b have cross sections that are mutually rotated by 90°. In another embodiment, the holes have cross sections of different shape. Preferably, however, the areas of the cross sections of the different
35 types of points are substantially equal such that the perforations have substantially uniform optical transmis-

sion when viewed along a viewing direction perpendicular to surface 1a. an example of two holes of such a perforation is shown in Fig. 5.

It is also possible to use a perforation pattern having more than two types of points with different cross sections for obtaining even more elaborate effects when viewing the document under an angle.

If the perforation pattern is to be inspected by a human, it is preferred to arrange the types of holes to form a human-recognizable pattern, such as the cross of Fig. 2.

The perforations of perforation pattern 5 are preferably manufactured by laser pulses. For producing a hole with elongate cross section, the beam from the laser can either be moved while applying the pulse or several separate pulses may be applied side by side in spatially overlapping manner.

The production of the perforation pattern is easiest when the dimension of all points is only varied in a single direction because this allows to use a single beam deflector to be operated during hole generation. This leads to a pattern where the minimum diameters of all holes are equal and parallel to each other.

A corresponding embodiment with elongate holes and circular holes is shown in Fig. 6. The first type of holes 5a has a minimum diameter d_1 that is equal to both diameters d_1' of the second type of holes 5b.

Preparing a small perforation pattern as described above by purely mechanical means is, at best, difficult. In order to avoid ridges, drilling techniques would have to be used - it is, however, highly difficult to prepare an elongate hole of the type shown here by means of a mechanical drill. Therefore, using elongate holes makes the perforation pattern more difficult to forge using mechanical production techniques.

Furthermore, mechanically manufactured perforations have rougher edges and therefore increased light

scattering as compared to perforations generated by laser light.

In order to make a mechanical reproduction of the perforation pattern difficult, the minimum diameter
5 d_1, d_1' of the holes should preferably be 150 μm or less.

In the embodiment shown here, the perforation pattern 5 was used in a banknote, but it may be used in other similar applications, such as in cheques or in the pages of a passport or other document that should be hard
10 to forge. Carrier 1 is preferably paper or a flexible plastic.

While there are shown and described presently preferred embodiments of the invention, it is to be distinctly understood that the invention is not limited
15 thereto but may be otherwise variously embodied and practiced within the scope of the following claims.

The embodiments of the invention in which an exclusive property or privilege is claimed are defined as follows:

1. A security document comprising carrier and a security feature with a plurality of perforations in said carrier, wherein:

a first part of the perforations have an elongate cross section with a minimum and a maximum diameter; and

a second part of said perforations have circular cross section;

the perforations of said first part and of said second part have equal area of cross section and therefore uniform transmission when being viewed from a viewing direction perpendicular a surface of said carrier;

said perforations extend through said document in a direction perpendicular to a surface of the carrier.

2. The security document of claim 1, wherein said perforations form a human recognizable transmission pattern when viewed under an angle that is non-perpendicular to a surface of the carrier.

3. The security document of claim 1 or 2, wherein each perforation has substantially uniform cross section through said document.

4. The security document of any one of claims 1 to 3, wherein the carrier is of flexible plastic or paper.

5. The security document of claim 4, wherein the security document is a banknote or part of a passport.

6. The security document of any one of claims 1 to 5, wherein said perforations are arranged in a two-dimensional array.

7. The security document of any one of claims 1 to 6, wherein the minimum diameter is substantially equal to or smaller than a thickness of the carrier.

8. The security document of any one of claims 1 to 7, wherein the maximum diameter is at least 1.5 times larger than the minimum diameter.

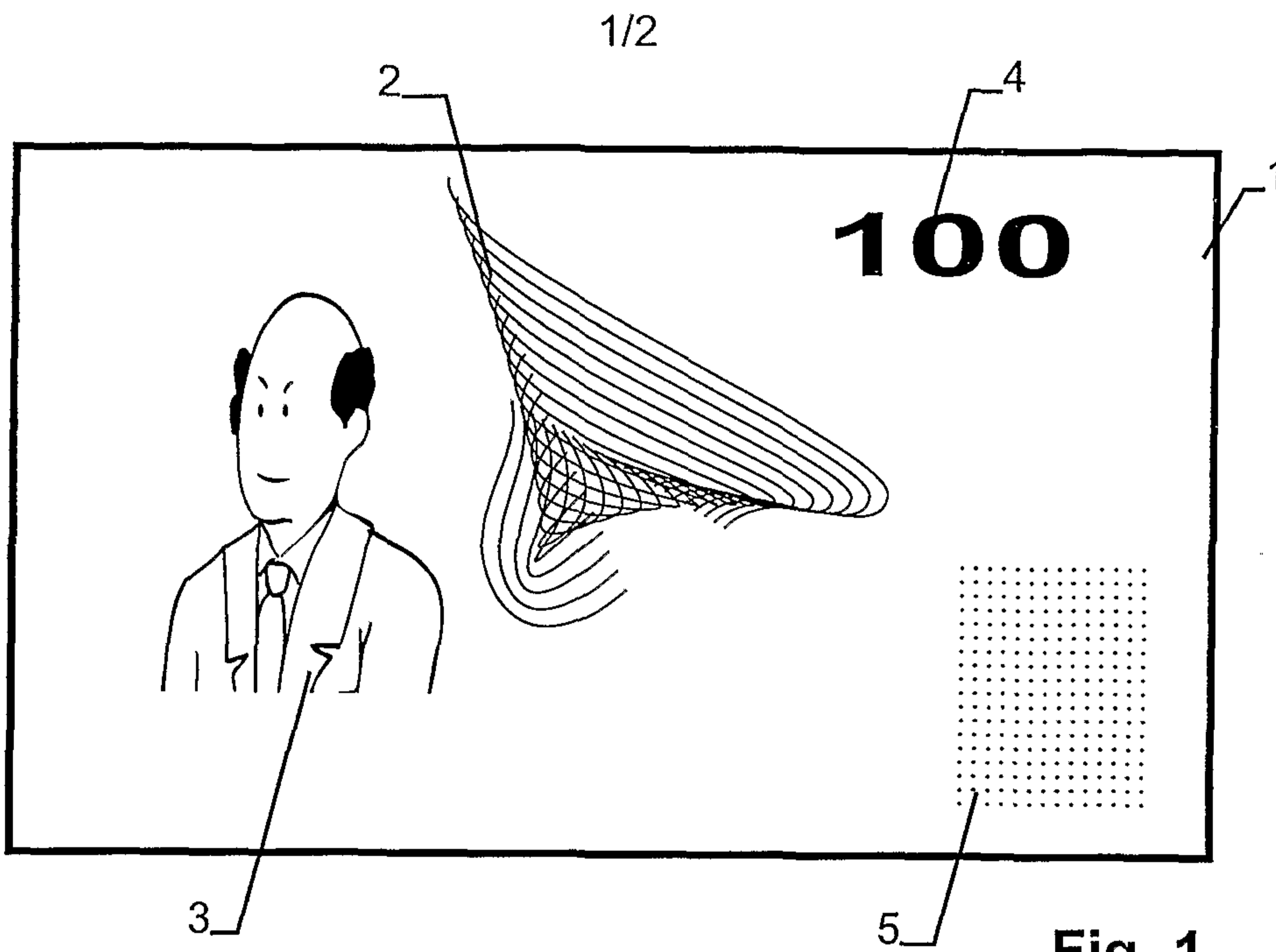

Fig. 1

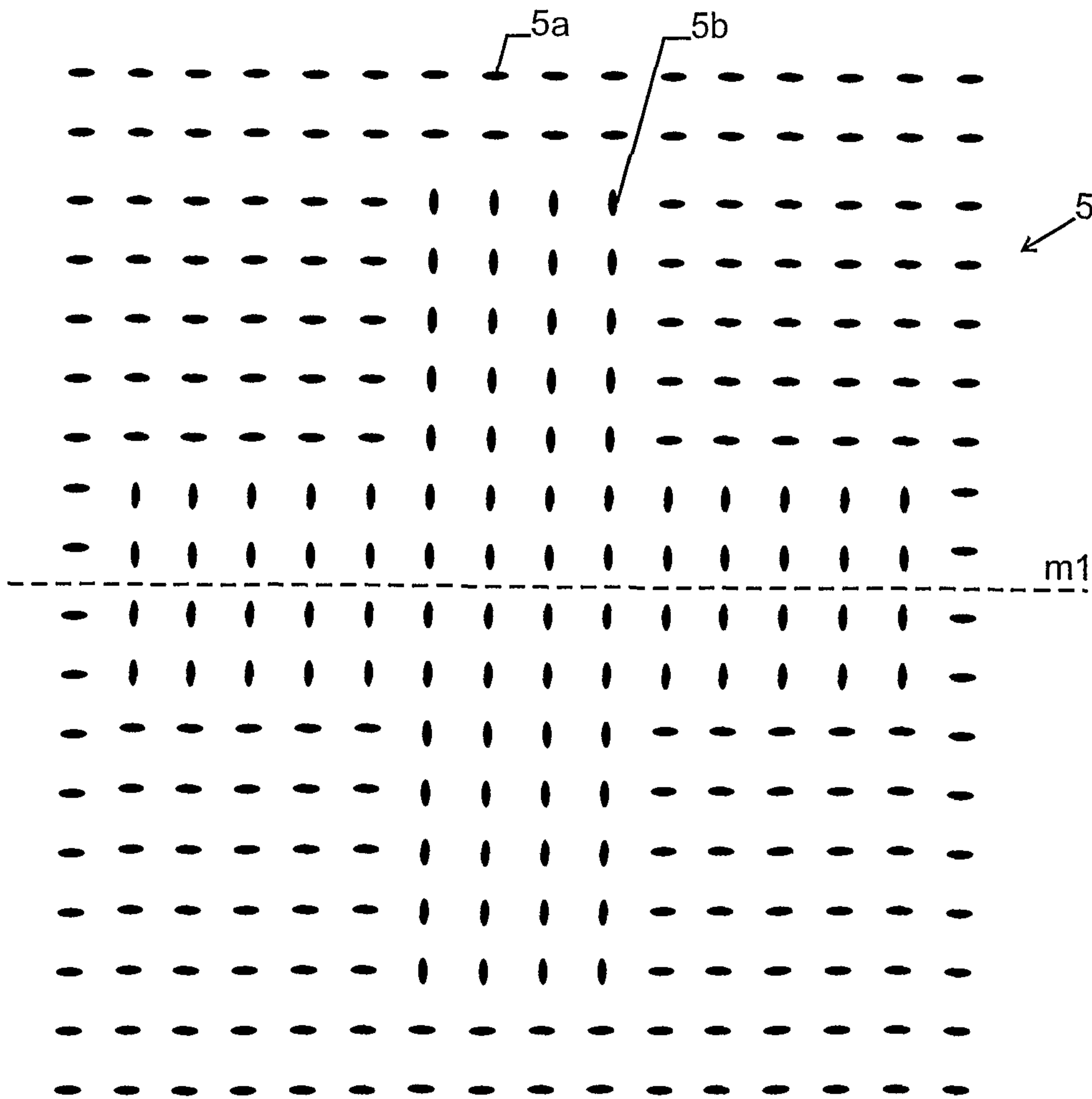

Fig. 2

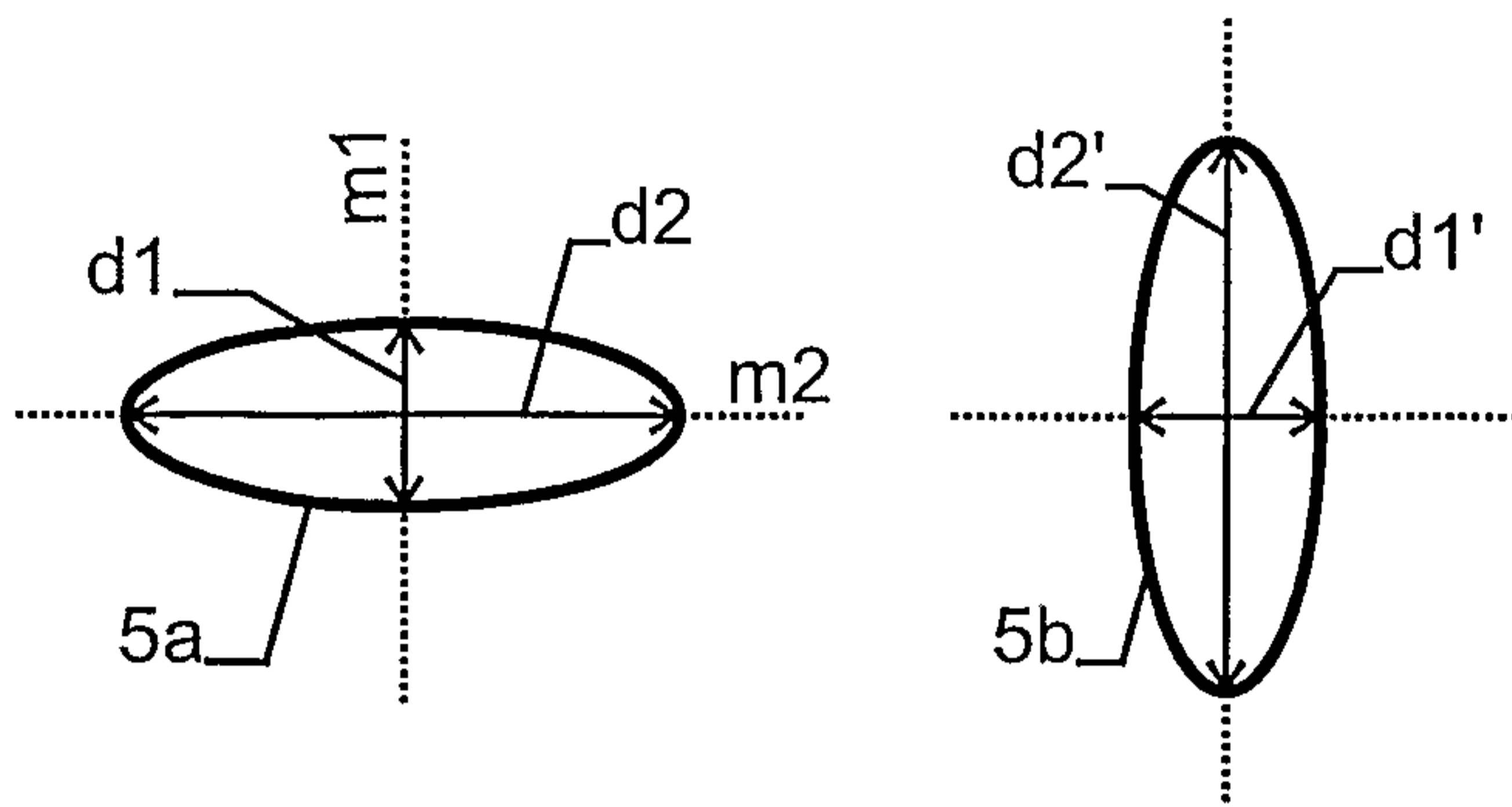

Fig. 3

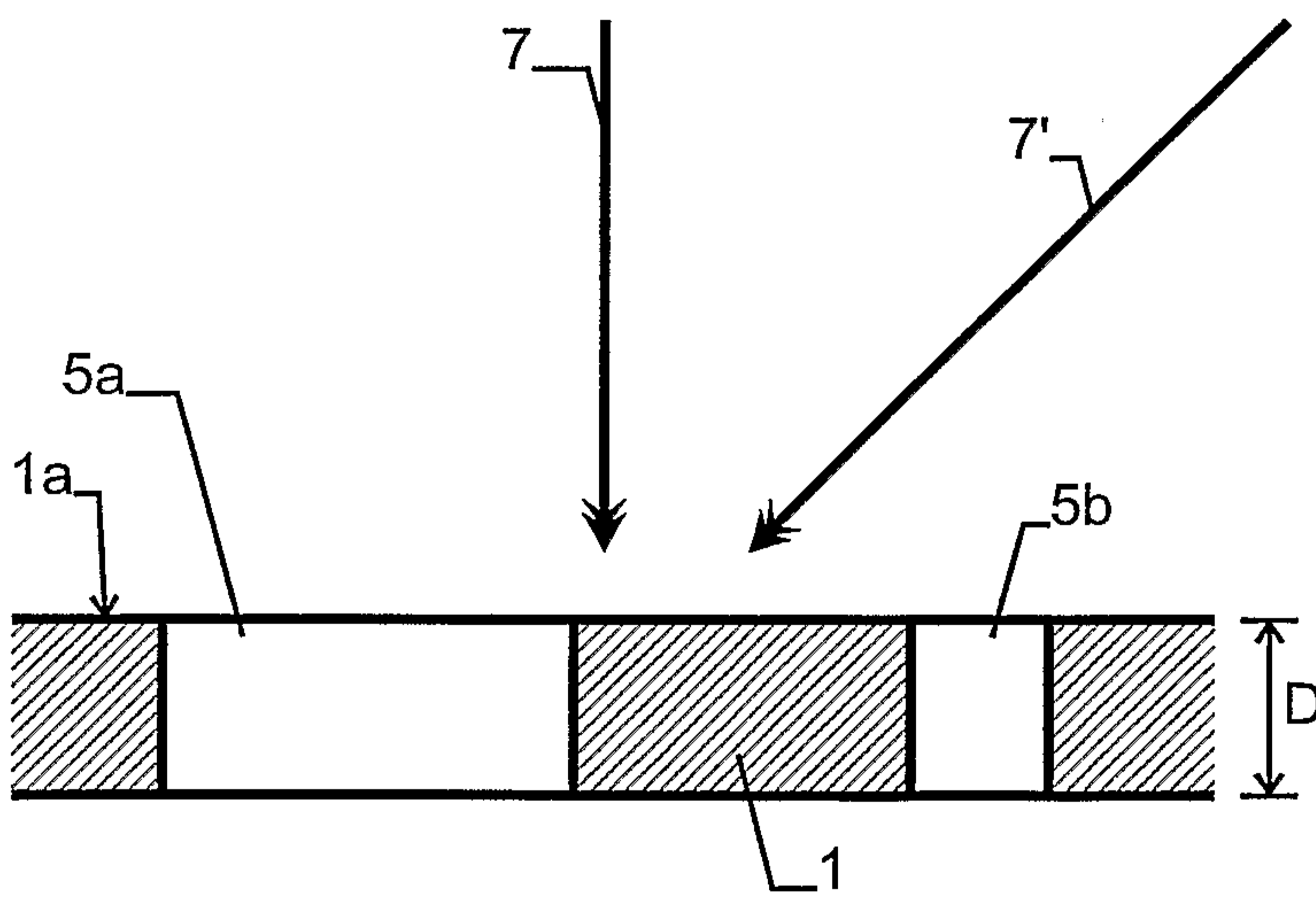

Fig. 4

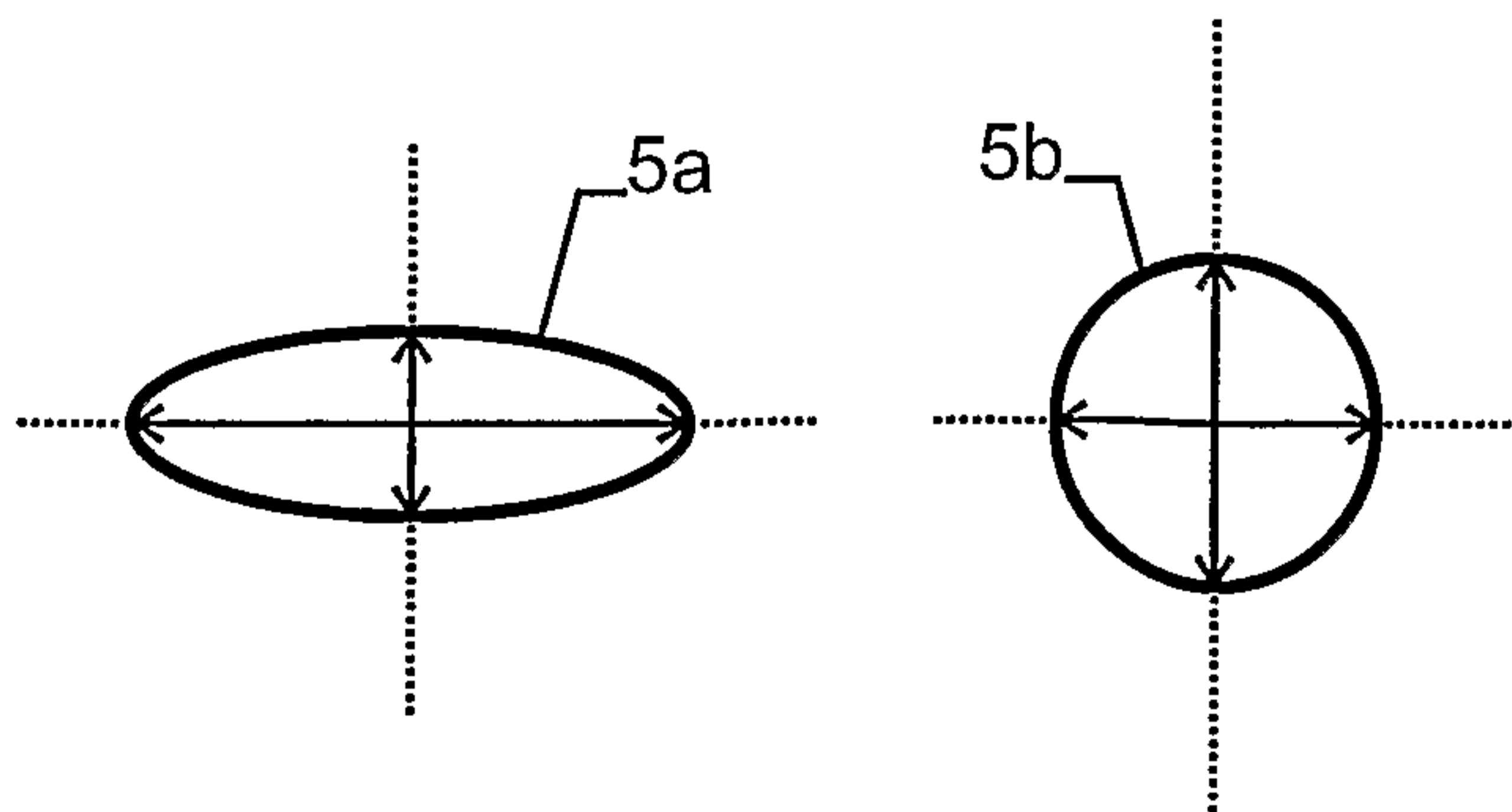

Fig. 5

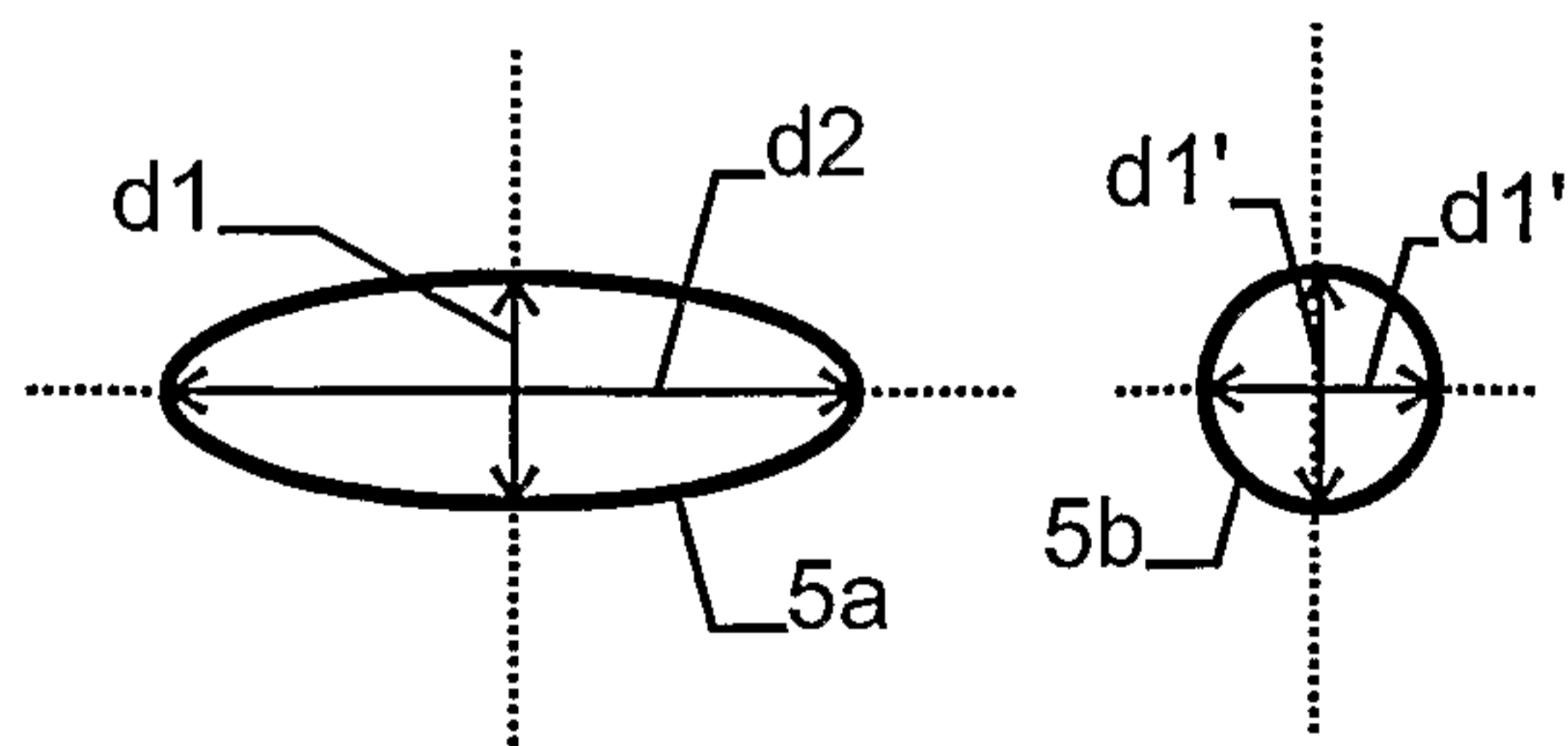

Fig. 6

