

(19) World Intellectual Property Organization  
International Bureau



(43) International Publication Date  
12 June 2008 (12.06.2008)

PCT

(10) International Publication Number  
**WO 2008/068744 A1**

- (51) International Patent Classification:  
*E06B 5/10* (2006.01)
- (21) International Application Number:  
PCT/IL2007/001482
- (22) International Filing Date:  
29 November 2007 (29.11.2007)
- (25) Filing Language:  
English
- (26) Publication Language:  
English
- (30) Priority Data:  
60/872,768      5 December 2006 (05.12.2006)      US

AT, AU, AZ, BA, BB, BG, BH, BR, BW, BY, BZ, CA, CH, CN, CO, CR, CU, CZ, DE, DK, DM, DO, DZ, EC, EE, EG, ES, FI, GB, GD, GE, GH, GM, GT, HN, HR, HU, ID, IL, IN, IS, JP, KE, KG, KM, KN, KP, KR, KZ, LA, LC, LK, LR, LS, LT, LU, LY, MA, MD, ME, MG, MK, MN, MW, MX, MY, MZ, NA, NG, NI, NO, NZ, OM, PG, PH, PL, PT, RO, RS, RU, SC, SD, SE, SG, SK, SL, SM, SV, SY, TJ, TM, TN, TR, TT, TZ, UA, UG, US, UZ, VC, VN, ZA, ZM, ZW.

(71) Applicant (for all designated States except US): **ORAN SAFETY GLASS LTD** [IL/IL]; D.N. Harei Yehuda, 90870 Kibbutz Palmach zova (IL).

(84) Designated States (unless otherwise indicated, for every kind of regional protection available): ARIPO (BW, GH, GM, KE, LS, MW, MZ, NA, SD, SL, SZ, TZ, UG, ZM, ZW), Eurasian (AM, AZ, BY, KG, KZ, MD, RU, TJ, TM), European (AT, BE, BG, CH, CY, CZ, DE, DK, EE, ES, FI, FR, GB, GR, HU, IE, IS, IT, LT, LU, LV, MC, MT, NL, PL, PT, RO, SE, SI, SK, TR), OAPI (BF, BJ, CF, CG, CI, CM, GA, GN, GQ, GW, ML, MR, NE, SN, TD, TG).

(72) Inventor; and  
(75) Inventor/Applicant (for US only): **BAR, Zvika** [IL/IL]; D.N. Harei Yehuda, 90870 Kibbutz Palmach zova (IL).

**Declaration under Rule 4.17:**  
— of inventorship (Rule 4.17(iv))

(74) Agent: **DR. SARAH PRESENTI & CO. LAW OFFICES**; 96 Yigal Alon Street, Tel Aviv 67981 (IL).

**Published:**  
— with international search report  
— before the expiration of the time limit for amending the claims and to be republished in the event of receipt of amendments

(81) Designated States (unless otherwise indicated, for every kind of national protection available): AE, AG, AL, AM,

(54) Title: **BLAST AND IMPACT RESISTANT WINDOW PANE SYSTEMS**

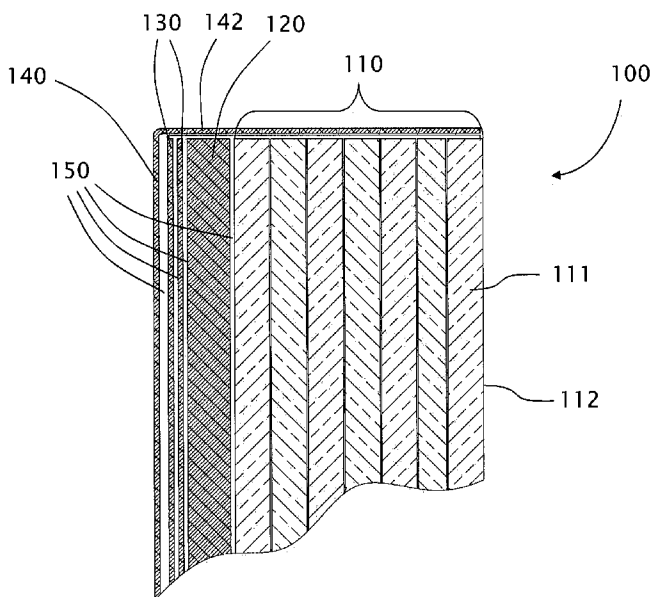

(57) Abstract: Window pane systems which offer improved protection against blast and impact hazards, including contact blast caused by a bomb or a shell, with or without hollow charge and bullets. A window pane system of the present invention includes multiple glass layers, to absorb the ballistic impact of the explosion; a thick polymer such as polycarbonate, to absorb the kinetic energy of the blast including contact blast; and multiple elastic thin layers of polymer such as polycarbonate, to absorb the blast impact such as the shock wave and shrapnel. Optionally, the last layer is extended such that the last layer is covering up to the full width of the window pane system, preferably in all four sides of the window pane system.

WO 2008/068744 A1

## BLAST AND IMPACT RESISTANT WINDOW PANE SYSTEMS

### FIELD OF THE INVENTION

[Para 1] The present invention is generally in the field of resistant window pane systems, and more particularly the present invention is related to window pane systems which offer improved protection against blast and impact hazards, including contact blast caused by a bomb or a shell, with or without hollow charge and bullets.

### BACKGROUND OF THE INVENTION AND PRIOR ART

[Para 2] When an explosive device detonates, high pressure and high temperature are created. In the chemical reaction, compounds break down to form various gases. The concentrated gases are under very high pressure and thus, they expand rapidly. The heat speeds up the individual gas particles, boosting the pressure even higher. In a high explosive, the gas pressure is strong enough to destroy structures and injure and kill people. If the gas expands at a rate faster than the speed of sound, the fast expanding gas generates a powerful shock wave that causes the crashing of encountered objects. The pressure can also push pieces of solid material outward at great speed, causing them to hit people or structures with immense force.

[Para 3] The unique burning of explosives creates a sonic wave which velocity depends on the material in which the sonic wave is moving: the material density, elasticity and temperature. The magnitude of the sonic wave is not

constant but decays at rate relative to  $L^3$ , where  $L$  is the distance from the place of detonation, given by the equation:

$$E_b = \frac{K_b * 1}{L^3}$$

where  $E$  is the energy of the detonation after the explosion,  $b$  denotes the type of explosive,  $K$  is the explosion constant (for TNT, for example,  $K=1$ ). The blast impact also depends on the shape of the explosive device. For example: a square explosive device creates a different wave than a conic explosive device or a bullet-like explosive device.

[Para 4] A variety of windows offer blast resistance and impact resistance solutions, most of which typically offer a single type of protection, namely bullet proof, blast resistant or impact resistant. But prior art blast resistant windows cannot withstand the detonation of an explosive device while in contact with the exterior pane of the window. Prior art blast resistant windows may withstand an explosion event that take place several meters away from the window and even tens and hundreds of meters from the window.

[Para 5] U.S. Pat. No. 3,624,238 is concerned with a bullet resistant structure of laminated character comprising outer faces or piles of safety glass with an intermediary ply formed by a polycarbonate and a resin.

[Para 6] U.S. Pat. No. 4,312,903 deals with an impact resistant double glazed structure and is concerned in particular with the thickness of the layers of the laminated window panes, and their chemical compositions. U.S. Pat. No. 6,333,085 discloses fixed double glazing window systems which offer improved

protection against both blast and impact hazards, but will not withstand a contact blast.

[Para 7] Triple glazed windows are also known as described, for example in U.S. Pat. No. 5,553,440. Such windows may also be broken easily. U.S. Pat. No. 6,108,999 offers some improvement providing a window glazing unit which may be bullet-resistant, and which offers the advantages of being shatter-resistant but not blast resistant. U.S. Pat. '999 provides a window 10 illustrated in Figure 1. Window 10 includes two glass sheets 30 and 32, and a shatter-resistant thermoplastic sheet 20 in between glass sheets 30 and 32. A U shaped part 40 supports thermoplastic sheet 20, thus thermoplastic sheet 20 is smaller in size than glass sheets 30 and 32. Being smaller in size further reduces the elasticity effect of thermoplastic sheet 20, which elasticity is not sufficient to absorb the blast impact of a bomb which detonates a few meters away.

[Para 8] There is therefore a need for a window pane system which can offer improved protection against blast and impact hazards, including contact blasts caused by a bomb or a shell, with or without hollow charge and bullets.

[Para 9] Figure 2 illustrates the operational steps of a hollow charge device 60. In step 80 device 60 is in a state before detonation; in step 82 device 60 is in a state just after detonation; in step 84 device 60 is in a state well after detonation, where a liner 99 has started to form; in step 86 device 60 is in a state just after detonation. In step 86, the metal glazing 70 of the inner cone has completely converted into a liner 99 which moves forward at an accelerated

speed. The shape of cone 92, that is the radius and head angle, determine the angle at which the shock wave will move forward.

[Para 10] To eliminate the effect of liner 99, the symmetry of device 60 and more particularly, the symmetry of inner cone 92 must be breached, which is done by slat armor 50 such as metal bars nets and the like (see Figure 3). Slat armors are statistical barriers that are disposed in front of a window to be protected. When device 60 hits the net of slat armor 50 and the dent formed in device 60 cancels the symmetry of device 60 and thereby the effect of liner 99 is eliminated.

#### DEFINITIONS

[Para 11] The terms "blast window" and "blast resistant" refer to the ability of a window pane system to withstand blast caused, for example, by an explosion of a bomb which is in contact with the exterior pane.

[Para 12] The terms "contact blast" and "contact blast resistant", refer to the ability of a window to withstand the impact force applied for example by a bomb or a shell that exploding when being in contact with the exterior pane of the window.

[Para 13] The term "slat armor" is used herein in the context of metal structures such as metal bars nets and the like (see Figure 3). Slat armors are statistical armor barriers that are disposed in front of target to be protected. Figure 4 depicts an army vehicle protected by slat armor 52.

[Para 14] The term "Polycarbonate" is used herein for transparent materials selected from the group consisting of Polyester, Polycarbonate, Acrylic, or any other known in the art.

#### SUMMARY OF THE INVENTION

[Para 15] It is thus the intention of the present invention to overcome prior art deficiencies and provide a window pane system which can offer improved protection against blast and impact hazards, including contact blasts caused by a bomb or a shell or a bullet, the shell or bullet being with or without hollow charge.

[Para 16] An aspect of the present invention is to provide window pane systems including a layer of thick polymer such as polycarbonate, to absorb the kinetic energy of the blast including contact blast.

[Para 17] According to the teachings of the present invention there is provided a window pane system, which includes: a) multiple glass layers, to absorb the ballistic impact of the explosion; b) a thick polymer such as polycarbonate, to absorb the kinetic energy of the blast including contact blast; and c) multiple elastic thin layers of polymer such as polycarbonate, to absorb the blast impact such as the shock wave and shrapnel. Optionally, the last layer is extended such that the last layer is covering up to the full width of the window pane system, preferably in all sides of the window pane system.

[Para 18] The elastic layers are adhered with glue such as polyurethane, which extends the elasticity of the polymer layers.

[Para 19] Optionally, window pane system further includes a gap disposed between the thick layer and the thin layers. The width of the gap is preferably of a size wide enough for the thick layer to move inside the gap and thereby absorb part of the blast impact. The gap is typically filled with gas such as air, which is treated to prevent condensation as in prior art. The positioning of the gap is not limited to be between the thick layer and the thin layers, and in other embodiments of this invention a gap can be disposed between any two adjacent layers.

[Para 20] Optionally, window pane system further includes slat armor in front of the slat armor, to neutralize the hollow charge effect of arriving shells or bullets.

#### BRIEF DESCRIPTION OF THE DRAWINGS

[Para 21] The present invention will become fully understood from the detailed description given herein below and the accompanying drawings, which are given by way of illustration and example only and thus not limitative of the present invention, and wherein:

FIG. 1 shows an example of a prior art window with glass sheets, and a shatter-resistant thermoplastic sheet in between.

FIG. 2 illustrates the operational steps of a prior art hollow charge device.

FIG. 3 illustrates, by way of example, prior art slat armors to a hollow charge device.

FIG. 4 depicts an army vehicle protected by slat armor.

FIG. 5 illustrates a cross-section of a blast resist window pane system according to embodiments of the present invention.

FIG. 6a illustrates a front view of the last thin layer of Polycarbonate of a blast resist window pane system according to embodiments of the present invention.

FIG. 6b illustrates a cross-section of the last thin layer of Polycarbonate of a blast resist window pane system according to embodiments of the present invention.

FIG. 6c illustrates a front and perspective views of a blast resist window pane system according to embodiments of the present invention, the window having a non-rectangular shape.

FIG. 6d illustrates a front and perspective views of a blast resist window pane system according to another embodiment of the present invention, the window having a non-rectangular shape.

FIG. 7a illustrates embodiments of a blast resist window pane system according to the present invention, including a gap of gas between the thick of Polycarbonate and the last thin layer of Polycarbonate.

FIG. 7b illustrates another embodiment of a blast resist window pane system according to the present invention, including a gap of gas and a thick of Polycarbonate and the last thin layer of Polycarbonate between the glass layers.

FIG. 8 illustrates a blast resist window pane system according to embodiments of the present invention including slat armor.

FIG. 9a illustrates a hollow charge device detonating on a steal barrier, having a liner penetration the steal barrier and dispersing at an angle  $\theta_1$ .

FIG. 9b illustrates a hollow charge device detonating on a blast resist window pane system according to embodiments of the present invention, having a liner penetration the widow system and dispersing at an angle  $\theta_2$ .

#### DETAILED DESCRIPTION OF THE PREFERRED EMBODIMENTS

[Para 22] The present invention now will be described more fully hereinafter with reference to the accompanying drawings, in which preferred embodiments of the invention are shown. This invention may, however, be embodied in many different forms and should not be construed as limited to the embodiments set forth herein; rather, these embodiments are provided ,so that this disclosure will be thorough and complete, and will fully convey the scope of the invention to those skilled in the art.

[Para 23] Unless otherwise defined, all technical and scientific terms used herein have the same meaning as commonly understood by one of ordinary skill in the art to which this invention belongs. The methods and examples provided herein are illustrative only and not intended to be limiting.

[Para 24] By way of introduction, the principal intentions of the present invention include providing a window pane system which can offer improved protection against blast and impact hazards, including contact blasts caused by a bomb or a shell or a bullet, the shell or bullet being with or without hollow charge.

[Para 25] Figure 5 illustrates a cross-section of a blast resist window pane system 100 according to embodiments of the present invention. Window pane

system 100 includes layers of glass 110, as in prior art. Layers of glass 110 can be made of a transparent material, the transparent material selected from the group consisting of glass, ceramics, tempered silica glass, or any other known in the art. The transparent material is referred to herein after as "glass". The external surface 112 of the first glass layer 111 is the surface with which the explosive device makes the first contact and detonates. The objective of the layers of glass 110 is, as in prior art blast resist window pane systems, to absorb the ballistic impact of the explosive device and is designed according to the ballistic threat glass 110 is aimed to defend.

[Para 26] The next layer after the layers of glass 110 is a layer 120 of thick elastic and transparent material. The thick transparent material is selected from the group including Polyester, Polycarbonate, Acrylic, or any other transparent material polymers known in the art. The objective of the thick layer of Polycarbonate 120 is to absorb the kinetic energy of the blast impact and is designed according to the magnitude of threat glass 110 is aimed to defend. Thick layer 120 also blocks relatively large shrapnel.

[Para 27] The next layers after the thick layer of Polycarbonate 120 are layers 130 of thin transparent material. The transparent material is selected from the group of materials including Polyester, Polycarbonate, Acrylic, or any other polymers known in the art. The objective of the thin layers of Polycarbonate 130 is to provide blast resist window pane system 100 with elongation, and absorb the blast shock wave is designed according to the magnitude of threat glass 110 is aimed to defend. Thin layers 130 are strong and elastic.

[Para 28] To enhance the elasticity of thin layers 130 the last thin layer 140 is designed such that thin layer 140 has an increased blast absorption capacity. The last thin layer 140 is the most internal layer of blast resist window pane system 100. Figure 6a illustrates a front view and Figure 6b illustrates a cross-section of the last thin layer 140 of Polycarbonate of a blast resist window pane system 100 according to embodiments of the present invention.

[Para 29] Thin layer 140 is has, in the example shown in Figure 6a, preferably four folding parts 142 that are folded to wrap all four sides of blast resist window pane system 100. Note that the window may have any geometrical shape and the folding parts 142 are adapted to the window shape. Figure 6c illustrates a front and perspective views of a blast resist window pane system 200, the window having a trapezoid shape. Figure 6d illustrates a front and perspective views of a blast resist window pane system 300, the window having a non-rectangular shape.

[Para 30] Referring back to FIGs. 5, 6a and 6b, when a contact blast occur at external surface 112, folding parts 142 pull away from parts 142 initial position to extend thin layer 140 elasticity and thereby prevent tearing of thin layer 140 due to the high-speed dynamic Load of the blast. The objective of thin layers 140 is then to absorb the remainder of the blast shock wave and to be spall resist, that is prevent shrapnel from and entering the space beyond blast resist window pane system 100.

[Para 31] Blast resist window pane system 100 has another important advantage: to substantially reduces the effective angle of destructive movement

of a liner 99 (see Figure 2) created by the detonation of a hollow charge 60. Figure 9a illustrates a hollow charge device 60 detonating (step 86) on a steal barrier 500, having a liner 99 penetration the steal barrier 500 and dispersing at an angle  $\theta_1$ . Typically,  $\theta_1$  is about  $90^\circ$  for a typical steal barrier 500. Figure 9b illustrates a hollow charge device 60 detonating (step 86) on a blast resist window pane system 100 according to embodiments of the present invention, having a liner 99 penetration the widow system 100 and dispersing at an angle  $\theta_2$ . Typically,  $\theta_2$  is less that  $65^\circ$  for a blast resist window pane system 100 according to embodiments of the present invention.

[Para 32] All layers are adhered to each other by designated glues 150, the glues 150 selected from the group including P.V.B (Polyvinyl Butyrel), Polyurethane, Acrylic, SentryGlas, Noviflex, E.V.A (Etjylehe Vinyl Acetate), Epoxy and the like. Glue 150 is preferably selected to also increase the overall elasticity of blast resist window pane system 100. Blast resist window pane system 100 may include any number of glass layers and Polycarbonate layers.

[Para 33] In another embodiment of a blast resist window pane system 101, according to the present invention, a gap 160 is set between thick layer 120 and thin layers 130, as illustrated in Figure 7a. The width of gap 160 is preferably of a size wide enough for thick layer 120 to move inside space 160 and thereby absorb part of the blast impact. Gap 160 is typically filled with gas such as air, which is treated to prevent condensation as in prior art. Gap 160 positioning is not limited to the position between thick layer 120 and thin layers 130, and in other embodiments of this invention gap 160 can be disposed between any

adjacent layers. For example, Figure 7b illustrates another embodiment of a blast resist window pane system 102, including a gap 160 of gas and a thick layer of Polycarbonate 120, disposed among the glass layers 110.

[Para 34] In another embodiment of the present invention slat armor 170 is disposed in front of blast resist window pane system 100. Statistically, there are about 80% (and even more) chance that slat armor 170 will dent a hollow charge device 60 before impact, and thus prevent a liner 99 from being created. Figure 8 illustrates a blast resist window pane system 100 according to embodiments of the present invention including slat armor 170. The objective of the section consisting of the multiple glass layers 110 and thick Polycarbonate layer 120 is to absorb the blast energies and the objective of multiple Polycarbonate layers 130 and 140 is to absorb the spall.

[Para 35] The invention being thus described in terms of several embodiments and examples, it will be obvious that the same may be varied in many ways. Such variations are not to be regarded as a departure from the spirit and scope of the invention, and all such modifications as would be obvious to one skilled in the art.

## WHAT IS CLAIMED IS:

1. A window pane system comprising:
  - (a) multiple layers of glass sheet;
  - (b) a thick layer of elastic and transparent material; and
  - (c) one or more thin layer of elastic and transparent material, wherein the last thin layer comprises at least one folding parts that are folded to wrap one or more sides of the window pane system, thereby said last thin layer provides an increased blast absorption capacity.
2. The window pane system of claim 1, wherein the window pan system has sufficient capacity to absorb the impact of a blast, and wherein the window pan system has sufficient capacity to substantially reduce the effective angle of destructive movement of a liner created by the detonation of a hollow charge.
3. The window pane system of claim 1, wherein said elastic and transparent material of said thick layer, is selected from the group of polymers including Polyester, Polycarbonate and Acrylic.
4. The window pane system of claim 1, wherein said elastic and transparent material of each of said thin layers, is selected from the group of polymers including Polyester, Polycarbonate and Acrylic.
5. The window pane system of claim 1, wherein said glass layers have sufficient capacity to absorb the ballistic impact of said blast.

6. The window pane system of claim 1, wherein said thick layer has sufficient capacity to absorb the kinetic energy of said blast including contact blast.
7. The window pane system of claim 1, wherein said thin layers have sufficient capacity to absorb said blast shock wave and shrapnel.
8. The window pane system of claim 1, wherein all of said layers are adhered to each other by designated glues.
9. The window pane system of claim 8, wherein said glues are selected from the group of materials including Polyvinyl Butyrel, Polyurethane, Acrylic, SentryGlas, Noviflex, Etjylehe Vinyl Acetate and Epoxy.
10. The window pane system of claim 8, wherein said glues, increase the overall elasticity of the window pane system.
11. The window pane system of claim 1 further including a gap disposed between two adjacent layers of said layers, wherein said gap is filled with gas, which is treated to prevent condensation.
12. The window pane system of claim 11, wherein said gap disposed between said thick layer and said thin layers, and wherein the width of said gap is preferably of a size wide enough for said thick layer to move inside said gap and absorb part of said blast impact.
13. The window pane system of claim 11, wherein said gas is air.

14. The window pane system of claim 1 further including a slat armor device, wherein said slat armor device is disposed in front the window pane system with respect to the flying path of a hollow charge device.

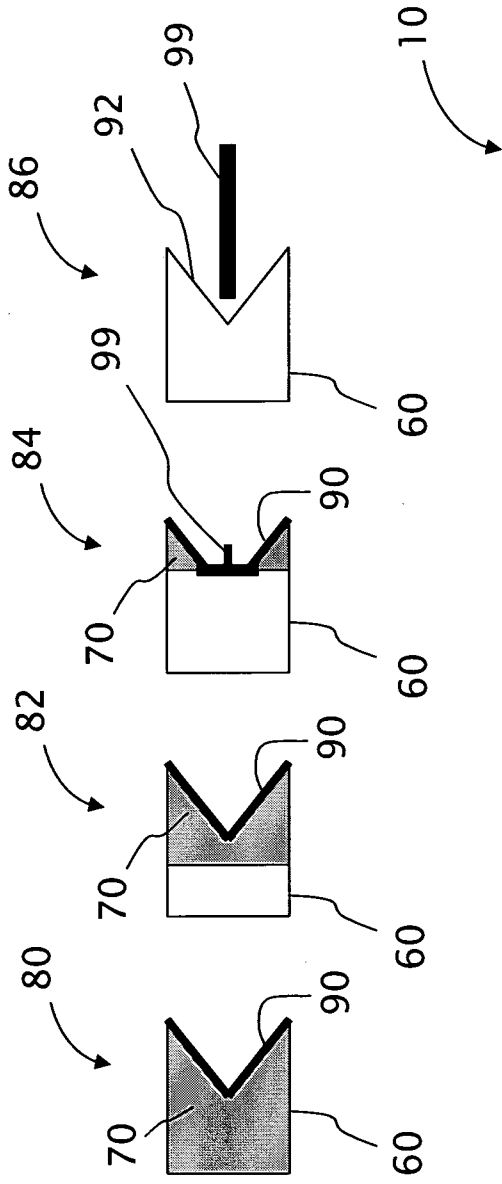

Fig. 2  
PRIOR ART

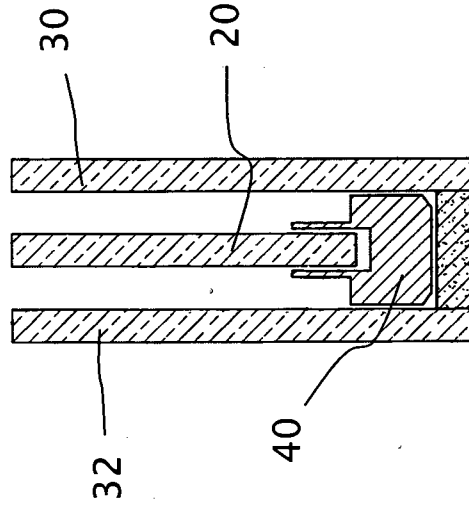

Fig. 1  
PRIOR ART

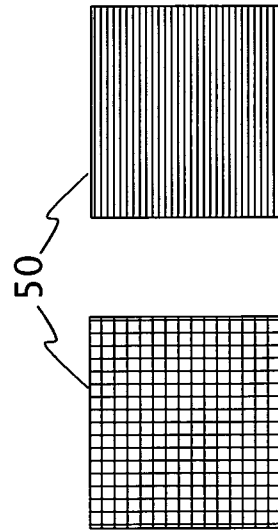
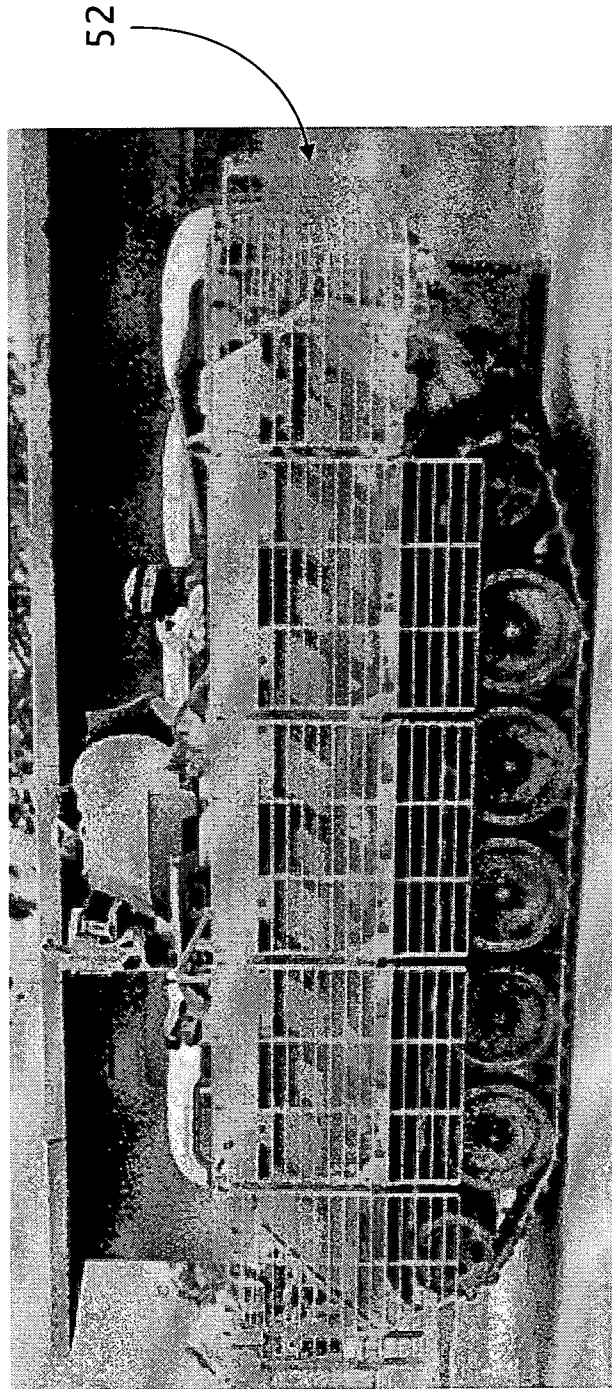

Fig. 3  
PRIOR ART



*Fig. 4*  
PRIOR ART

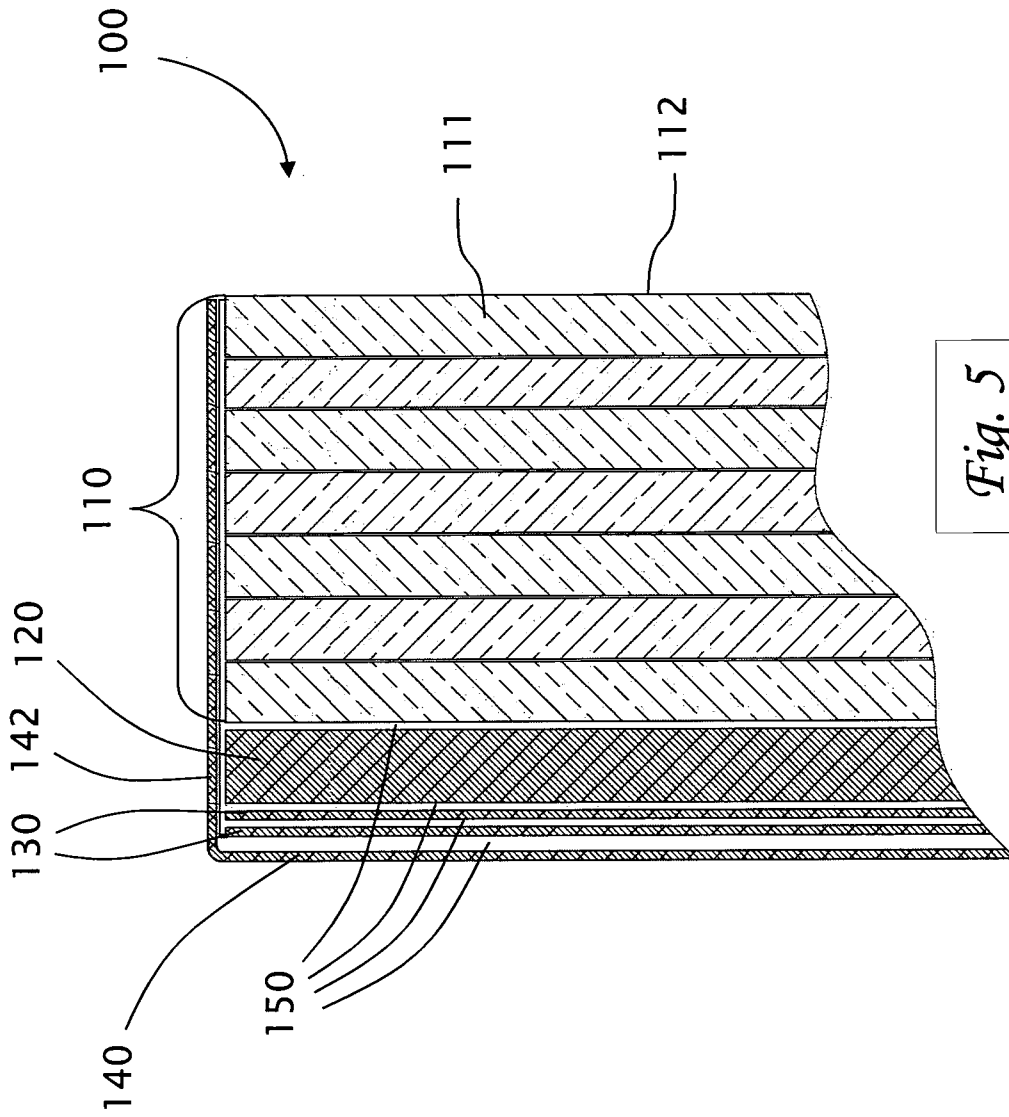

Fig. 5

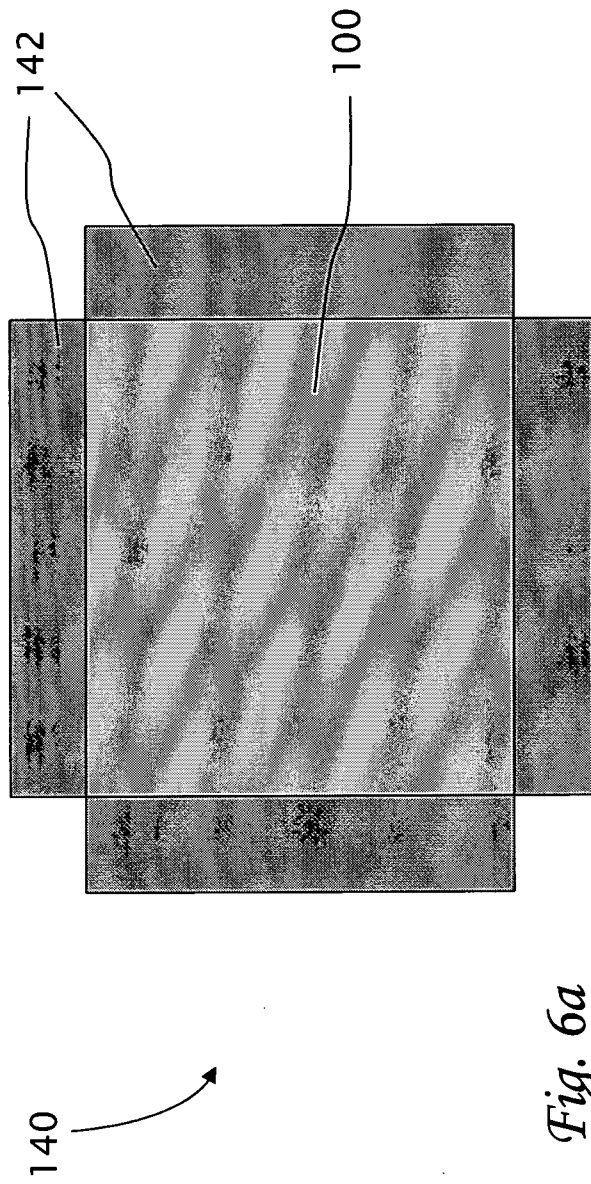

Fig. 6a

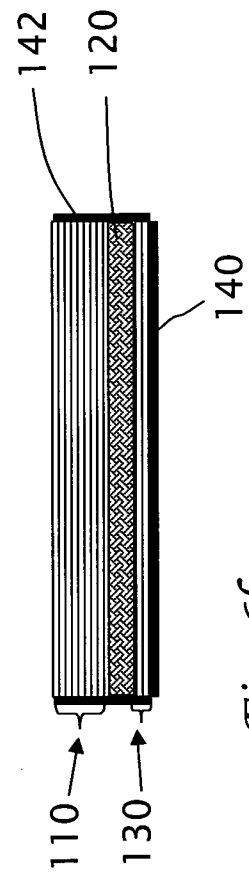
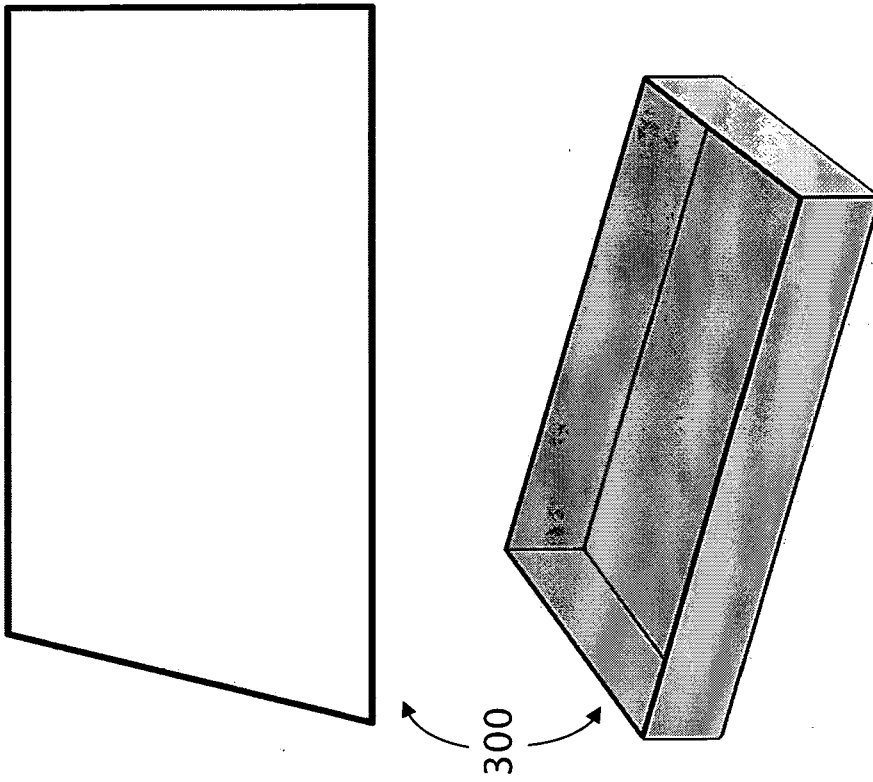
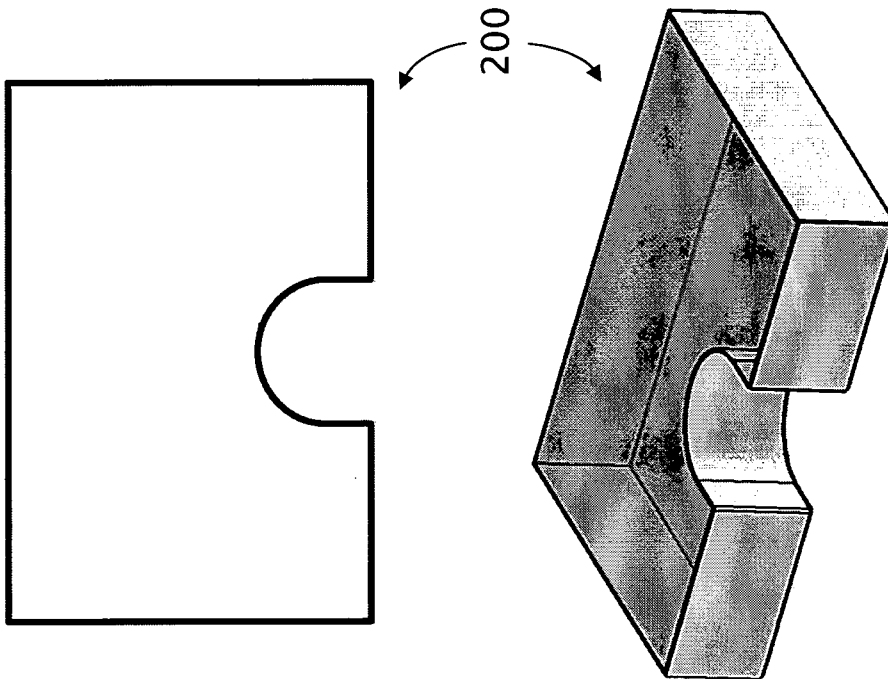

Fig. 6b



*Fig. 6d*



*Fig. 6c*

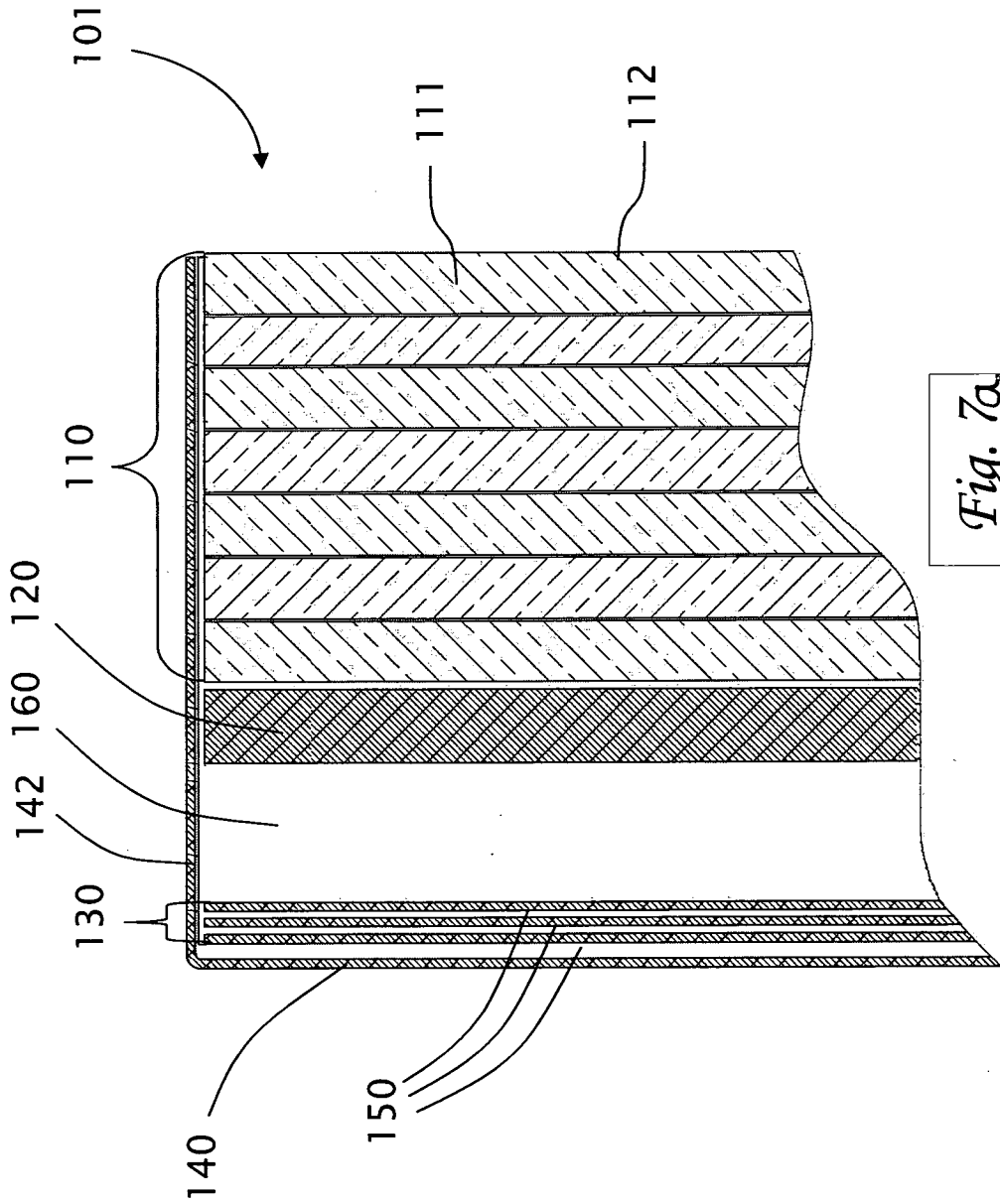

Fig. 7a

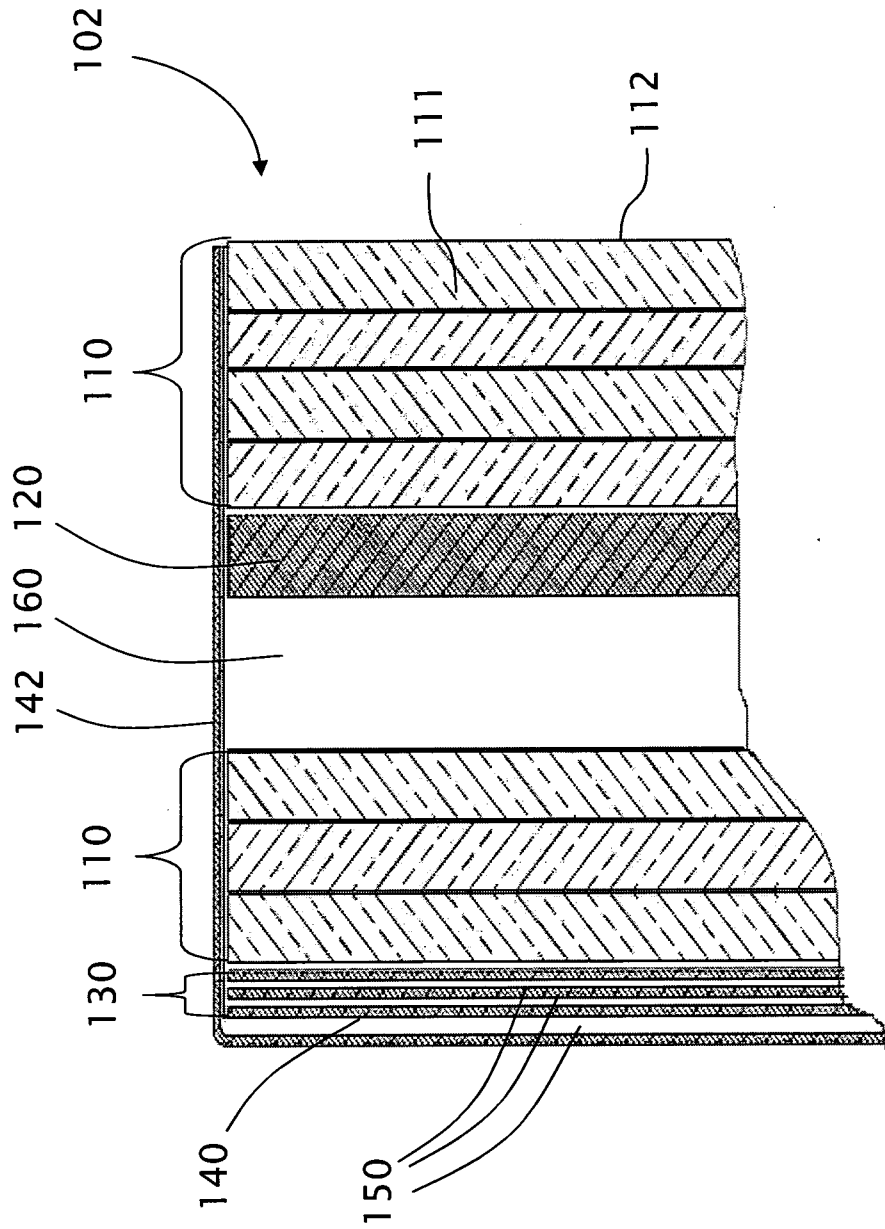
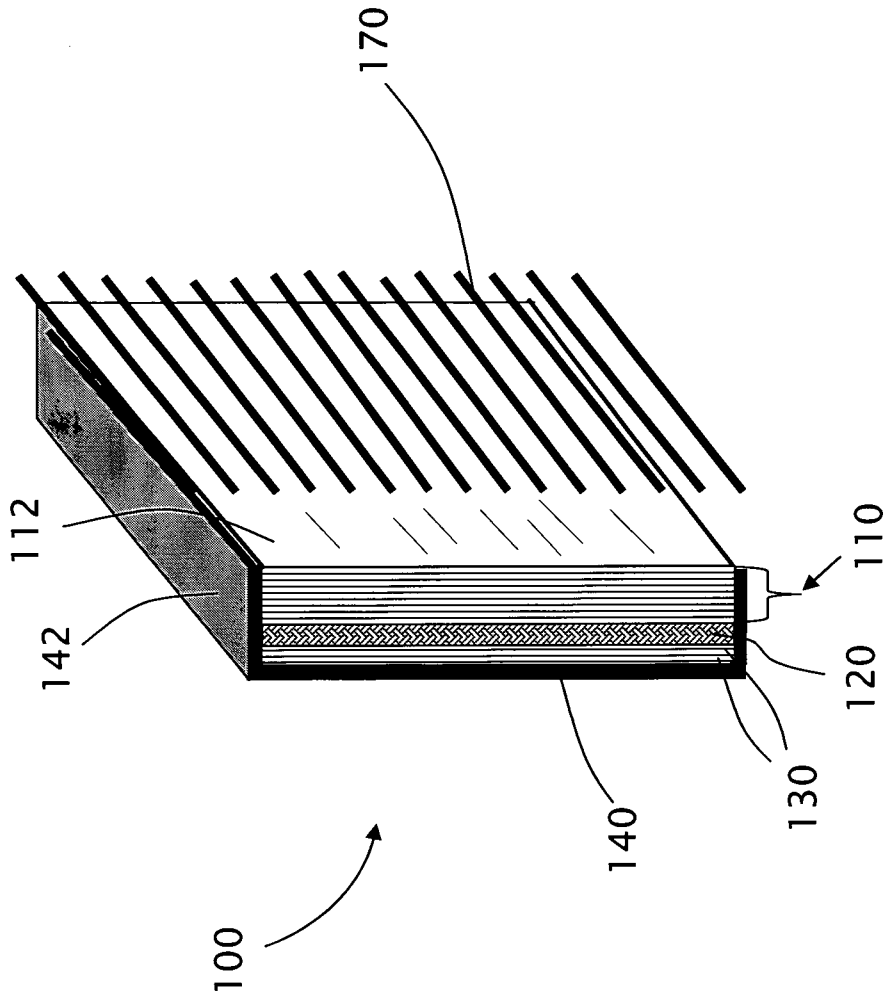

Fig. 7b



*Fig. 8*

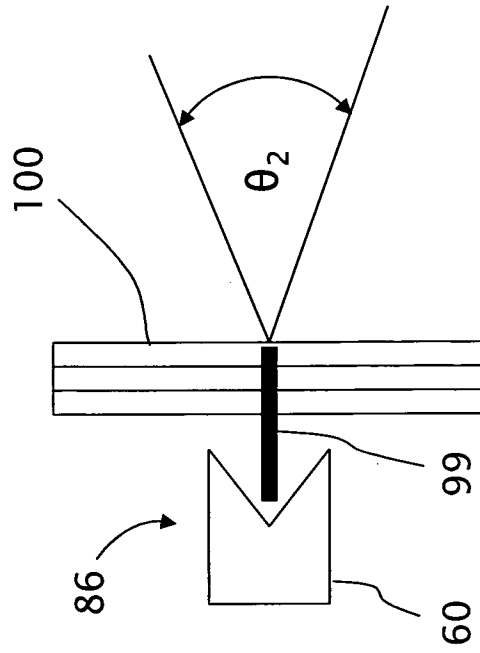
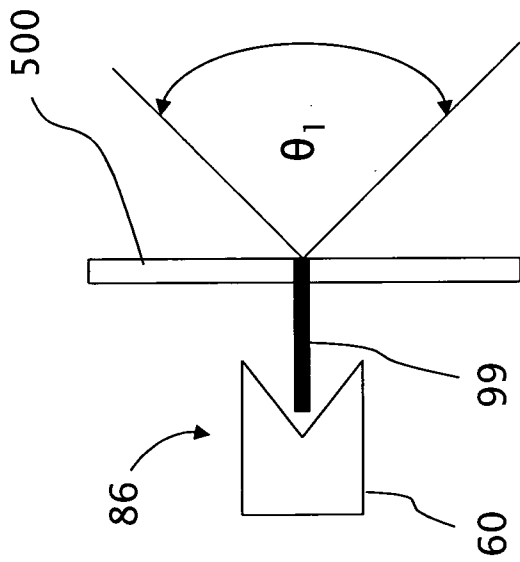

Fig. 96

## INTERNATIONAL SEARCH REPORT

International application No  
PCT/IL2007/001482A. CLASSIFICATION OF SUBJECT MATTER  
INV. E06B5/10

According to International Patent Classification (IPC) or to both national classification and IPC

## B. FIELDS SEARCHED

Minimum documentation searched (classification system followed by classification symbols)  
E06B B32B F41H

Documentation searched other than minimum documentation to the extent that such documents are included in the fields searched

Electronic data base consulted during the international search (name of data base and, where practical, search terms used)

EPO-Internal

## C. DOCUMENTS CONSIDERED TO BE RELEVANT

Category*	Citation of document, with indication, where appropriate, of the relevant passages	Relevant to claim No.
A	FR 2 516 646 A (BOUSSOIS SA [FR]) 20 May 1983 (1983-05-20) page 4, line 9 - page 5, line 13; figure 1	1-14
A	US 4 312 903 A (MOLARI JR RICHARD E) 26 January 1982 (1982-01-26) cited in the application abstract; figures 1,2	1-14
A	US 5 778 629 A (HOWES STEPHEN E [US]) 14 July 1998 (1998-07-14) column 5, line 6 - column 6, line 31; figure 4	1-14



Further documents are listed in the continuation of Box C.



See patent family annex.

\* Special categories of cited documents:

- \*A\* document defining the general state of the art which is not considered to be of particular relevance
- \*E\* earlier document but published on or after the international filing date
- \*L\* document which may throw doubts on priority claim(s) or which is cited to establish the publication date of another citation or other special reason (as specified)
- \*O\* document referring to an oral disclosure, use, exhibition or other means
- \*P\* document published prior to the international filing date but later than the priority date claimed

- \*T\* later document published after the international filing date or priority date and not in conflict with the application but cited to understand the principle or theory underlying the invention
- \*X\* document of particular relevance; the claimed invention cannot be considered novel or cannot be considered to involve an inventive step when the document is taken alone
- \*Y\* document of particular relevance; the claimed invention cannot be considered to involve an inventive step when the document is combined with one or more other such documents, such combination being obvious to a person skilled in the art.
- \*&\* document member of the same patent family

Date of the actual completion of the international search

28 March 2008

Date of mailing of the international search report

15/04/2008

Name and mailing address of the ISA/

European Patent Office, P.B. 5818 Patentlaan 2  
NL - 2280 HV Rijswijk  
Tel. (+31-70) 340-2040, Tx. 31 651 epo nl,  
Fax: (+31-70) 340-3016

Authorized officer

Kofloed, Peter

# INTERNATIONAL SEARCH REPORT

Information on patent family members

International application No

PCT/IL2007/001482

Patent document cited in search report		Publication date		Patent family member(s)		Publication date
FR 2516646	A	20-05-1983		NONE		
US 4312903	A	26-01-1982	CA	1158536 A1		13-12-1983
US 5778629	A	14-07-1998	US	6101783 A		15-08-2000