



(19) **United States**

(12) **Patent Application Publication**

**Yap et al.**

(10) **Pub. No.: US 2004/0208760 A1**

(43) **Pub. Date: Oct. 21, 2004**

(54) **TERMINAL BLOCK ASSEMBLY FOR A HERMETIC COMPRESSOR**

(52) **U.S. Cl. .... 417/410.3**

(76) Inventors: **Zer Kai Yap**, Tecumseh, MI (US);  
**Robin G. Skinner**, Tecumseh, MI (US);  
**Ryan M. Wright**, Tecumseh, MI (US)

(57) **ABSTRACT**

Correspondence Address:  
**BAKER & DANIELS**  
**111 E. WAYNE STREET**  
**SUITE 800**  
**FORT WAYNE, IN 46802**

A hermetic compressor assembly that includes a hermetically sealed housing. A motor and compressor mechanism are disposed within the housing. The housing wall includes an aperture and a terminal block is mounted on the housing wall proximate the aperture. The terminal block forms a hermetic seal with the exterior surface of the housing wall that encircles the aperture. The seal may be formed by welding the terminal block to the exterior housing wall surface and the terminal block may be positioned entirely outwardly of the exterior surface of the housing wall and have a concave surface for engaging the housing wall. A cover may also be provided wherein the cover has a plurality of radially inwardly projecting tabs that are engageable with a latching surface on the terminal body. The latching surface may be formed by an annular groove formed in the terminal body.

(21) Appl. No.: **10/675,313**

(22) Filed: **Sep. 30, 2003**

**Related U.S. Application Data**

(63) Continuation-in-part of application No. 10/414,332, filed on Apr. 15, 2003.

**Publication Classification**

(51) **Int. Cl.<sup>7</sup> ..... F04B 35/04**

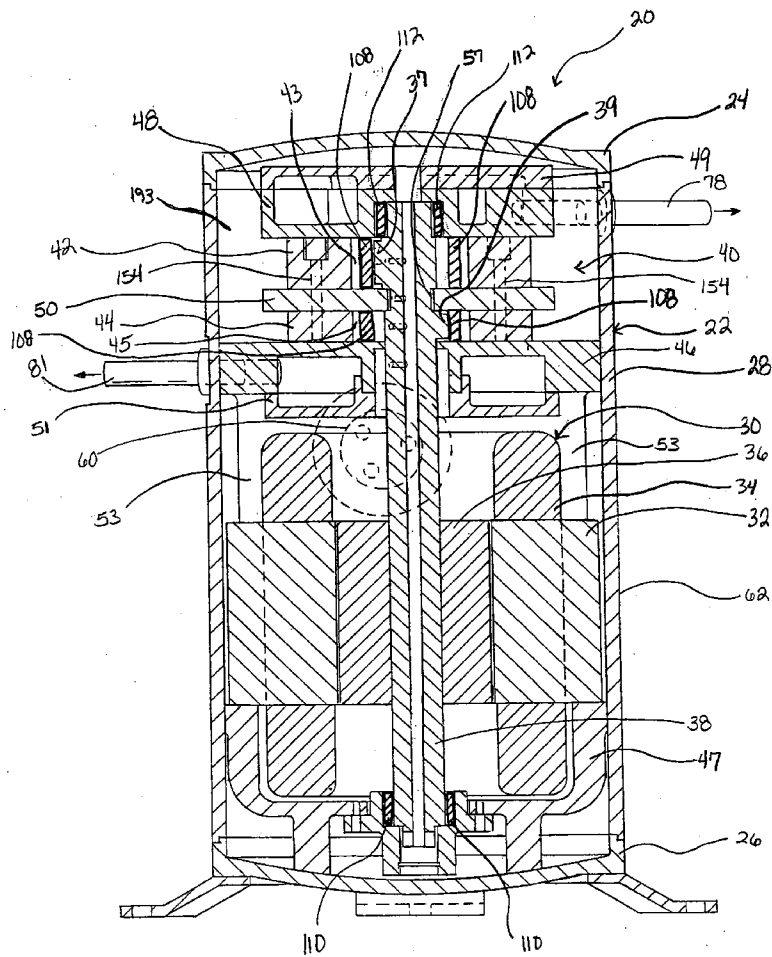

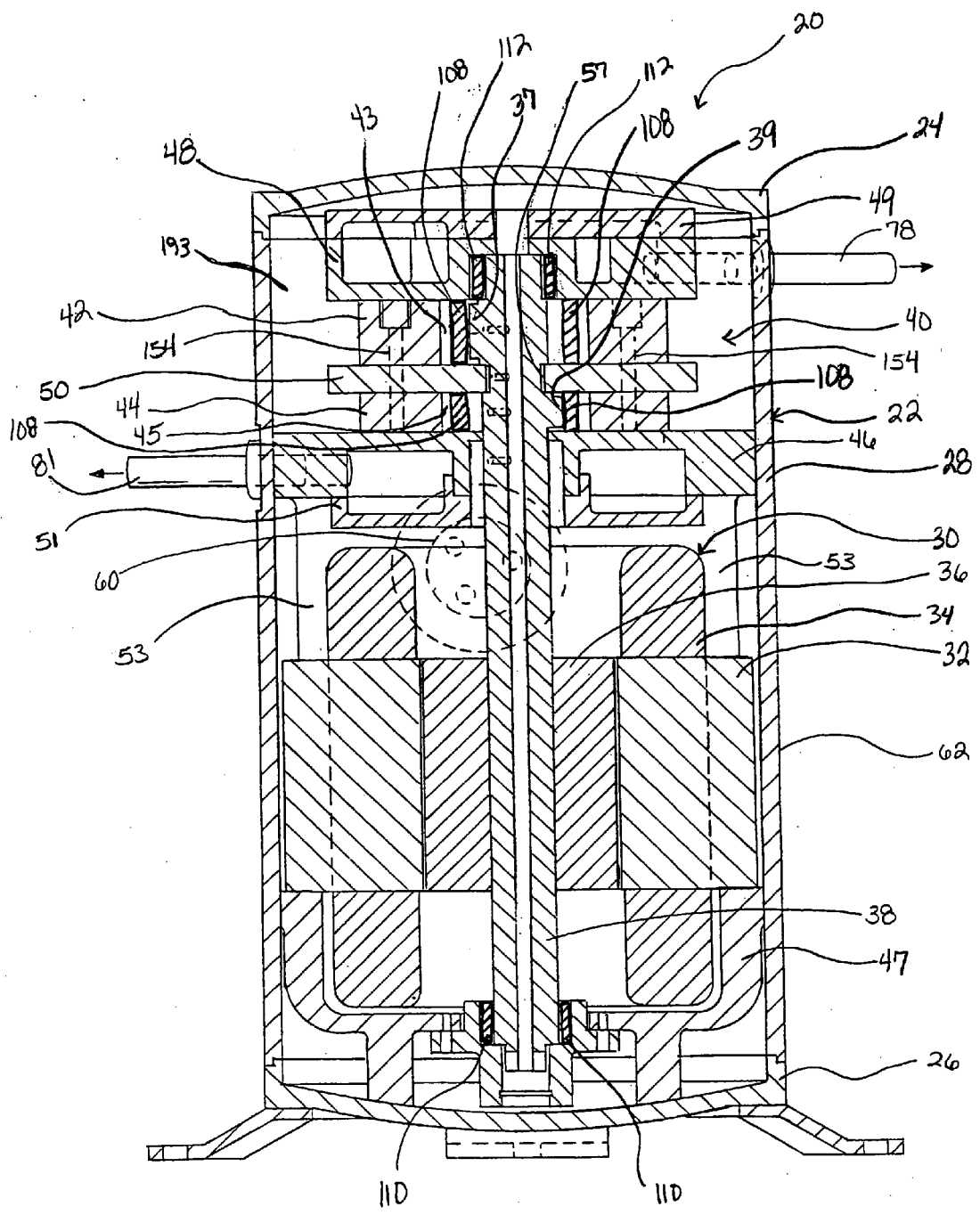

FIG. 1

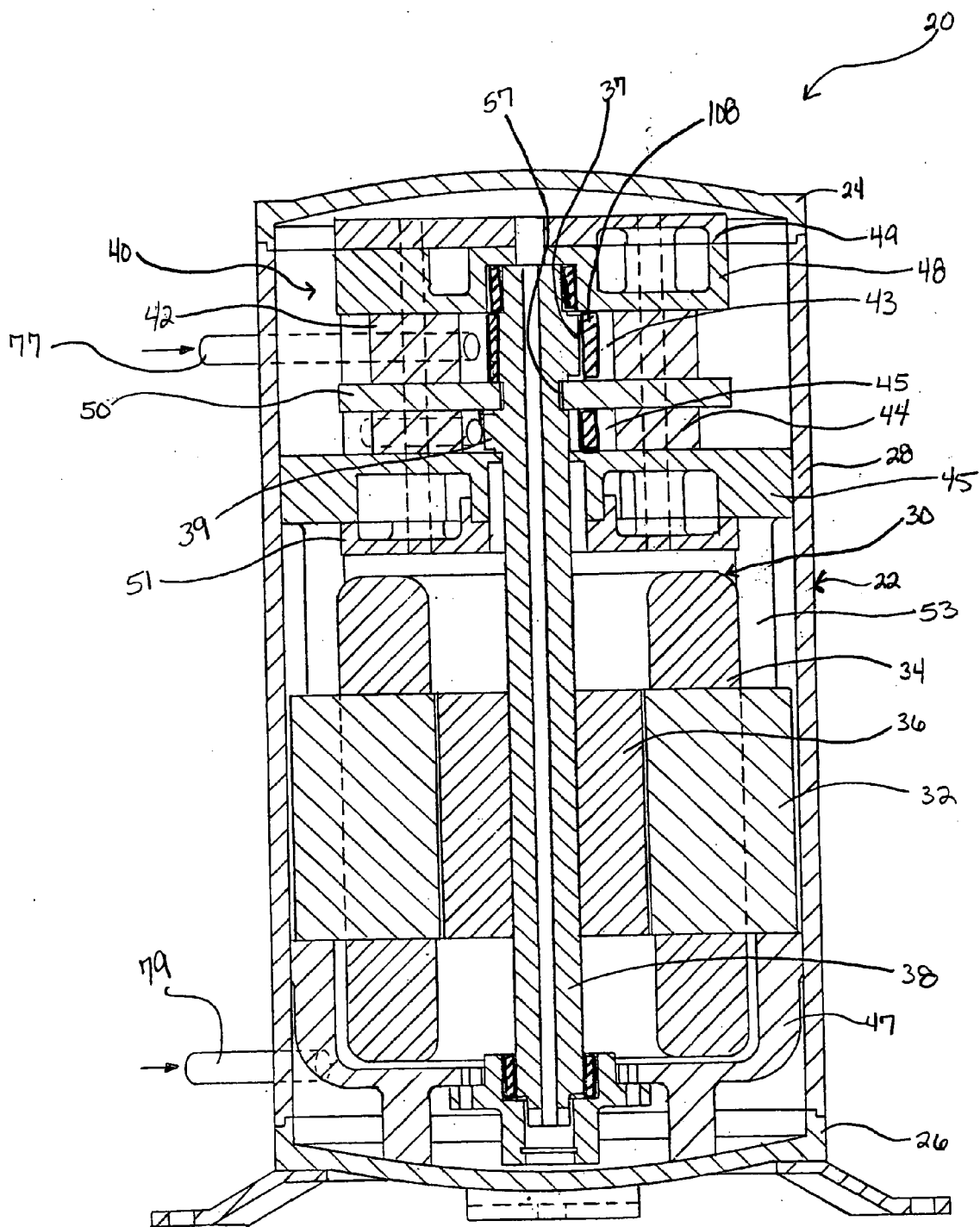

FIG. 2

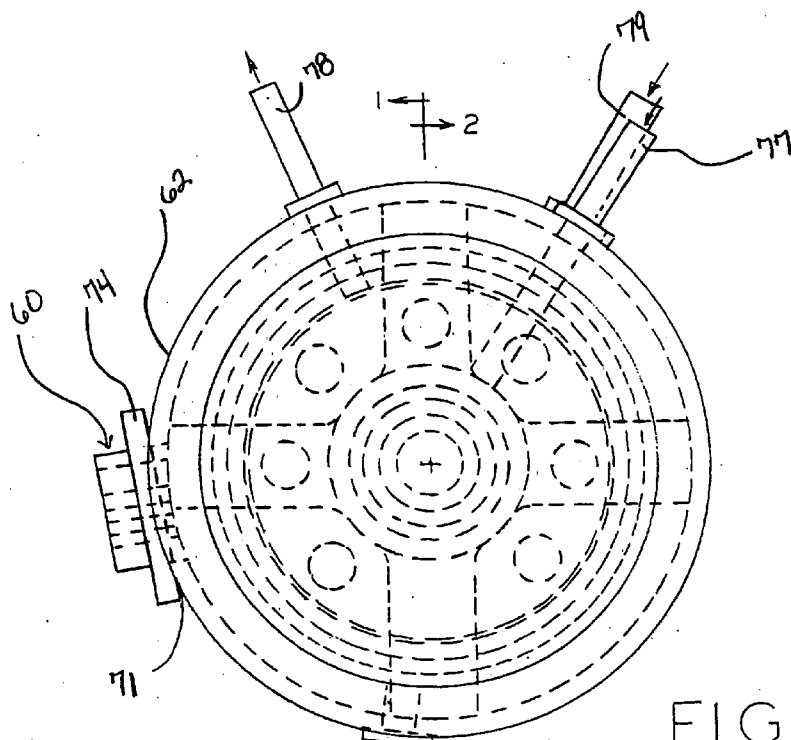

FIG. 3

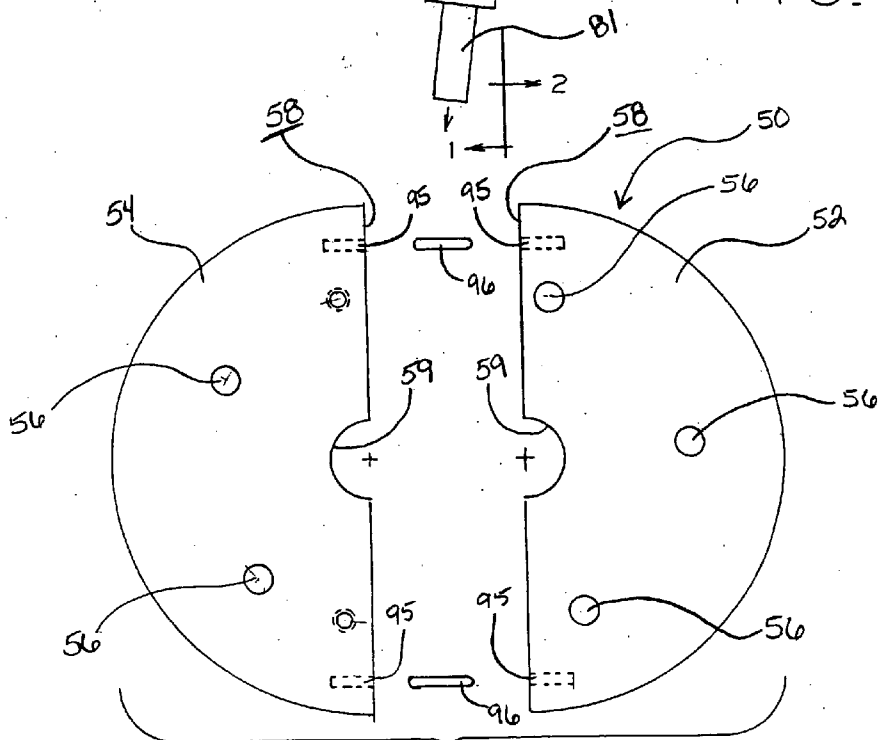

FIG. 5

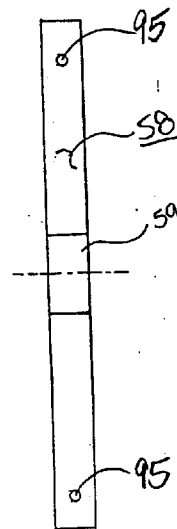

FIG. 5A

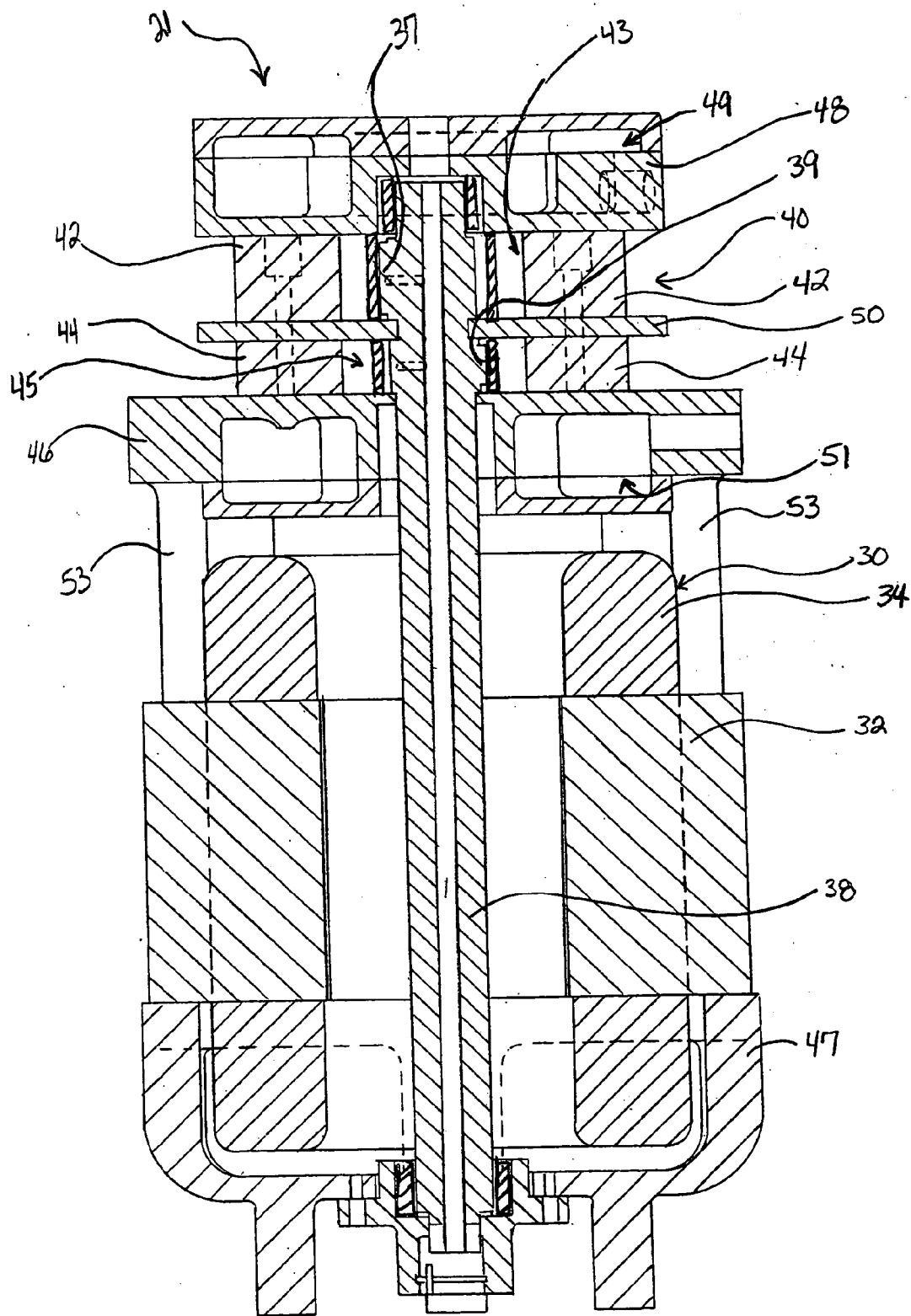
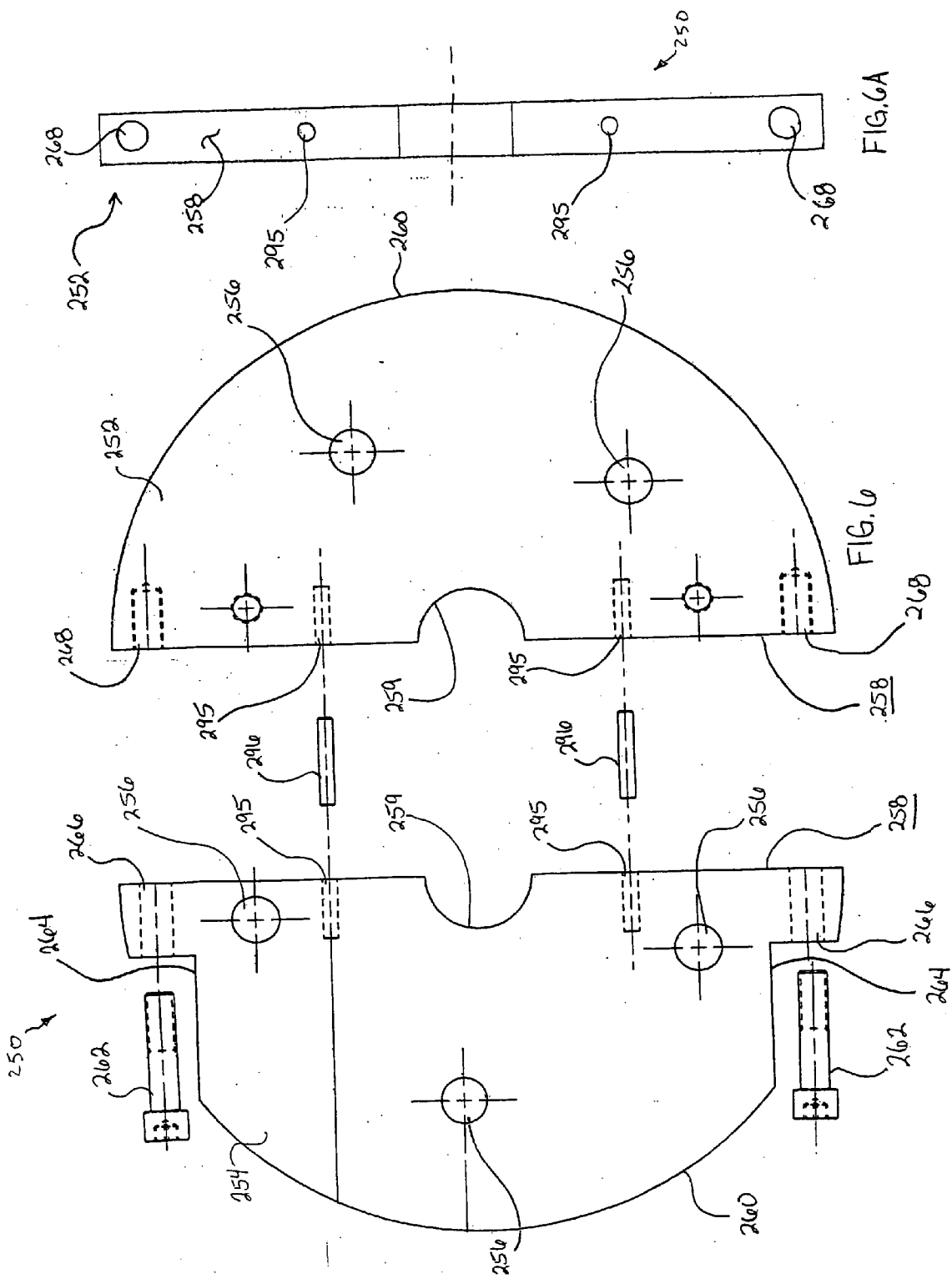

FIG. 4



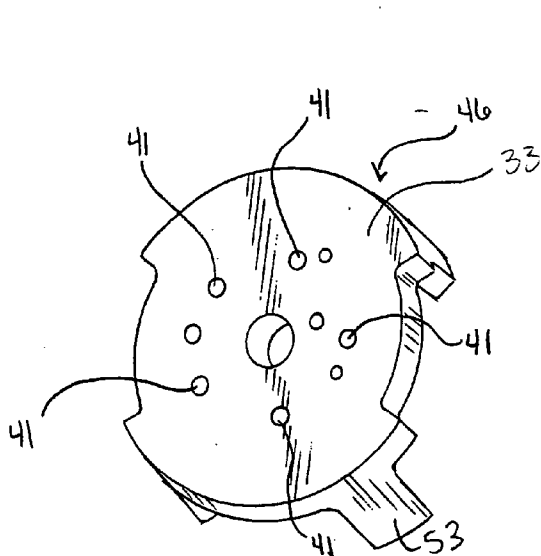

FIG. 7

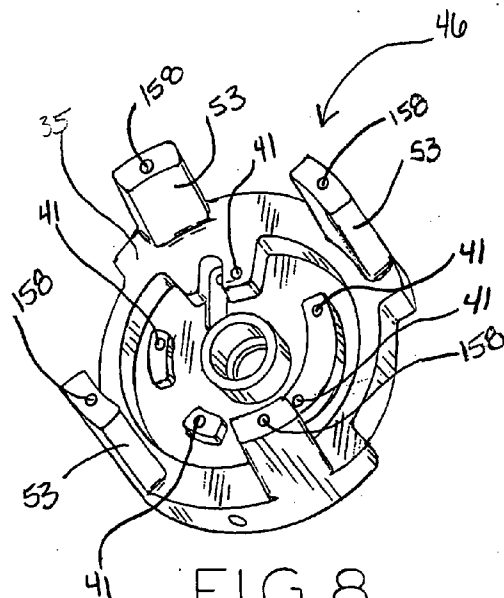

FIG. 8

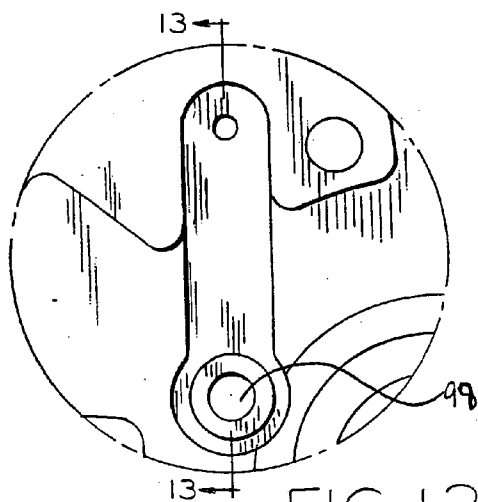

FIG. 12

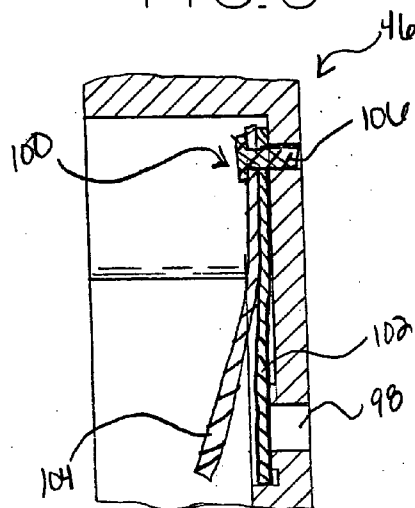

FIG. 13

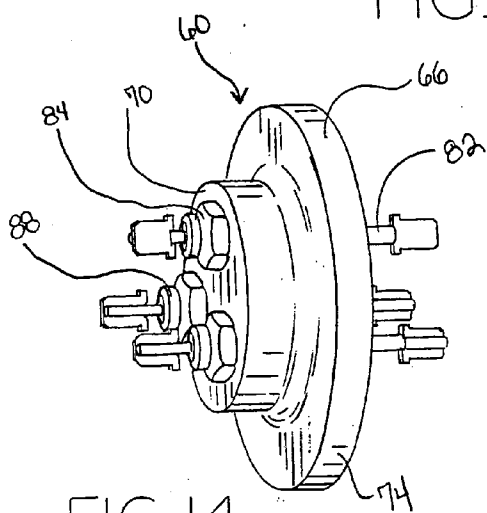

FIG. 14

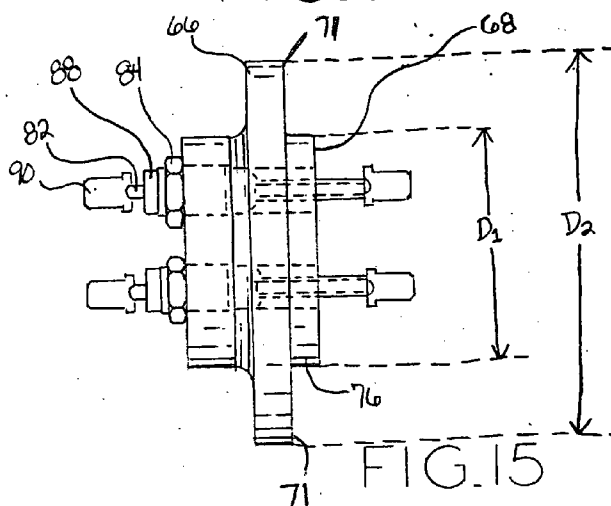

FIG. 15

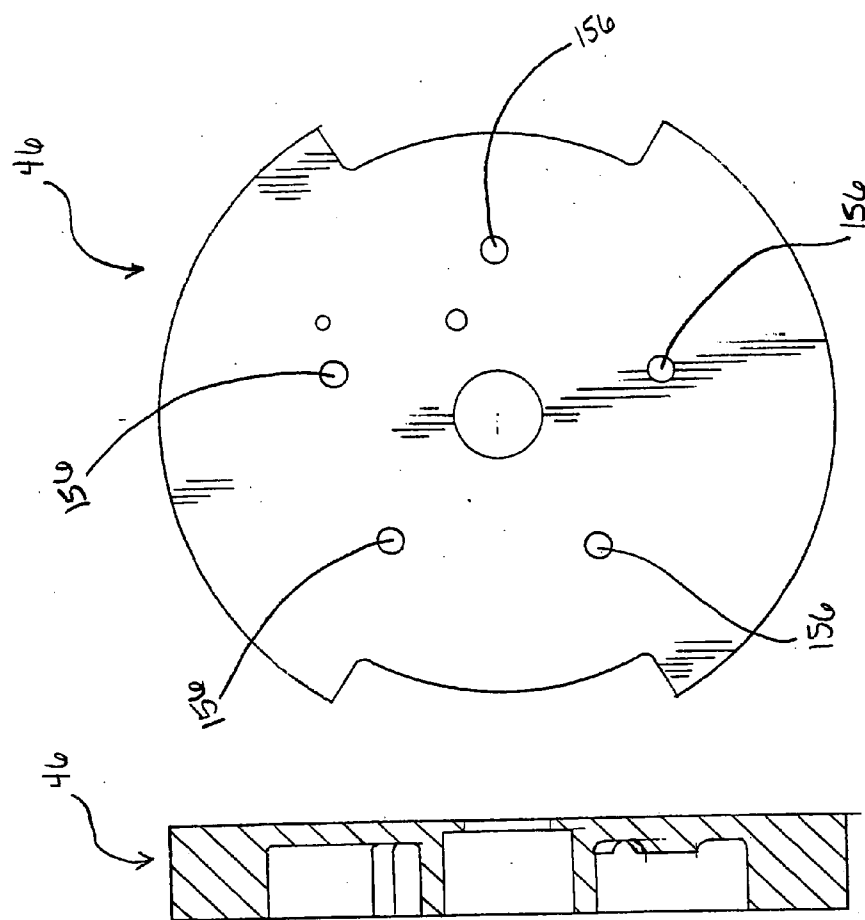

FIG. 9 FIG. 10

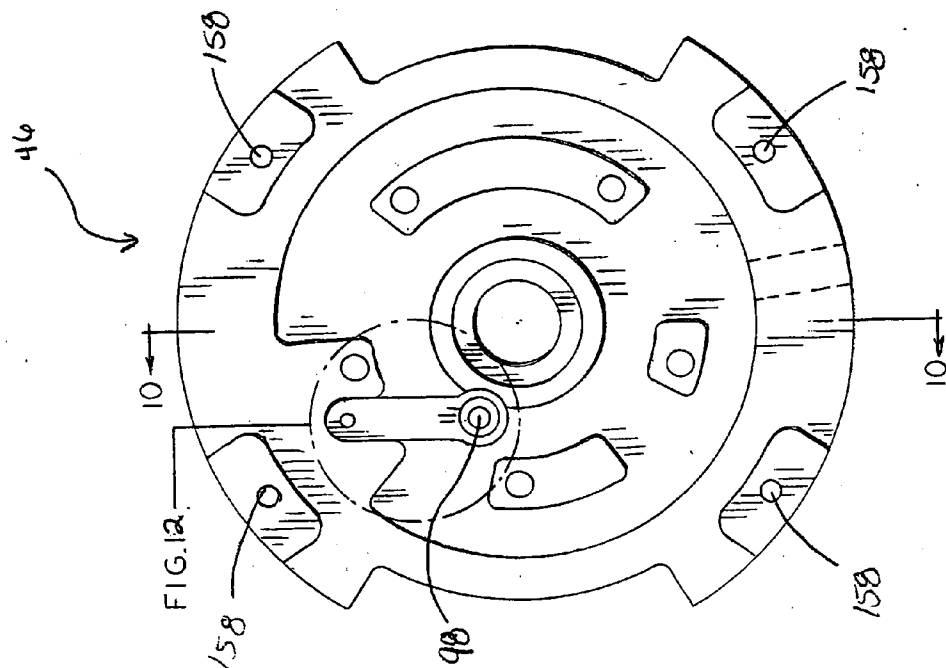

FIG. 11 FIG. 12



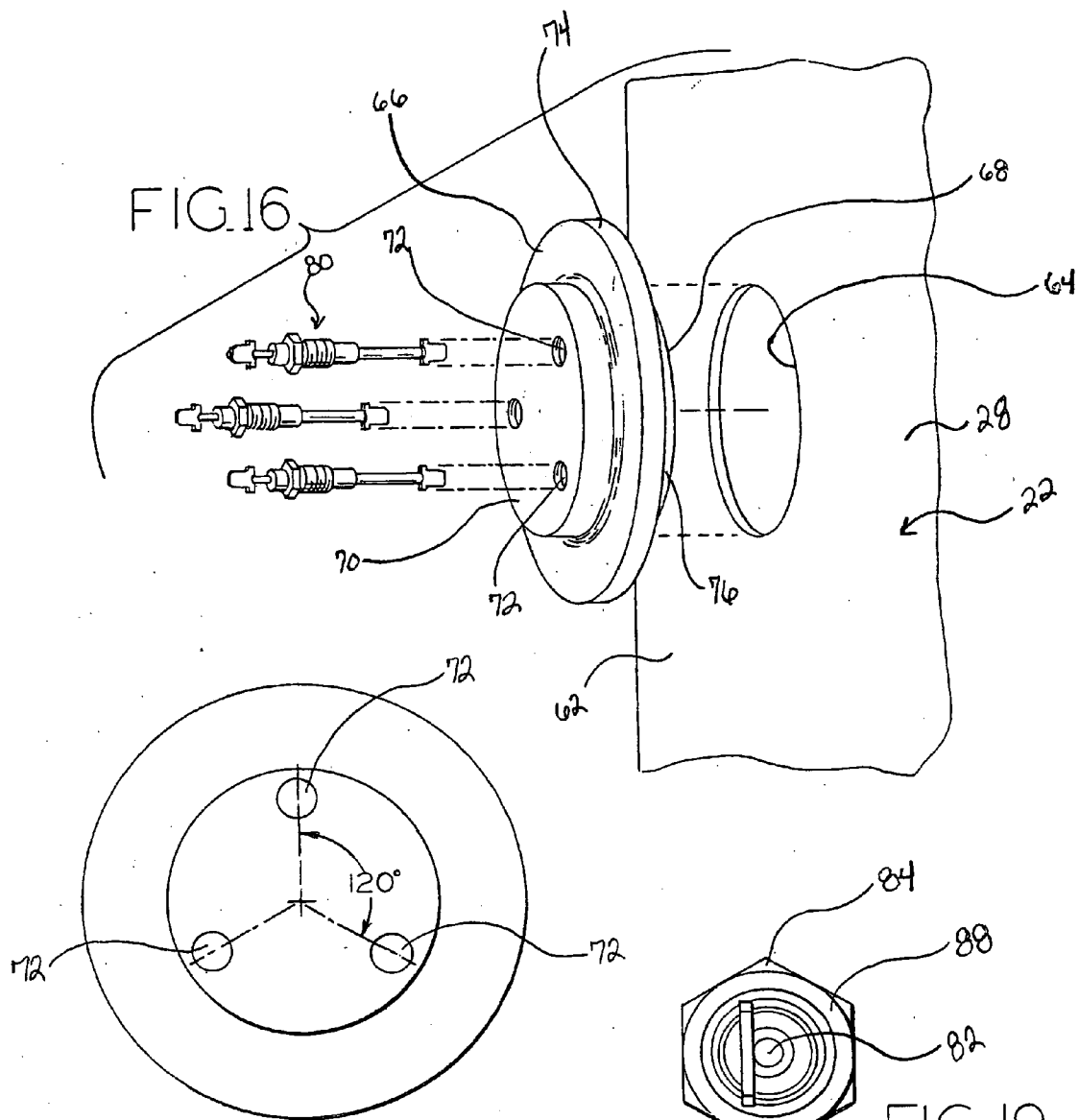

FIG. 17

FIG. 19

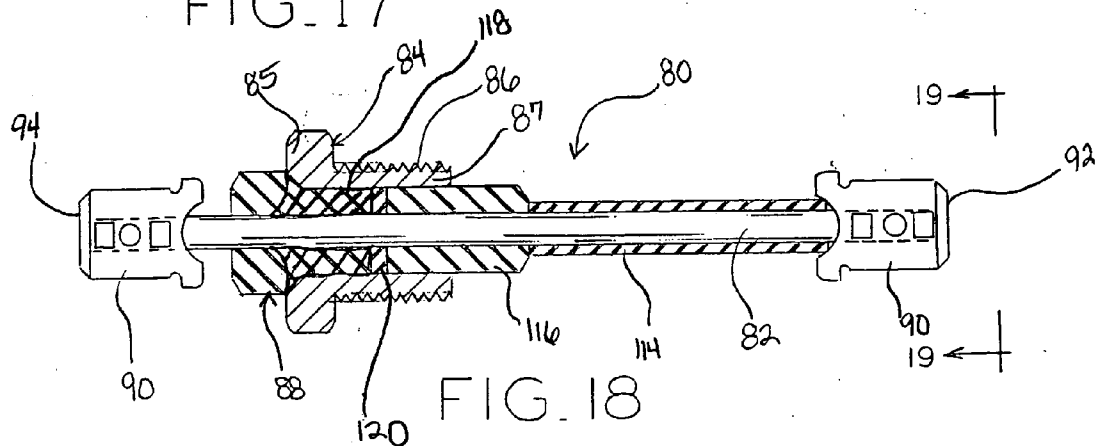

FIG. 18

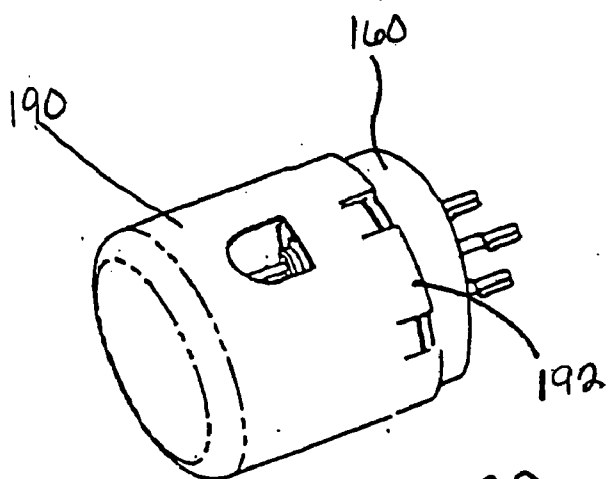

FIG. 20

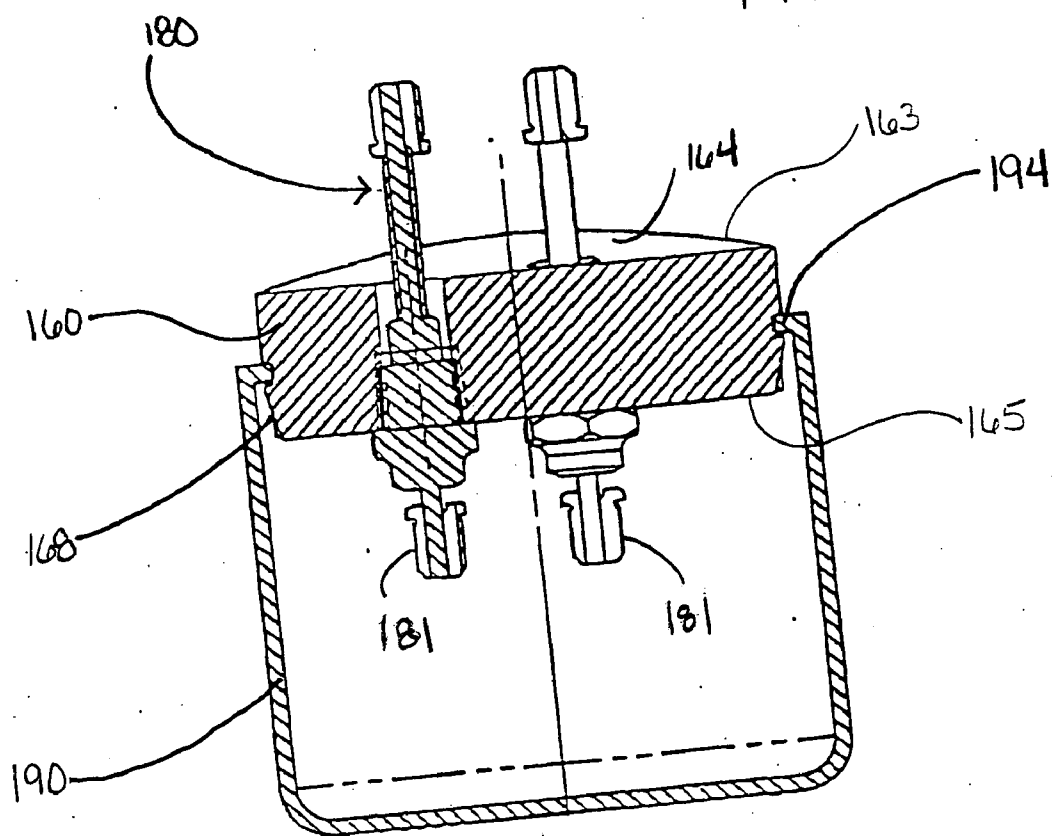
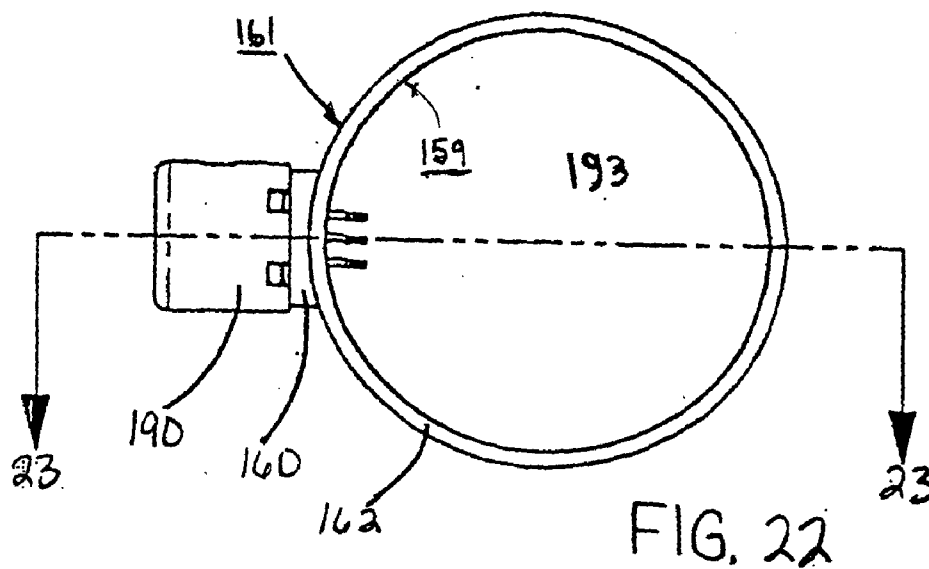
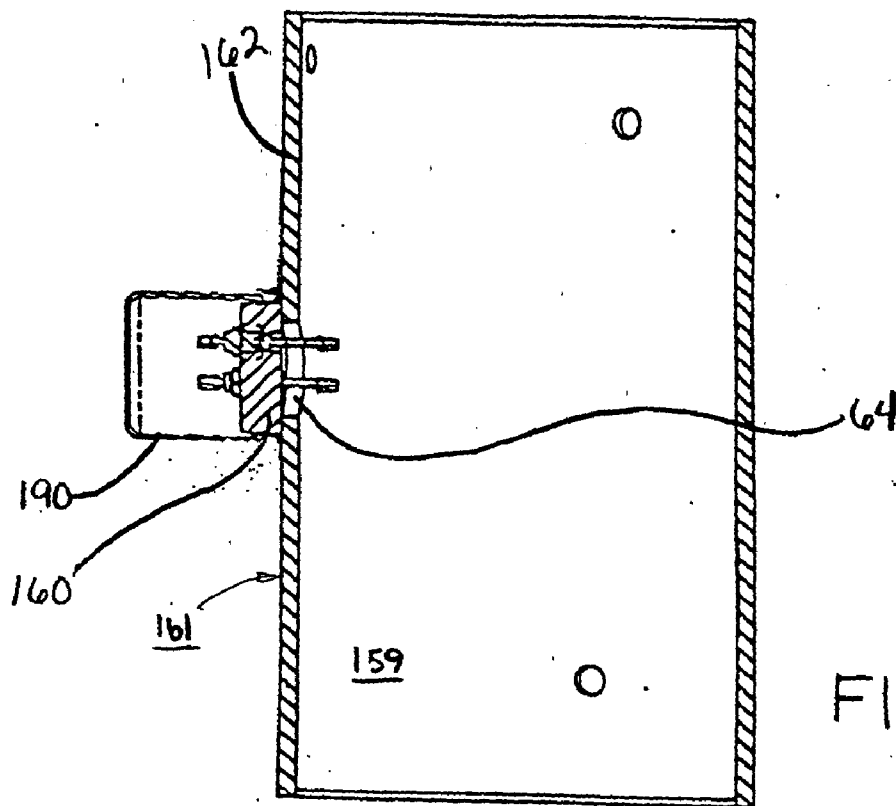
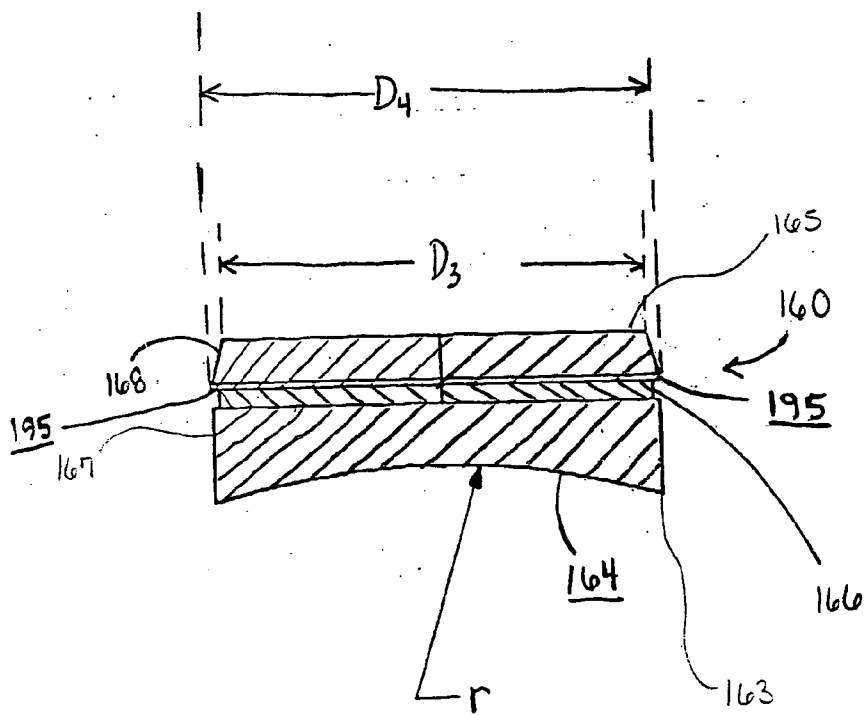
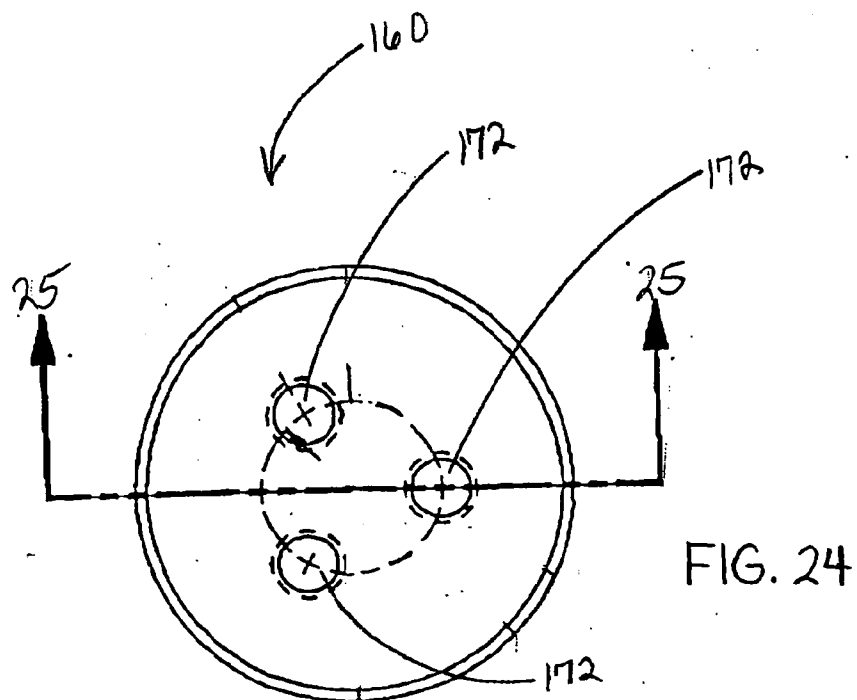
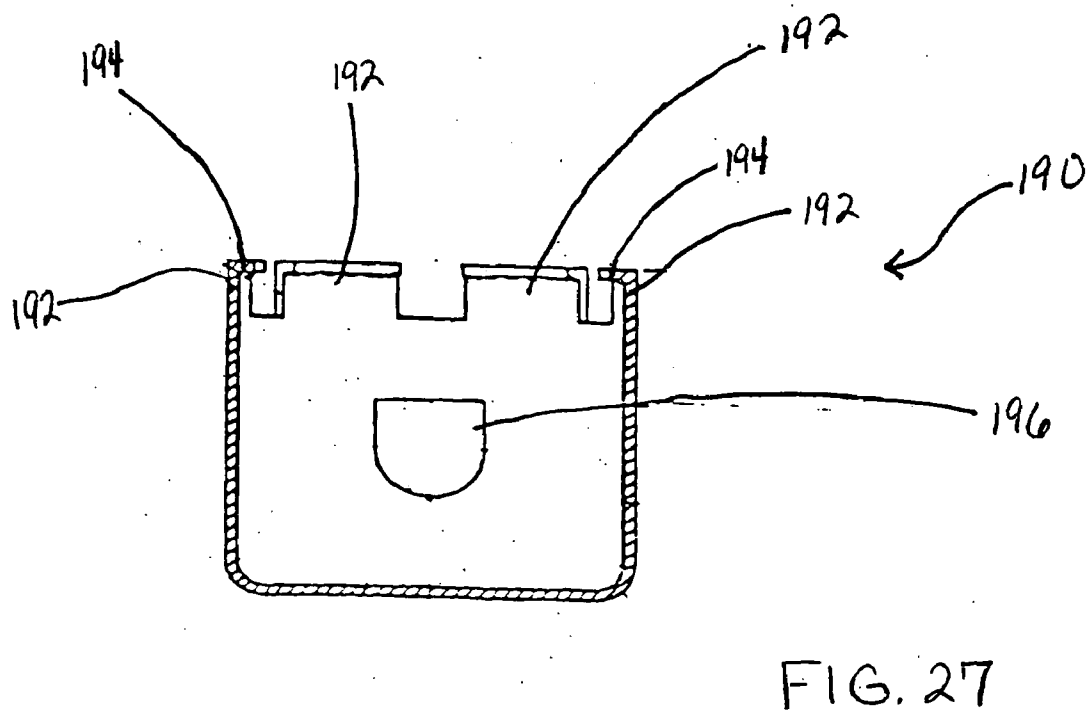
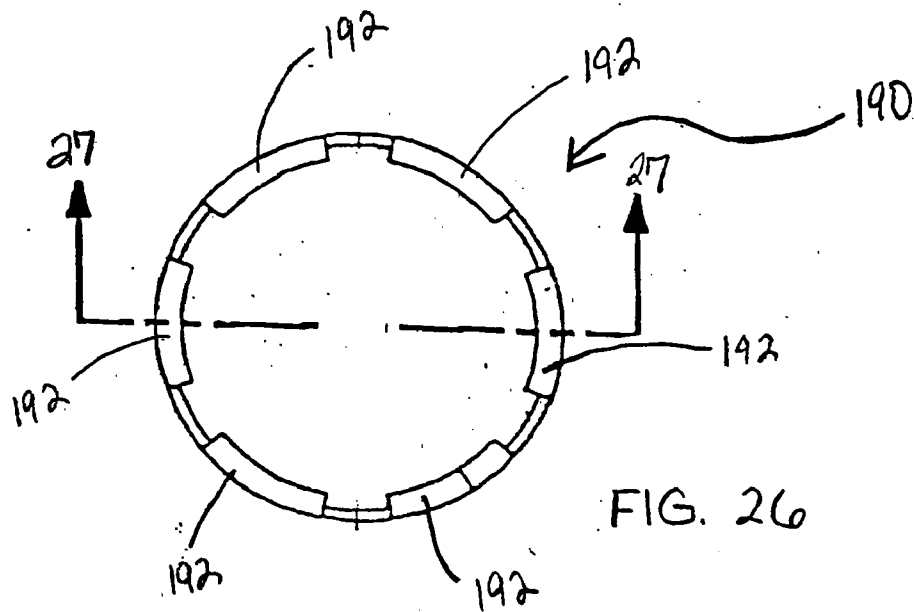

FIG. 21







## TERMINAL BLOCK ASSEMBLY FOR A HERMETIC COMPRESSOR

[0001] The present invention is a continuation-in part of pending patent application Ser. No. 10/414,332, filed Apr. 15, 2003 in the name of Zer Kai Yap and entitled "Terminal Block Assembly For A Hermetic Compressor."

### BACKGROUND OF THE INVENTION

[0002] 1. Field of the Invention

[0003] The present invention pertains to hermetically sealed compressors and, more particularly, for terminal block assemblies for such compressors.

[0004] 2. Description of the Related Art

[0005] Various types of compressors are known, including reciprocating piston, rotary vane and scroll type compressors. Oftentimes, the compressor assembly will include a hermetically sealed housing containing a motor and a compression mechanism. The motor is typically connected to a power source via a terminal assembly that is mounted in the housing.

[0006] Prior terminal assemblies, generally, include a terminal body and a plurality of conductor pins. The terminal body is typically cup-shaped and is mounted within an aperture defined in the wall of the compressor housing. The terminal body has a plurality of holes each defined by a collar or annular lip. The conductor pins extend through and are secured within the holes by the annular lip and an insulating glass seal, which electrically insulates the pins from the terminal body. The interior ends of the conductor pins are connected to lead wires running to the stator, while the exterior ends of the conductor pins protrude from the terminal body and are connected to a source of electrical power.

[0007] A fence is often provided to protect the exterior ends of the pins protruding from the terminal body. The fence typically comprises a wall that extends outwardly from the compressor housing and surrounds the terminal body and protruding pins. One end of the fence is often attached to, or integrally formed with, the terminal body. The free end of the fence is usually open and a plug or cap may fit into, or fasten onto, the free end to close the opening.

[0008] In order to prevent refrigerant leakage and accommodate the high pressures within the compressor, parts of the compressor are machined to extremely close tolerances and the compressor housing is hermetically sealed. In the case of the terminal assembly, the terminal body of the assembly is tightly fitted within an aperture of the compressor housing and is then sealed to the wall of the housing at the tightly fitting interface of the terminal body and the sidewalls of the aperture, typically by welding, brazing or the like. The terminal pins are installed in the holes of the terminal body and the fence is attached to the terminal body.

[0009] Ideally, terminal assemblies are assembled prior to mounting and welding the terminal body to the housing. However, the cup-shaped terminal body of prior terminal assemblies are often unable to withstand the high heat of welding or brazing. Consequently, the subsequent welding of the pre-assembled terminal assembly to the housing often results in damage to the terminal body, insulators and/or the conductive pins. In addition, the interior of compressors

using carbon dioxide as a working fluid may reach substantially high temperatures and pressures. Prior terminal assemblies, particularly the mountings of the conductive pins within the holes of the terminal body, are often unable to withstand the high pressures created in carbon dioxide compressors. Furthermore, the assembly of the fence and plug onto the terminal body is often complicated and adds additional parts and manufacturing time. In addition, prior compressors often required extensive machining of the housing and the housing aperture to achieve a tight fit between the terminal body and the aperture of the housing. Such extensive machining adds difficulty, time and expense to the assembly process.

[0010] Therefore, a need remains for a terminal assembly that is relatively simple to assemble, can better endure the welding process by which the terminal assembly is fixed to the compressor housing, and is better able to withstand the higher pressures and temperatures experienced in a hermetic compressor using carbon dioxide as the refrigerant.

### SUMMARY OF THE INVENTION

[0011] The present invention provides a hermetic compressor assembly that includes a terminal body that may be easily mounted on and hermetically sealed with the compressor housing without requiring the terminal body and an aperture in the housing to be manufactured using tight tolerances.

[0012] The present invention comprises, in one form thereof, an assembly for use with a hermetic compressor that includes a hermetically sealed housing defining an interior space and including a housing wall with an interior surface and an exterior surface. The housing wall defines an aperture extending through the housing wall and in communication with the interior space. A motor and a compressor mechanism operably coupled with the motor are disposed within the interior space. A terminal block is mounted on the housing wall proximate the aperture and forms a hermetic seal with the exterior surface of the housing wall. The hermetic seal encircles the aperture and at least one terminal pin is mounted in the terminal block and extends through the aperture.

[0013] The terminal block may include a mating surface that is flushly engaged with the exterior surface of the housing wall and that encircles the aperture wherein the exterior surface is cylindrical and the mating surface is a concave surface. The terminal block may be disposed entirely outwardly of the exterior surface of the housing wall or include a portion disposed within the aperture.

[0014] The invention comprises, in another form thereof, a hermetic compressor assembly that includes a hermetically sealed housing defining an interior space and including a housing wall having an interior surface and an exterior surface. The housing wall defines an aperture in communication with the interior space. A motor, and a compressor mechanism operably coupled with said motor, are disposed within said interior space. A terminal block is positioned over the aperture and is welded to the exterior surface of the housing at a location spaced radially outwardly of the aperture with at least one terminal pin being mounted in the terminal block and extending through the aperture.

[0015] The invention comprises, in yet another form thereof, a hermetic compressor assembly that includes a

hermetically sealed housing defining an interior space and including a housing wall with an interior surface and an exterior surface. The housing wall defines an aperture that extends through the wall and is in communication with the interior space. A motor and a compressor mechanism operably coupled with the motor are disposed within the interior space. A terminal block is mounted on the housing covering the aperture and forming a hermetic seal with the housing wall. The terminal block defines an annular groove and at least one terminal pin extends through the terminal block and has an end projecting outwardly from the terminal block. The assembly also includes a cover having a plurality of radially inwardly projecting tabs engageable with the groove to thereby mount the cover to the terminal block with the cover substantially enclosing the outwardly projecting end of the at least one terminal pin.

[0016] The cover may include a plurality of resilient mounting members extending therefrom with the tabs being disposed on respective distal ends of the plurality of resilient mounting members. The terminal block may also include a guide surface disposed between said annular groove and a distal end of said terminal block wherein the guide surface tapers radially inwardly as the guide surface projects from the latching surface to the distal end. Such a guide surface may have a frustoconical shape.

[0017] The present invention comprises, in still another form thereof, a method of assembling a hermetic compressor. The method includes providing a housing having a housing wall with an interior surface and an exterior surface, forming an aperture in the housing wall, and installing at least one terminal pin in a terminal block. The method also involves mounting the terminal block on the housing wherein the terminal block covers the aperture and forming a hermetic seal between the terminal block and the exterior surface of the housing wall wherein said hermetic seal circumscribes the aperture.

[0018] The steps of mounting the terminal block to the housing and forming the hermetic seal between the terminal block and the exterior surface of the housing wall may both comprise welding the terminal block to the exterior surface of the housing wall. The step of installing at least one terminal pin assembly in the terminal block may include threadingly engaging the terminal pin assembly with the terminal block and such step may occur either after or prior to mounting the terminal block on the housing.

#### BRIEF DESCRIPTION OF THE DRAWINGS

[0019] The above-mentioned and other features and objects of this invention, and the manner of attaining them, will become more apparent and the invention itself will be better understood by reference to the following description of embodiments of the invention taken in conjunction with the accompanying drawings, wherein:

[0020] FIG. 1 is a first sectional view of a hermetic compressor according to the present invention;

[0021] FIG. 2 is a second sectional view of the hermetic compressor of FIG. 1;

[0022] FIG. 3 is a top view of the compressor of FIG. 1;

[0023] FIG. 4 is a sectional view of the compressor sub-assembly of FIG. 1;

[0024] FIG. 5 is a top view of a two-piece separator plate according to one embodiment of the present invention;

[0025] FIG. 5A is an interior side view of either piece of the separator plate of FIG. 5;

[0026] FIG. 6 is a top view of a two-piece separator plate according to another embodiment of the present invention;

[0027] FIG. 6A is an interior side view of a first piece of the separator plate of FIG. 6;

[0028] FIG. 7 is a top perspective view of a crankcase according to the present invention;

[0029] FIG. 8 is bottom perspective view of the crankcase of FIG. 7;

[0030] FIG. 9 is a bottom view of the crankcase of FIG. 7;

[0031] FIG. 10 is a sectional view taken along line 10-10 of FIG. 9;

[0032] FIG. 11 is a top view of the crankcase of FIG. 7;

[0033] FIG. 12 is an enlarged view of the encircled region of FIG. 9;

[0034] FIG. 13 is an enlarged, fragmentary sectional view taken along line 13-13 of FIG. 12;

[0035] FIG. 14 is a perspective view of a terminal block assembly according to the present invention;

[0036] FIG. 15 is a side view of the terminal block assembly of FIG. 14;

[0037] FIG. 16 is an exploded view of the terminal block assembly of FIG. 14 in relation with the housing of a hermetic compressor according to the present invention;

[0038] FIG. 17 is a front view of the terminal block assembly of FIG. 14;

[0039] FIG. 18 is an enlarged sectional view of a pin assembly according to the present invention;

[0040] FIG. 19 is an end view taken along line 19-19 of FIG. 18;

[0041] FIG. 20 is a perspective view of a second embodiment terminal assembly and protective cover according to the present invention;

[0042] FIG. 21 is a sectional view of the terminal assembly and protective cover of FIG. 20;

[0043] FIG. 22 is a top view of the terminal assembly and protective cover of FIG. 20 installed on a compressor housing according to the present invention;

[0044] FIG. 23 is a sectional view taken along line 23-23 of FIG. 22;

[0045] FIG. 24 is a plan view of the terminal block of the terminal assembly FIG. 20;

[0046] FIG. 25 is a sectional view taken along line 25-25 of FIG. 24;

[0047] FIG. 26 is a bottom view of the protective cover of FIG. 22; and

[0048] FIG. 27 is a sectional view taken along line 27-27 of FIG. 26.

[0049] The embodiments disclosed herein are not intended to be exhaustive or limit the invention to the precise forms disclosed in the following description. Rather the embodiments are chosen and described so that others skilled in the art may utilize its teachings.

#### DETAILED DESCRIPTION

[0050] Referring to FIG. 1, hermetic compressor 20 comprises housing 22 which includes upper housing 24, lower housing 26, and cylindrical main housing 28. As better illustrated in FIG. 16, aperture 64 is defined in wall 62 of main housing 28. Returning now to FIG. 1, housing portions 24, 26 and 28 are formed of sheet steel having a thickness of between about 0.2 inches (0.508 cm) and 0.4 inches (1.02 cm). Housing portions 24, 26, and 28 are hermetically sealed by a method such as welding, brazing, or the like. Alternatively, either upper housing 24 or lower housing 26 may be integrally-formed with main housing 28. Disposed within housing 22 is motor 30 and compression mechanism 40. Motor 30 includes rotor 36, which is surrounded by stator 32 and fixed to crankshaft 38. Stator 32 includes windings 34, which are connected by lead wires (not shown) to a power source (not shown) via terminal assembly 60. Stator 32 is secured at one end to legs 53 of crankcase or main bearing 46 and at the opposite end to lower outboard bearing 47. Discharge muffler 51 is disposed between main bearing 46 and motor 30.

[0051] Compression mechanism 40 includes first cylinder 42 and second cylinder 44, each having a cylindrical chamber 43 and 45, respectively. First and second cylinders 42, 44 are separated by separator plate 50, which has a central bore 57. Chamber 43 of first cylinder 42 receives gas, which may be, for example, carbon dioxide or any other suitable refrigerant, at substantially suction pressure, through intake tube 77. Intermediate pressure muffler 49 is disposed on upper outboard bearing 48 and upper outboard bearing 48 is disposed adjacent first cylinder 42. Upper outboard bearing 48 includes intermediate discharge tube 78, which is in communication with chamber 43 of first cylinder 42. Intermediate discharge tube 78 is also in communication with chamber 45 of second cylinder 44 through intermediate suction tube 79 (FIGS. 2 and 3). Intermediate discharge tube 78 and intermediate suction tube 79 are in fluid communication with each other externally of housing 22, and may comprise a common conduit.

[0052] Second cylinder 44 is disposed adjacent to main bearing 46 and chamber 45 is in communication with discharge muffler 51 through valve opening 98 in main bearing 46 (FIGS. 9, 12 and 13). Referring to FIGS. 9, 12 and 13, valve opening 98 is equipped with a valve assembly 100 that includes resilient valve 102 sealing valve opening 98 and valve stop 104. Valve assembly 100 is secured to main bearing 46 by fastener 106. Referring back to FIGS. 1-3, discharge tube 81 is in communication with discharge muffler 51. Crankshaft 38 extends through chamber 45, bore 57, and chamber 43, and includes two eccentric portions 37, 39 mounted thereon which are disposed inside chambers 43 and 45, respectively. Roller bearings 108 provide radial support to eccentric portions 37, 39 and further seal any space between the wall of bore 57 and crankshaft 38. Crankshaft 38 is radially supported at either end in lower outboard bearing 47 and upper outboard bearing 48 by needle roller bearings 110, 112, which prevent deflection of crankshaft 38.

[0053] Turning now to FIGS. 1-3, in operation, compressor 20 receives suction pressure gas into first compression chamber 43 through tube 77, where it is compressed to an intermediate pressure and discharged into intermediate pressure muffler 49. The intermediate pressure gas is then discharged externally from compressor 22 through intermediate discharge tube 78, which extends from outboard bearing 48 and through housing 22. The intermediate pressure gas is then introduced into the motor compartment through intermediate pressure suction tube 79, and is drawn into second compression chamber 45 and compressed to discharge pressure. Referring now to FIGS. 1-3 and 13, the discharge pressure gas is discharged into discharge muffler 51 from second compression chamber through valve opening 98 in main bearing 46. More specifically, when pressure reaches a certain pre-determined limit, the pressure of the discharge pressure gas forces valve 102 to deflect away from main bearing 46, thereby exposing valve opening 98 to discharge muffler 51. The deflection of valve 102 is limited by valve stop 104. The discharge gas is then expelled from the compressor assembly through discharge tube 81, which extends from main bearing 46 and through housing 22. The displacement volume ratio of intermediate pressure gas to discharge pressure gas is approximately 1:10.

[0054] According to one embodiment of the present invention shown in FIG. 5, separator plate 50 is a two-piece separator plate having a first piece 52 and a second, complementary piece 54. As illustrated in FIGS. 5 and 5A, each of first and second pieces 52, 54 includes planar surface 58 having semi-circular central recess 59. First and second pieces 52, 54 may be paired by joining planar surfaces 58 and fastening first and second pieces using dowel 96, the ends of which are received within dowel holes 95. When first and second pieces 52, 54 are paired, semi-circular recesses 59 form bore 57, which is sized to closely surround crankshaft 38 at a location between the eccentrics. Two-piece separator plate 50 also includes bolt clearance holes 56. The two-piece plate design allows the separator plate 50 to be fitted more closely around the portion of crankshaft 38 located between eccentrics 37, 39 and sealably separate compression chambers 43 and 45.

[0055] According to another embodiment of the present invention shown in FIG. 6, separator plate 250 is a two-piece separator plate having a first piece 252 and a second, complementary piece 254. As illustrated in FIGS. 6 and 6A, each of first and second pieces 252, 254 includes annular surface 260 and planar surface 258 having semi-circular central recess 259. First and second pieces 252, 254 may be paired by joining planar surfaces 258 and fastening first and second pieces 252, 254 using dowel 296, the ends of which are received within dowel holes 295. Alternatively, or additionally, first and second pieces 252, 254 may be secured using fasteners 262, which extend through clearance apertures 266 in second piece 254 and engage threaded apertures 268 defined in interior surface 258 of first piece 252. Notches 264 may be defined in annular surface 260 of second piece 254 for receiving fasteners 262 and for housing the head of fasteners 262 within the diametric perimeter of annular surface 260. Two-piece separator plate 250 also includes bolt clearance holes 256.

[0056] In assembling compressor 20 according to the present invention, main bearing 46 is placed on a holding device with the upper side 33 facing up. Second cylinder 44



is then placed on the upper side 33 of main bearing 46 and crankshaft 38 is inserted into main bearing 46 and second cylinder 44. Roller bearing 108 is mounted on crankshaft 38 within chamber 45. First and second pieces 52, 54 of separator plate 50 are then positioned on top of second cylinder 44 and paired such that semi-circular central recesses 59 closely capture the portion of crankshaft 38 located between eccentrics 37, 39. First and second pieces 52, 54 are connected to one another using dowels 96, the ends of which are inserted into holes 95 (FIG. 5). Alternatively, first and second pieces 252, 254 of separator plate 250 may be positioned on top of second cylinder 44 and paired such that semi-circular central recesses 259 closely capture the portion of crankshaft 38 located between eccentrics 37, 39. First and second pieces 252, 254 may then be connected to one another using dowels 296 and/or fasteners 262. Roller bearing 108 is mounted on crankshaft 38 and first cylinder 42 is then positioned on separator plate 50 such that roller bearing is disposed within chamber 43.

[0057] Outboard bearing 48 and intermediate discharge muffler 49 are then positioned atop first cylinder 42 and five bolts (represented by dashed lines 154 in FIG. 1) are placed through clearance holes in intermediate discharge muffler 49, outboard bearing 48, first cylinder 42, two-piece separator plate 50, and second cylinder 44, and engage threaded holes 41 (FIG. 7) in the upper side 33 of main bearing 46. Next, main bearing 46 is removed from the holding device and annular discharge muffler 51 is positioned on the underside 35 of main bearing 46 between legs 53. Five bolts are then inserted through clearance holes in discharge muffler 51 and engage one end of threaded holes 41 at the underside 35 of main bearing 46 (FIG. 8) to secure discharge muffler 51 to main bearing 46. Alternatively, the five bolts 154 extending through intermediate discharge muffler 49, outboard bearing 48, first cylinder 42, two-piece separator plate 50, second cylinder 44, and holes 41 can be lengthened to further extend completely through holes 41 and discharge muffler 51 and can be secured with nuts.

[0058] Crankshaft 38 is then affixed to rotor 36 by heat-shrinking. Stator 32 is then placed over rotor 36, and outboard bearing 47 is positioned over the end of stator 32 and rotor 36. Four threaded bolts or like fasteners (not shown) are inserted into clearance holes (not shown) provided in outboard bearing 47 and stator 32. Bolts are then threaded into four threaded holes 158 provided in the ends of legs 53 of main bearing 46 (FIG. 8).

[0059] The resulting compressor sub-assembly 21, shown in FIG. 4, is then installed in housing 22 by, first, heat-expanding main housing 28, and inserting compressor sub-assembly 21 into main-housing 28 (FIG. 1). Main housing 28 is then allowed to cool thereby shrink-fitting housing 28 onto sub-assembly 21, such that sub-assembly 21 is in contact with the housing at the peripheries of main bearing 46 and outboard bearing 47. The upper and lower housing portions are then welded to the main housing portion 28 to hermetically seal compressor 20. Tubes 77, 78, 79, and 81 are then inserted into openings (not shown) in housing 28 such that the inner portion of tubes 77, 78, 79 and 81 extend into openings (not shown) in first cylinder 42, outboard bearing 48, outboard bearing 47 and main bearing 46, respectively. The openings in first cylinder 42, outboard bearing 48, outboard bearing 47 and main bearing 46 are provided with a seal, such as an o-ring, to sealingly receive

tubes 77, 78, 79 and 81. The outer portion of tubes 77, 78, 79 and 81 are then sealed to housing 38 by welding, brazing or the like.

[0060] With reference to FIGS. 14-19, according to one embodiment of the present invention, terminal assembly 60 generally includes machined metallic disk 66 and three pin assemblies 80. Disk 66 includes three equally spaced-apart, threaded holes extending therethrough. Referring particularly to FIGS. 15 and 16, interior side 68 of disk 66 defines a first diameter portion 76 having diameter  $D_1$  sized to snugly fit within aperture 64 in wall 62 of housing 22. Disk 66 also includes a second diameter portion 74 adjacent first diameter portion 76 and having diameter  $D_2$ , which is larger in diameter than both  $D_1$  and aperture 64. As shown in FIGS. 3 and 16, first diameter portion 76 of disk 66 fits into aperture 64. Second diameter portion 74 abuts wall 62, thereby restricting further movement of disk 66 into aperture 64 and providing a sealing region 71 between the surface of second diameter portion 74 and housing wall 62. Disk 66 is hermetically sealed to the exterior surface of housing wall 62 at sealing region 71 located at the radially outer edge of larger diameter portion 74 of disk 66 by welding, brazing or other means that fully encircle aperture 64.

[0061] Turning now to FIGS. 18 and 19, each pin assembly 80 includes an elongate conductive pin 82, electrical insulator 88 disposed about pin 82, annular collar 84 disposed about a portion of electrical insulator 88, and tabs 90 positioned at both the interior end 92 and exterior end 94 of pin 82. Electrical insulator 88 includes Teflon® sleeve 114 extending along a length of pin 82 at interior end 92, sintered glass portions 116, and a fused glass portion 118. Between fused glass portion 118 and one of the sintered glass portions 116 is freon-proof epoxy resin 120, and parts of both fused glass portion 118 and sintered glass portion 116 are disposed between pin 81 and annular collar 84. Annular collar 84 includes hexagonal head portion 85 and shaft portion 87, which includes threaded outer surface 86. Each pin assembly 80 is received in a corresponding one of threaded holes 72 in disk 66 and is secured in hole 72 via a threaded engagement between threaded collar surface 86 and threaded surface of hole 72. In this threaded engagement, pin assemblies 80 are more securely fixed in holes 72, and therefore, are capable of withstanding the high pressures created in carbon dioxide compressors.

[0062] As is typical in the art, the interior end 92 of pin 82 may be connected to lead wires (not shown) extending from stator windings 34 via a connector clip, cluster block or other electrical connecting means. The exterior end 94 of pin 82 is appropriately connected to a power source (not shown) to provide power to pin 82 and, ultimately, to stator 32.

[0063] Disk 66 is a metal casting, such as steel, that is capable of enduring the heat of welding and/or brazing, and is machined to final shape. Disk 66 is of substantial thickness, the overall thickness of disk 66 as measured between exterior side 70 and interior side 68 is, preferably, about one inch. However, thickness can vary, provided that disk 66 is thick enough to endure the heat of hermetic sealing and the pressures of carbon dioxide compression without damage or deformity to disk 66 or pin assemblies 80. Second diameter portion 74, particularly, should be of substantial thickness, preferably, about 0.300 inches. First diameter portion 76 should have sufficient thickness to securely fit into aperture 64, preferably, about 0.200 inches.

[0064] This terminal assembly withstands the heat of welding and the pressures created in a carbon dioxide compressor, and therefore, provides a more robust compressor assembly design. In one embodiment of the present invention, the terminal assembly is assembled by, first, mounting metallic disk 66 on housing 22 by inserting first diameter portion 76 into aperture 64 until second larger diameter portion 74 of metallic disk 66 engages outer wall 62 of housing 22. Then second diameter portion 74 is hermetically sealed to housing outer wall 62 by welding, brazing or the like around the perimeter of second diameter portion 74. Finally, terminal pin assemblies 80 are inserted into holes 72 and annular collars 84 are secured to hole 72 in a threaded engagement.

[0065] Alternatively, the terminal assembly can be assembled prior to welding disk 66 to wall 62 of housing 22. In this case, terminal assembly 60 is assembled by, first, installing terminal pin assemblies 80 within holes 72, as described above. With the pin assemblies 80 threadedly secured in holes 72, metallic disk 66 is mounted in aperture 64 and second diameter portion 74 is hermetically sealed to outer wall 62 without causing damage to disk 66 or pin assemblies 80.

[0066] According to another embodiment of the present invention exemplified in FIGS. 20-27, terminal block 160 is a solid, metallic cylindrical block having mating end 163 and distal or projecting end 165. As can be seen in FIGS. 21 and 24, terminal block 160 also includes three equally-spaced, tapped and threaded holes 172 extending through terminal block 160 from mating end 163 to projecting end 165. Holes 172 receive terminal pin assemblies 180 in a threaded-engagement as described above with respect to pin assemblies 80. Terminal block 160 is a metal casting, e.g., steel, that is capable of enduring the heat of welding and brazing, and is machined to form the final shape. Terminal block 160 is of substantial thickness, the overall thickness of terminal block 160 as measured along the axis between mating end 163 and projecting end 165 is, preferably, between about 0.5 inches (1.27 cm) to about 1 inch (2.54 cm). However, the thickness can vary, provided that terminal block 160 is thick enough to endure the heat of hermetic sealing and the pressures of carbon dioxide compression without damage or deformity to terminal block 160 or pin assemblies 180.

[0067] Referring now to FIGS. 22, 23 and 25, mating end 163 has a concave mating surface 164 having a radius of curvature that corresponds to the curvature of exterior surface 161 of housing wall 162, such that mating surface 164 of terminal block 160 lies flush against housing wall 162. Housing wall 162 may be substantially identical to housing wall 62 described above and has an exterior surface 161 facing outwardly and an interior surface 159 that faces the hermetically sealed interior space 193 defined by the housing and containing the motor/compressor subassembly 21. Although FIGS. 20-27 show the housing wall as having a substantially cylindrical shape, it should be understood that housing wall 162 may have alternative shapes. Accordingly, mating surface 164 can take other shapes to engage such alternatively shaped housings. Furthermore, the entirety of mating surface 164 need not be shaped to conform to the housing. Instead, mating surface 164 may be formed such that only an outer perimeter portion of mating

surface 164 is shaped to conform to the housing and contacts exterior surface 161 of housing wall 162 to sealingly encircle aperture 164.

[0068] Terminal block 160 is mounted on the exterior surface of housing wall 162 such that terminal block 160 is disposed entirely outside of exterior surface 161 of housing wall 162, as shown in FIG. 23. Terminal block 160 is hermetically sealed to exterior surface 161 of housing wall 162 by welding, brazing or the like around the perimeter of mating end 163. Because the hermetic seal between terminal block 160 and housing wall 162 is spaced radially outwardly of aperture 164 and not formed with the sidewalls of aperture 164, terminal block 160 and aperture 164 do not have to form a tight fit and, when manufacturing the housing, aperture 164 may be located and formed using relatively loose tolerances.

[0069] As illustrated in FIG. 25, terminal block 160 may also include annular groove 166, which is defined in perimetrical surface 167 of terminal block 160 and extends about the perimeter or circumference of terminal block 160. Perimetrical surface 167 may include frustoconical guide surface 168 adjacent groove 166. Guide surface 168 tapers inwardly moving from groove 166 to projecting end 165. In other words, guide surface 168 slopes from a first diameter  $D_3$  at projecting end 165 to a larger second diameter  $D_4$  adjacent groove 166. Both annular groove 166 and tapered guide surface 164 cooperate to receive a snap-fit protective cover, such as cover 190 illustrated in FIGS. 20, 21, 26 and 27.

[0070] Cylindrical cover 190 may be formed of a plastic such as polyurethane or other suitable material, and includes six, equally spaced-apart, resilient mounting members or legs 192. Each leg 192 includes a radially inwardly projecting tab or lip 194 that is shaped and sized to fit within annular groove 166. To install cover 190 on terminal block 160, resilient legs 192 are urged along tapered guide surface 164, causing resilient legs 192 to flex outward. When lip 194 reaches groove 164, resilient legs 192 spring inward, snapping lip 194 into groove 164, thereby locking cover 190 onto terminal block 160. The more distal edge surface of groove 166 forms latching surface 195 that engages lips 194 and prevents cover 190 from being removed from the terminal body without prying lips 194 radially outwardly to disengage lips 194 from groove 166.

[0071] When attached, cover 190 encloses the outwardly projecting ends 181 of the terminal pins. Cover 190 also includes a D-shaped hole 196 through which a wire assembly leading from the power source can extend. Cover 190 protects the terminal assembly from damage during operation and is relatively easy to install. Although cover 190 and terminal block 160 illustrated in FIGS. 20-27 both have a circular cross section where they are engaged, it should be understood that terminal block 160 and cover 190 can be any suitable shape, such as a generally rectangular shape.

[0072] Similar to metallic disk 66 shown in FIGS. 14-19, terminal block 160 shown in FIGS. 20-25 withstands both the heat of welding and the pressures created in a carbon dioxide compressor. Consequently, terminal block 160 provides a robust compressor assembly design. In the illustrated embodiments, pin assemblies 180 are mounted in holes 172 prior to mounting of the terminal block to housing wall 162,

however, if desired, it would also be possible to mount pin assemblies **180** in holes **172** after securing terminal block **160** on housing wall **162**.

[0073] While this invention has been described as having an exemplary design, the present invention may be further modified within the scope of this disclosure. This application is therefore intended to cover any variations, uses, or adaptations of the invention using its general principles. Further, this application is intended to cover such departures from the present disclosure as come within known or customary practice in the art to which this invention pertains.

What is claimed is:

1. An assembly for use with a hermetic compressor, said assembly comprising:

a hermetically sealed housing defining an interior space and including a housing wall with an interior surface and an exterior surface, said housing wall defining an aperture extending through said housing wall and communicating with said interior space;

a motor and a compressor mechanism operably coupled with said motor disposed within said interior space;

a terminal block mounted on said housing wall proximate said aperture and forming a hermetic seal with said exterior surface of said housing wall, said hermetic seal encircling said aperture; and

at least one terminal pin mounted in said terminal block and extending through said aperture.

2. The hermetic compressor assembly of claim 1 wherein said terminal block includes a mating surface flushly engaged with said exterior surface of said housing wall and encircling said aperture.

3. The hermetic compressor assembly of claim 2 wherein said exterior surface is cylindrical and said mating surface is a concave surface.

4. The hermetic compressor assembly of claim 1 wherein said at least one terminal pin comprises a terminal pin assembly threadingly engaging a threaded opening defined by said terminal block.

5. The hermetic compressor assembly of claim 1 wherein said at least one terminal pin has an outwardly projecting end and said assembly further comprises a cover securable to said terminal block wherein said cover defines an enclosure for said outwardly projecting end of said at least one terminal pin when said cover is secured to said terminal block and wherein said terminal block includes a latching surface securably engageable with said cover.

6. The hermetic compressor assembly of claim 5 wherein said latching surface is defined by a groove formed in said terminal block.

7. The hermetic compressor assembly of claim 5 wherein said cover includes at least one resilient mounting member engageable with said latching surface to secure said cover to said terminal block.

8. The hermetic compressor assembly of claim 7 wherein said at least one mounting member includes a radially inwardly extending tab engageable with said latching surface.

9. The hermetic compressor assembly of claim 7 wherein said terminal block includes a guide surface disposed between said latching surface and a distal end of said

terminal block, said guide surface tapering radially inwardly as said guide surface projects from said latching surface toward said distal end.

10. The assembly of claim 1 wherein said terminal block is disposed entirely outwardly of said exterior surface of said housing wall.

11. The assembly of claim 1 wherein said terminal block includes a portion disposed within said aperture.

12. The assembly of claim 1 wherein said terminal block is welded to said exterior surface of said housing wall.

13. A hermetic compressor assembly, said assembly comprising:

a hermetically sealed housing defining an interior space and including a housing wall with an interior surface and an exterior surface, said housing wall defining an aperture extending through the wall and in communication with said interior space;

a motor and a compressor mechanism operably coupled with said motor disposed within said interior space;

a terminal block mounted on said housing covering said aperture and forming a hermetic seal with said housing wall, said terminal block defining an annular groove;

at least one terminal pin extending through said terminal block and having an end projecting outwardly from said terminal block; and

a cover having a plurality of radially inwardly projecting tabs engageable with said groove to thereby mount said cover to said terminal block with said cover substantially enclosing said outwardly projecting end of said at least one terminal pin.

14. The hermetic compressor assembly of claim 13 wherein said cover includes a plurality of resilient mounting members extending therefrom and said tabs are disposed on respective distal ends of said plurality of resilient mounting members.

15. The hermetic compressor assembly of claim 13 wherein said terminal block includes a guide surface disposed between said annular groove and a distal end of said terminal block, said guide surface tapering radially inwardly as said guide surface projects from said latching surface to said distal end.

16. The hermetic compressor assembly of claim 15 wherein said guide surface forms a frustoconical shape.

17. A hermetic compressor assembly, said assembly comprising:

a hermetically sealed housing defining an interior space and including a housing wall having an interior surface and an exterior surface, said housing wall defining an aperture in communication with said interior space;

a motor and a compressor mechanism operably coupled with said motor disposed within said interior space;

a terminal block positioned over said aperture and welded to said exterior surface of said housing at a location spaced radially outwardly of said aperture; and

at least one terminal pin mounted in said terminal block and extending through said aperture.

18. The hermetic compressor assembly of claim 17 wherein said terminal block is disposed entirely outwardly of said exterior surface of said housing wall.

19. The hermetic compressor assembly of claim 17 wherein said terminal block includes a portion disposed within said aperture.

20. The hermetic compressor assembly of claim 17 wherein said terminal block forms a hermetic seal with said exterior surface of housing wall, said hermetic seal encircling said aperture.

21. The hermetic compressor assembly of claim 17 wherein said exterior surface of said housing wall has a cylindrical shape and said terminal block defines a concave surface flushly engageable with said exterior surface.

22. A method of assembling a hermetic compressor comprising:

providing a housing having a housing wall with an interior surface and an exterior surface;

forming an aperture in the housing wall;

installing at least one terminal pin in a terminal block;

mounting the terminal block on the housing wherein the terminal block covers the aperture; and

forming a hermetic seal between the terminal block and the exterior surface of the housing wall wherein said hermetic seal circumscribes the aperture.

23. The method of claim 22 wherein the steps of mounting the terminal block to the housing and forming the hermetic

seal between the terminal block and the exterior surface of the housing wall both comprise welding the terminal block to the exterior surface of the housing wall.

24. The method of claim 22 wherein the step of installing at least one terminal pin assembly in the terminal block includes threadingly engaging the at least one terminal pin assembly with the terminal block.

25. The method of claim 24 wherein the step of installing at least one terminal pin assembly in the terminal block is performed prior to mounting the terminal block on the housing.

26. The method of claim 24 wherein the step of installing at least one terminal pin assembly in the terminal block is performed after mounting the terminal block on the housing.

27. The method of claim 22 wherein the exterior surface of the housing wall has a cylindrical shape and said method further includes forming a concave mating surface on the terminal block wherein the mating surface is flushly engageable with the cylindrical exterior surface of the housing wall.

28. The method of claim 22 further comprising the step of forming a groove in the terminal block whereby a cover may be engaged with the groove to thereby secure the cover to the terminal block.

\* \* \* \* \*