

[54] ENGINE ROTATIONAL DIRECTION CONTROL

[75] Inventor: Edward E. Thomas, Galesburg, Ill.

[73] Assignee: Outboard Marine Corporation, Waukegan, Ill.

[22] Filed: Feb. 25, 1974

[21] Appl. No.: 445,081

Related U.S. Application Data

[63] Continuation of Ser. No. 260,288, June 6, 1972.

[52] U.S. Cl. 123/198 R, 123/198 D

[51] Int. Cl. F02b 77/00

[58] Field of Search 123/198 R, 198 D, 198 DB, 123/185 R, 185 S, 185 D, 142, 118, 179 A, 179 SE, 179 G, 186, 41, 65 R, 73 R

[56] References Cited

UNITED STATES PATENTS

891,368 6/1908 Potter 123/198 D

1,148,042	7/1915	Norrman.....	123/65 X
2,444,273	6/1948	Stevens.....	123/41 X
2,635,417	4/1953	Brooks.....	123/41 X
3,001,516	9/1961	Henninger.....	123/41 X
3,019,596	2/1962	Henninger.....	123/198 D X
3,065,285	11/1962	Martensson.....	123/198 R X
3,648,675	3/1972	Germander.....	123/41 X

Primary Examiner—Charles J. Myhre
 Assistant Examiner—Ronald Lazarus
 Attorney, Agent, or Firm—Michael, Best & Friedrich

[57] ABSTRACT

Disclosed herein is apparatus for controlling the direction of engine rotation comprising means connecting a shaft driven by the engine to the throttle valve for displacing the throttle valve to a closed position to prevent engine operation in response to shaft rotation in an unwanted direction.

16 Claims, 4 Drawing Figures

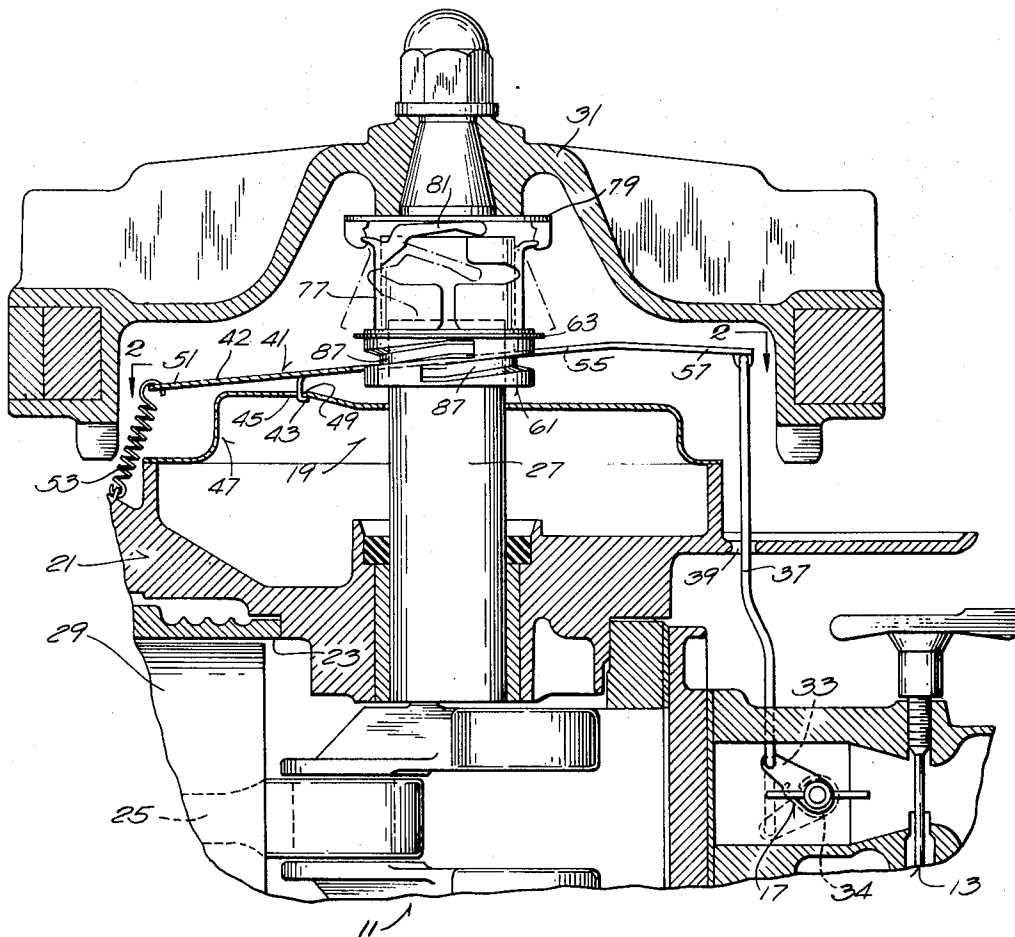

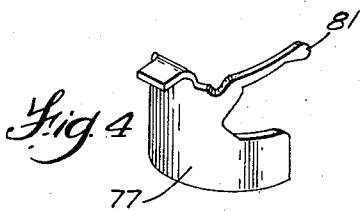
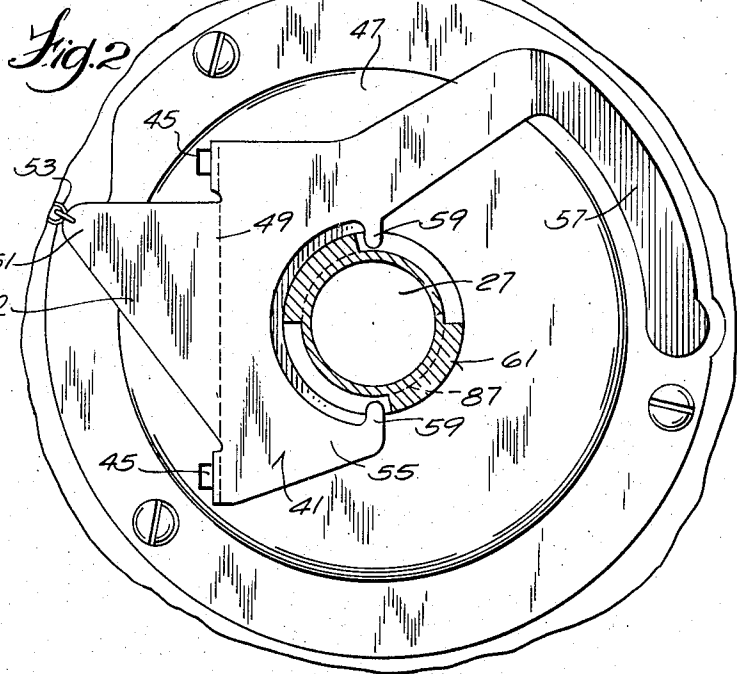
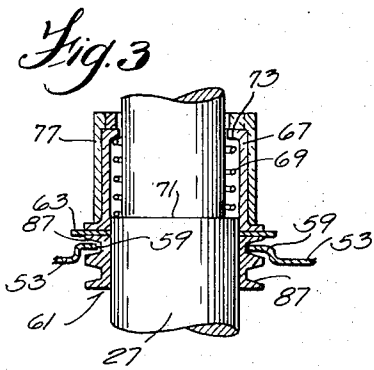
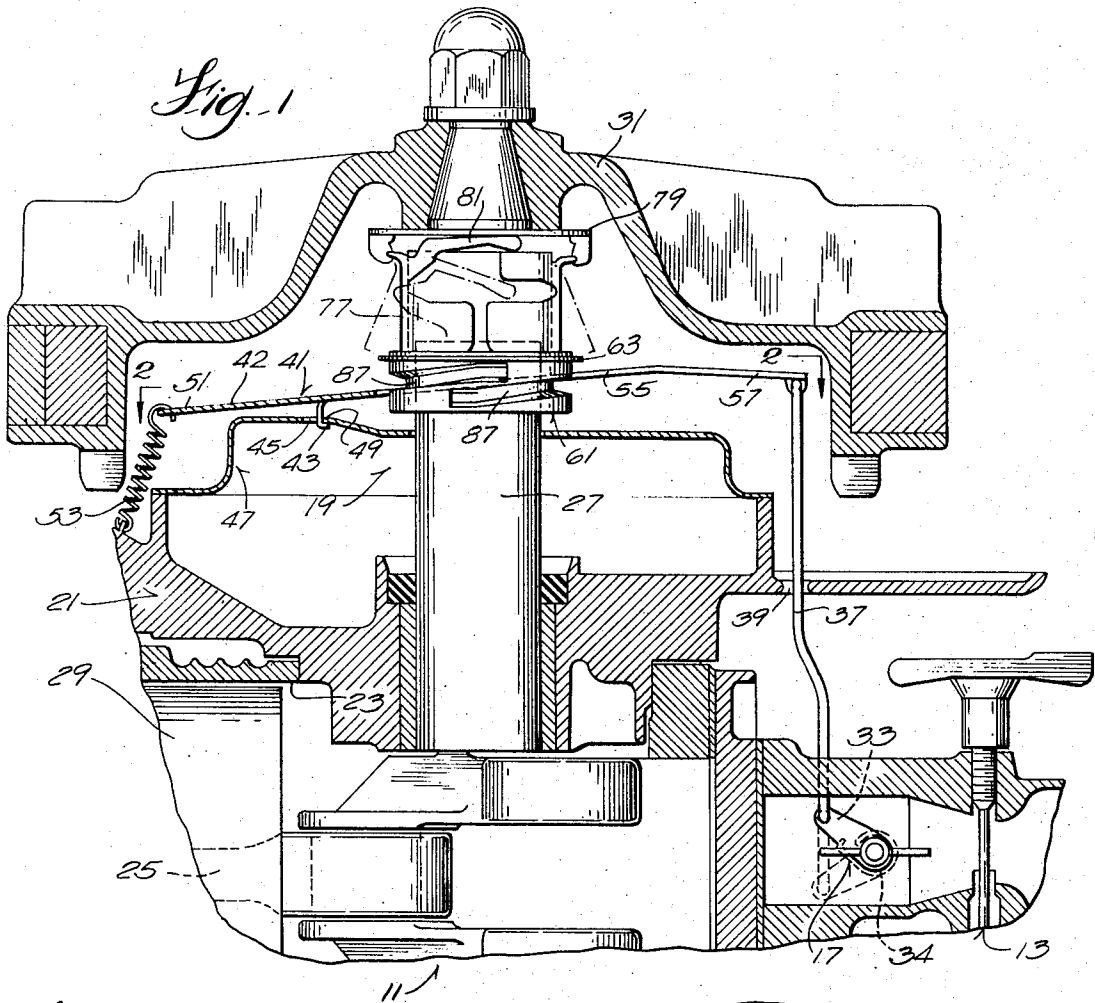

ENGINE ROTATIONAL DIRECTION CONTROL

This application is a continuation of my application Ser. No. 260,288 filed June 6, 1972.

BACKGROUND OF THE INVENTION

The invention relates generally to internal combustion engines including means for controlling engine speed and operation, such as for instance, a carburetor including a throttle valve. The invention also relates to engines having governor arrangements preventing engine operation above a preselected speed or speed range. Still more particularly, the invention relates to arrangements for preventing engine operation in an unwanted direction. One arrangement for preventing operation in an unwanted direction is disclosed in the Donohue et al. U.S. application Ser. No. 208,802 filed Dec. 16, 1971, now U.S. Pat. No. 3,795,235. Disclosed therein is an engine ignition system arranged to prevent engine operation in an unwanted direction.

SUMMARY OF THE INVENTION

The invention provides a mechanical linkage which is operative to prevent engine operation in response to attempted operation in one direction. More specifically, the invention provides mechanical means connecting a shaft driven by the engine to an engine speed controlling means for preventing engine operation in response to rotation of the shaft in one direction.

In accordance with one preferred form of the invention, the means for controlling engine operation comprises a carburetor including a throttle valve movable between opened and closed positions, together with means connecting the throttle valve to the shaft for displacing the throttle valve toward the closed position to prevent engine operation in response to rotation of the shaft in an undesired direction.

Still more specifically, in the preferred embodiment of the invention, the shaft is the engine crankshaft and the means for preventing engine operation comprises a push rod connected to the throttle valve and guided by the engine for throttle valve controlling movement, together with an arm mounted on the engine for movement relative to a position engaging the push rod so as to displace the throttle valve toward the closed position, and means connecting the arm to the crankshaft to displace the arm to the position displacing the throttle valve toward the closed position.

The means connecting the arm to the shaft comprises a collar which is mounted on the crankshaft for rotary movement relative thereto and which includes a slot having a portion inclined with respect to the axis of the shaft, together with means on the arm received in the slot so that, in response to initial crankshaft rotation in the undesired direction, the arm is cammed by the collar to the position displacing the push rod so as to displace the throttle valve toward the closed position and thereby prevent engine operation in the undesired direction.

Further in accordance with the invention, the arrangement for connecting the shaft to the throttle valve to prevent engine operation in response to rotation of the crankshaft in the undesired direction comprises modification of a previously existing governor arrangement. More specifically, such modification involves the elimination of a peripheral groove in a collar rotatably and axially mounted on the crankshaft and substitution

therefore in the collar of a cam slot which is inclined relative to the axis of the crankshaft and which receives a portion of the governor arm. Frictional resistance to rotary movement of the collar relative to the crankshaft causes initial rotary movement of the collar relative to the governor arm so as to displace the governor arm to the position which is effective to move the throttle toward the closed position in response to attempted engine operation in the undesired rotational direction.

One of the principal objects of the invention is the provision of an engine including a mechanical linkage preventing engine operation in an undesired rotational direction.

Another of the principal objects of the invention is the provision of a governor arrangement which is operative to displace a throttle valve toward the closed position in response to excessive engine speed and which is also operative to displace the throttle valve toward the closed position in response to attempted engine operation in an undesired rotational direction.

Other objects and advantages of the invention will become known by reference to the following description, claims, and accompanying drawings.

DRAWINGS

FIG. 1 is a fragmentary view, partially in section, of an engine embodying various of the features of the invention.

FIG. 2 is a fragmentary sectional view taken along line 2-2 of FIG. 1.

FIG. 3 is a fragmentary view of a portion of the mechanism included in FIG. 1.

FIG. 4 is a perspective view of one of the components of the mechanism shown in FIG. 1.

Before explaining the invention in detail, it is to be understood that the invention is not limited in its application to the details of construction and arrangement of parts set forth in the following general description or illustrated in the accompanying drawings, since the invention is capable of other embodiments and of being practiced or carried out in various ways. Also, it is to be understood that the phraseology or terminology employed herein is for the purpose of description and not of limitation.

GENERAL DESCRIPTION

Shown in the drawings is a two stroke internal combustion engine 11 which embodies various of the features of the invention and which includes means operable independently of engine operation for controlling engine speed, together with a governor 19 which is operatively connected to the engine speed controlling means to limit the operational speed of the engine 11. While various arrangements can be employed, in the illustrated construction, such engine speed controlling means comprises a carburetor 13 with a pivotally mounted throttle valve 17 movable between open and closed positions, together with means operable in response to engine operation at increasing speeds to displace the throttle valve 17 toward the closed position so as to thereby limit the operational speed of the engine 11.

More specifically, the engine 11 shown in the drawings includes an engine block 21 defining a cylinder 23 having an axis or centerline 25, together with a rotatably mounted output or crankshaft 27. Connected to the crankshaft 27 is a piston 29 operable in the cylinder

23. Mounted on the outer end of the crankshaft 27 is a flywheel 31.

The carburetor 13 further includes a throttle lever 33 which is fixed to the throttle valve 17 so that movement of the lever 33 causes movement of the throttle valve 17. In FIG. 1, the throttle lever 33 is shown in full lines in its open position and is shown in its closed position in dotted lines. Wound around a shaft connecting the throttle lever 33 to the throttle valve 17 is a torsion spring 34 which exerts a rotational force in a clockwise direction so as to displace the throttle valve 17 toward the open position.

Pivotaly connected to and extending from the throttle lever 33 is a push rod 37 which projects through an opening 39 in a web in the engine block 21 so as to guide push rod movement and so that the outer or free end of the push rod 37 is in position for engagement by the governor 19 to enable lengthwise displacement of the push rod 37 by the governor 19 to displace the throttle valve 17 toward its closed position.

The governor 19 includes a governor arm or plate 41 which is supported for pivotal movement relative to the engine block 21 by a pair of integrally extending mounting ears or tabs 43 which project into a pair of aligned openings or slots 45 provided in a thin mounting plate 47 supported by the engine block 21 and which are located in spaced relation from and on one side of the crankshaft 27. The governor arm or plate 41 also includes one portion or wing 42 which extends from the pivot axis 49, i.e., the line joining one edge of the slots 45, in the direction away from the crankshaft 27 and which includes a part 51 attached to one end of a coil spring 53 fixed, at its other end, to a part of the engine block 21 so as to bias the governor arm 41 for pivotal movement about its pivot axis 49 in the counterclockwise direction as shown in FIG. 1. If desired, the lower end of the spring 53 can be attached to a speed control lever movably mounted on the engine block 21 to facilitate changing the length of the spring 53 and thereby the bias or force exerted by the spring 53 so as to vary the governed speed of the engine.

The governor arm 41 also includes a second portion or wing 55 which extends from the pivotal mounting axis 49 in the other direction and which includes a leg 57 extending into position for engagement with the free or outer end of the push rod 37 at a location on the opposite side of the crankshaft 27 from the mounting ears 43. The second wing 55 also includes diametrically opposed and radially inwardly extending tabs 59 which are engaged with a collar 61 mounted on the crankshaft 27 inwardly of the flywheel 31 for axial and rotary movement relative to the crankshaft 27. However, because of friction, the collar 61 will normally tend to rotate with the crankshaft 27.

The collar 61 is displaceable axially inwardly toward the cylinder centerline 25 by an arrangement (See FIG. 3) including a thrust washer 63 which is engaged against the axially outer face of the collar 61 and which, in turn, engages a sleeve in the form of a spring cup 67 which is telescopically carried on the crankshaft 27. Means are provided for biasing the sleeve or spring cup away from the cylinder centerline 25. While various arrangements can be employed, in the illustrated construction, such means comprises a spring 69 which is located within the spring cup 67 and in encircling relation to the crankshaft 27 and which serves to bias the sleeve or spring cup 67 axially outwardly of the crank-

shaft. At its axially inner end, the spring 69 is seated against an annular shoulder 71 on the crankshaft 27 and, at its axially outward end, the spring 69 is seated against an intumed web or flange portion 73 of the spring cup 67.

The spring cup 67 is displaced axially inwardly of the crankshaft 27 toward the cylinder centerline 25 and against the action of the spring 69 in response to increasing engine speed by a pair of fly weights 77 which are pivotally mounted (See FIG. 1) on a drive plate 79 which is fixed to the crankshaft 27 for common rotary movement therewith and which is located between the spring cup 67 and the flywheel 31. The fly weights 77 each include arms or levers 81 which, as the fly weights 77 are extended radially in response to increasing engine speed, bear against the outer surface of the flange portion 73 of the spring cup 67 so as to axially inwardly displace the spring cup 67, against the action of the spring 69, toward the cylinder centerline 25. Such movement displaces the washer 63 and the collar 61 toward the cylinder centerline 25 and, due to engagement of the collar 61 with the tabs 59 of the governor arm 41, thereby serves to pivot the governor arm in the clockwise direction as seen in FIG. 1 about the mounting ears 43 so that the leg 57 depresses the push rod 37 to move the throttle valve 17 toward the closed position as engine speed advances.

The fore mentioned throttle valve spring 34 serves as an additional bias to the governor control mechanism in much the same manner as the springs 53 and 69. In addition, the throttle valve spring 34 serves to keep the push rod 37 in engagement with the leg 57 of the governor arm or plate 41. By prior selection of the springs 34, 53, and 69, engine operation above a preselected engine speed range can be reasonably accurately prevented.

As thus far disclosed, the construction is conventional and has been in use for more than at least one year prior to the filing date of this application.

In accordance with the invention, means are provided to prevent engine operation in one direction of rotation. While other constructions can be employed, in the illustrated construction, such means comprises a modification of the previously existing governor arrangement and more particularly a modification to the collar 61.

More specifically, in the prior construction, the collar was provided with an annular slot in which the governor tabs 59 were received and which was located in a plane extending perpendicularly to the crankshaft axis, to thereby permit unlimited rotary movement of the collar relative to the governor arm 41 without affecting the position of the governor arm. In accordance with the invention, the previous annular slot is no longer employed, and instead, there is provided a pair of diametrically opposed slots 87 each including a central portion which extends for about 180° and which advances axially as it extends circumferentially. Each slot also includes, at each end of the central portion, respective end portions which extend circumferentially for about 15° and in respectively spaced and parallel planes perpendicular to the crankshaft 27. The slots 87 are arranged so as to be diametrically symmetrical, i.e., the slots are identical to each other except for being on opposite sides of the collar 61.

The tabs 59 of the governor arm 41 extend into the slots 87 and thereby limit relative rotary movement be-

tween the governor arm and the collar to a range of about 200° (In the illustrated construction, the governor arm tabs 59 have a width equal to an arcuate extent of about 10°). Such limitation of relative rotation between the governor arm 41 and the collar 61 results in relative rotation between the collar 61 and the crankshaft 27 during engine operation.

More specifically with respect to operation, when the engine 11 is running in the desired rotary direction, the governor arm tabs 59 will be located in the respective slot end portions most remote from the cylinder centerline 25 and operation of the governor 19 will be essentially as before.

However, in the event that the engine attempts rotation in the opposite or undesired direction, the collar 61 will initially tend to rotate with the crankshaft 27 in the undesired direction, thereby rotating relative to the governor arm 41 and, because of the engagement of the governor arm tabs 59 in the slots 87, will cause the governor arm tabs 59 to move from the slot end portions most remote from the cylinder centerline 25 to the end portions closest to the cylinder centerline 25. Such axially inward displacement of the governor arm tabs 59 causes the governor arm 41 to pivot in the clockwise direction as seen in FIG. 1 about its mounting axis 49 so as thereby to displace the push rod 37 in the direction to close the throttle valve 17 and thereby prevent engine operation in the unwanted rotary direction.

When another attempt is made to start the engine and crankshaft rotation is initiated in the desired rotary direction, the governor arm tabs 59 will initially ride in the slots 87 to positions at the axially outer end portions of the slots 87 remote from the cylinder centerline 25, to thereby permit opening of the throttle valve 17 and normal engine and governor operation.

While the collar 61 has been shown on the crankshaft 21, it is within the invention to carry the collar on any shaft driven by the engine in accordance with engine speed.

Various of the features of the invention are set forth in the following claims.

I claim:

1. Apparatus for controlling the direction of engine rotation comprising an internal combustion engine, a shaft driven by said engine, a carburetor mounted on said engine and including a throttle valve movable between opened and closed positions, and means connecting said throttle valve to said shaft for displacing said throttle valve toward said closed position for preventing engine operation in response to rotation of said shaft in one direction.

2. An apparatus in accordance with claim 1 wherein said engine includes a crankshaft and said shaft is said crankshaft.

3. Apparatus in accordance with claim 1 wherein said means for preventing engine operation comprises a push rod connected to said throttle valve and guided for movement by said engine, an arm mounted on said engine for movement relative to a position engaging said push rod so as to displace said throttle valve toward said closed position, and means connecting said arm to said shaft to displace said arm to said position.

4. An apparatus in accordance with claim 3 wherein said means for connecting said arm to said shaft comprises a collar mounted on said shaft for rotary and axial movement relative thereto and including a slot

having a portion inclined with respect to the axis of said shaft and further including means on said arm received in said slot.

5. Apparatus in accordance with claim 4 and further including means biasing said arm in the direction counter to the direction which is effective to displace said throttle valve toward said closed position.

6. Apparatus in accordance with claim 5 wherein said engine includes a crankshaft and said shaft is said crankshaft, wherein said engine further includes a governor including said arm and said collar, wherein said arm is pivotally mounted on said engine on one side of said crankshaft, wherein said push rod is mounted on the other side of said crankshaft, and wherein means are provided for displacing said collar axially of said crankshaft in the direction which is effective to displace said arm so as to displace said throttle valve toward said closed position in response to increasing engine speed.

7. Apparatus in accordance with claim 6 wherein said means for axially displacing said collar in response to increasing engine speed comprises a sleeve telescopically carried on said crankshaft, means biasing said sleeve away from said collar, and fly weight means movably carried by said shaft and operatively engageable with said sleeve to displace said sleeve against the action of said biasing means so as to displace said collar in the direction which is effective to displace said arm so as to displace said throttle valve toward said closed position.

8. Apparatus for controlling the direction of engine rotation comprising an internal combustion engine including a crankshaft, a carburetor mounted on said engine and including a throttle valve movable between opened and closed position, a push rod connected to said throttle valve and guided for movement by said engine, an arm mounted on said engine for movement relative to a position engaging said push rod so as to displace said throttle valve toward said closed position, a collar mounted on said crankshaft for rotary and axial movement relative thereto and including a slot having a portion inclined with respect to the axis of said crankshaft, and means on said arm received in said slot, whereby said arm is moved to said position displacing said throttle valve toward said closed position in response to rotation of said crankshaft in one direction.

9. Apparatus for controlling the direction of engine rotation comprising an internal combustion engine, a shaft driven by said engine, a carburetor mounted on said engine and including a valve movable between opened and closed positions, and means connecting said valve to said shaft for displacing said valve toward said closed position for preventing engine operation in response to rotation of said shaft in one direction.

10. An apparatus in accordance with claim 9 wherein said engine includes a crankshaft and said shaft is said crankshaft.

11. Apparatus in accordance with claim 9 wherein said means for preventing engine operation comprises a push rod connected to said valve and guided for movement by said engine, an arm mounted on said engine for movement relative to a position engaging said push rod so as to displace said valve toward said closed position, and means connecting said arm to said shaft to displace said arm to said position.

12. An apparatus in accordance with claim 11 wherein said means for connecting said arm to said shaft comprises a collar mounted on said shaft for rotary and axial movement relative thereto and including a slot having a portion inclined with respect to the axis of said shaft and further including means on said arm received in said slot.

13. Apparatus in accordance with claim 12 and further including means biasing said arm in the direction counter to the direction which is effective to displace said valve toward said closed position.

14. Apparatus in accordance with claim 13 wherein said engine includes a crankshaft and said shaft is said crankshaft, wherein said engine further includes a governor including said arm and said collar, wherein said arm is pivotally mounted on said engine on one side of said crankshaft, wherein said push rod is mounted on the other side of said crankshaft, and wherein means are provided for displacing said collar axially of said crankshaft in the direction which is effective to displace said arm so as to displace said valve toward said closed position in response to increasing engine speed.

15. Apparatus in accordance with claim 14 wherein said means for axially displacing said collar in response to increasing engine speed comprises a sleeve telescop-

ically carried on said crankshaft, means biasing said sleeve away from said collar, and fly weight means movably carried by said shaft and operatively engageable with said sleeve to displace said sleeve against the action of said biasing means so as to displace said collar in the direction which is effective to displace said arm so as to displace said valve toward said closed position.

16. Apparatus for controlling the direction of engine rotation comprising an internal combustion engine including a crankshaft, a carburetor mounted on said engine and including a valve movable between opened and closed position, a push rod connected to said valve and guided for movement by said engine, an arm mounted on said engine for movement relative to a position engaging said push rod so as to displace said valve toward said closed position, a collar mounted on said crankshaft for rotary and axial movement relative thereto and including a slot having a portion inclined with respect to the axis of said crankshaft, and means on said arm received in said slot, whereby said arm is moved to said position displacing said valve toward said closed position in response to rotation of said crankshaft in one direction.

* * * * *

30

35

40

45

50

55

60

65