

Southwick & Barker,

Lock Nut.

No. 101674.

Patented Apr. 5. 1870.

Figure 1.

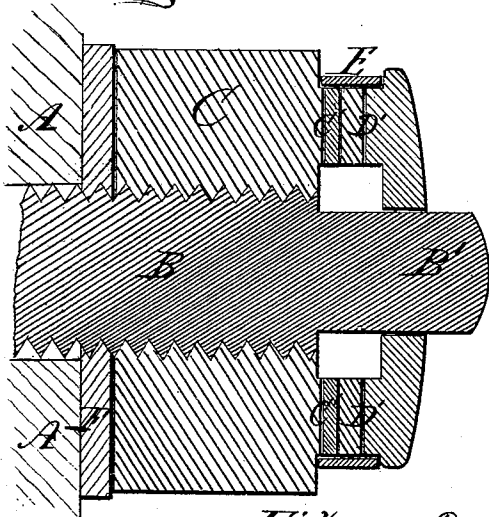

Figure 3.

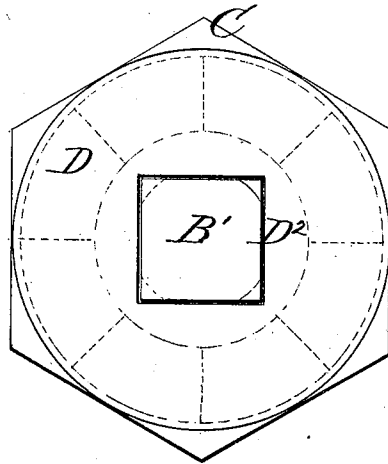

Figure 2.

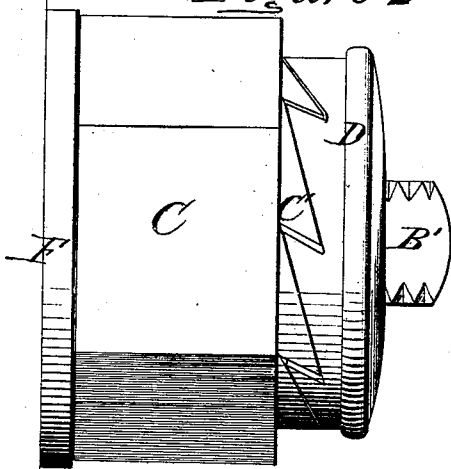

Figure 4.

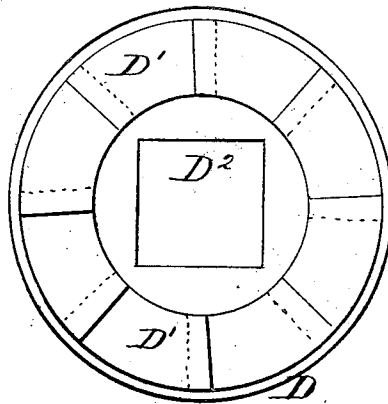
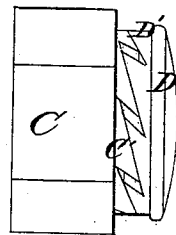

Figure 5.



Witnesses.
J. M. Campbell
R. V. Campbell

Inventors.
C. S. Southwick
D. H. Barker
Mason Fenwick Lawrence

United States Patent Office.

CHRISTOPHER S. SOUTHWICK AND DAVID H. BARKER, OF NEWPORT,
RHODE ISLAND.

Letters Patent No. 101,674, dated April 5, 1870.

IMPROVEMENT IN NUT-LOCK.

The Schedule referred to in these Letters Patent and making part of the same.

To all whom it may concern:

Be it known that we, CHRISTOPHER S. SOUTHWICK and DAVID H. BARKER, of Newport, in the county of Newport and State of Rhode Island, have invented a new and useful Improvement in Lock-Nuts for Screw-Bolts; and we do hereby declare that the following is a full, clear, and exact description of the same, reference being had to the accompanying drawing forming part of this specification, in which—

Figure 1 is a central section of our improved nut-locking plate and screw, as the same appear when applied or in use.

Figure 2 is a side elevation of the same.

Figure 3 is a front or end view of the same.

Figure 4 is an elevation of the inner face of the ratchet-locking plate.

Figure 5 is a diagram for illustrating the position of the locking-plate upon the ratchet-teeth of the nut, just before the retraction or turning back of the nut takes place.

Similar letters of reference in the several figures indicate like parts.

The nature of our invention consists in a nut with one or more ratchet-teeth on its upper or outer flat face, in combination with a centrally-perforated locking-plate, having a conversely-set ratchet-tooth or teeth on its under or inner face, the said ratchet-tooth or teeth which we adopt, and which are necessary to be used in carrying out our invention, being of such a form that those of the nut will become interlocked with those of the plate by a slight retraction of the nut after it has been forced home, and, when thus interlocked, will prevent any movement of the plate away from the nut in a direction lengthwise with the screw on which the nut and plate are applied.

To enable others skilled in the art to make and use our invention, we will proceed to describe the same.

In the accompanying drawing—

A is intended to represent one part of a structure, which is to be bolted firmly to another part.

B B', the screw-bolt;

C C', the nut;

D D' D², the locking-plate;

E, a finishing-ring; and

F, the usual washer.

The stem B' of the screw-bolt is made with four flat sides, as shown, and the central perforation D² in the locking-plate or cap is made with similar flat sides, so that, when the plate or cap is placed on the stem, it cannot turn independently of the screw.

The ratchet-teeth C' on the outer end of the nut are constructed so as to overlap or overhang one another to a slight degree, as shown in figs. 2 and 5, and the ratchet-teeth D' of the cap are similarly con-

structed, but, of course, are set to run conversely to those of the nut.

The ring E is fitted around the ratchets C' D'; so as to hide them from view. It may or may not be used, just as fancy dictates, as its design is merely ornamental, or to give a finishing appearance.

It is plain from the foregoing, in connection with the drawing, that if the nut C C' is screwed home, as shown in fig. 1, and the cap passed over the square stem of the screw, the ratchet-teeth will occupy the relation to one another shown in fig. 5.

Now, by slightly turning back the nut, the ratchets will interlock one with another, as shown in fig. 2, and when thus interlocked, no outward longitudinal movement of the locking-plate can take place, and, as this plate cannot turn on its stem, there will be no chance for the nut to unscrew and become detached.

It might be supposed that the slight turning back of the nut, in order to interlock the ratchets, would be objectionable; but, when it is considered that there is always more or less elasticity in the parts of structures which are screwed together, and that, therefore, the nut may be crowded up a little, and then, after the cap is fitted to its place, their bind relaxed by turning back the nut, no serious inconvenience will be experienced therefrom, but, on the contrary, the slight turning back of nuts after they have been crowded home, every good mechanic knows, is regarded as a great relief to machinery, especially on structures where there is the least jar brought to bear upon them.

In practice, the nuts and plates may be made of wrought metal, and then have the ratchets attached to them, or the nuts and plates may be cast with the ratchets upon them.

We prefer to use, as the same is the most practical and effective, a screw with four or more flat sides on its stem, but it is obvious that a feather formed on one side of the stem, or a stem with one flat side, would answer for keeping the locking-plate from turning. In either case the central perforation in the locking-plate must match the formation of the stem.

We discard as objectionable all keys or feathers made independent from the screw and locking-plate.

What we claim as our invention, and desire to secure by Letters Patent, is—

The lock-plate and nut, constructed substantially as described, with interlocking projections, whereby nuts are prevented from moving longitudinally after they are locked, substantially in the manner set forth.

CHRIS. S. SOUTHWICK. [L. S.]
DAVID H. BARKER. [L. S.]

Witnesses:

SAML. BROWN,
DANL. P. BULL.