

(No Model.)

2 Sheets—Sheet 1.

A. B. WATSON.
CAR FENDER.

No. 545,142.

Patented Aug. 27, 1895.

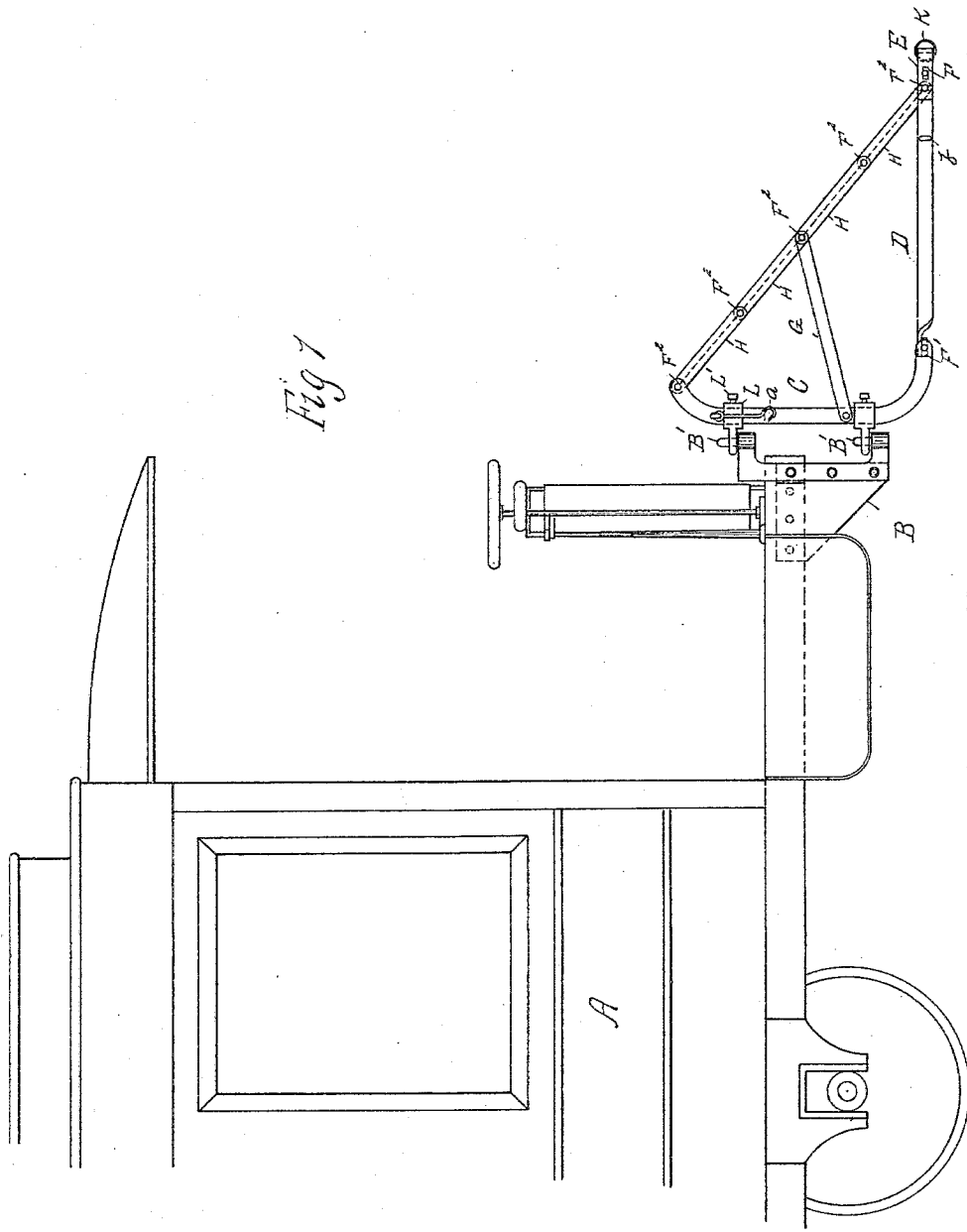

Witnesses
Robert J. Chipman
Am. M. Stew.

Inventor
Alfred B. Watson
By John F. Kerr
att'y

A. B. WATSON.
CAR FENDER.

No. 545,142.

Patented Aug. 27, 1895.

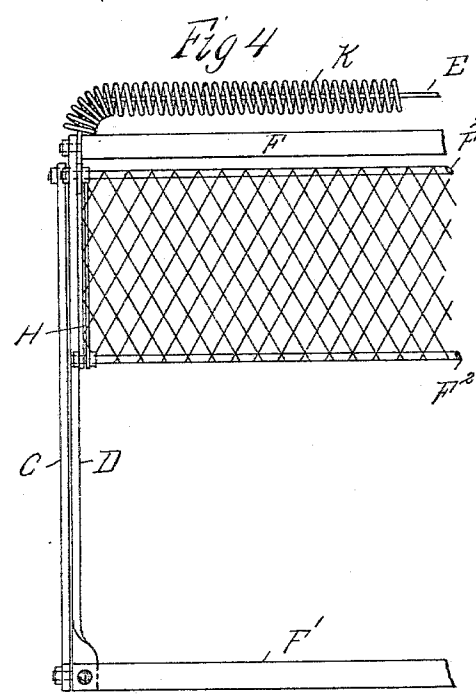
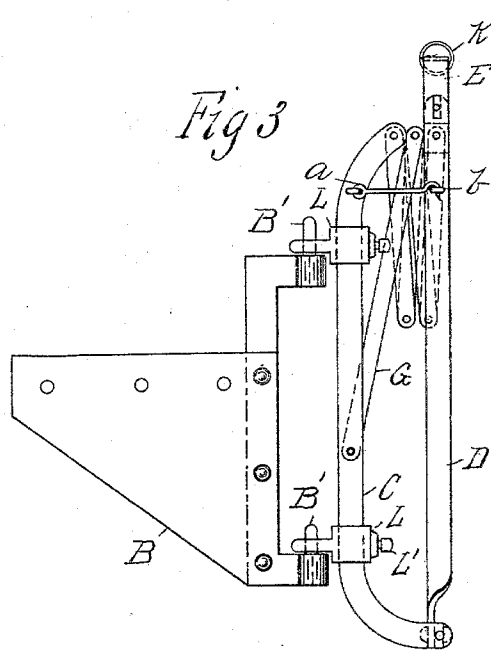
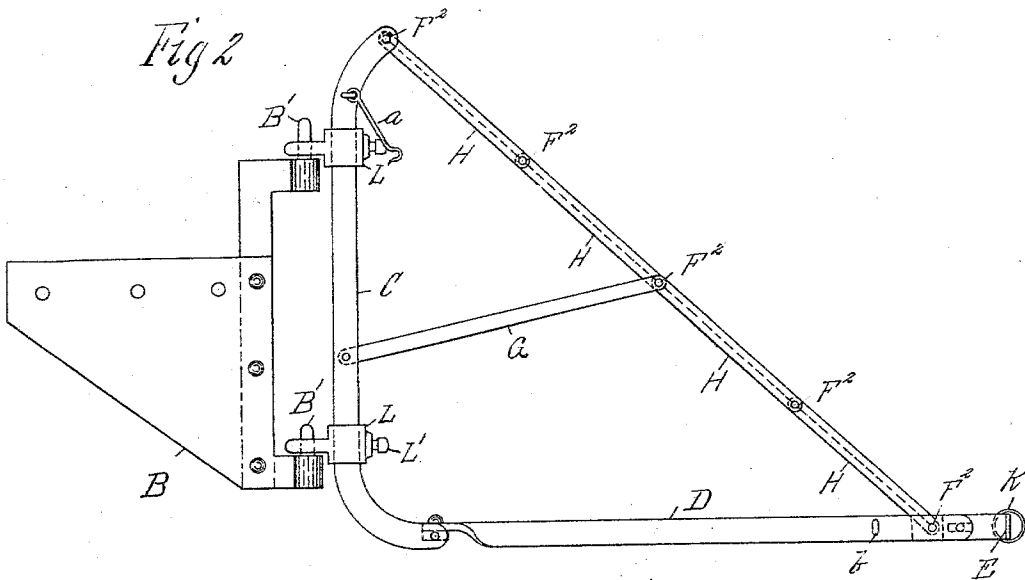

Witnesses
Robert J. Chipman
Amos Drew

Inventor
Alfred B. Watson
 By *John T. Keary*
 atty-

UNITED STATES PATENT OFFICE.

ALFRED B. WATSON, OF PATERSON, NEW JERSEY.

CAR-FENDER.

SPECIFICATION forming part of Letters Patent No. 545,142, dated August 27, 1895.

Application filed May 24, 1895. Serial No. 550,584. (No model.)

To all whom it may concern:

Be it known that I, ALFRED B. WATSON, of the city of Paterson, in the county of Passaic and State of New Jersey, have invented a certain new and useful Improvement in Car-Fenders, of which the following is a specification.

This invention relates to an improvement in car-fenders, and particularly to those used on trolley-cars or cars impelled by the use of electricity.

The object of my invention is to provide a fender that may be easily attached to or detached from any car, or removed from one end of the car to the other, or that may be opened or shut by lowering or raising the same, and that will be adapted to fold in closing, so as to take up but very little room and not interfere with the bumper, headlight of car, or the coupling of two cars.

A further object of my invention is to produce a fender possessing all the requisites above named, and also being simple in construction, durable, cheap, easily operated, and quickly repaired.

I accomplish these objects by my invention, which consists in the special features of construction and the combination or arrangement of parts hereinafter described and claimed, and shown in the accompanying drawings, which form a part of this specification, and in which—

Figure 1 is a side elevation of my improved fender attached to the forward end of a car. Fig. 2 is a side elevation of my improved fender enlarged. Fig. 3 is a side elevation of my improved fender, showing the same closed and hooked up so as not to interfere with the bumper, coupler, or headlight; and Fig. 4 is a front elevation showing fender when folded up or closed, as in Fig. 3, parts being broken away or omitted.

In the drawings, A represents a car; B, the hanger, which is provided with hinge-pins B' and B'.

I do not confine myself to the construction of a hanger as shown in the drawings, as any hanger provided with the hinge-pins B' B' will answer the purpose without departing from the spirit of my invention.

My improved fender consists of bars of suitable material, but preferably of wrought or

malleable iron, all joined or connected, as shown in the drawings, the front bar being provided with a cushion consisting of spiral coverings of wire or other suitable material with nettings stretched across the front of the frame. The netting may consist of any suitable material, but preferably of galvanized-iron netting.

The framework of my fender consists of the two upright back bars, which are suitably bent or curved at their extremities, if desired, as indicated in the drawings by C, the two side bars D, the front bar E, cross-bars F F' F² F² F² F², and the pivotal braces G. The bar F' is provided with a tang or tongue at each end, which passes through openings in the lower ends of the back uprights C and is secured therein by nuts, so as to permit the bar F' to turn as a hinge. The side bars D are secured to the cross-bar F' near the lower ends of the back uprights C, as shown in the drawings, and are adapted to be raised up and fastened by hook *a* and eye *b*, as shown in Fig. 3. The netting is put on in sections, as shown in Figs. 2 and 4, the cross-bars F² F² F² F² being round bars around which the netting is wrapped, twisted, or passed to permit the various sections of the front of the fender to be folded, as shown in Figs. 3 and 4. The front top side bars H H H H are secured on the ends of the bars F² F² F² F² by means of nuts, so as to permit the folding above mentioned. The fender may be provided with as many of these folding sections as are necessary.

I prefer to make my fender of four folding sections of such a length that when the fender is folded there is a clear opening beneath the folded netting for the bumper and coupler, as is apparent in Figs. 3 and 4.

To prevent the folding sections from sagging or folding downward, I provide the two side braces G, one end of which is pivotally secured to the back upright C and the other end to the central cross-bar F².

When the fender is open and extended, as shown in Fig. 2, the operation of closing is as follows: The side bars D are lifted up to perpendicular position shown in Fig. 3, the braces G assume an almost perpendicular position, carrying the central cross-bar to its top end,

the two intermediate cross-bars F² F² falling or being lowered causing the sections to fold and assume the position shown in Figs. 3 and 4.

5 The cross-bar F is a brace for strengthening purposes, serving to secure the bar or toe-pieces E and helping to form a platform in front of the netting.

To minimize the injury apt to be done by striking a person, I cover the front bar or toe-piece E with a cushion consisting of a spiral covering K, of wire or other suitable material.

10 As it is frequently necessary to change the position of the fender by raising or lowering it to suit the height of the car or for other purposes, I have provided the sliding supports L, which surround the back upright bars C and grip the bars by means of set-screws L', said sliding supports being provided with a tongue or extension with suitable holes adapted to fit snugly around the hinge-pins B'.

It frequently occurs, in the case of cars going through tunnels or passing each other on a curve on adjoining tracks, that the extended fenders collide, and my fender is so easily raised and lowered that it will not be necessary to remove the fenders in order to avoid collision in going around a curve or the striking of columns of masonry while in transit, as the mortorman may easily, with a hook which he carries, lift up the fender temporarily until the point of danger is passed, when it can be as easily lowered again.

Another advantage which I claim for my fender is that when it is lowered there is no danger of a person being picked up and struck by the bumper or coupler, as both are covered by netting.

With this description of my invention, what I claim, and desire to secure by Letters Patent, is—

40 1. A fender consisting of back uprights with front and side bars hinged to the lower ends of said uprights, in combination with sections of netting connecting to the upper ends of said uprights and the front portion of

said side bars, and braces pivotally connecting said uprights to the central portion of the net work, all constructed substantially as shown and described and for the purposes specified.

2. In combination with a railway car, a fender consisting of back uprights, a front bar and side bars hinged to the lower ends of said uprights, a cushion surrounding said front bar consisting of a spiral covering of any suitable material, a net work frame extending from the top ends of said uprights to the front portion or outer ends of the side bars consisting of sections adapted to fold when the side bars are raised and netting secured to each of said folding sections, and braces pivotally connecting the central folding point of the net work frame and the uprights, substantially as shown and described.

3. A railway car, hangers, provided with upright pins, secured to said car in combination with a fender consisting of back uprights, sliding supports through which said back uprights pass, set screws to secure said back uprights where desired in said supports, said supports provided with a lug having a hole adapted to fit around the upright pins on said hangers, a front bar and side bars secured to a cross bar the ends of said cross bar passing through the lower ends of said back uprights and secured so as to turn therein, a cushion surrounding said front bar and consisting of a spiral covering of any suitable material, a folding net work frame connecting the upper end of said back uprights and the front or outer portions of said side bars, net work secured on said folding sections and braces connecting said back bars and the sides of the folding net work frame midway between the ends thereof, all constructed substantially as shown and described.

ALFRED B. WATSON.

Witnesses:

WM. M. DREW,
LOUIS MICHEL.