

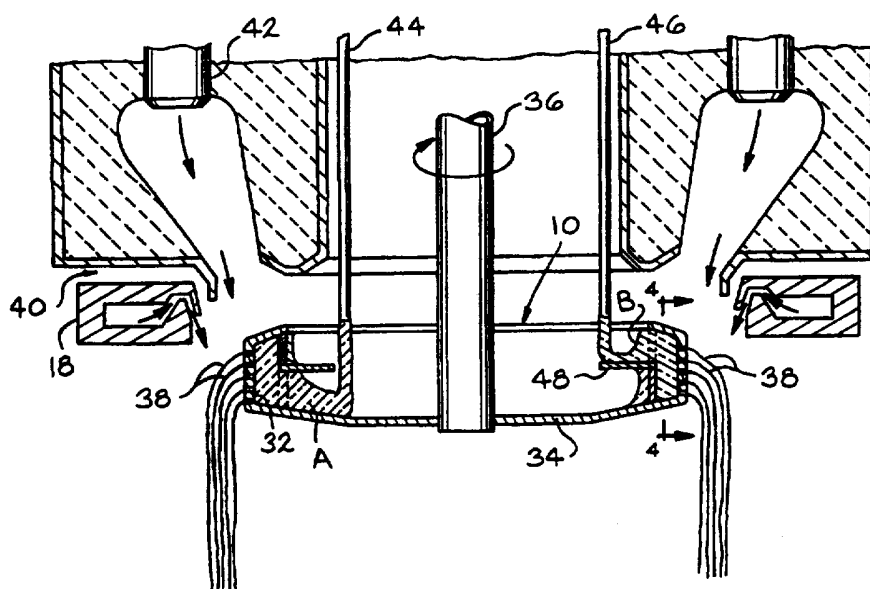

## INTERNATIONAL APPLICATION PUBLISHED UNDER THE PATENT COOPERATION TREATY (PCT)

<p>(51) International Patent Classification <sup>6</sup> : C03B 37/04, 37/075</p>	<p>A1</p>	<p>(11) International Publication Number: <b>WO 97/33841</b> (43) International Publication Date: 18 September 1997 (18.09.97)</p>
<p>(21) International Application Number: PCT/US97/03012 (22) International Filing Date: 27 February 1997 (27.02.97) (30) Priority Data: 08/608,872 29 February 1996 (29.02.96) US (71) Applicant: OWENS CORNING [US/US]; One Owens Corning Parkway, Toledo, OH 43659 (US). (72) Inventors: HOUSTON, Robert, L.; 1485 Londondale Parkway, Newark, OH 43055 (US). RAPP, Charles, F.; 1648 Golden Drive, Newark, OH 43055 (US). PELLEGRIN, Michael, T.; 505 Marion Manor Woods, Newark, OH 43055 (US). LOFTUS, James, E.; 1239 Normandy Drive, Newark, OH 43055 (US). AUBOURG, Patrick, F.; 526 West College Street, Granville, OH 43023 (US). (74) Agents: BRUESKE, Curtis, B. et al.; Owens Corning Science &amp; Technology Center, Building 54-1, 2790 Columbus Road, Granville, OH 43023-1200 (US).</p>	<p>(81) Designated States: AU, CA, CN, JP, KR, MX, NZ, European patent (AT, BE, CH, DE, DK, ES, FI, FR, GB, GR, IE, IT, LU, MC, NL, PT, SE). <b>Published</b> <i>With international search report. Before the expiration of the time limit for amending the claims and to be republished in the event of the receipt of amendments.</i></p>	

(54) Title: BICOMPONENT GLASS AND POLYMER FIBERS MADE BY ROTARY PROCESS



## (57) Abstract

In a method for making bicomponent glass and polymer fibers, molten glass (A, 90, 99) and molten polymer (B, 92, 97, 98) are supplied to a rotating spinner (10, 72) having an orificed peripheral wall (32, 66, 74). The molten glass and molten polymer are centrifuged through the orifices (56, 70, 84) as molten bicomponent glass and polymer streams. Then the streams are cooled to make bicomponent glass and polymer fibers.

**FOR THE PURPOSES OF INFORMATION ONLY**

Codes used to identify States party to the PCT on the front pages of pamphlets publishing international applications under the PCT.

AM	Armenia	GB	United Kingdom	MW	Malawi
AT	Austria	GE	Georgia	MX	Mexico
AU	Australia	GN	Guinea	NE	Niger
BB	Barbados	GR	Greece	NL	Netherlands
BE	Belgium	HU	Hungary	NO	Norway
BF	Burkina Faso	IE	Ireland	NZ	New Zealand
BG	Bulgaria	IT	Italy	PL	Poland
BJ	Benin	JP	Japan	PT	Portugal
BR	Brazil	KE	Kenya	RO	Romania
BY	Belarus	KG	Kyrgystan	RU	Russian Federation
CA	Canada	KP	Democratic People's Republic of Korea	SD	Sudan
CF	Central African Republic	KR	Republic of Korea	SE	Sweden
CG	Congo	KZ	Kazakhstan	SG	Singapore
CH	Switzerland	LI	Liechtenstein	SI	Slovenia
CI	Côte d'Ivoire	LK	Sri Lanka	SK	Slovakia
CM	Cameroon	LR	Liberia	SN	Senegal
CN	China	LT	Lithuania	SZ	Swaziland
CS	Czechoslovakia	LU	Luxembourg	TD	Chad
CZ	Czech Republic	LV	Latvia	TG	Togo
DE	Germany	MC	Monaco	TJ	Tajikistan
DK	Denmark	MD	Republic of Moldova	TT	Trinidad and Tobago
EE	Estonia	MG	Madagascar	UA	Ukraine
ES	Spain	ML	Mali	UG	Uganda
FI	Finland	MN	Mongolia	US	United States of America
FR	France	MR	Mauritania	UZ	Uzbekistan
GA	Gabon			VN	Viet Nam

BICOMPONENT GLASS AND POLYMER FIBERS  
MADE BY ROTARY PROCESS

TECHNICAL FIELD

5 This invention relates in general to the manufacture of fibers, and specifically to a method for manufacturing bicomponent glass and polymer fibers by a modified rotary process.

BACKGROUND

Bicomponent polymer fibers have previously been made by a textile  
10 process for use in products such as fabrics and hosiery. In this process, two molten polymers are supplied to a stationary spinneret having holes from which fibers are pulled or drawn. The polymers are usually combined to form fibers having a core of one polymer and a surrounding sheath of the other polymer.

The textile process usually makes relatively large diameter bicomponent  
15 fibers. For certain applications, there are advantages to using smaller diameter fibers. Also, the textile process is limited to the use of components having similar melting points, so that the lower melting component does not thermally degrade when exposed to the higher melting component.

Bicomponent glass fibers have been made by a modified rotary process.  
20 Two different types of molten glass are supplied to a rotating spinner having an orificed peripheral wall. The two types of molten glass are centrifuged through the orifices to form bicomponent glass fibers. The fibers are particularly useful in insulation products.

The manufacture of glass fibers is a different field from the manufacture of  
25 polymer fibers. The two materials have different physical properties such as different viscosities, and usually the softening point of the glass is different from the melting point of the polymer. The technologies for making the fibers are also different.

It has not previously been known to produce bicomponent fibers by  
combining glass and polymers. Such fibers would provide advantages associated with  
both bicomponent glass fibers and bicomponent polymer fibers, and would have  
30 properties and uses not provided by either fiber. Accordingly, it would be desirable to provide a process for making bicomponent glass and polymer fibers.

DISCLOSURE OF INVENTION

This invention relates to a method for making multicomponent fibers, and particularly bicomponent fibers. The bicomponent fibers are formed from glass and a thermoplastic material, preferably a polymer. In the method, molten glass and molten  
5 thermoplastic material are supplied to a rotating spinner having an orificed peripheral wall. Preferably the temperature at which the glass viscosity is 1000 poise is from about 200°C to about 495°C, and the melting point of the thermoplastic material is from about 200°C to about 345°C. The coefficient of thermal expansion of the thermoplastic material is preferably higher than that of the glass by an amount greater than about 10  
10 ppm/°C. The molten glass and molten thermoplastic material are centrifuged through the orifices as molten bicomponent streams of glass and thermoplastic material. Then the streams are cooled to make bicomponent fibers of glass and thermoplastic material.

The bicomponent fibers of glass and thermoplastic material produced by the method are novel and provide advantages associated with both bicomponent glass  
15 fibers and bicomponent polymer fibers. They also have properties and uses not provided by either of the previously known fibers.

BRIEF DESCRIPTION OF DRAWINGS

Fig. 1 is a schematic view in elevation of apparatus for carrying out the rotary method of the invention for making bicomponent fibers of glass and polymer.

20 Fig. 2 is a cross-sectional view in elevation of a spinner by which bicomponent fibers of glass and polymer can be produced according to the invention.

Fig. 3 is a schematic view in perspective of a portion of the spinner of Fig. 2.

Fig. 4 is a schematic view in elevation of the spinner of Fig. 2, taken along  
25 line 4-4 of Fig. 2.

Fig. 5 is a plan view of a portion of a second embodiment of a spinner for making bicomponent fibers of glass and polymer.

Fig. 6 is a cross-sectional view in elevation of a third embodiment of a spinner for making bicomponent fibers of glass and polymer.

30 Fig. 7 is a cross-sectional view in elevation of the orifice of the spinner of Fig. 6.

Fig. 8 is a schematic cross-sectional view of a bicomponent fiber of glass and polymer produced according to the invention.

Fig. 9 is a schematic cross-sectional view of a bicomponent fiber of glass and polymer in which differing viscosities of the glass and polymer enables the lower viscosity polymer to flow partially around the higher viscosity glass.

Fig. 10 is a schematic cross-sectional view of a bicomponent fiber of glass and polymer in which the differing viscosities enables the lower viscosity polymer to nearly enclose the higher viscosity glass.

Fig. 11 is a schematic cross-sectional view of a bicomponent fiber of glass and polymer in which the lower viscosity polymer flows all the way around the higher viscosity glass to enclose the glass and form a cladding.

Fig. 12 is a schematic cross-sectional view of a tricomponent fiber formed of glass and two different polymers.

#### BEST MODE FOR CARRYING OUT THE INVENTION

Fig. 1 illustrates a rotary fiber forming process for making insulation products from bicomponent fibers of glass and polymer in accordance with this invention. It is understood, however, that different fabrication processes can be used with the fibers to make textiles, filtration products, and other products. Such processes include stitching, needling, hydro-entanglement, and encapsulation. It is also understood that multicomponent fibers other than bicomponent fibers are included in the invention, and that the fibers can be formed from other thermoplastic materials such as asphalt in addition to polymers.

In the illustrated process, molten glass and molten polymer are supplied to spinners 10. The molten glass is supplied from any suitable source such as furnace 11 and forehearth 13. The molten polymer is supplied from any suitable source. For example, hopper 12 containing polymer granules can be connected to extruder 14 where the polymer is melted and then supplied to the spinners. As will be described below, the spinners produce veils 16 of bicomponent fibers of glass and polymer. The fibers are directed downwardly by any means, such as by annular blower 18. As the fibers are blown downwardly, they are attenuated and cooled. The fibers are collected as a wool pack 20 on any suitable surface, such as conveyor 22. A partial vacuum, not shown, can be positioned beneath the conveyor to facilitate fiber collection.

The wool pack of bicomponent fibers of glass and polymer may then optionally be passed through a station for further processing, such as oven 24. While passing through the oven, the wool pack is preferably shaped by top conveyor 26 and bottom conveyor 28, and by edge guides (not shown). The wool pack exits the oven as  
5 insulation product 30.

As shown in Fig. 2, each spinner 10 includes a peripheral wall 32 and a bottom wall 34. The spinner is rotated on any suitable means, such as spindle 36, as is known in the art. The rotation of the spinner centrifuges molten glass and molten polymer through orifices in the peripheral wall to form bicomponent fibers 38 of glass  
10 and polymer, in a manner described in greater detail below. The spinner preferably rotates at a speed from about 1200 rpm to about 3000 rpm. Spinners of various diameters can be used, and the rotation rates adjusted to give the desired radial acceleration at the inner surface of the peripheral wall. The spinner diameter is preferably from about 20 centimeters to about 100 centimeters. The radial acceleration ( $\text{velocity}^2/\text{radius}$ ) at the  
15 inner surface of the peripheral wall is preferably from about 4,500 meters/second<sup>2</sup> to about 14,000 meters/second<sup>2</sup>, and more preferably from about 6,000 meters/second<sup>2</sup> to about 9,000 meters/second<sup>2</sup>.

Annular blower 18 is positioned to direct the fibers downwardly for collection on the conveyor as shown in Fig. 1. Optionally the annular blower can use  
20 induced air 40 to further attenuate the fibers.

Preferably the interior of the spinner is heated by any heating means (not shown) such as by blowing in hot air or other gas. The temperature of the spinner is preferably from about 150°C to about 450°C but can vary depending on the type of glass and polymer.

25 A heating means such as annular hot air supply 42 can optionally be positioned outside the spinner to heat either the spinner or the fibers, to facilitate the fiber attenuation and maintain the temperature of the spinner at the level for optimum centrifugation of the glass and polymer.

The interior of the spinner is supplied with separate streams of molten  
30 glass and molten polymer, a first stream containing glass and a second stream containing polymer. If desired, the streams of molten glass and molten polymer can be supplied by injection under pressure. The molten glass in the first stream drops from a first delivery

tube 44 directly onto the bottom wall and flows outwardly due to the centrifugal force toward the peripheral wall to form a head of glass indicated as "A" in Fig. 2. The molten polymer, delivered via a second delivery tube 46, is positioned closer to the peripheral wall than the first stream, and molten polymer is intercepted by annular horizontal flange 5 48 before it can reach the bottom wall. Thus, a build-up or head of molten polymer, indicated as "B" in Fig. 2, is formed above the horizontal flange as shown. It is understood that the molten glass and molten polymer could also be supplied so that the molten glass is intercepted by the annular horizontal flange and the molten polymer drops to the bottom wall.

10 As shown in Fig. 3, the spinner is adapted with a vertical interior wall 50 which is generally circumferential and positioned radially inwardly from the peripheral wall 32. A series of vertical baffles 52, positioned between the peripheral wall and the vertical interior wall, divide that space into a series of generally vertically-aligned compartments 54 which run substantially the entire height of the peripheral wall. It can 15 be seen that the horizontal flange, vertical interior wall, and vertical baffles together comprise a divider for directing the molten glass "A" and molten polymer "B" into alternate adjacent compartments so that every other compartment contains molten glass "A" while the remaining compartments contain molten polymer "B".

The peripheral wall is adapted with orifices 56 which are positioned 20 adjacent the radially outward end of the vertical baffle. Each orifice has a width greater than the width of the vertical baffle, thereby enabling a flow of both molten glass "A" and molten polymer "B" to emerge from the orifice as a single bicomponent fiber of glass and polymer. As can be seen in Fig. 3, each compartment 54 runs the entire height of the peripheral wall 32 with orifices along the entire vertical baffle separating the 25 compartments. Preferably, the peripheral wall has from about 200 to about 5,000 orifices, depending on the spinner diameter and other process parameters.

As shown in Fig. 4, the orifices 56 are in the shape of slots, although other shapes of orifices can be used. The molten glass "A" usually has a higher viscosity than the molten polymer "B" at the temperature of the peripheral wall. Consequently, an 30 orifice perfectly centered about the vertical baffle would be expected to emit a higher throughput of the lower viscosity polymer than the throughput of the higher viscosity glass. One method to counteract this tendency and to balance the throughputs of the

molten glass and molten polymer, is to increase the height of the head of molten glass "A" relative to the height of the head of molten polymer "B". Another method to balance the throughputs of the molten glass and molten polymer is to position the slot orifice so that it is offset from the centerline of the vertical baffle 52. As shown in Fig. 4, the orifice will have a smaller end 58 which will restrict the flow of the lower viscosity polymer "B", and a larger end 60 which will enable a comparable flow or throughput of the higher viscosity glass "A". Another method to balance the throughputs of the molten glass and molten polymer is to restrict the flow of polymer into the alternate compartments containing the low viscosity polymer, thereby partially starving the holes so that the throughputs of molten glass and molten polymer are roughly equivalent. The orifice can also be centered about the vertical baffle when the molten glass and molten polymer have similar viscosities or when different throughputs are desirable.

Fig. 5 illustrates a portion of a second embodiment of the spinner. Like the first embodiment shown in Fig. 4, the spinner is adapted with vertical baffles 62 extending between a vertical interior wall 64 and the peripheral wall 66 to form compartments 68. The peripheral wall is adapted with rows of orifices 70 which are positioned adjacent the radial outward end of the vertical baffle. The orifices are in the shape of a "V", with one end or leg leading into a compartment containing molten glass "A" and one leg leading into a compartment containing molten polymer "B". The flows of both molten glass "A" and molten polymer "B" join and emerge from the orifice as a single bicomponent fiber of glass and polymer.

Fig. 6 illustrates a third embodiment of the spinner. The spinner 72 includes a peripheral wall 74 and a bottom wall 76. The bottom wall slants upwardly as it approaches the peripheral wall. The interior of the spinner is supplied with separate streams of molten glass and molten polymer. The molten glass in the first stream drops from a first delivery tube 78 directly onto the bottom wall and flows outwardly and upwardly due to centrifugal force toward the peripheral wall to form a head of molten glass indicated as "A" in Fig. 6. The molten polymer, delivered via a second delivery tube 80, is positioned closer to the peripheral wall than the first stream, and the molten polymer is intercepted by annular horizontal flange 82 before it can reach the bottom wall. Thus, a build-up or head of molten polymer, indicated as "B" in Fig. 6, is formed above the horizontal flange as shown.



The peripheral wall is adapted with a row of orifices 84 around its circumference, the orifices being positioned adjacent the radially outward end of the horizontal flange. As can be seen in Fig. 7, each orifice is in the shape of a "Y", with one arm leading to the molten glass "A", the other arm leading to the molten polymer "B", and  
5 the base leading to the exterior of the peripheral wall. The flows of both molten glass and molten polymer join and emerge from the orifice as a single bicomponent fiber 86 of glass and polymer.

Other spinner configurations can also be used to supply streams of molten glass and molten polymer to the spinner orifices.

10 The bicomponent fibers of this invention can be formed from many different kinds of glass and thermoplastic material. Usually the softening point of glass is significantly higher than the melting point of a thermoplastic material. Under ordinary circumstances, if molten thermoplastic material is exposed to the higher temperature of molten glass, there is a problem of thermal degradation of the thermoplastic material. It is  
15 believed that the bicomponent fibers formed by the rotary process of this invention substantially avoid thermal degradation of the thermoplastic material. The molten bicomponent streams are formed, centrifuged and cooled so rapidly that the molten thermoplastic material is exposed to the higher temperature of the molten glass for only a fraction of a second. The spinner can be provided with an inert atmosphere or insulating  
20 material between the molten glass and the molten thermoplastic material to further avoid any significant thermal degradation.

Generally, however, the bicomponent fibers of this invention are formed from a low softening glass and a high melting thermoplastic material so that the two components have similar fiber forming temperatures. For purposes of this invention, the  
25 glass will be characterized by the temperature at which its viscosity is 1000 poise, as measured according to ASTM C965. The thermoplastic material will be characterized by its melting point as determined using DSC (Differential Scanning Calorimetry). It is understood that use of the term "melting point" does not strictly apply to some classes of thermoplastic materials, specifically amorphous materials. In such cases, the term  
30 "melting point" means the temperature at which the material softens and is easily flowable so that it can be fiberized, as known to persons skilled in the art.

Preferably the temperature at which the viscosity of the glass is 1000 poise is within about 200°C of the melting point of the thermoplastic material, more preferably within about 150°C, and most preferably within about 100°C. The temperature at which the viscosity of the glass is 1000 poise is less than about 600°C, preferably less than about 550°C, more preferably less than about 500°C, more preferably from about 200°C to about 495°C, and most preferably from about 260°C to about 445°C. The melting point of the thermoplastic material is above about 140°C, preferably from about 200°C to about 345°C, and more preferably from about 260°C to about 345°C. The glass and thermoplastic material can be modified to adjust these temperatures.

Preferred low softening glasses are high-borate glasses and high-phosphate glasses. The term "high-borate glass" means that the glass composition has a B<sub>2</sub>O<sub>3</sub> content greater than about 8% by weight of the total glass composition. A particularly preferred high-borate glass has a composition by weight percent of from about 0% to about 10% SiO<sub>2</sub>, from about 0% to about 8% Al<sub>2</sub>O<sub>3</sub>, from about 70% to about 92% PbO, and from about 8% to about 25% B<sub>2</sub>O<sub>3</sub>. The temperature at which the viscosity of a high-borate glass is 1000 poise is usually from about 300°C to about 500°C. Some examples of the compositions by weight% of suitable high-borate glasses, and the temperature at which their viscosity is 1000 poise, are shown below in Table I:

Table I

20	B <sub>2</sub> O <sub>3</sub>	9.7	19.6	9.6	18.6	10	9.9
	SiO <sub>2</sub>	0.8	0.6	10.4		5	5
	PbO	89.5	79.8	80	74.6	82	80.2
	Al <sub>2</sub> O <sub>3</sub>				6.8	3	
	AlF <sub>3</sub>						4.9
25	T (°C)	427	494	538	497	431	399

The term "high-phosphate glass" means that the glass composition has a P<sub>2</sub>O<sub>5</sub> content greater than about 20% by weight of the total glass composition. A particularly preferred high-phosphate glass has a composition by weight percent of from about 50% to about 80% P<sub>2</sub>O<sub>5</sub>, from about 10% to about 30% Na<sub>2</sub>O and K<sub>2</sub>O, from about 0% to about 30% PbO, from about 0% to about 7% Al<sub>2</sub>O<sub>3</sub>, and from about 0% to about 15% other oxides such as ZnO, MgO, CaO, SnO and BaO. The temperature at which the viscosity of a high-phosphate glass is 1000 poise is usually from about 200°C to about

500°C. Some examples of the compositions by weight% of suitable high-phosphate glasses, and the temperature at which their viscosity is 1000 poise, are shown below in Table II:

5	P <sub>2</sub> O <sub>5</sub>	61.2	71.8	59.2	27.4	26	19
	Na <sub>2</sub> O	6.5					
	K <sub>2</sub> O	9.8	19.6	19			
	ZnO	4.3	2.1	4.1			
	PbO	11.6		11.3	10.7	7.2	9.3
10	AlF <sub>3</sub>	6.6	6.5	6.4			
	SnO				37.8	30.8	25.8
	SnF <sub>2</sub>				24	35.9	45.9
	T(°C)	530	499	492	289	247	179

If desired or necessary, additives such as fluorides or other halides, thallium oxide or alkali oxides can be added to the glass to lower the temperature at which its viscosity is 1000 poise. A preferred low softening glass containing fluorine is disclosed in U.S. Pat. No. 4,379,070 to Fick, and in Phys. & Chem. Glasses, Vol. 70, pp. 49-55, 1988. Other low softening glasses, and mixtures of glasses, can also be used.

The thermoplastic material used for forming the multicomponent fibers can be selected from a wide variety of suitable thermoplastic materials known for use in making fibers. Preferred high melting thermoplastic materials are selected from the following polymers: poly(phenylene sulfide) ("PPS"), poly(ethylene terephthalate) ("PET"), poly(butylene terephthalate) ("PBT"), polycarbonate, polyamide, and mixtures thereof. Polyolefins and asphalt are also suitable but less preferred because they are somewhat lower melting or softening. Other high melting thermoplastic materials, amorphous thermoplastic materials, and mixtures of thermoplastic materials, can also be used.

An advantage of the rotary process of this invention is that the viscosities of the molten glass and molten thermoplastic material are not required to be close to one another. The two viscosities can be significantly different and the process still forms suitable multicomponent fibers. Usually the viscosity of molten glass is higher than the viscosity of a molten thermoplastic material. In a specific embodiment of this invention,

the viscosity of the glass, at the temperature of the peripheral wall of the spinner, is higher than that of the thermoplastic material by a factor within the range of from about 5 to about 1000, and usually from about 50 to about 500.

The bicomponent fibers of this invention have a very irregular, curvilinear nature due to the difference in thermal expansion coefficients of the glass and thermoplastic material. Such a curvilinear nature is particularly advantageous for giving the fibers excellent insulating properties when they are used in insulating materials or textiles. As the fiber cools, the thermoplastic material contracts at a faster rate than the glass. The result is stress upon the fiber, and to relieve the stress, the fiber must bend into a curve. Preferably the coefficient of thermal expansion of the thermoplastic material is higher than that of the glass by an amount greater than about 10 ppm/°C, more preferably greater than about 30 ppm/°C, more preferably greater than about 50 ppm/°C, and most preferably greater than about 70 ppm/°C. Usually the glass has a coefficient of thermal expansion from about 5 ppm/°C to about 30 ppm/°C, while the thermoplastic material is a polymer having a coefficient of thermal expansion from about 80 ppm/°C to about 120 ppm/°C.

The bicomponent fibers made by the rotary process of this invention can be formed having a smaller diameter than bicomponent fibers made by a textile process. This advantage is provided because the rotary process uses centrifugal force to attenuate the fibers instead of relying on the mechanical attenuation of the textile process. Preferably the bicomponent fibers have an average outside diameter of from about 2 microns to about 50 microns, and more preferably from about 5 microns to about 40 microns.

Each of the bicomponent fibers of the present invention is composed of glass and thermoplastic material. If one were to make a cross-section of an ideal bicomponent fiber, one half of the fiber would be glass and the other half would be thermoplastic material. In reality, a wide range of proportions of the amounts of glass and thermoplastic material may exist in the fibers, or perhaps even over the length of an individual fiber. The percentage of glass may vary within the range of from about 5% to about 95% by volume of the total fiber, with the remainder being thermoplastic material. In general, a group of fibers such as a wool pack will have many different combinations of percentages of glass and thermoplastic material, including a small fraction of fibers that

are single component. The preferred composition of the bicomponent fibers will differ depending on the application. For some applications, preferably the bicomponent fibers comprise, by volume, from about 40% to about 60% glass and from about 40% to about 60% thermoplastic material.

5                   Cross-section photographs of fibers can be obtained by mounting a bundle of fibers in epoxy with the fibers oriented in parallel as much as possible. The epoxy plug is then cross-sectioned and polished. The polished sample surface is then coated with a thin carbon layer to provide a conductive sample for analysis by scanning electron microscopy (SEM). The sample is then examined on the SEM using a backscattered-  
10 electron detector, which displays variations in average atomic number as a variation in the gray scale. For example, this analysis reveals the presence of glass and polymer by a darker and lighter region on the cross-section of the fiber, and shows the interface of the glass and polymer.

                  As shown in Fig. 8, if the glass/polymer ratio is 50:50, the interface 88  
15 between the glass 90 and the polymer 92 passes through the center 94 of the fiber cross-section. As shown in Fig. 9, where the molten polymer has a lower viscosity than the molten glass, the polymer 92 can somewhat bend around or wrap around the glass 90 so that the interface 88 becomes curved. This requires that the bicomponent glass and polymer fiber stream emanating from the spinner be maintained at a temperature  
20 sufficient to enable the low viscosity molten polymer to flow around the higher viscosity molten glass. Adjustments in the spinner operating parameters, such as hot air flow rate, blower pressure, and polymer or glass temperature, may be necessary to achieve the desired wrap of the low viscosity polymer.

                  As shown in Fig. 10, the lower viscosity polymer 92 has flowed almost all  
25 the way around the higher viscosity glass 90. One way to quantify the extent to which the lower viscosity polymer flows around the higher viscosity glass is to measure the angle of wrap, such as the angle alpha shown in Fig. 10. In some cases the lower viscosity polymer flows around the higher viscosity glass to form an angle alpha of at least 270 degrees, i.e., the lower viscosity polymer flows around the higher viscosity glass to an  
30 extent that at least 270 degrees of the circumferential surface 96 of the bicomponent glass and polymer fiber is made up of the polymer.

As shown in Fig. 11, under certain conditions the polymer 92 can flow all the way around the glass 90 so that the polymer encloses the glass to form a cladding. In that case, the entire circumferential surface 96 (360 degrees) of the bicomponent glass and polymer fiber is the polymer.

5           The method of the invention is not limited to bicomponent fibers, but rather includes other multicomponent fibers of glass and thermoplastic material such as the tricomponent fiber illustrated in Fig. 12. To form this tricomponent fiber, separate streams of first and second molten polymers 97 and 98 and molten glass 99 are supplied to a rotating spinner having an orificed peripheral wall. The first and second molten  
10 polymers and molten glass are maintained separate until combined in the orifices. One method is to use a spinner having a single row of orifices like in Fig. 6, but where the area above the annular horizontal flange 82 is separated into alternate compartments like in Fig. 5. Thus, two streams could be fed into each orifice from above the flange while a third stream is fed into each orifice from below the flange. Other spinner structures can  
15 also be used. The first and second molten polymers and molten glass are centrifuged through the orifices as a molten tricomponent stream, and the tricomponent stream is maintained at a temperature sufficient to enable one of the lower viscosity polymers 97 to flow around at least the molten glass 99. Upon cooling of the tricomponent stream, a tricomponent fiber is formed. Another method to form a tricomponent fiber is to form a  
20 molten bicomponent stream of glass and a blend of two polymers, where the polymers have different physical properties so that they separate from one another upon cooling to form fibers. The multicomponent fibers can also include more than three components. The above descriptions and comparisons of the physical properties of glass and thermoplastic material apply to each of the materials of a multicomponent fiber.

25           Bicomponent fibers in accordance with this invention include fibers in which the glass and the thermoplastic material are disposed in side by side relation with one another. The rotary apparatus described above usually forms such side by side bicomponent fibers. The bicomponent fibers of this invention also include fibers in which one of the glass and the thermoplastic material forms a core, while the other forms  
30 a sheath surrounding the core. The rotary apparatus can be specially constructed by methods known in the art to form sheath and core bicomponent fibers. In general, such apparatus feeds one molten component through orifices which form a sheath, and feeds

the other molten component into the interior of the sheath to form a core. Combinations of different kinds of fibers can also be formed. The multicomponent fibers of the invention can also be shaped fibers, produced by shaping the orifice so that fibers are formed having a non-circular cross section. Methods of manufacturing shaped fibers are disclosed in U.S. Patent Nos. 4,636,234 and 4,666,485 to Huey et al.

Bicomponent fibers of glass and polymer of this invention could be formed according to the following example. The glass used to make the fibers is a high-borate glass. The temperature at which the glass has a viscosity of 1000 poise is about 399°C. The glass has a coefficient of thermal expansion of about 10 ppm/°C. The polymer used to make the fibers is poly(phenylene sulfide). The polymer has a melting point of about 285°C and a coefficient of thermal expansion of about 100 ppm/°C. Separate streams of molten glass and molten polymer are supplied to the spinner illustrated in Figs. 2 and 3 having a temperature of about 360°C at the peripheral wall. At this temperature, the viscosity of the glass is about 5,600 poise and the viscosity of the polymer is about 3,000 poise. The spinner has a diameter of about 38 cm and is rotated to provide a radial acceleration of about 7,600 meters/second<sup>2</sup>. The spinner peripheral wall is adapted with 350 orifices. Bicomponent streams of molten glass and molten polymer are centrifuged through the orifices. The streams are cooled to make bicomponent glass and polymer fibers which are collected as a wool pack. The average outside diameter of the fibers is about 25 microns.

The principle and mode of operation of this invention have been explained and illustrated in its preferred embodiment. However, it must be understood that this invention may be practiced otherwise than as specifically explained and illustrated without departing from its spirit or scope.

25

#### INDUSTRIAL APPLICABILITY

The multicomponent fibers of this invention are useful in many applications including apparel products, thermal and acoustical insulation products, filtration products, and as binders in composite materials.

CLAIMS

1. A method for making multicomponent fibers of glass and thermoplastic material comprising:  
supplying molten glass and molten thermoplastic material to a  
5 rotating spinner (10,72) having an orificed peripheral wall (32,66,74);  
centrifuging the molten glass (A,90,99) and molten thermoplastic material (B,92,97,98) through the orifices (56,70,84) as molten multicomponent streams of glass and thermoplastic material; and  
cooling the streams to make multicomponent fibers of glass and  
10 thermoplastic material .
2. The method of Claim 1 in which the multicomponent fibers are bicomponent fibers (38,86) and the melting point of the thermoplastic material is within about 200°C of the temperature at which the viscosity of the glass is 1000 poise.
3. The method of Claim 1 in which the temperature at which the  
15 viscosity of the glass (A,90,99) is 1000 poise is less than about 600°C.
4. The method of Claim 3 in which the temperature at which the viscosity of the glass (A,90,99) is 1000 poise is from about 200°C to about 495°C.
5. The method of Claim 1 in which the glass (A,90,99) has a B<sub>2</sub>O<sub>3</sub> content of greater than about 8% by weight of the total glass composition.
- 20 6. The method of Claim 1 in which the glass (A,90,99) has a P<sub>2</sub>O<sub>5</sub> content of greater than about 20% by weight of the total glass composition.
7. The method of Claim 1 in which the thermoplastic material (B,92,97,98) has a melting point above about 140°C.
8. The method of Claim 7 in which the thermoplastic material  
25 (B,92,97,98) has a melting point from about 260°C to about 345°C.
9. The method of Claim 1 in which the thermoplastic material (B,92,97,98) is selected from the group consisting of poly(phenylene sulfide), poly(ethylene terephthalate), poly(butylene terephthalate), polycarbonate, polyamide, polyolefins, asphalt, and mixtures thereof.
- 30 10. The method of Claim 9 in which the thermoplastic material (B,92,97,98) is a polymer selected from the group consisting of poly(phenylene sulfide),



poly(ethylene terephthalate), poly(butylene terephthalate), polycarbonate, polyamide, and mixtures thereof.

11. The method of Claim 1 in which the multicomponent fibers are bicomponent fibers (38, 86) and the coefficient of thermal expansion of the thermoplastic material (B,92,97,98) is higher than the coefficient of thermal expansion of the glass (A,90,99) by an amount greater than about 10 ppm/°C.

12. The method of Claim 1 in which the multicomponent fibers are bicomponent fibers (38,86) and the viscosity of the glass (A,90,99), at the temperature of the peripheral wall, is higher than said viscosity of the thermoplastic material (B,92,97,98) by a factor within the range of from about 5 to about 1000.

13. The method of Claim 1 in which the molten multicomponent streams are formed, centrifuged and cooled so as to avoid thermal degradation of the thermoplastic material (B,92,97,98) by contact with the molten glass(A,90,99).

14. Multicomponent fibers of glass (A,90,99) and thermoplastic material (B,92,97,98) comprising, by volume, from about 5% to about 95% glass and from about 5% to about 95% thermoplastic material.

15. The fibers of Claim 14 in which the melting point of the thermoplastic material (B,92,97,98) is within about 150°C of the temperature at which the viscosity of the glass (A,90,99) is 1000 poise.

16. The fibers of Claim 14 in which the temperature at which the viscosity of the glass (A,90,99) is 1000 poise is less than about 500°C.

17. The fibers of Claim 14 in which melting point of the polymer (B,92,97,98) is above about 140°C.

18. The fibers of Claim 14 in which the fibers are bicomponent fibers (38,86) having an average outside diameter of from about 5 microns to about 50 microns.

19. The fibers of Claim 14 in which the fibers are side by side bicomponent fibers.

20. The fibers of Claim 14 in which the fibers are tricomponent fibers.

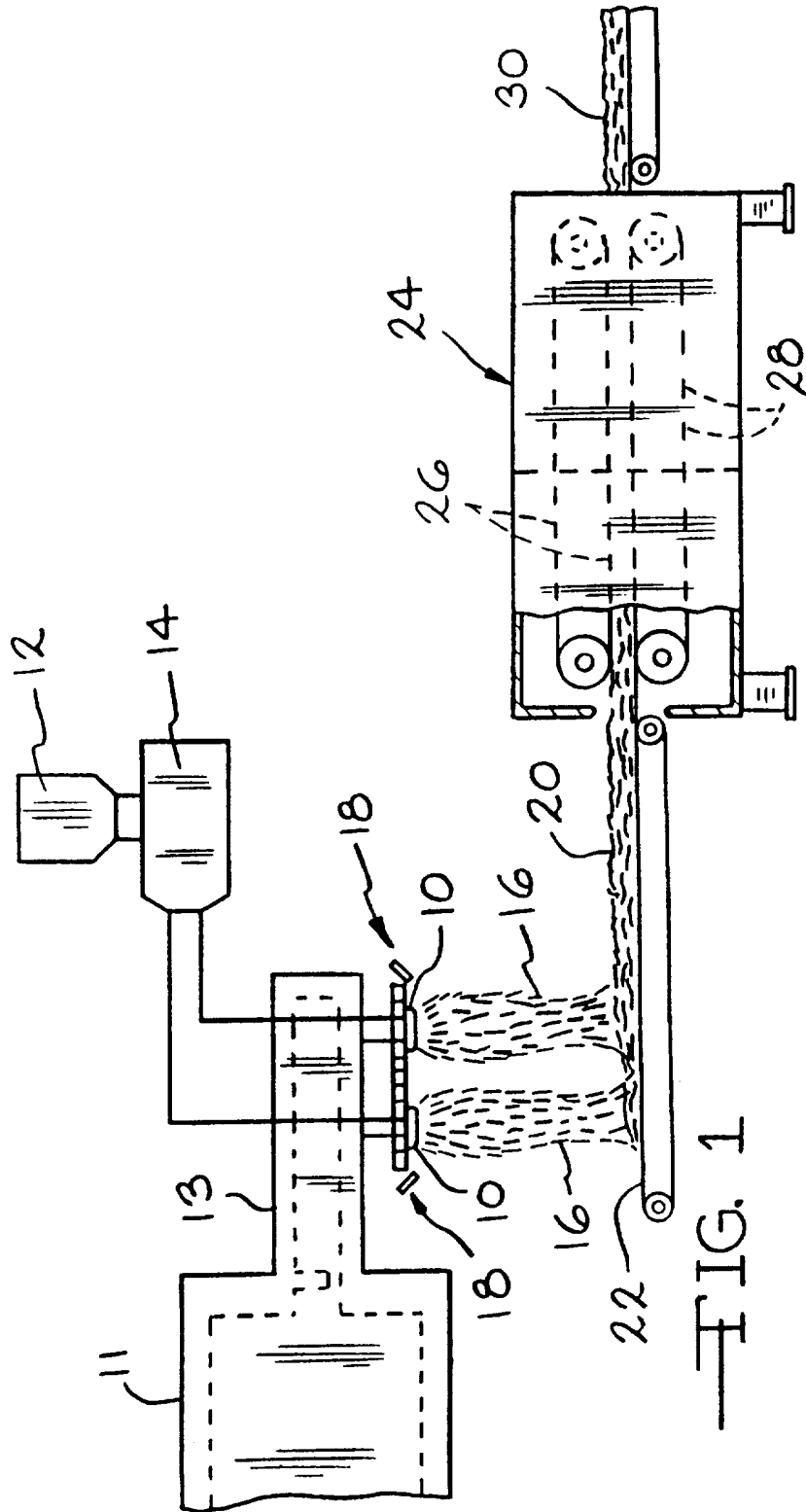
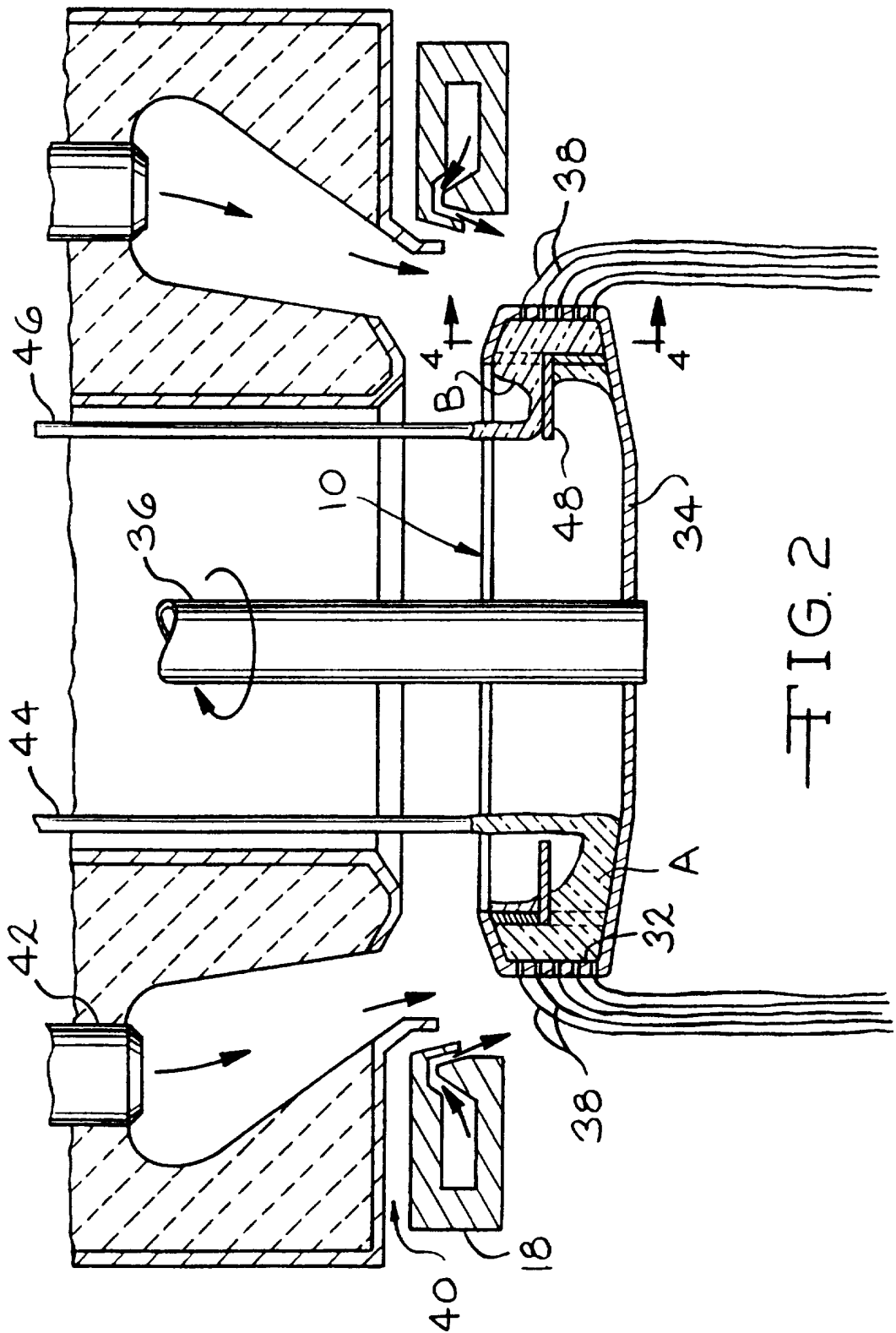

FIG. 1



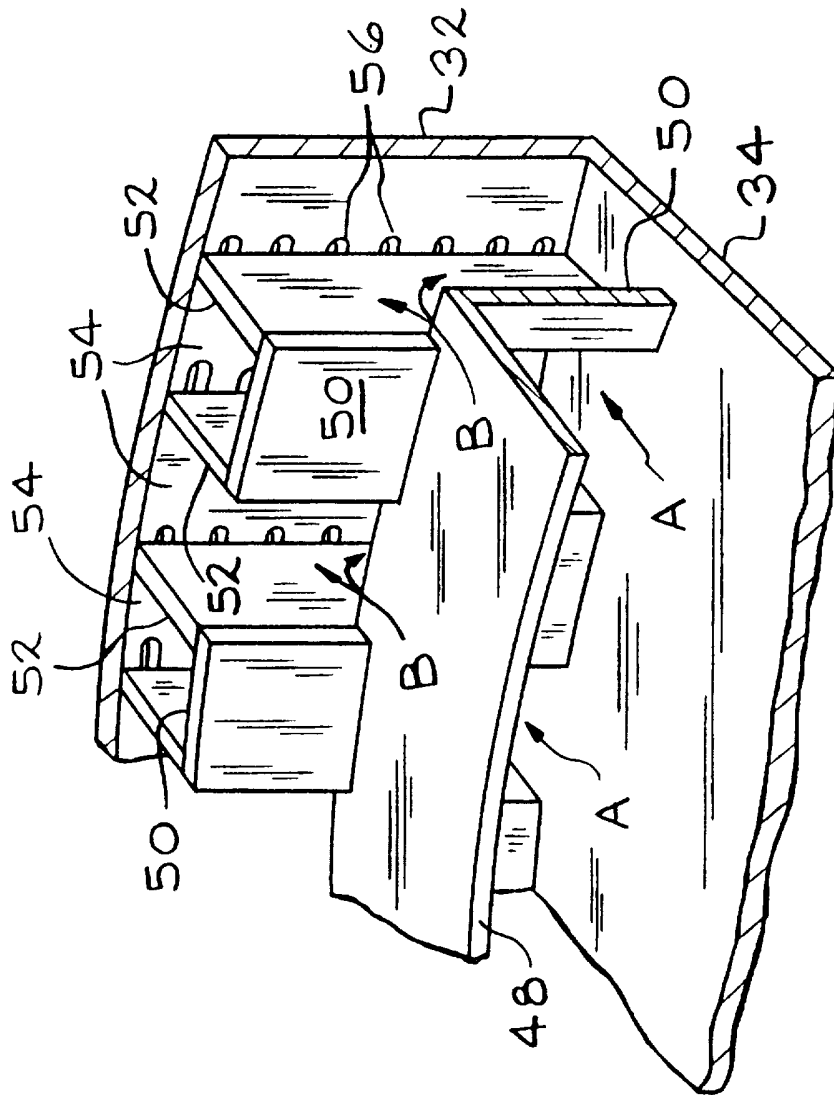

FIG. 3

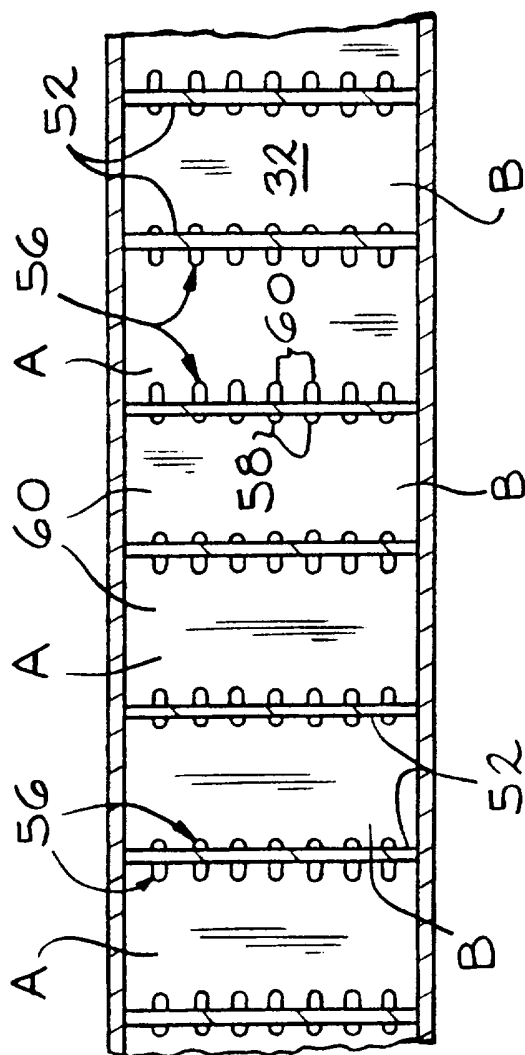

FIG. 4

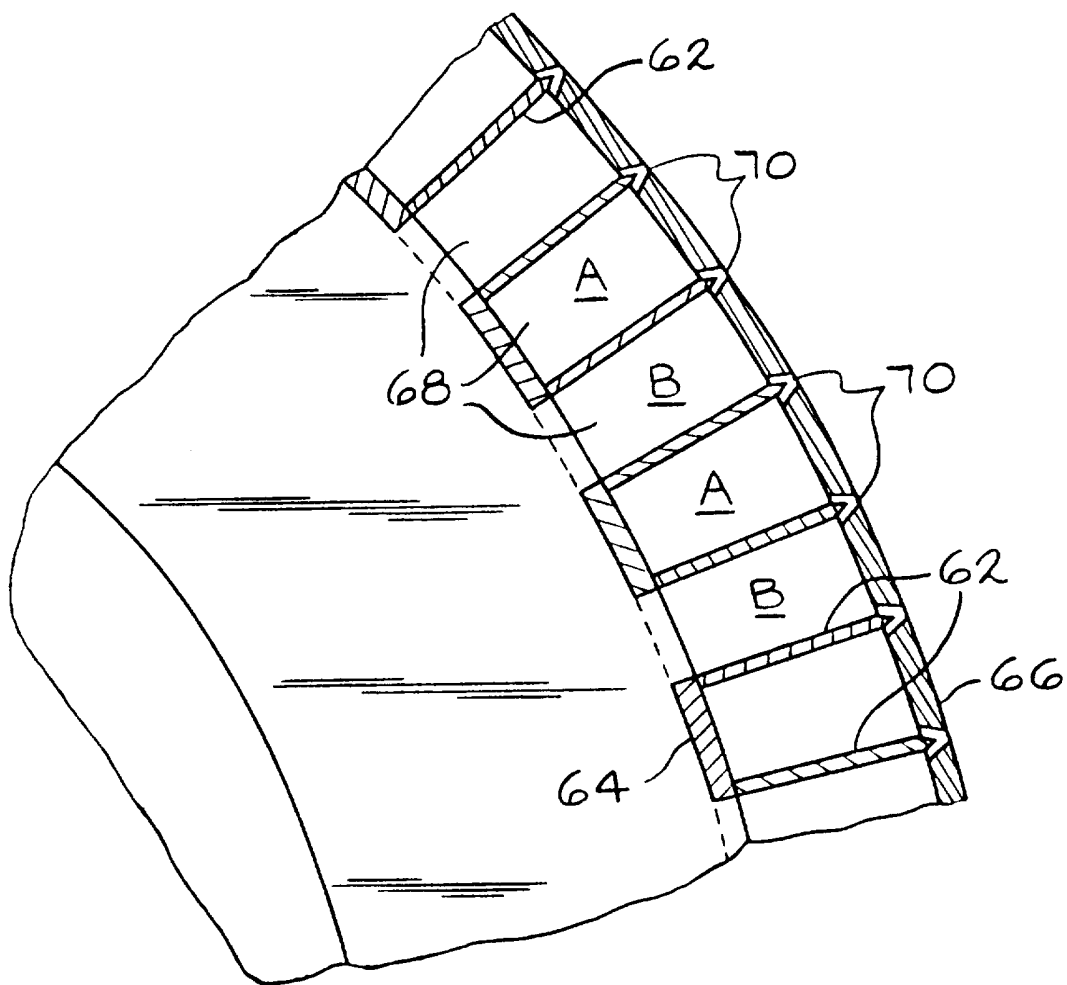

FIG. 5

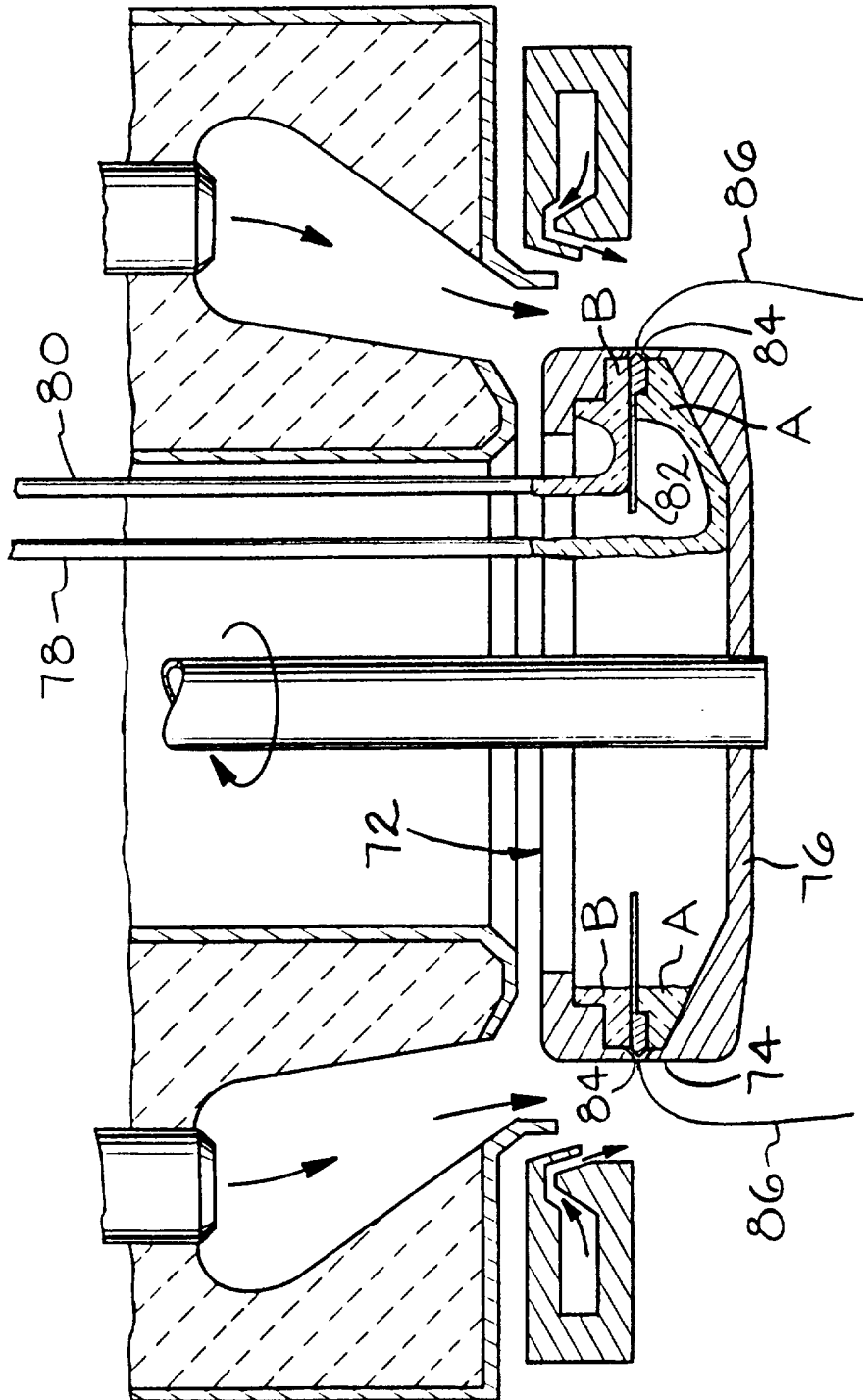

FIG. 6

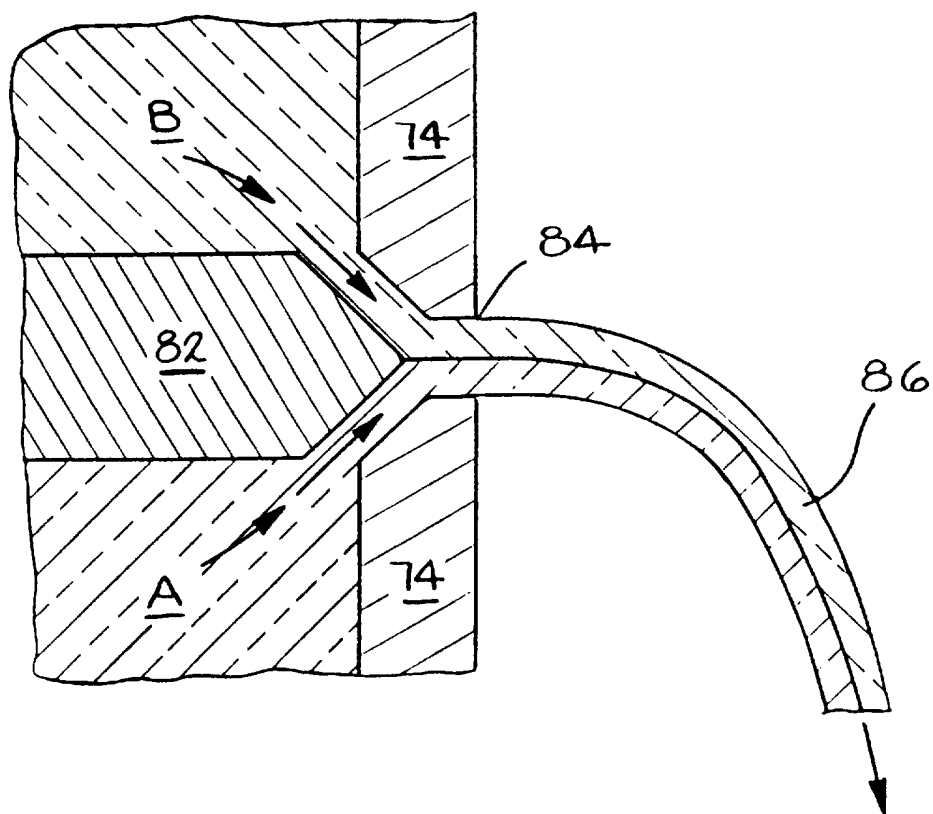

FIG. 7



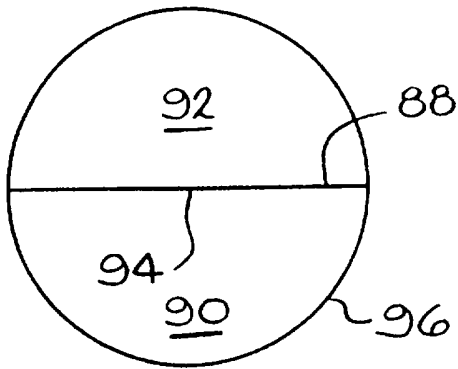

FIG. 8

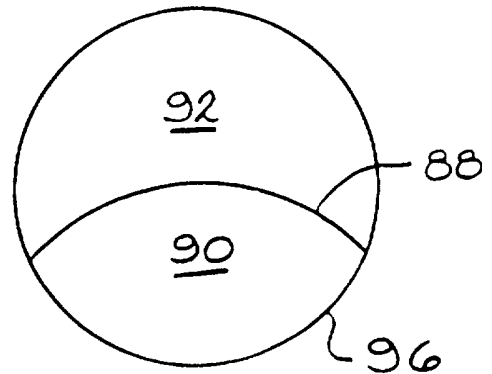

FIG. 9

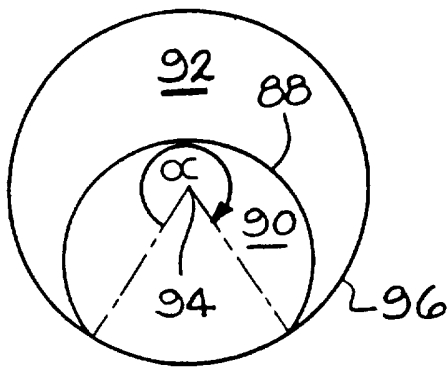

FIG. 10

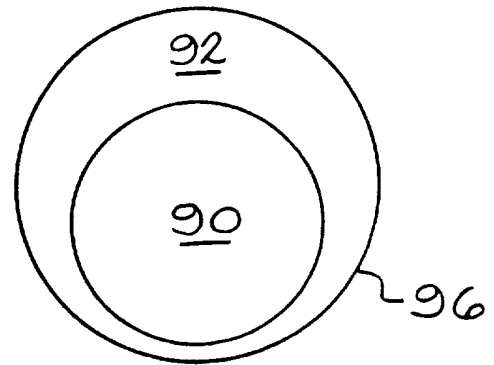

FIG. 11

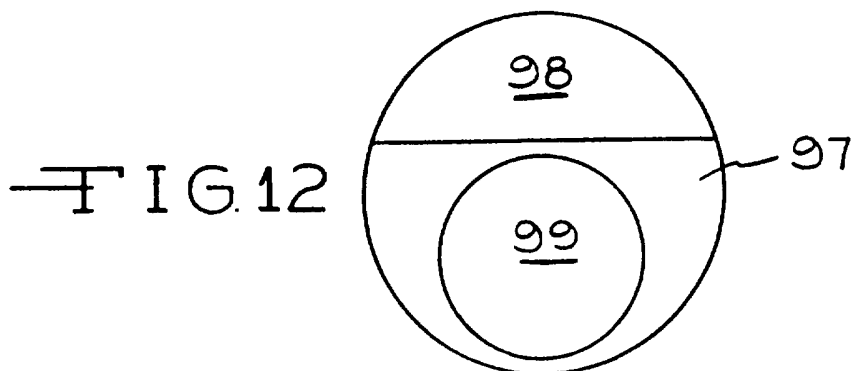
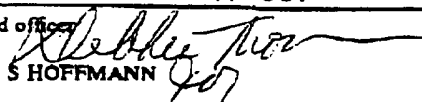

FIG. 12

# INTERNATIONAL SEARCH REPORT

International application No.  
PCT/US97/03012

<b>A. CLASSIFICATION OF SUBJECT MATTER</b>		
IPC(6) : C03B 37/04, 37/075		
US CL : 65/ 438, 450, 451, 470; 428/374		
According to International Patent Classification (IPC) or to both national classification and IPC		
<b>B. FIELDS SEARCHED</b>		
Minimum documentation searched (classification system followed by classification symbols)		
U.S. : 65/ 438, 450, 451, 470; 428/374		
Documentation searched other than minimum documentation to the extent that such documents are included in the fields searched		
Electronic data base consulted during the international search (name of data base and, where practicable, search terms used)		
APS		
<b>C. DOCUMENTS CONSIDERED TO BE RELEVANT</b>		
Category*	Citation of document, with indication, where appropriate, of the relevant passages	Relevant to claim No.
X ----- Y	US 5,474,590 A (LIN) 12 December 1995, see entire document	1,13-14, 17, 19 ----- 2-12, 15, 16, 18, 20
X ----- Y	US 2,998,620 A (STALEGO) 05 September 1961, see entire document.	1, 13, 14, 19, 20 ----- 2-3, 7, 11-12, 15, 18
Y	AMERICAN CHEMICAL SOCIETY, Polymer Chemistry for Mechanical Engineers, 1994, page 174.	9-10
A	US 5,456,982 A (HANSEN et al) 10 October 1995, figure 1.	
<input checked="" type="checkbox"/> Further documents are listed in the continuation of Box C. <input type="checkbox"/> See parent family annex.		
* Special category of cited documents: "A" document defining the general state of the art which is not considered to be of particular relevance "E" earlier document published on or after the international filing date "L" document which may throw doubt on priority claim(s) or which is cited to establish the publication date of another citation or other special reason (as specified) "O" document referring to an oral disclosure, use, exhibition or other means "P" document published prior to the international filing date but later than the priority date claimed	"T" later document published after the international filing date or priority date and not in conflict with the application but cited to understand the principle or theory underlying the invention "X" document of particular relevance; the claimed invention cannot be considered novel or cannot be considered to involve an inventive step when the document is taken alone "Y" document of particular relevance; the claimed invention cannot be considered to involve an inventive step when the document is combined with one or more other such documents, such combination being obvious to a person skilled in the art "A" document member of the same patent family	
Date of the actual completion of the international search		Date of mailing of the international search report
08 APRIL 1997		29 APR 1997
Name and mailing address of the ISA/US Commissioner of Patents and Trademarks Box PCT Washington, D.C. 20231 Facsimile No. (703) 305-3230		Authorized officer  JOHN S HOFFMANN Telephone No. (703) 305-0469

INTERNATIONAL SEARCH REPORT

International application No.  
PCT/US97/03012

C (Continuation). DOCUMENTS CONSIDERED TO BE RELEVANT

Category*	Citation of document, with indication, where appropriate, of the relevant passages	Relevant to claim No.
A	J 63 270812 A (NIPPON ESTER) 08 November 1988, entire document, especially the English abstract.	