

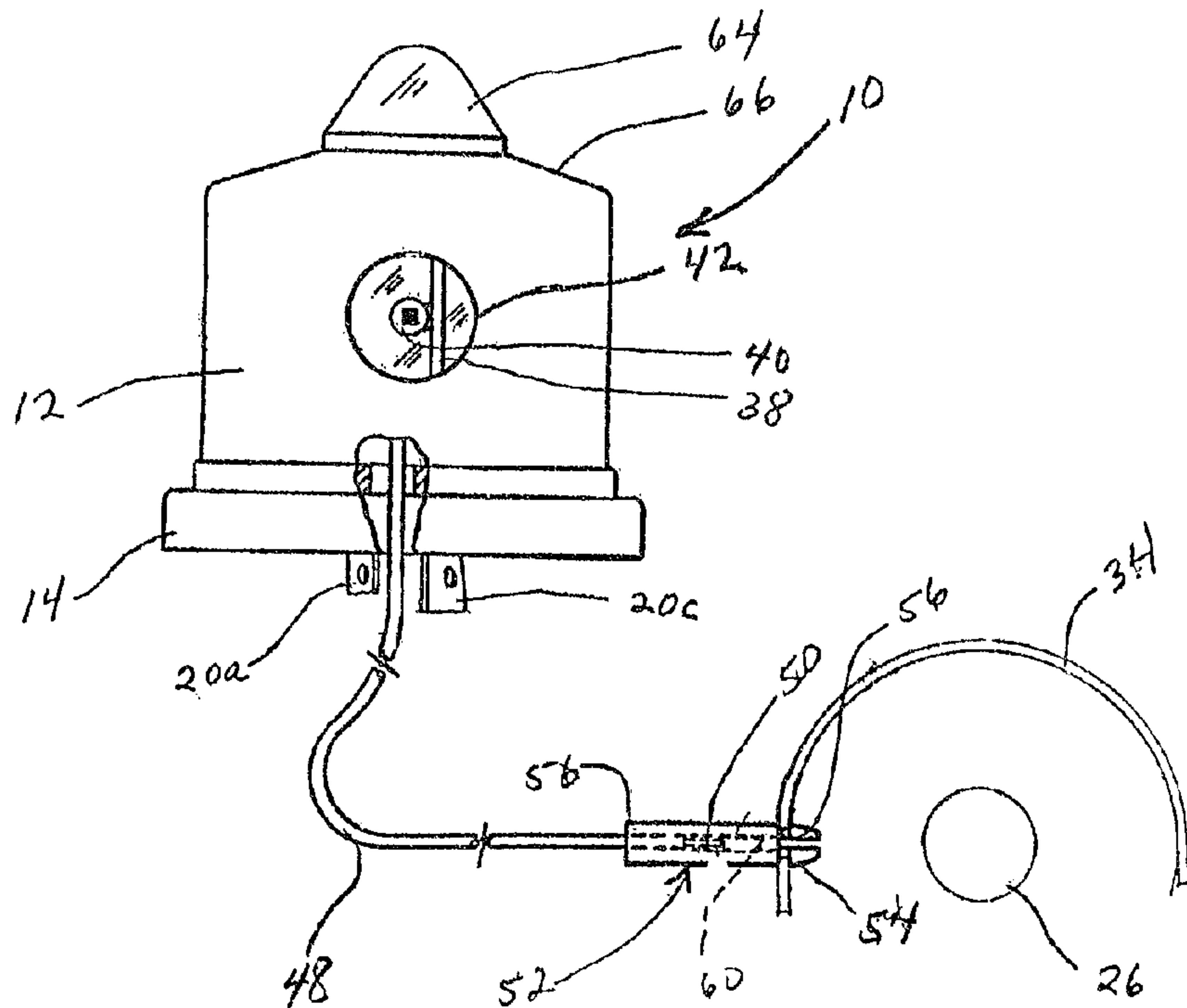

(22) Date de dépôt/Filing Date: 1992/12/29  
 (41) Mise à la disp. pub./Open to Public Insp.: 1993/07/01  
 (45) Date de délivrance/Issue Date: 2002/05/28  
 (30) Priorité/Priority: 1991/12/31 (07/815,388) US

(51) Cl.Int.<sup>5</sup>/Int.Cl.<sup>5</sup> F21V 25/04, F21V 23/00  
 (72) Inventeur/Inventor:  
 Blake, Frederick H., US  
 (73) Propriétaire/Owner:  
 Blake, Frederick H., US  
 (74) Agent: SMART & BIGGAR

(54) Titre : DISPOSITIF A FIBRES OPTIQUES POUR PREVENIR LES FLUCTUATIONS DANS LES REVERBERES  
 (54) Title: FIBER-OPTIC ANTICYCLING DEVICE FOR STREET LAMPS



(57) Abrégé/Abstract:

An anti-cycling device for high pressure sodium lamps detects an abnormal cycling condition by using a fiber-optic cable that extends between an anti-cycling controller board and the lamp itself. An outer end of the cable is arranged so that light emitted by the lamp will be transmitted to the controller board. A photocell mounted on the controller board, at the other end of the cable, transmits a variable magnitude electrical signal to the circuitry on the controller board. The signal varies in accordance with light being transmitted or not transmitted through the cable, as the case may be, corresponding to a cycling condition. In this manner, the controller board is able to detect a cycling condition, and thereby cause the power supply to the lamp to be cut off.

## Abstract of the Disclosure

An anti-cycling device for high pressure sodium lamps detects an abnormal cycling condition by using a fiber-optic cable that extends between an anti-cycling controller board and the lamp itself. An outer end of the cable is arranged so that light emitted by the lamp will be transmitted to the controller board. A photocell mounted on the controller board, at the other end of the cable, transmits a variable magnitude electrical signal to the circuitry on the controller board. The signal varies in accordance with light being transmitted or not transmitted through the cable, as the case may be, corresponding to a cycling condition. In this manner, the controller board is able to detect a cycling condition, and thereby cause the power supply to the lamp to be cut off.

## Description

## FIBER-OPTIC ANTI-CYCLING DEVICE FOR STREET LAMPS

## Technical Field

The invention disclosed here generally relates to electrical controls, and is specifically directed to high-pressure sodium lamps or luminaires that are used in street lights and in high bay lighting of interior spaces. More particularly, the invention relates to controls that are operable to detect and shut off the power to such lamps in the event they abnormally cycle as a result of sodium depletion or other causes.

## Background Art

High-pressure sodium lamps are well-known in the lighting field, and are currently in wide use by many public utilities for street lighting purposes. Although such lamps have a long life span, they eventually fail after an extended period of use because of sodium depletion. As the skilled person would know, the sodium inside the sealed glass bulb of this type of lamp becomes depleted to a point where lamp voltages can no longer maintain a continuous arc within the bulb. Furthermore, over a period of time, plating materials on lamp elements eventually cause a darkening on the inside of the bulb glass, which has a contributing effect to any given lamp's ability to maintain an arc as a result of sodium depletion. These factors typically create an abnormal cycling condition where the lamp continually flashes or attempts to start.

If abnormal cycling is allowed to continue for a long time, it eventually damages the lamp's starter/ballast unit, typically by burning out the ballast. When this happens, not only must the depleted lamp bulb be replaced, but the starter/ballast unit must be replaced as well. Having to replace the latter unit is expensive and creates higher overall costs of repair.

Further, in many modern light fixtures that fall within the high pressure sodium lamp category, electrical current

continues to be used from the power lines even when the lamp is not illuminated or is otherwise completely burned out. Even worse, some fixtures have ballasts that draw higher levels of current when the lamp is burned out than it would otherwise draw when the lamp is burning properly. In either case, the end result is an unnecessary waste of power, making it important to detect and stop an abnormal cycling condition as soon as possible.

The inventor named here is also named as a co-inventor in US Patent No. 5,103,137 which issued on April 7, 1992.

As was discussed in US Patent No. 5,103,137, few inventors or companies have successfully addressed the above-described cycling problem. The patent literature, for example, discloses that only a handful of inventions have been developed that directly relate to the problem, most of which issued within the last five years. In this regard, at the time US Patent No. 5,103,137 was filed, US Patent Nos. 4,207,500 (issued to Duve et al on June 10, 1980); 4,473,779 (issued to Lindner et al on September 25, 1984); 4,810,936 (issued to Nuckolls et al on March 7, 1989); and 4,853,599 (issued to Singarayer on August 1, 1989) fairly represented the state of the art relative to anti-cycling detection and control. Since that time, US Patent Nos. 4,881,012 (issued to Almering on November 14, 1989); 4,949,018 (issued to Siglock on May 28, 1990) and 5,019,751 (issued to Flory and Nuckolls on May 28, 1991) have also issued, and thus represent more recent attempts at solving the same problem.

The fact that most of the relevant patents in this field of technology have issued only recently illustrates how the lighting industry is now beginning to recognize the cycling problem, and the potential commercial returns that will be realized by the first inventor or company to develop a cost-effective, anti-cycling device. As of yet, it is not believed that anyone has successfully met this need.

In order to be successful, an anti-cycling device must

have the following characteristics: First, its cost to the end user, i.e. the lighting companies, must be sufficiently low in comparison to the replacement costs of starter/ballasts and lamp bulbs. Second, the installation time and labor for retrofitting existing lamps must be minimal. Lastly, the device must operate properly, regardless of the lamp or starter/ballast type.

During the course of attempting to implement the invention disclosed in US Patent No. 5,103,137 referenced above, it was discovered that the subject invention had drawbacks relating to all three of the above characteristics. Although it is believed that it does provide anti-cycling control circuitry that is extremely simple with respect to implementing the de-activation of a power supply to an abnormally cycling lamp, the mode by which cycling was detected could not be universally applied to all types of high-pressure sodium lamps. Further, it was designed to be installed as a separate unit inside the housing of a conventional street light. This entailed an unacceptable burden on the end-user, because of the labor and time involved in physically mounting the unit inside the housing, and making the necessary electrical connections to the high-voltage power lines. It is believed that many or most of the devices disclosed in the other patents referenced above have many of the same drawbacks.

As will become apparent, the invention disclosed here represents an improvement over and above the invention disclosed in US Patent No. 5,103,137 and the various other inventions referenced above. With the exception of the invention disclosed in US Patent No. 5,019,751, it is believed that prior attempts at solving the anti-cycling problem have always involved detecting a cycling condition by sensing changes in line current or voltage levels. The present invention represents a complete departure from these techniques. As will become apparent, the present invention

provides an anti-cycling device that is light-triggered. That is to say, the light from the lamp itself, as opposed to the current and voltages which cause the lamp to

burn, is what triggers the present invention. How the present invention works, including its advantages, will now be discussed and described below.

#### Summary of the Invention

5           The present invention is an anti-cycling device having an anti-cycling controller or anti-cycling control circuitry that is operable to cut off the power supply to a high pressure sodium lamp once an abnormal cycling condition has been detected. In accordance with the  
10 invention, cycling is detected by a light sensor that inputs a light-triggered signal to the controller as the lamp goes on or off, corresponding to the lit and unlit conditions which normally occur when the lamp cycles. The light sensor is adapted to directly receive light  
15 that is emitted from the lamp. In other words, the sensor generates the cycling or triggering signal by sensing light that is emitted from the lamp itself, instead of sensing changes in current and voltage that also occur during lamp cycling.

20           The present invention therefore provides for use in connection with a high-voltage, high-pressure sodium lamp, said lamp being connected to a power supply that is operable to cause said lamp to emit light, an anti-cycling device for cutting off power to said lamp in the  
25 event said lamp cycles on and off in an abnormal manner, said anti-cycling device comprising:

          an anti-cycling control circuit portion, said control circuit portion being operable to selectively cut off the power supply to said lamp; and

30           a light sensor adapted to view light that is emitted by said lamp, said light sensor being operably connected to said anti-cycling control circuit portion, and operable to generate a light-triggered cycling signal that is received by said anti-cycling control circuit  
35 portion, for enabling said control circuit portion to detect an abnormal cycling condition of said lamp, and to

cut off the power supply to said lamp in response to said abnormal cycling condition.

In preferred form, the light sensor comprises a fiber-optic cable that extends between the anti-cycling controller and the lamp. An outer end of the cable is positioned so that at least some of the light emitted by the lamp is transmitted along the cable to the controller. A photocell at the other end of the cable generates an electrical signal that varies as light is transmitted or not transmitted through the cable, as the case may be, corresponding to lamp cycling. Such signal is input into the anti-cycling circuitry making up the controller, and enables the controller to thereby detect and determine whether or not the lamp is cycling abnormally. When an abnormal cycling condition is detected, the controller causes the lamp's power supply to be cut off.

The present invention also provides a power supply/anti-cycling control unit for a street light, said street light having a high-pressure sodium lamp received within a street light housing, said lamp being connected to a power supply that is operable to supply starting and operating current and voltages to said lamp, said street light housing further having a lens in a lower side thereof through which light emitted by said lamp is transmitted onto a ground area that is normally below said housing, and a reflector wall within said housing that substantially surrounds said lamp, for directing said emitted light downwardly through said lens, and an electrical socket fitting positioned in an upper side of said housing, said power supply/anti-cycling unit comprising:

a unit housing having a cylindrically-shaped base portion that is connectable to said electrical socket fitting, said unit housing having first and second light-transmitting windows spaced apart from each other;

an ambient light photocell received within said unit housing adjacent the first window, for receiving ambient light from outside said unit housing;

5 a warning light positioned adjacent the second window, for emitting a visible light signal to a maintenance person when said anti-cycling unit detects an abnormal cycling condition of said lamp;

10 a power supply board received within said unit housing, said power supply board carrying power control circuitry that is responsive to electrical signals from said ambient light photocell, for either activating or de-activating said power supply to said lamp in response to whether or not said photocell signal indicates night or day;

15 an anti-cycling board also received within said unit housing, said anti-cycling board carrying anti-cycling control circuitry that is operable to determine said abnormal lamp cycling condition, and to signal said power control circuitry to a de-activate said power supply to  
20 said lamp and to illuminate said warning light in the event said abnormal lamp cycling condition is detected; and

further including a light sensor adapted to receive light emitted from said lamp, said light sensor being  
25 operably connected to said anti-cycling control circuitry, said light sensor being operable to generate a light-triggered cycling signal that is received by said anti-cycling control circuitry, for enabling said anti-cycling control circuitry to determine said abnormal  
30 cycling condition.

In a further embodiment, the present invention provides a device for preventing a high-voltage lamp from abnormally cycling, the device comprising:

35 an anti-cycling control circuit portion operable to cut off the power supply of the lamp in response to receipt of a cycling malfunction signal; and

a light sensor having a fiber-optic cable, one end of the cable being arranged relative to the lamp in a manner so that the cable receives and conveys at least some of the light radiation emitted by the lamp, the  
5 light sensor including a photocell arranged relative to the outer end of the cable in a manner so that the photocell receives at least some of the conveyed radiation, the photocell generating an electrical output that cycles in correspondence with abnormally cycling  
10 lamp radiation conveyed by the cable, and the output of the photocell being used to produce the cycling malfunction signal.

The various advantages of the invention will become apparent upon review of the following description which  
15 should be read in conjunction with the drawings.

#### **Brief Description of the Drawings**

In the drawings, like reference numerals and letters refer to like parts throughout the various views, unless indicated otherwise, and wherein:

20 Fig. 1 is a pictorial view of a conventional street light fixture, looking down on top of the housing for such fixture, and shows how a power supply/anti-cycling unit in accordance with the invention is mounted to an existing electrical socket fitting on top of the housing;

25 Fig. 2 is a pictorial view of the fixture shown in Fig. 1, but looking from a lower side thereof, and shows the lower half of the fixture housing in an open condition for accessing various components within the housing;

30 Fig. 3 is an enlarged pictorial view of the anti-cycling/power control unit shown in Fig. 1;

Fig. 4 is a side cross-sectional view of the unit shown in Fig. 3;

Fig. 5 is a side view of the unit shown in Figs. 3 and 4;

Fig. 6 is another side view of the unit shown in Figs. 3-5;

5 Fig. 7 is a top plan view of the unit shown in Figs. 3-6;

Fig. 8 is a bottom plan view of the unit shown in Figs. 3-7;

Fig. 9 is an assembly drawing of the power control board that is received within the unit housing shown in Figs. 3-8;

10 Fig. 10 is an electrical schematic of the power control circuitry which is mounted to or carried by the power supply board shown in Fig. 9;

Fig. 11 is an assembly drawing of an anti-cycling control board which is also received in the unit housing shown in Figs. 3-8; and

15 Fig. 12 is an electrical schematic of the anti-cycling control circuitry which is mounted to the board shown in Fig. 11.

#### Best Mode for Carrying out the Invention

20 Referring now to the drawings, and first to Fig. 1, shown generally at 10 is a power supply/anti-cycling control unit in accordance with a preferred embodiment of the invention. Referring now to Fig. 3, the unit 10 includes a hollow housing 12 that is generally cylindrical in shape. A base portion of the housing, indicated at 14, is shaped for mounting the

25 housing directly to a pre-existing electrical socket fitting 16, the latter being conventional in nature and is typically found on top of most or all modern street light fixtures 18 (see Figs. 1 and 2).

30 Three electrical prongs 20a, 20b, 20c extend downwardly from the base portion 14 of the unit 10, and are inserted into corresponding slots 22a, 22b, 22c in the socket fitting 16. After insertion, the unit 10 is turned to lock it in place relative to the lamp or light fixture 18. Such connection is

35 conventional, and would be familiar to the skilled person. The electrical prongs 20a, 20b, 20c electrically connect the unit

10 to the power lines which supply high voltage and current to the light fixture 18, including the ballast/starter 24 (see Fig. 2) and high-pressure sodium lamp 26 within the fixture's housing 28.

5 A person skilled in the art would be familiar with the light fixture 18 as it is depicted in Figs. 1 and 2 and described above. The skilled person would also know that the fixture housing 28 is hinged, as indicated at 30, and may be opened to reveal the various elements or components 24, 26  
10 located inside. As mentioned above, the electrical socket fitting 16 is located on an upper or top side of the housing 28. In the lower side, a conventional lens 32 is positioned adjacent the lamp 26. The lamp 26 is also surrounded by a reflector 34, a portion of which is schematically shown in Fig.  
15 5. Light from the lamp 26 and reflector 34 is transmitted downwardly through lens 32 to an area that underlies the lamp fixture 18.

Referring now to Fig. 4, the power supply/anti-cycling control unit 10 has a power supply board 36, and an anti-cycling control board 38, both of which are received within the  
20 unit's housing 12. The power supply board 36 is better seen in Fig. 9. Directing attention there, it is generally circular in shape, and carries the electrical elements or parts which make up the power control circuitry shown in Fig. 10. The  
25 above-described connection pins 20a, 20b, 20c extend downwardly from the power control board 36, and connect into the lamp power line as schematically shown in Fig. 10. The circuitry of Fig. 10 either enables power to be supplied to the ballast/starter 24, or cuts it off, depending on an electrical  
30 signal received from a photocell 40, the latter also being identified by part number "PC1" in Fig. 11. Such photocell 40 is positioned adjacent a first light-transmitting window 42 in a side of the unit housing 12.

Referring now to Fig. 4, the anti-cycling control board 38  
35 is vertically upstanding with respect to the power supply board 36. It is mounted directly to the power supply board 36 by suitable mechanical connections that are electrically non-

conductive. The photocell 40 described above is mounted adjacent a side edge 43 of the anti-cycling board 38, in a position so that it is adjacent to and will view ambient light directly through side window 42 (see Fig. 5).

5 The anti-cycling control board 38 carries the elements or parts making up the control circuitry shown in Fig. 12. The "POWERON" output in Fig. 12 corresponds to the same input in Fig. 10 and, as the skilled person would recognize, shows how the photocell 40 signals the power control circuitry to either  
10 supply or cut off power, depending on whether the ambient light corresponds to night or daytime conditions. A fiber-optic cable input, which is indicated generally by arrow 44 in Fig. 12, provides a triggering input to the anti-cycling circuitry shown in Fig. 12, and enables the anti-cycling circuitry to  
15 detect lamp cycling, and to cut off power to the lamp in the event a cycling condition is detected. This will now be described in further detail below.

A second photocell unit 46 is mounted directly to the anti-cycling board 38, in the location shown in Fig. 11. Such  
20 unit is also indicated by part number "D350". One end of a conventional fiber-optic cable 48 is connected to such unit, and extends downwardly through the power supply board 36, and out through the base portion of the unit housing 12 in the manner shown in Fig. 5.

25 When the unit 10 is installed or mounted on top of the light fixture 18, as shown in Fig. 1, the fiber-optic cable 48 extends all the way from the unit 10 to the reflector 36 inside the light fixture 18. The position of the cable 48 within the fixture housing 28 is best seen in Fig. 2. As the unit 10 is  
30 mounted, an outer or light-receiving end 50 of the cable 48 is passed through a small opening 49 in electrical socket fitting 16. It is believed that most fixtures like fixture 18 shown in Figs. 1 and 2, which are presently in use, already have an opening like opening 49, which makes it easy to extend the  
35 cable 48 down into the fixture housing as the unit 10 is installed. If not, it would be a relatively simple matter to create a suitable opening through the socket fitting 16.

The outer end 50 of the cable is mounted to the reflector 34 via another fitting 52. Such fitting 52 has a forward portion 54 that is snap-fit into an opening 56 made through the wall of the reflector 34. When installing the unit 10 for the first time in a retrofit situation, the maintenance person would normally create the reflector opening 56 for accommodating the snap-fit connection just described. The fiber-optic cable's outer end 50 is crimped into an outer portion 58 of the fitting 52, and is thereby held in position a certain distance that is spaced outwardly from the reflector 36.

As the skilled person would know, the reflector 36 heats up substantially after the lamp 26 has been running for a certain period of time. In order to protect the fiber-optic cable 48 from being exposed to unacceptable levels of heat, it is necessary to space it from the reflector or otherwise insulate it in some manner. Spacing the cable's end 50 from the reflector via fitting 52 accomplishes this purpose. Further, the fitting 52 should preferably be made of a substantially low heat-conducting material such as, for example, a polycarbonate material. In addition to being low heat-conducting, the fitting 52 should also be opaque to the transmission of infrared light.

The fitting 52 defines a light-transmitting passageway 60 through the reflector 36 and into the cable's outer end 50. When the lamp 26 is burning, some of its light will therefore be transmitted through fiber-optic cable 48 to the photocell 46 mounted on the anti-cycling board 38.

When the lamp 26 cycles, the corresponding "ON" and "OFF" light signal that is transmitted by the fiber-optic cable 48 causes the photocell 46 to alter its output, and thereby transmit an electrical signal that corresponds to cycling. Referring again to Fig. 12, such signal triggers a loadable counter U1 every time light in the fiber-optic cable goes from "ON" to "OFF". Upon receipt of the third triggering signal, the counter U1 outputs an error signal to a norgate U3, which

in turn signals the power supply circuitry shown in Fig. 10 to cut-off further power to the fixture 18.

At the same time, the counter U1 also activates LED D1 which is mounted to an upper edge 62 of the anti-cycling board 38. LED D1 is positioned adjacent a second window 64 in the top portion 66 of the unit housing 12. The LED D1 serves as a warning light that remains on during the following day, and would be visible through window 64 to a maintenance person, thereby informing him or her that the fixture 18 is cycling or is otherwise malfunctioning.

Table I below sets forth a parts list for the various electrical components mounted to the anti-cycling board 38. Such components should be viewed as the anti-cycling controller portion of the power supply/anti-cycling unit 10. The part numbers in Table I correspond to like part numbers in Fig. 12. Fig. 12 is a schematic of the anti-cycling control circuitry which is mounted to or carried by the anti-cycling board 38. An assembly drawing of such board is shown in Fig. 11, which also depicts the same part numbers that are displayed in Fig. 12 and in Table I.

TABLE I.

ANTI-CYCLING LOGIC BOARD  
BILL OF MATERIALS

Quantity	Reference	Part	DESCR	MFG	Part Number
3	C2, C3, C10	.33uF	CAP SMT	KEMET	C1825C334M5RAC
1	C800	1000uF	CAP T/H	MEPCO	3476HF102M010JMBS
1	R3	68	RES SMT	DALE	RC1206XXXJ
1	R4	1K	RES SMT	DALE	RC1206XXXJ
2	R8, R13	2K	RES SMT	DALE	RC1206XXXJ
1	R18	5K	RES SMT	DALE	RC1206XXXJ
2	R5, R10	10K	RES SMT	DALE	RC1206XXXJ
2	R11, R12	20K	RES SMT	DALE	RC1206XXXJ
1	R7	22K	RES SMT	DALE	RC1206XXXJ
2	R19, R20	33K	RES SMT	DALE	RC1206XXXJ
1	R9	36K	RES SMT	DALE	RC1206XXXJ
3	R2, R6, R16	100K	RES SMT	DALE	RC1206XXXJ
2	R21, R22	200K	RES SMT	DALE	RC1206XXXJ
1	R185	100K POT	POT 100K	BOURNES	3296X-1-104
1	Q1	2N3906	TRANSTR SMT	MOTOROL	MMBT3906LT1
1	D3	1N4148	DIODE T/H	MOTOROLA	
1	D1	LED	LED	STANLEY	H2000L
1	D350	MFOD71	LIGHT SENSOR T/H		MFOD71
1	PC1	PC	PHOTOCELL T018	SILONEX	NSL-4172
1	U2	LM339	QUAD CMP SMT	MOTOROLA	LM339D
1	U3	4001	QUAD NOR SMT	MOTOROLA	MC4001BD
1	U1	14161	COUNTER SMT	MOTOROLA	MC14161BD

Likewise, Table II below sets forth a parts list for the various electrical components mounted to the power supply board 36. Such board 36 should be viewed as the power controller portion of the power supply/anti-cycling unit 10. The part numbers in Table II correspond to the part numbers shown in Fig. 10. Fig. 10 depicts the power supply control circuitry which is carried by the power supply board 36. Fig. 9 is an assembly drawing of such board 36, and also displays the same part numbers that are displayed in Fig. 10 and in Table II.

TABLE II.

ANTI-CYCLING POWER BOARD  
BILL OF MATERIALS

Quantity	Reference	Part	DESCR	MFG	Part Number
1	C700	.022uF	CAP T/H	PANASONIC	ECQ-E10223KZ
1	C950	1uF	CAP T/H	1000V PANASONIC	ECQ-E10104KZ
1	C460	220uF	CAP T/H	MEPCO	3476FC221M010JMBS
1	R101	470	RES SMT	DALE	RC1206XXXJ
2	R103, R104	1K	RES SMT	DALE	RC1206XXXJ
1	R102	4.7K	RES SMT	DALE	RC1206XXXJ
1	R680	MOV	VSTR T/H,	400V PANASONIC	ERZ C10DK681U
1	Q101	2N2222	TRANSTR	SMT MOTOROLA	MMBT2222LT1
1	Q200	MOC3083	OPTOISLTR	SMT MOTOROLA	MOC3083
1	Q775	MAC22810	TRIAC T/H	MOTOROLA	MAC22810
4	D101, D102, D103, D104	1N4004	DIODE T/H	MOTOROLA	
1	D105	1N4101	DIODE SMT	MOTOROLA	MMBZ5237B
1	U101	LM7805	VLT REG	SMT MOTOROLA	MC78L05
1	R105	1 WATT			

The skilled person, having the benefit of the information listed on Tables I and II, along with the electrical schematics shown in Figs. 10 and 12, could easily ascertain how the invention works, and could easily build it in the form depicted in Figs. 1-5, or otherwise adapt the circuitry of Figs. 10 and 12 to a different form of power supply/anti-cycling unit.

The fitting 52 which is connected to the reflector 34; the fiber-optic cable 48 which extends from the fitting 52 to the photocell 46 on the anti-cycling control board; and the photocell 46 itself, together define a light sensor that is operable to create a light-triggered signal that is input to the anti-cycling controller or, in other words, the anti-cycling control circuitry shown in Fig. 12. Unlike other anti-cycling devices, the controller or control circuitry shown in Fig. 12 is therefore not triggered by monitoring voltage or current that is supplied to either the ballast/starter unit 24 or the lamp 26 of the light fixture 18. Instead, it is the

light which is emitted directly by the lamp 26 itself,  
transmitted via fiber-optic cable 48, which provides the  
triggering signal. Detecting anti-cycling in this way,  
eliminates any need for more complicated voltage and/or current  
5 sensing methods.

The above description sets forth the best mode for carrying  
out the invention claimed here as it is presently known. It  
is conceivable that there will be future improvements and/or  
modifications to the power supply/anti-cycling control unit  
10 described above. For this reason, the preceding description  
should not be viewed as limiting the scope of what is intended  
to be the invention. Instead, the scope of the invention is  
to be limited only by the subjoined claims which follow, the  
interpretation of which is to be made in accordance with the  
15 established doctrines of claim interpretation.

The embodiments of the invention in which an exclusive property or privilege is claimed are defined as follows:

1. For use in connection with a high-voltage,  
5 high-pressure sodium lamp, said lamp being connected to a power supply that is operable to cause said lamp to emit light, an anti-cycling device for cutting off power to said lamp in the event said lamp cycles on and off in an abnormal manner, said anti-cycling device comprising:  
10 an anti-cycling control circuit portion, said control circuit portion being operable to selectively cut off the power supply to said lamp; and  
a light sensor adapted to view light that is emitted by said lamp, said light sensor being operably connected  
15 to said anti-cycling control circuit portion, and operable to generate a light-triggered cycling signal that is received by said anti-cycling control circuit portion, for enabling said control circuit portion to detect an abnormal cycling condition of said lamp, and to  
20 cut off the power supply to said lamp in response to said abnormal cycling condition.

2. The anti-cycling device of claim 1, wherein said light sensor comprises a fiber-optic cable that is operable to transmit at least some of the lamplight  
25 emitted by said lamp, said cable extending from said control circuit portion to a position adjacent said lamp such that an outer end of said cable is positioned to receive said emitted lamplight, said light sensor further including a photocell positioned adjacent the other end  
30 of said cable, for receiving lamplight transmitted by said cable, said photocell generating an electrical signal that varies as light is transmitted or not transmitted through said cable, corresponding to lamp cycling between lit and unlit conditions, said electrical  
35 signal producing said triggering signal that is received by said anti-cycling control circuit portion, for

enabling said control circuit portion to detect said abnormal cycling condition.

3. The anti-cycling device of claim 2, wherein a reflector substantially surrounds said lamp and defines a light-reflecting wall, and said light sensor further includes a fitting that is connected to said lamp reflector, for mounting said outer end of said fiber-optic cable to said reflector, said fitting defining a light passageway through said light-reflecting wall for guiding emitted lamplight into said outer end of said cable.

4. The anti-cycling device of claim 3, wherein a portion of said fitting is received within an opening that extends through said light-reflecting wall, and said outer cable end is connected to another portion of said fitting, in a manner so that said outer cable end is outwardly spaced from contact with said reflector.

5. The anti-cycling device of claim 3, wherein said fitting is made of a low heat-conducting, high-temperature material.

6. The anti-cycling device of claim 3, wherein said fitting is made from a material that is substantially opaque to infrared light.

7. The anti-cycling device of claim 2, including means for insulating said outer end of said cable from heat generated by said lamp.

8. The anti-cycling device of claim 2, wherein said outer end of said cable is substantially opaque to infrared radiation.

9. A power supply/anti-cycling control unit for a street light, said street light having a high-pressure sodium lamp received within a street light housing, said lamp being connected to a power supply that is operable  
5 to supply starting and operating current and voltages to said lamp, said street light housing further having a lens in a lower side thereof through which light emitted by said lamp is transmitted onto a ground area that is normally below said housing, and a reflector wall within  
10 said housing that substantially surrounds said lamp, for directing said emitted light downwardly through said lens, and an electrical socket fitting positioned in an upper side of said housing, said power supply/anti-cycling unit comprising:

15 a unit housing having a cylindrically-shaped base portion that is connectable to said electrical socket fitting, said unit housing having first and second light-transmitting windows spaced apart from each other;

an ambient light photocell received within said unit  
20 housing adjacent the first window, for receiving ambient light from outside said unit housing;

a warning light positioned adjacent the second window, for emitting a visible light signal to a maintenance person when said anti-cycling unit detects an  
25 abnormal cycling condition of said lamp;

a power supply board received within said unit housing, said power supply board carrying power control circuitry that is responsive to electrical signals from said ambient light photocell, for either activating or  
30 de-activating said power supply to said lamp in response to whether or not said photocell signal indicates night or day;

an anti-cycling board also received within said unit housing, said anti-cycling board carrying anti-cycling  
35 control circuitry that is operable to determine said abnormal lamp cycling condition, and to signal said power control circuitry to a de-activate said power supply to

said lamp and to illuminate said warning light in the event said abnormal lamp cycling condition is detected; and

5 further including a light sensor adapted to receive light emitted from said lamp, said light sensor being operably connected to said anti-cycling control circuitry, said light sensor being operable to generate a light-triggered cycling signal that is received by said anti-cycling control circuitry, for enabling said anti-cycling control circuitry to determine said abnormal  
10 cycling condition.

10. The power supply/anti-cycling control unit of claim 9, wherein said power supply board is a circular board that is positioned horizontally within said unit housing adjacent said base portion thereof, and said  
15 anti-cycling board is mounted to said power supply board, and upstands vertically relative to said power supply board, and wherein said first window is positioned in a sidewall of said unit housing adjacent an edge of said anti-cycling board, with said photocell being mounted  
20 adjacent said edge and adjacent said first window, and wherein said second window is positioned in a top portion of said unit housing, such top portion being near an upper edge of said anti-cycling board, said warning light  
25 being mounted adjacent said upper edge and adjacent said second window, in a manner so that said warning light is visible through said second window.

11. The power supply/anti-cycling control unit of claim 9, wherein said light sensor comprises a fiber-  
30 optic cable that is operable to transmit at least some of said emitted lamplight, with said cable extending from said anti-cycling board to a position adjacent said lamp such that an outer end of said cable directly receives emitted lamplight, said light sensor including a  
35 lamplight photocell mounted to said anti-cycling board

that is positioned adjacent the other end of said cable, for receiving lamplight transmitted by said cable, said lamplight photocell generating an electrical signal that varies as light is transmitted or is not transmitted  
5 through said cable, corresponding to lamp cycling between lit and unlit conditions, said electrical signal being input to said anti-cycling control circuitry and defining said light-triggered anti-cycling signal, for enabling said anti-cycling control circuitry to detect said  
10 abnormal cycling condition.

12. The power supply/anti-cycling control unit of claim 11, wherein said light sensor further includes a fitting that is connectable to said reflector wall within said street light housing, for mounting said outer end of  
15 said fiber-optic cable to said reflector wall, said fitting defining a light passageway through said reflector wall for guiding emitted lamplight into said outer end of said cable, a portion of said fitting being received within an opening that extends through said  
20 reflector wall, and said outer cable end being connected to another portion of said fitting, in a manner so that said outer end is outwardly spaced from contact with said reflector wall.

13. The power supply/anti-cycling control unit of  
25 claim 12, wherein said fitting is made of a low heat-conducting, high-temperature material.

14. The power supply/anti-cycling control unit of claim 12, wherein said fitting is made from a material that is substantially opaque to infrared light.

30 15. The anti-cycling device of claim 11, including means for insulating said outer end of said cable from heat generated by said lamp.

16. The anti-cycling device of claim 11, wherein said outer end of said cable is substantially opaque to infrared radiation.

17. A device for preventing a high-voltage lamp  
5 from abnormally cycling, the device comprising:

an anti-cycling control circuit portion operable to cut off the power supply of the lamp in response to receipt of a cycling malfunction signal; and

10 a light sensor having a fiber-optic cable, one end of the cable being arranged relative to the lamp in a manner so that the cable receives and conveys at least some of the light radiation emitted by the lamp, the light sensor including a photocell arranged relative to the outer end of the cable in a manner so that the  
15 photocell receives at least some of the conveyed radiation, the photocell generating an electrical output that cycles in correspondence with abnormally cycling lamp radiation conveyed by the cable, and the output of the photocell being used to produce the cycling  
20 malfunction signal.

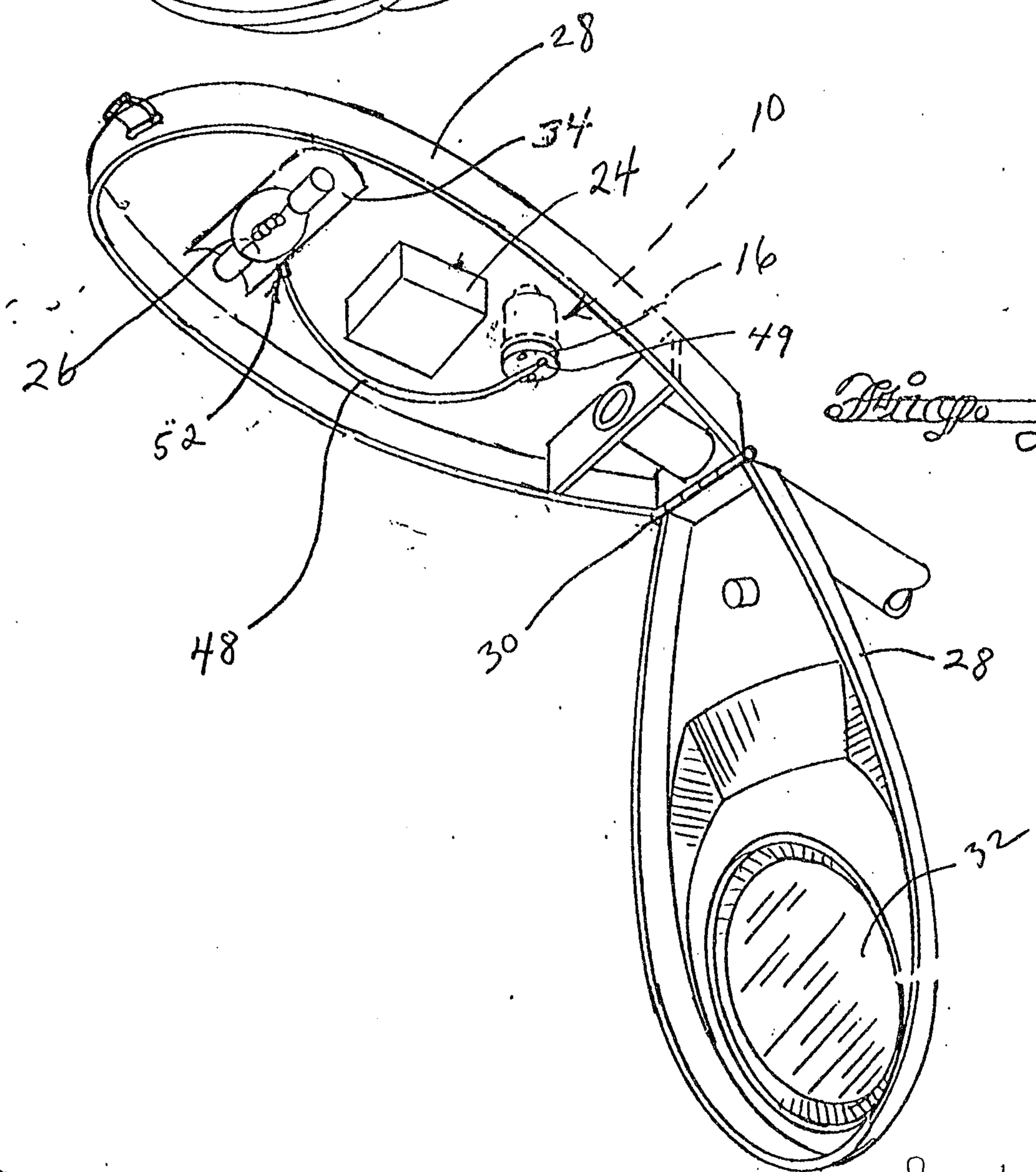
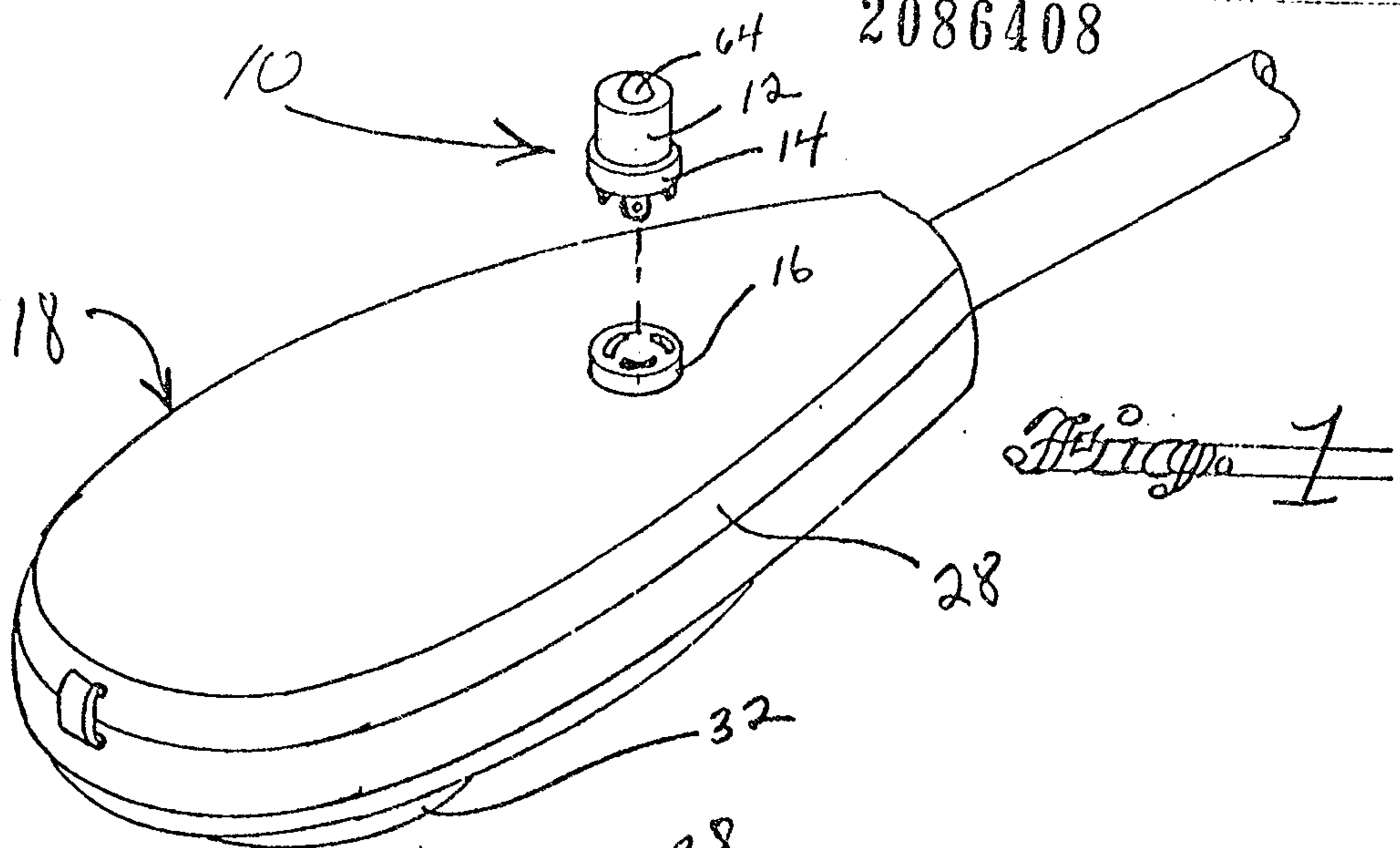

AGENTS: *Smart & Biggin*  
 INVENTOR: *FREDERICK H. BLAKE*

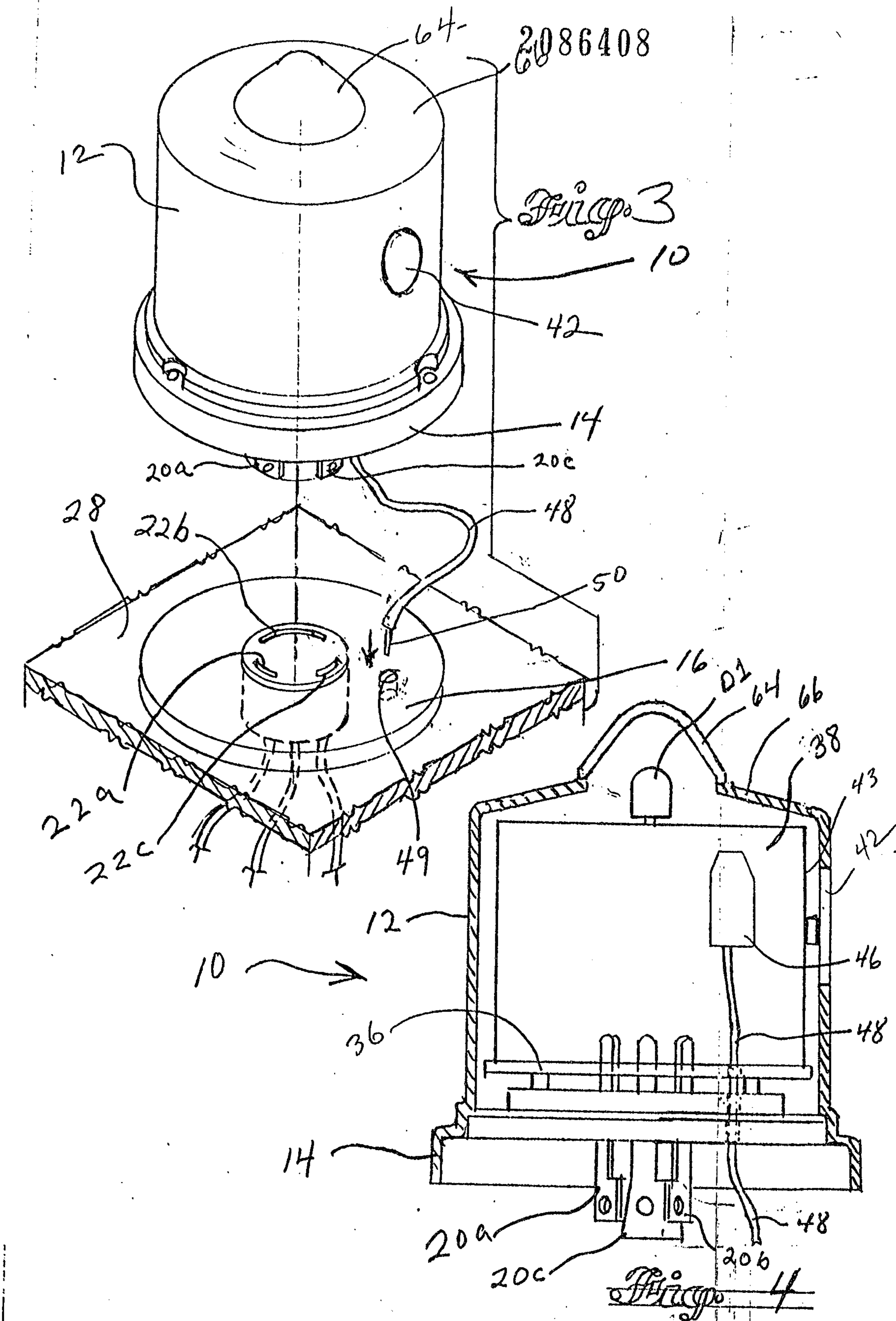

AGENTS: *Smart & Biggar*

INVENTOR: *FREDERICK H. BLAKE*

2086408

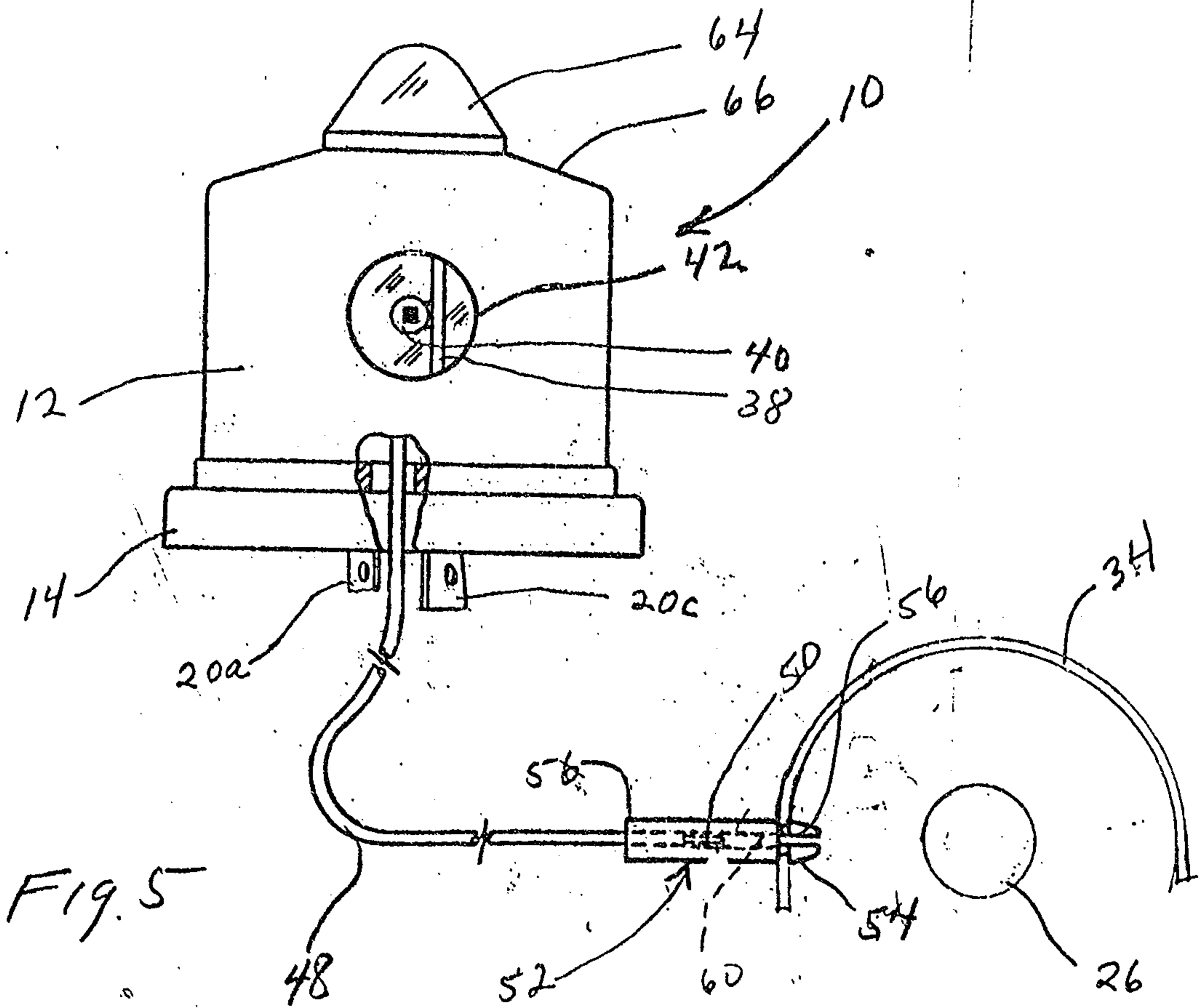

Fig. 5

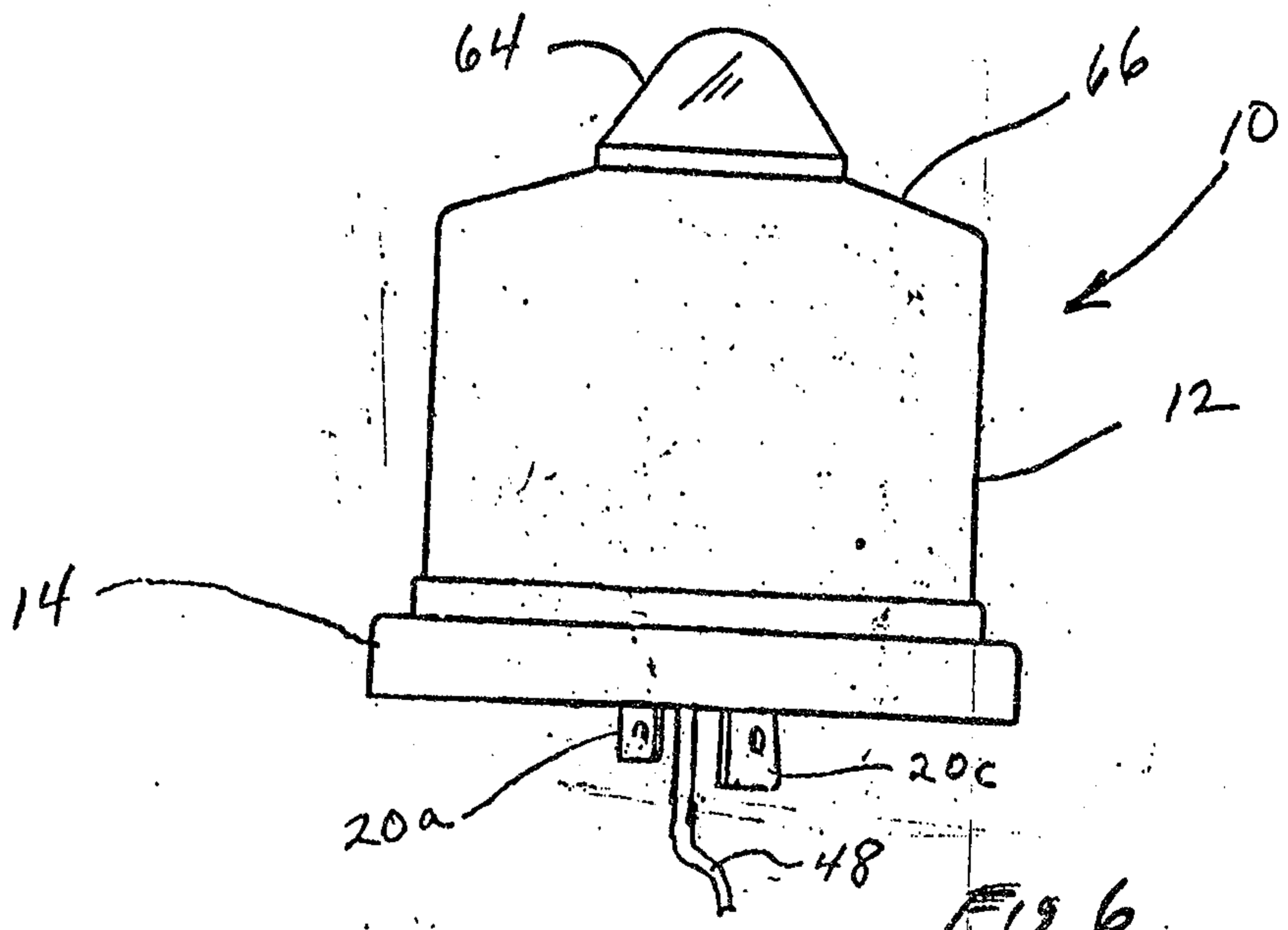

Fig. 6

AGENTS: Smart & Biggar  
INVENTOR: FREDERICK H. BLAKE

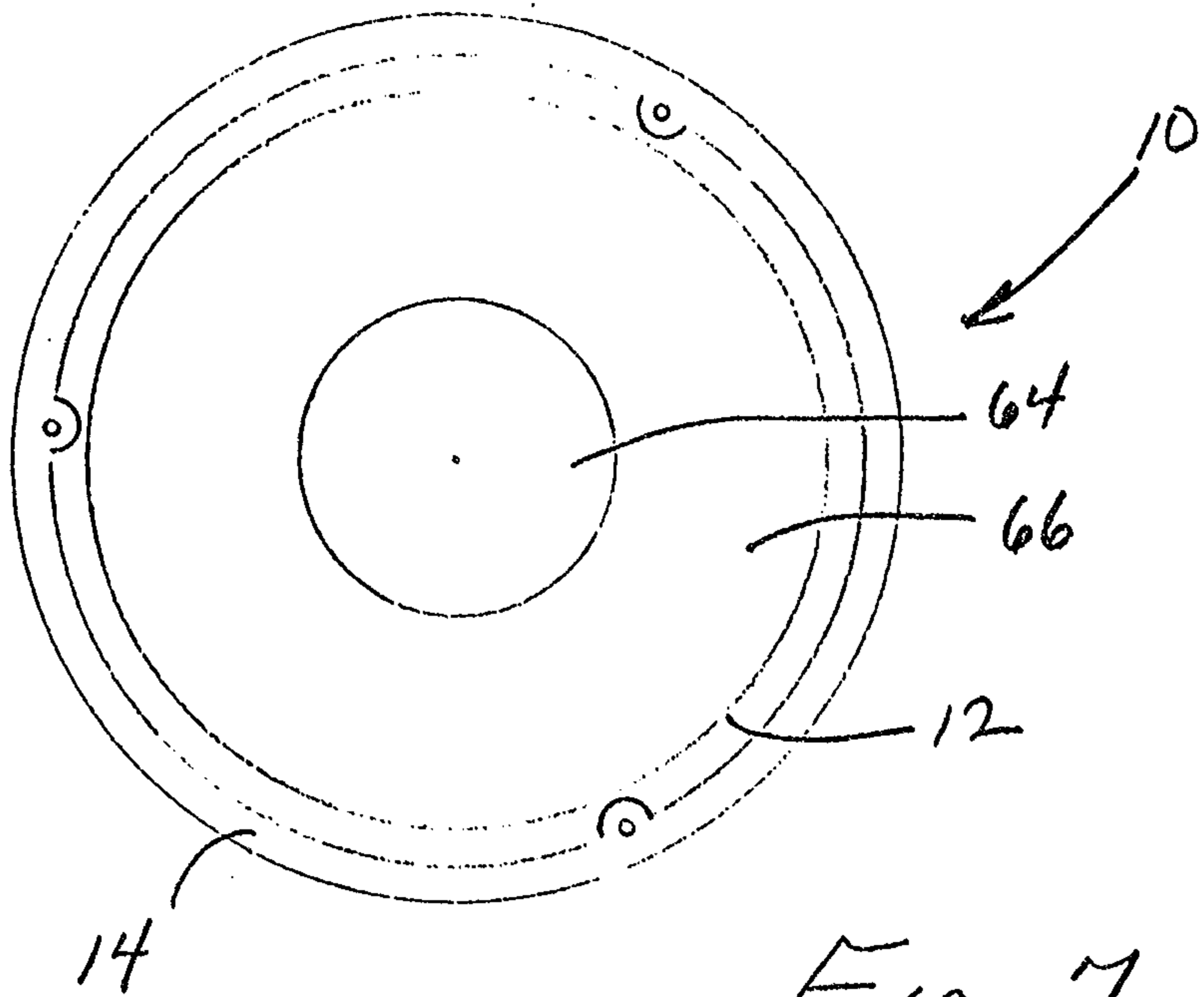

Fig. 7

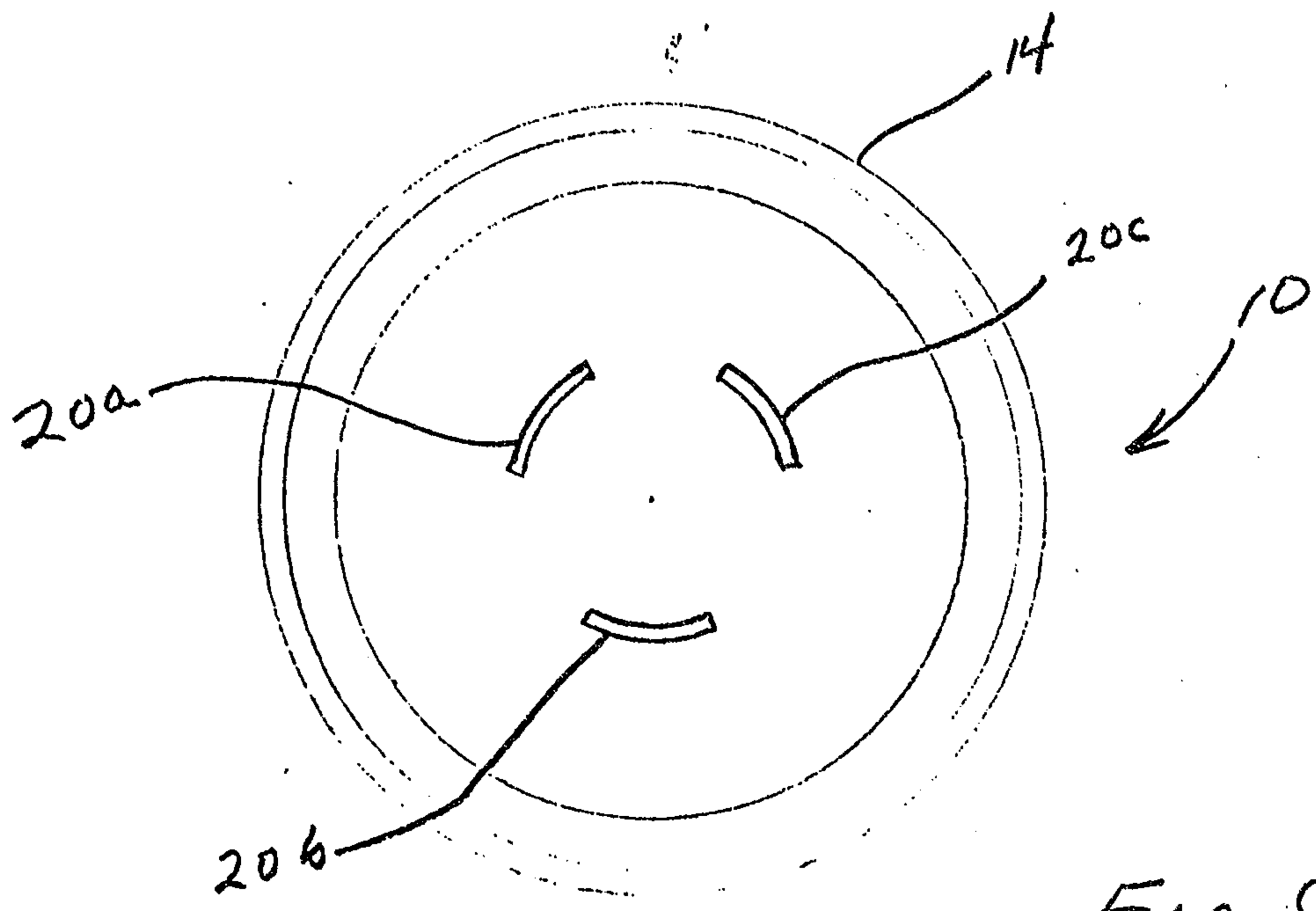

Fig. 8

AGENTS. Smart & Biggar  
INVENTOR: FREDERICK H. BLAKE

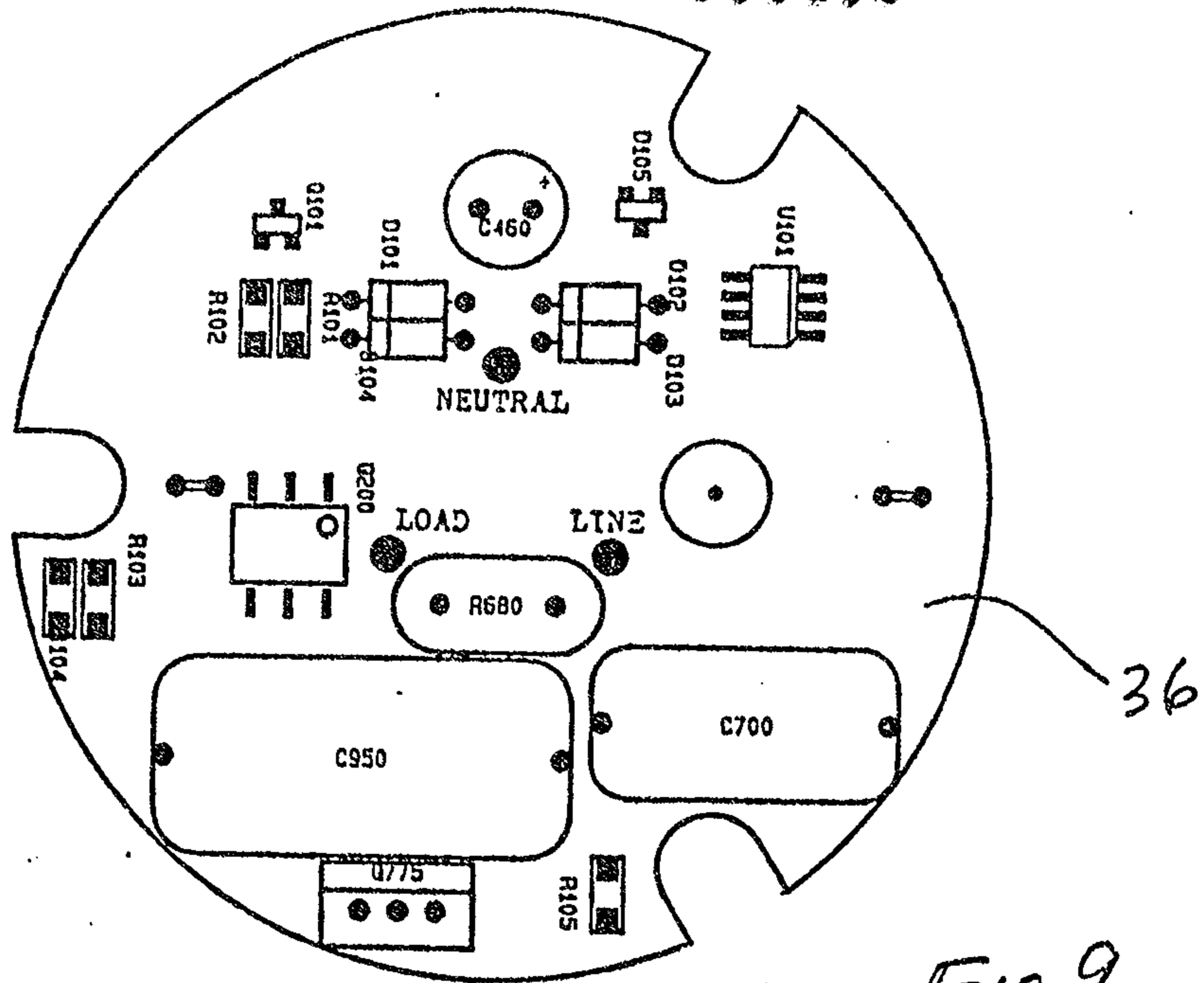

Fig. 9

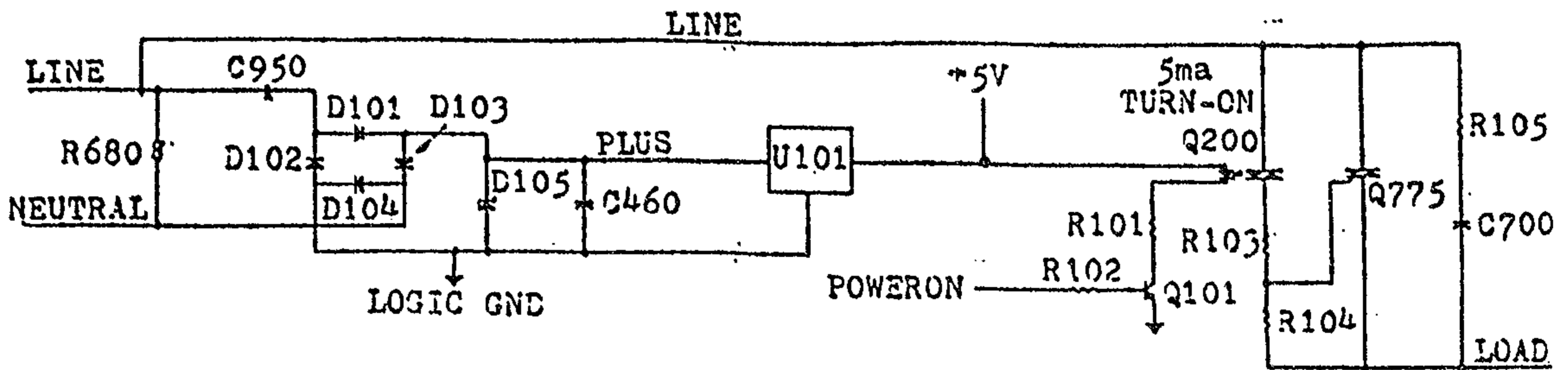

Fig. 10

AGENTS: Smart & Biggar  
 INVENTOR: FREDERICK H. BLAKE



