

Dec. 1, 1925.

1,563,627

G. N. HEIN

SYRINGE AMPUL, PISTON, AND PISTON PACKING CONSTRUCTION

Filed Dec. 23, 1924

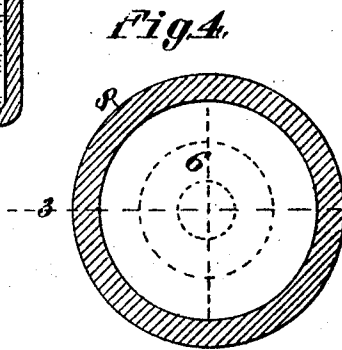
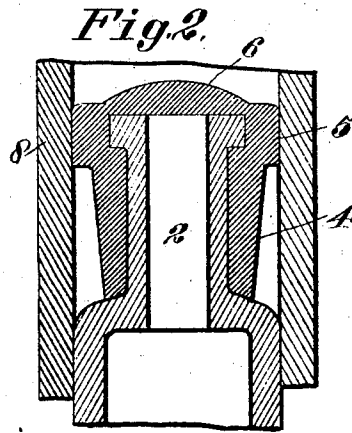
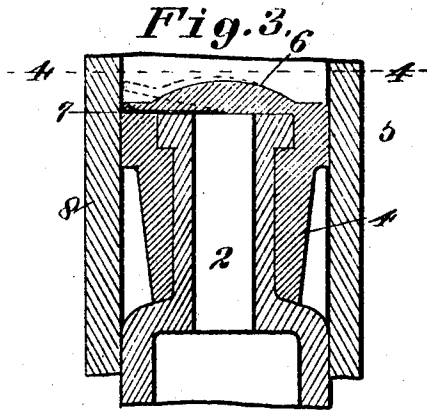
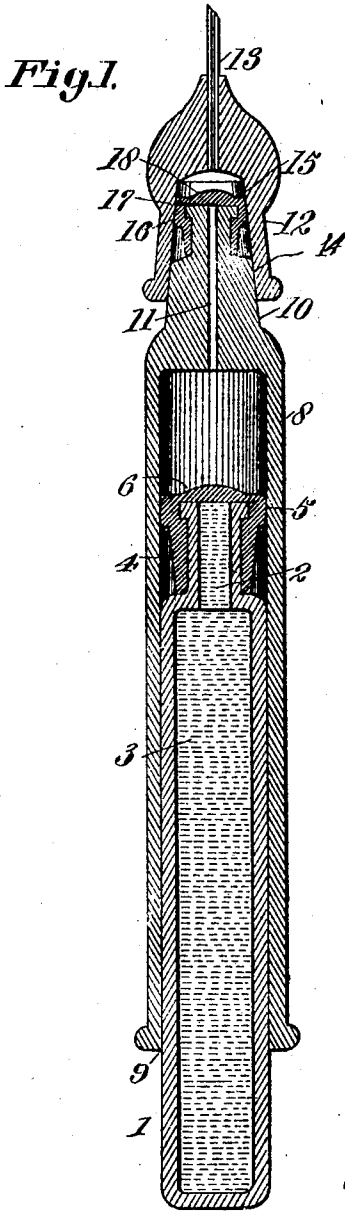

Inventor.

George H. Hein

By Harry A. Totten

Attorney

UNITED STATES PATENT OFFICE.

GEORGE N. HEIN, OF SAN FRANCISCO, CALIFORNIA.

SYRINGE AMPUL, PISTON, AND PISTON-PACKING CONSTRUCTION.

Application filed December 23, 1924. Serial No. 757,657.

To all whom it may concern:

Be it known that I, GEORGE N. HEIN, a citizen of the United States, residing at the city and county of San Francisco and State of California, have invented certain new and useful Improvements in Syringe Ampul, Piston, and Piston-Packing Constructions, of which the following is a specification.

This invention relates to a hypodermic syringe construction wherein the solution to be injected is adapted to be contained within a phial or ampul which is used as a piston within the syringe in filling the syringe and in ejecting the fluid therefrom.

This invention has a number of objects, among the principal being that a number of phials of the bottle type sterilized may be carried by the physician, with their outlets sealed by a hood designed for use as a piston plunger within a syringe barrel and adapted to be cut in such manner as to serve as a valve to admit of the withdrawing of the solution from the phial.

Another object is to employ the phial bottle as a piston and to construct the syringe proper with a valve member enabling the contents of the phial to be withdrawn on the rearward reciprocation of the piston and discharged on the forward movement of the piston, and to provide a simple form of elastic closure or hood for the container or phial, the peripheral edges of which are designed to snugly engage the inner surface of the syringe barrel and the top of which is adapted to be cut inwardly to provide a flap valve portion.

By the use of the present construction the desired quantity of the contents of the phial may be admitted into the syringe barrel and the remainder is adapted for subsequent use without exposure to the atmosphere and without admission into the syringe barrel until needed.

With the above mentioned and other objects in view, the invention consists in the novel construction and combination of parts hereinafter described, illustrated in the accompanying drawings and pointed out in the claims hereto appended; it being understood that various changes in the form, proportion, size and minor details of construction within the scope of the claims may be resorted to without departing from the spirit or sacrificing any of the advantages of the invention.

In the drawings, disclosing one embodiment of my invention—

Fig. 1 is a view in longitudinal section of a syringe barrel illustrating the phial inserted therein to be used as a piston.

Fig. 2 is a view in detail vertical section of the neck of the phial illustrating particularly the hooded closure prior to being cut and illustrating the same serving as a piston packing within the syringe barrel.

Fig. 3 is a view similar to Fig. 2, illustrating the phial closure cut inwardly from its outer edge providing a valve for controlling the discharge of the fluid from the phial.

Fig. 4 is a transverse sectional view on line 4—4 of Fig. 3.

In the drawings, wherein like characters of reference designate corresponding parts, 1 indicates a phial of the conventional cylindrical bottle type having a contracted neck 2, the phial adapted for containing suitable solution indicated by the numeral 3. The neck of the bottle or phial after being filled and preferably sterilized, is closed by a flexible hood 4 positioned over the neck, the hood preferably being constructed of rubber or other elastic material. Opposite the end of the bottle neck the peripheral edge of the hood 4 is of a diameter not less than that of the diameter of the phial 1 and is comparatively broad and flat affording a wide contact surface 5. That portion 6 of the hood 4 projecting beyond the end of the neck 2 is of considerable thickness in its center and tapers towards its edge.

Immediately prior to the bottle or phial being inserted neck end first into a syringe barrel hereinafter described, the user cuts the hood 4 inwardly from its outer edge to its center on a line parallel with the outer end of the bottle neck 2, as at 7, and this cut portion, as is illustrated in dotted lines—Fig. 3, when raised will permit of the escape of the contents from the end of the bottle or phial and when seated will preclude the entrance of fluid into the bottle and the peripheral wall 5 of the hood will contact with the inner wall of the barrel and serve as a piston head.

A syringe barrel 8 of the conventional type, preferably of glass, open at one end as at 9 and provided with a tapered nipple 10 at its opposite end, of an inside diameter substantially corresponding to the diameter

of the phial or bottle 1, is adapted to receive the latter. The end 10 is provided with an outlet channel 11 and said nipple mounts the base 12 carrying a hypodermic needle
 5 13. The reduced end 14 of the nipple then mounts a suitable hood 15, the peripheral edge 16 of which is in tight contact with the inner wall of the needle base, and the end of which is inwardly cut as at 17 to provide a flap valve portion 18 adapted to unseat on the inward reciprocation of the piston and to seat on the outward drawing of the same.

It will be observed that with the double valve construction one at the discharge end of the bottle or phial 1 and the other associated with the syringe, that the phial may be inserted into the barrel, after its hood has been cut, and on its inward movement will expel air from within the barrel, the expelled air passing through the channel 11 and escaping beyond the valve portion 18.

On the withdrawal or outward movement of the phial, the vacuum created within the syringe barrel will lift the cut portion 7, drawing the desired amount of fluid from the phial into the syringe barrel. On the syringe barrel being supplied with the necessary quantity of material dependent on the injection to be made, the further outward movement of the phial is arrested and the inward reciprocation thereof is made, causing a closing of the flap 7 and forcing the solution in the syringe barrel to raise the flap 18 and discharge from the needle 13.

It will be observed that the closure for the phial in addition to serving as a closure also serves as a piston head for the syringe barrel, and the cut flap portion serves as a valve; also that this construction enables the hypodermic injection of the desired solution from closed containers where the excess remains until entirely used.

I claim:—

45 1. A piston for hypodermic syringes including an elongated phial provided with

an outlet at one end, a yieldable closure therefor fitted over the end thereof and extending downwardly over the sides of the phial, said closure having a flap portion for frictionally engaging the syringe barrel wall and adapted for movement outwardly to admit of the discharge of the phial contents.

2. In combination with a hypodermic syringe barrel terminating at one end in a nipple and provided with a discharge opening, a needle mounting member carried by the nipple, a hood enclosing the nipple end and cut transversely of the nipple end to provide a valve for controlling the passage of fluid in one direction through the discharge opening, said needle mounting member engaging the nipple inwardly beyond the hood and frictionally engaging the hood at its point of greatest diameter, and a piston reciprocally mounted within the barrel.

3. In combination with a hypodermic syringe barrel terminating at one end in a nipple and provided with a discharge opening, a needle mounting member carried by the nipple, a flexible valve member and packing fitted over the end of the nipple for engagement by the needle mounting member and adapted to automatically control the passage of fluid in one direction through the discharge opening, and a piston reciprocally mounted within the barrel.

4. A piston head of elastic material for hollow piston rods of barrel syringes adapted to be placed over and surround the outlet end of the piston rod and bear against the piston rod barrel and serve as a packing, said piston head being provided with a valve controlling the outlet of the piston rod, said valve frictionally engaging the barrel wall to facilitate its opening and closing.

In testimony whereof I have signed my name to this specification.

GEORGE N. HEIN.