



(51) International Patent Classification:

E04F 13/08 (2006.01) E04F 15/10 (2006.01)
E04F 15/02 (2006.01) E04F 13/077 (2006.01)
E04F 15/06 (2006.01)

(21) International Application Number:

PCT/EP2020/078028

(22) International Filing Date:

07 October 2020 (07.10.2020)

(25) Filing Language:

English

(26) Publication Language:

English

(30) Priority Data:

LU101424 08 October 2019 (08.10.2019) LU

(71) Applicant: TARKETT GDL S.A. [LU/LU]; Z.I. Eselborn - Lentzweiler 2, op der Sang, L-9779 LENTZWEILER (LU).

(72) Inventors: KIRTIC, Srdjan; Tarkett d.o.o. Backa Palanka Industrijska zona 14, BACKA PALANKA, 21400 (RS).

BUGARCIC, Branko; Tarkett d.o.o. Backa Palanka Industrijska zona 14, BACKA PALANKA, 21400 (RS).

(74) Agent: BLOT, Philippe et al.; LAVOIX, 2, place d'Estienne d'Orves, 75441 PARIS CEDEX 09 (FR).

(81) Designated States (unless otherwise indicated, for every kind of national protection available): AE, AG, AL, AM, AO, AT, AU, AZ, BA, BB, BG, BH, BN, BR, BW, BY, BZ, CA, CH, CL, CN, CO, CR, CU, CZ, DE, DJ, DK, DM, DO, DZ, EC, EE, EG, ES, FI, GB, GD, GE, GH, GM, GT, HN, HR, HU, ID, IL, IN, IR, IS, IT, JO, JP, KE, KG, KH, KN, KP, KR, KW, KZ, LA, LC, LK, LR, LS, LU, LY, MA, MD, ME, MG, MK, MN, MW, MX, MY, MZ, NA, NG, NI, NO, NZ, OM, PA, PE, PG, PH, PL, PT, QA, RO, RS, RU, RW, SA, SC, SD, SE, SG, SK, SL, ST, SV, SY, TH, TJ, TM, TN, TR, TT, TZ, UA, UG, US, UZ, VC, VN, WS, ZA, ZM, ZW.

(84) Designated States (unless otherwise indicated, for every kind of regional protection available): ARIPO (BW, GH, GM, KE, LR, LS, MW, MZ, NA, RW, SD, SL, ST, SZ, TZ, UG, ZM, ZW), Eurasian (AM, AZ, BY, KG, KZ, RU, TJ, TM), European (AL, AT, BE, BG, CH, CY, CZ, DE, DK, EE, ES, FI, FR, GB, GR, HR, HU, IE, IS, IT, LT, LU, LV,

(54) Title: SET OF TILES TO COVER A SUPPORT SURFACE, AND ASSOCIATED COVER ELEMENT AND METHOD

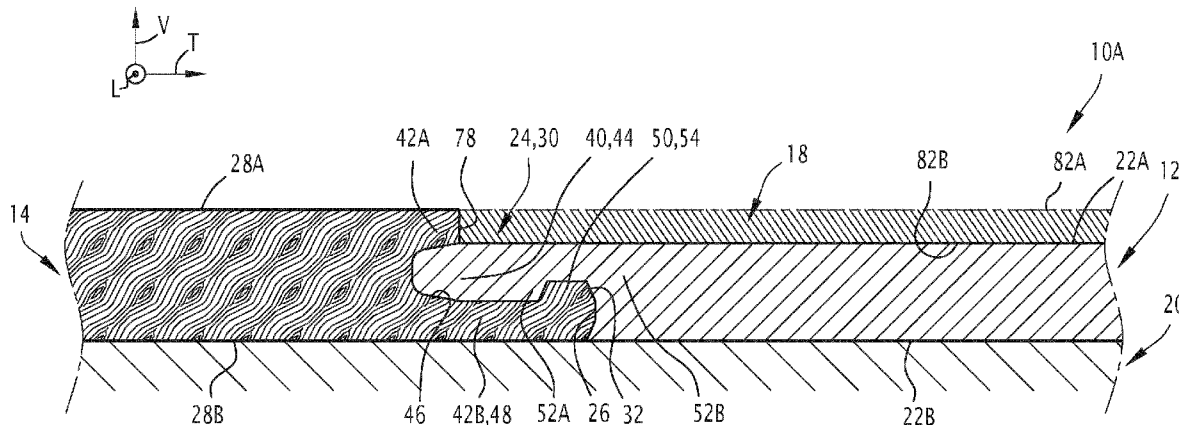

FIG. 1

(57) Abstract: The present invention concerns a set of tiles (10A) comprising: - a thin tile (12) defining a first connecting surface (26); - a thick tile (14) defining a second connecting surface (32), and having a thickness greater than a thickness of the thin tile. The first connecting surface (26) is adapted to engage the second connecting surface (32) in a locked configuration of the tiles, wherein the thick tile (14) is blocked in translation with respect to the thin tile (12) in a thickness direction (V) and in a transverse direction (T), and the set further comprises a cover layer (18) to be secured on the distal surface (22A) of the thin tile such that a distal surface (82A) of the cover layer (18) is flush with a distal surface (28A) of the thick tile.



MC, MK, MT, NL, NO, PL, PT, RO, RS, SE, SI, SK, SM,
TR), OAPI (BF, BJ, CF, CG, CI, CM, GA, GN, GQ, GW,
KM, ML, MR, NE, SN, TD, TG).

Published:

— *with international search report (Art. 21(3))*

Set of tiles to cover a support surface, and associated cover element and method

The present invention relates to a set of tiles adapted to cover a support surface perpendicular to a thickness direction of the tiles.

5 Such a support surface is for example a floor or a wall.

The present invention also deals with a corresponding method of covering such a surface.

Such tiles may have various shapes, such as rectangular or square.

10 When such two tiles have different thicknesses, ensuring a reliable and durable connection between them is difficult, in particular when they are in addition made of different materials.

Indeed, some gaps and clearances may appear between them.

Furthermore, the difference of thicknesses between the tiles is not aesthetic, and can lead to a risk of falling for a person walking on them.

15 An aim of the invention is to provide a set of tiles that allows improving the connection durability, reliability and aesthetic between the thin tile and thick tile, in particular when they are made of different materials, and preventing any risk of falling for the person walking on the tiles, while remaining simple to produce, and cost effective.

20 To this end, the invention proposes a set of tiles as described above, the set comprising:

- at least one thin tile defining a first connecting surface extending in a longitudinal direction perpendicular to the thickness direction, the thin tile extending, in the thickness direction, between a distal surface and a proximal surface with respect to the support surface;

25 - at least one thick tile defining a second connecting surface extending in the longitudinal direction, the thick tile having a thickness, in the thickness direction, greater than a thickness of the thin tile,

30 wherein the first connecting surface of the thin tile is adapted to matingly engage the second connecting surface of the thick tile in a locked configuration of the thin tile and the thick tile, wherein the thick tile is blocked in translation with respect to the thin tile in the thickness direction and in a transverse direction, the transverse direction being perpendicular to both the thickness direction and the longitudinal direction, and;

35 wherein the set further comprises a cover layer adapted to be secured on the distal surface of the thin tile such that a distal surface of the cover layer is flush with a distal surface of the thick tile.

In other embodiments, the set of tiles comprises one or several of the following features, taken in isolation or any technically feasible combination:

- the thin tile is made of a first material and the thick tile is made of a second material, the second material being different from the first material;

5 - in the locked configuration, one of the thin tile and the thick tile has a transverse locking region blocked, in the transverse direction, between two transverse framing regions of the other of the thin tile and the thick tile;

10 - the first and second connecting surfaces are configured such that, in the locked configuration, a blocking region of one of the thin tile and the thick tile is blocked, in the thickness direction, between a distal framing region and a proximal framing region of the other of the thin tile and the thick tile;

15 - one of the distal and proximal framing regions is lengthened, compared to the other of the distal and proximal framing regions, so as to form a base tongue transversally extending beyond the other of the distal and proximal framing regions, the base tongue defining a protrusion extending in the thickness direction, said transverse locking region being formed by the protrusion;

20 - the thick tile extends, in the thickness direction, between the distal surface and a proximal surface, the thick tile having a wall extending from its distal surface toward its proximal surface, and wherein the thin tile is adapted such that, in the locked configuration, the distal surface of the thin tile abuts against said wall and is recessed from the distal surface of the thick tile;

25 - the thick tile extends, in the thickness direction, between the distal surface and a proximal surface, the thick tile having a wall extending from its distal surface toward its proximal surface, and wherein the thick tile further has a connecting tongue (88) extending in the transverse direction from said wall, the thin tile being adapted such that, in the locked configuration, the distal surface of the thin tile is flush with a distal surface of the connecting tongue of the thick tile;

- the cover layer is adapted to abut against the wall of the thick tile;

30 - in the locked configuration, the first connecting surface and the second connecting surface are in continuous contact from the distal surface of the thin tile to the proximal surface of the thin tile;

- the thick tile extends, in the thickness direction, between the distal surface and a proximal surface, the proximal surface of the thin tile being flush with the proximal surface of the thick tile, in the locked configuration;

- the thin tile and the thick tile are in the locked configuration, the cover layer being secured to the distal surface of the thin tile such that the distal surface of the cover layer is flush with the distal surface of the thick tile.

5 In addition, the invention relates to a method of covering a support surface comprising:

- providing a set of tiles as defined above;
- assembling the thin tile and the thick tile in the locked configuration, the support surface being perpendicular to the thickness direction.

10 The invention and its advantages will be better understood upon reading the following description, given solely by way of example and with reference to the appended drawings, in which:

- Figure 1 is a schematic cross-sectional view of a set of tiles according to a first embodiment of the invention; and

15 - Figure 2 is a schematic cross-sectional view of a set of tiles according to a second embodiment of the invention.

A first embodiment of a set of tiles 10A according to the invention will now be described with reference to Figure 1.

The set 10A comprises at least one thin tile 12 and at least one thick tile 14.

The set 10A further comprises a cover layer 18.

20 The set 10A comprises advantageously a plurality of other tiles.

The set 10A comprises for example a plurality of other thin tiles, substantially identical to the thin tile 12 illustrated in Figure 1, the thin tiles being adapted to be connected directly to each other.

25 The set 10A further comprises for example a plurality of other thick tiles 14, substantially identical to the thick tile 14 illustrated in Figure 1, the thick tiles 14 being adapted to be connected directly to each other.

The set 10A is adapted to cover a support surface 20, which is substantially perpendicular to a thickness direction V of the tiles.

30 Each tile 12, 14 are further defined with respect to a longitudinal direction L, perpendicular to the thickness direction V, and with respect to a transverse direction T, perpendicular to both the thickness direction V and the longitudinal direction L.

The thickness direction V is vertical in Figure 1.

The support surface 20 is in the example of Figure 1 a floor. In a variant (not shown), the support surface 20 is defined by a ceiling or a wall.

35 The thin tile 12 extends, in the thickness direction V, between a distal surface 22A and a proximal surface 22B.

Here and in the following, “distal” means “away from the support surface” in the thickness direction V. In addition, “proximal” means “toward the support surface” in the thickness direction V.

5 Thus, when the set 10A covers the support surface 20, the proximal surface 22B of the thin tile 12 is opposite the support surface 20 and for example in contact with the support surface 20.

The distal surface 22A of the thin tile 12 is preferably parallel to the proximal surface 22B of the thin tile 12.

10 The thin tile 12 has a first longitudinal edge 24 extending in the longitudinal direction L.

The thin tile 12 defines a first connecting surface 26 extending in the longitudinal direction L.

The first connecting surface 26 is formed by the first longitudinal edge 24 of the thin tile 12.

15 The thin tile 12 has a thickness, in the thickness direction V, for example comprised between 3 mm and 12 mm. The thickness is here and in the following defined as the distance between the distal and proximal surfaces.

The thin tile 12 is made of a first material.

In the example of Figure 1, the first material is a laminate.

20 The thin tile 12 comprises advantageously one or several distal layer(s) (not shown in Figure 1). The distal layer(s) for example comprise(s) a decorative layer located on the first material and/or a wear layer, located on the decorative layer if any.

The thick tile 14 extends, in the thickness direction V, between a distal surface 28A and a proximal surface 28B.

25 Thus, when the set 10A covers the support surface 20, the proximal surface 28B of the thick tile 14 is for example in contact with the support surface 20.

The distal surface 28A of the thick tile 14 is preferably parallel to the proximal surface 28B of the thick tile 14.

30 The thick tile 14 has a second longitudinal edge 30 extending in the longitudinal direction L.

The second longitudinal edge 30 of the thick tile 14 has advantageously the same length as the first longitudinal edge 24 of the thin tile 12. By “length of an element”, it is meant the distance, in projection on the longitudinal direction L, between the two most opposite points of the element.

35 The thick tile 14 defines a second connecting surface 32 extending in the longitudinal direction L.

The second connecting surface 32 is formed by the second longitudinal edge 30.

The thick tile 14 has a thickness, in the thickness direction, greater than the thickness of the thin tile 12.

In an example, the difference between the thicknesses of the thin and thick tiles 12, 14 is, for example, longer than 10 % of the thickness of the thin tile.

The thickness of the thick tile 14 is for example comprised between 4 mm and 14 mm.

The thick tile 14 is made of a second material.

The second material is for example different from the first material of the thin tile 12.

The second material is a core layer made, in the example of Figure 1, of wood. Alternatively, the thick tile 14 is made of another material.

The thick tile 14 advantageously comprises one or several distal layer(s) (not shown in Figure 1). The distal layer(s) for example comprise(s) a decorative layer located on the second material and/or a wear layer, located on the decorative layer if any.

The thin tile 12 and the thick tile 14 are adapted to be directly and rigidly connected to each other.

In particular, when the thin tile 12 and the thick tile 14 are connected to each other, they are in contact with one another.

Advantageously, the respective profiles of the first and second connecting surfaces 26, 32 are substantially the same along the longitudinal direction L.

In that view, the first connecting surface 26 of the thin tile 12 is adapted to matingly engage the second connecting surface 32 of the thick tile 14 in a locked configuration of the thin tile 12 and the thick tile 14.

The thin tile 12 and the thick tile 14 are adapted to be moved, preferably in a reversible manner, from a configuration in which they are disposed away from each other to the locked configuration.

The locked configuration is illustrated in Figure 1.

More specifically, the first connecting surface 26 of the thin tile 12 is defined as the surface of the thin tile 12 extending, in a section perpendicular to the longitudinal direction L, between the most distal contact point and the most proximal contact point with the thick tile 14, in the locked configuration.

The first connecting surface 26 of the thin tile 12 preferably extends from the distal surface 22A of the thin tile 12 to the proximal surface 22B of the thin tile 12.

Thus, by "the first connecting surface 26 is adapted to matingly engage the second connecting surface 32", it is meant that at least parts of the first connecting surface 26 and the second connecting surface 32 closely match with each other.

In the locked configuration, the first connecting surface 26 and the second connecting surface 32 are preferably in continuous contact from the distal surface 22A of the thin tile 12 to the proximal surface 22B of the thin tile 12. In this case, all of the first connecting surface 26 closely match with the second connecting surface 32.

5 In the locked configuration, the distal and proximal surfaces 22A, 22B of the thin tile 12 are preferably parallel to the distal and proximal surfaces 28A, 28B of the thick tile 14.

Moreover, in the locked configuration, the proximal surface 22B of the thin tile 12 is, in this example, flush with the proximal surface 28B of the thick tile 14.

10 In the locked configuration, any translation movement of the thin tile 12 with respect to the thick tile 14 is blocked in the thickness direction V and in the transverse direction T.

Similarly, in the locked configuration, any translation movement of the thick tile 14 with respect to the thin tile 12 is blocked in the thickness direction V and in the transverse direction T.

15 In order to allow locking of the tiles 12, 14 in the thickness direction V, in the example of Figure 1, the first connecting surface 26 and the second connecting surface 32 are configured such that, in the locked configuration, a blocking region 40 of the thin tile 12 is blocked, in the thickness direction V, between a distal framing region 42A of the thick tile 14 and a proximal framing region 42B of the thick tile 14.

20 In particular, in a plan perpendicular to the transverse direction T, the blocking region 40 is disposed between the distal framing region 42A and the proximal framing region 42B.

In Figure 1, this blocking region 40 of the thin tile 12 is delimited by the first connecting surface 26 and is formed by a connecting tongue 44 extending along the transverse direction T.

25 As illustrated in Figure 1, the distal and proximal framing regions 42A, 42B of the thick tile 14 are delimited by the second connecting surface 32 and are formed by a connecting groove 46 arranged in the thick tile 14.

In particular, the connecting groove 46 of the thick tile 14 has a base, which is the most recessed part of the connecting groove 46, in the transverse direction.

30 In addition, the proximal framing region 42B is lengthened, compared to the distal framing region 42A, so as to form a base tongue 48 extending, in the transverse direction T, beyond the distal framing region 42A.

The base tongue 48 partly defines the proximal surface 28B of the thick tile 14.

35 Preferably, as illustrated in figure 1, the locking of the tiles 12, 14 in the thickness direction V is reinforced.

In particular, in the locked configuration, a region of the base tongue 48 is blocked, in the thickness direction V, between two other regions of the thin tile 12. In a plan perpendicular to the transverse direction T, said region of the base tongue 48 is disposed between said other regions of the thin tile 12.

5 In order to allow locking of the tiles 12, 14 in the transverse direction T, in the example of Figure 1, the thin tile 12 and the thick tile 14 are configured such that, in the locked configuration, a transverse locking region 50 of the thick tile 14 is blocked, in the transverse direction T, between two transverse framing regions 52A, 52B of the thin tile 12.

10 In particular, in a plan perpendicular to the thickness direction V, the transverse locking region 50 is disposed between the transverse framing regions 52A, 52B.

To that end, in Figure 1, the base tongue 48 of the thick tile 14 defines a protrusion 54 extending in the thickness direction V and the first connecting surface 26 defines a corresponding recess.

15 This protrusion 54 extends toward the distal surface 28A of the thick tile 14.

The transverse locking region 50 of the thick tile 14 is delimited by the second connecting surface 32 and is formed by the protrusion 54.

In addition, the transverse framing regions 52A, 52B of the thin tile 12 are delimited by the first connecting surface 26 and are formed by the corresponding recess.

20 In a preferred embodiment of the invention, illustrated in Figure 1, the thick tile 14 further has a wall 78 extending from its distal surface 28A toward its proximal surface 28.

In particular, this wall 78 extends down to the connecting groove 64 of the thick tile 14.

For example, this wall 78 is defined by the core layer of the thick tile 14 if any.

25 The wall 78 is preferably straight and extends for example perpendicularly to the distal surface 28A of the thick tile 14.

The thin tile 12 is adapted such that, in the locked configuration, the distal surface 22A of the thin tile 12 abuts against said wall 78.

30 In the example of Figure 1, the thin tile 12 abuts against a point of the thick tile 14 connecting the wall 78 of the thick tile 14 to the connecting groove 64 of the thick tile 14, in a section perpendicular to the longitudinal direction L.

The cover layer 18 of the set 10A is adapted to be applied on the distal surface 22A of the thin tile 12, in an assembled configuration of the thin tile 12, of the thick tile 14 and of the cover layer 18.

35 The cover layer 18 extends, in the thickness direction V, between a distal surface 82A and a proximal surface 82B.

The proximal surface 82B of the cover layer 18 is adapted to be in contact with the distal surface 22A of the thin tile 12, in the assembled configuration.

The cover layer 18 is preferably adapted to be secured, for example by gluing, to the distal surface of the thin tile 12, in the assembled configuration.

5 The cover layer 18 is adapted to abut against the wall 78 of the thick tile 14, in the assembled configuration.

In the assembled configuration, the distal surface 82A of the cover layer 18 is flush with the distal surface 28A of the thick tile 14.

10 The cover layer 18 is made of a third material, for example different from the first and second material of the thin and thick tiles 12, 14.

The cover layer 18 is for example a decorative layer.

In view of the above, when the thin tile 12 and the thick tile 14 are in the locked configuration, a cover element according to the invention is obtained.

15 The cover element comprises advantageously the cover layer 18 in the assembled configuration.

The cover element is then adapted to cover the support surface 20, and preferably to be secured to the support surface 20.

A method of covering the support surface 20 with a set 10A according to the first embodiment of the invention will now be described.

20 The method comprises providing a set 10A of tiles as disclosed above.

The method further comprises assembling the tiles 12, 14 in the locked configuration.

The cover element is thus obtained and is applied to the support surface 20.

The cover element is advantageously secured to the support surface 20.

25 The method comprises also for example a step of applying and preferably securing the cover layer 18 to the distal surface of the thin tile 12.

The cover layer 18 abuts against the wall 78 of the thick tile 14, the distal surface 82A of the cover layer 18 being preferably flush with the distal surface 28A of the thick tile 14.

30 In an alternative of the above method, at least one of the tiles 12, 14 is applied, and preferably secured, to the support surface 20 before the step of assembling the tiles 12, 14 in the locked configuration.

When the cover element is obtained, it is thus already applied on the support surface 20.

35 Some alternatives to the set of tiles 10A according to the first embodiment will now be described.

In an alternative, the second longitudinal edge 30 of the thick tile 14 has a different length from the first longitudinal edge 24 of the thin tile 12.

In a variant, the thin tile 12 is made of a different material than a laminate. The first material of the thin tile 12 is then a core layer made for example of a thermoplastic material, wood, or metal.

In another variant, the second material of the thick tile 14 is for example a laminate.

A second embodiment of the set of tiles 10B according to the invention will now be described in reference to Figure 2.

Only the differences between the first and the second embodiments will be described below.

The locking of the thin tile 12 with respect to the thick tile 14 in the thickness direction V and the transverse direction V is obtained in a different manner in the second embodiment, compared to the first embodiment.

In the example of Figure 2, in order to allow locking of the tiles 12, 14 in the thickness direction V, the first connecting surface 26 and the second connecting surface 32 are configured such that, in the locked configuration, a blocking region 84 of the thick tile 14 is blocked, in the thickness direction V, between a distal framing region 86A of the thin tile 12 and a proximal framing region 86B of the thin tile 12.

In particular, in a plan perpendicular to the transverse direction T, the blocking region 84 is disposed between the distal framing region 86A and the proximal framing region 86B.

In Figure 2, this blocking region 84 of the thick tile 14 is delimited by the second connecting surface 32 and is formed by a connecting tongue 88 extending along the transverse direction T.

In the second embodiment, the connecting tongue 88 of the thick tile 14 extends in the transverse direction T from the wall 78 of the thick tile 14.

The connecting tongue 88 of the thick tile 14 has a distal surface 108 sensibly parallel to the distal surface 28A of the thick tile 14.

The distal surface 108 of the connecting tongue 88 is closer to the proximal surface 28B of the thick tile 14 than to the distal surface 28A of the thick tile 14.

The wall 78 of the thick tile 14 connects the distal surface 28A of the thick tile 14 to the distal surface 108 of the connecting tongue 88 of the thick tile 14.

As illustrated in Figure 2, the distal and proximal framing regions 86A, 86B of the thin tile 12 are delimited by the first connecting surface 26 and are formed by a connecting groove 90 arranged in the thin tile 12.

In particular, the connecting groove 90 of the thin tile 12 has a base 92, which is the most recessed part of the connecting groove 90 of the thin tile 12, in the transverse direction.

5 In addition, the proximal framing region 86B of the thin tile 12 is lengthened, compared to the distal framing region 86A, so as to form a base tongue 94 extending in the transverse direction T beyond the distal framing region 86A.

The base tongue 94 of the thin tile 12 partly defines the proximal surface 22B of the thin tile 12.

10 In order to allow locking of the tiles 12, 14 in the transverse direction T, in the example of Figure 2, the thin tile 12 and the thick tile 14 are configured such that, in the locked configuration, a transverse locking region 96 of the thin tile 12 is blocked, in the transverse direction T, between two transverse framing regions 98A, 98B of the thick tile 14.

15 In particular, in a plan perpendicular to the thickness direction V, the transverse locking region 96 is disposed between the transverse framing regions 98A, 98B.

To that end, in Figure 2, the base tongue 94 of the thin tile 12 defines a protrusion 100 extending in the thickness direction V and the second connecting surface 32 defines a corresponding recess.

This protrusion 100 extends toward the distal surface 22A of the thin tile 12.

20 The transverse locking region 96 of the thin tile 12 is delimited by the second connecting surface 32 and is formed by the protrusion 100.

In addition, the transverse framing regions 98A, 98B of the thick tile 14 are delimited by the second connecting surface 32, and are formed by the corresponding recess.

25 In addition to the above, in the second embodiment, the thin tile 12 is adapted such that, in the locked configuration, the distal surface 22A of the thin tile 12 is flush with the distal surface 108 of the connecting tongue 88 of the thick tile 14.

Thus, the thin tile 12 does not abut against the wall 78 of the thick tile 14 in the second embodiment.

30 In the assembled configuration of the thin tile 12, of the thick tile 14 and of the cover layer 18, the cover layer 18 is further adapted to be applied on the distal surface 108 of the connecting tongue 88 of the thick tile 14.

A method of covering the support surface 20 with a set 10B according to the second embodiment of the invention will now be described.

This method is sensibly identical to the one described above.

In an alternative not shown in figure 2, in the locked configuration, a region of the base tongue 94 of the thin tile 12 is blocked, in the thickness direction V, between two other regions of the thick tile 14.

5 Thanks to the above disclosed features, it is possible to ensure a reliable and direct connection between the thin tile 12 and the thick tile 14.

In addition, thanks to the cover layer 18, the difference of thicknesses between the tiles 12, 14 is not noticeable to a person walking on the assembled set of tiles.

The risk of falling for this person is therefore dramatically reduced.

10 The connection between the thin tile 12 and the thick tile 14 remains nevertheless simple to produce, and cost effective.

CLAIMS

1.- A set of tiles (10A; 10B) adapted to cover a support surface (20) perpendicular to a thickness direction (V) of the tiles, the set (10A; 10B) comprising:

5 - at least one thin tile (12) defining a first connecting surface (26) extending in a longitudinal direction (L) perpendicular to the thickness direction (V), the thin tile (12) extending, in the thickness direction (V), between a distal surface (22A) and a proximal surface (22B) with respect to the support surface (20);

10 - at least one thick tile (14) defining a second connecting surface (32) extending in the longitudinal direction (L), the thick tile (14) having a thickness, in the thickness direction (V), greater than a thickness of the thin tile (12),

15 wherein the first connecting surface (26) of the thin tile (12) is adapted to matingly engage the second connecting surface (32) of the thick tile (14) in a locked configuration of the thin tile (12) and the thick tile (14), wherein the thick tile (14) is blocked in translation with respect to the thin tile (12) in the thickness direction (V) and in a transverse direction (T), the transverse direction (T) being perpendicular to both the thickness direction (V) and the longitudinal direction (L), and;

20 wherein the set further comprises a cover layer (18) adapted to be secured on the distal surface (22A) of the thin tile (12) such that a distal surface (82A) of the cover layer (18) is flush with a distal surface (28A) of the thick tile (14).

25 2.- The set (10A; 10B) according to claim 1, wherein the thin tile (12) is made of a first material and the thick tile (14) is made of a second material, the second material being different from the first material.

30 3.- The set (10A; 10B) according to any one of claims 1 or 2, wherein, in the locked configuration, one of the thin tile (12) and the thick tile (14) has a transverse locking region (50, 96) blocked, in the transverse direction (T), between two transverse framing regions (52A, 52B, 98A, 98B) of the other of the thin tile (12) and the thick tile (14).

35 4.- The set (10A; 10B) according to any one of claims 1 to 3, wherein the first and second connecting surfaces (26, 32) are configured such that, in the locked configuration, a blocking region (40; 84) of one of the thin tile (12) and the thick tile (14) is blocked, in the thickness direction (V), between a distal framing region (42A; 86A) and a proximal framing region (42B; 86B) of the other of the thin tile (12) and the thick tile (14).

5 5.- The set (10A; 10B) according to claim 4, in combination with claim 3, wherein one of the distal and proximal framing regions (42B; 86B) is lengthened, compared to the other of the distal and proximal framing regions (42A; 86A), so as to form a base tongue (48; 94) transversally extending beyond the other of the distal and proximal framing regions (42A; 86A), the base tongue (48; 94) defining a protrusion (54; 100) extending in the thickness direction (V), said transverse locking region (50, 96) being formed by the protrusion (54; 100).

10 6.- The set (10A) according to any one of claims 1 to 5, wherein the thick tile (14) extends, in the thickness direction (V), between the distal surface (28A) and a proximal surface (28B), the thick tile (14) having a wall (78) extending from its distal surface (28A) toward its proximal surface (28B), and wherein the thin tile (12) is adapted such that, in the locked configuration, the distal surface (22A) of the thin tile (12) abuts against said wall (78) and is recessed from the distal surface (28A) of the thick tile (14).

15 7.- The set (10B) according to any one of claims 1 to 5, wherein the thick tile (14) extends, in the thickness direction (V), between the distal surface (28A) and a proximal surface (28B), the thick tile (14) having a wall (78) extending from its distal surface (28A) toward its proximal surface (28B), and wherein the thick tile (14) further has a connecting tongue (88) extending in the transverse direction (T) from said wall (78), the thin tile (12) being adapted such that, in the locked configuration, the distal surface (22A) of the thin tile (12) is flush with a distal surface (108) of the connecting tongue (88) of the thick tile (14).

20 8.- The set (10A; 10B) according to any one of claims 6 or 7, wherein the cover layer (18) is adapted to abut against the wall (78) of the thick tile (14).

30 9.- The set (10A; 10B) according to any one of claims 1 to 8, wherein, in the locked configuration, the first connecting surface (26) and the second connecting surface (32) are in continuous contact from the distal surface (22A) of the thin tile (12) to the proximal surface (22B) of the thin tile (12).

35 10.- The set (10A; 10B) according to any one of claims 1 to 9, wherein the thick tile (14) extends, in the thickness direction (V), between the distal surface (28A) and a proximal surface (28B), the proximal surface (22B) of the thin tile (12) being flush with the proximal surface (28B) of the thick tile (14), in the locked configuration.

11.- The set (10A; 10B) according to any one of claims 1 to 10, wherein the thin tile (12) and the thick tile (14) are in the locked configuration, the cover layer (18) being secured on the distal surface (22A) of the thin tile (12) such that the distal surface (82A) of the cover layer (18) is flush with the distal surface (28A) of the thick tile (14).

5

12.- A method of covering a support surface (20) comprising:

- providing a set of tiles (10A; 10B) according to any one of claims 1 to 11;
- assembling the thin tile (12) and the thick tile (14) in the locked configuration, the support surface (20) being perpendicular to the thickness direction (V).

10

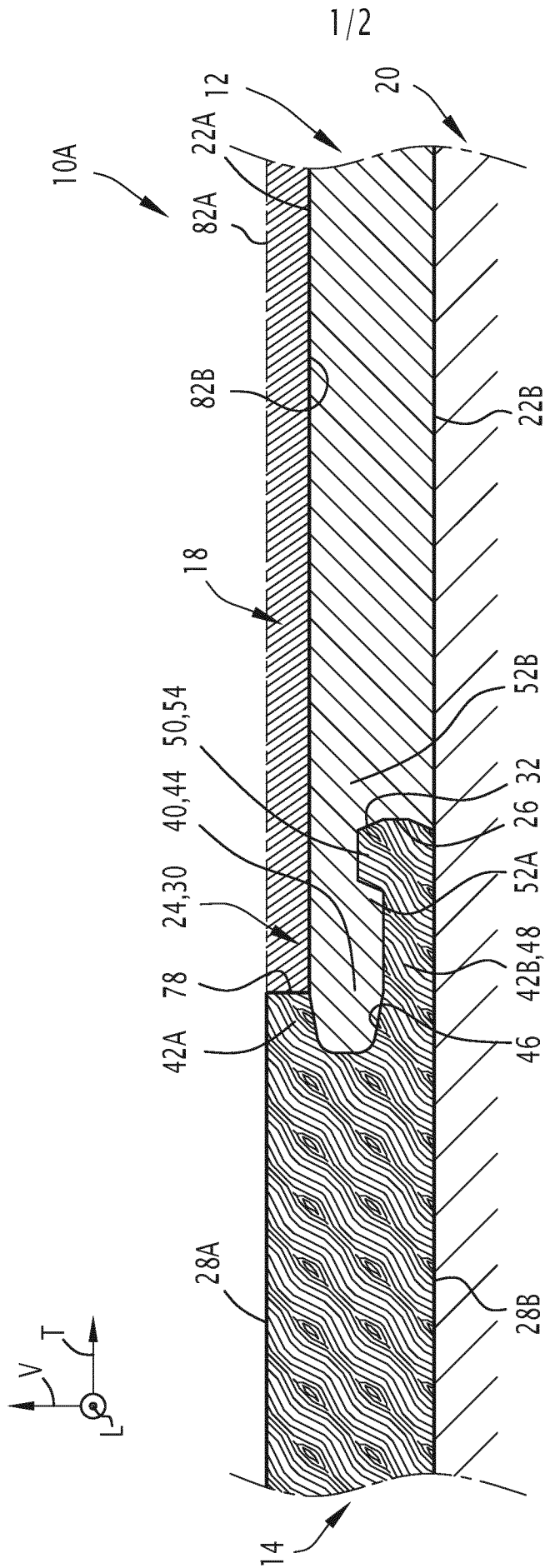
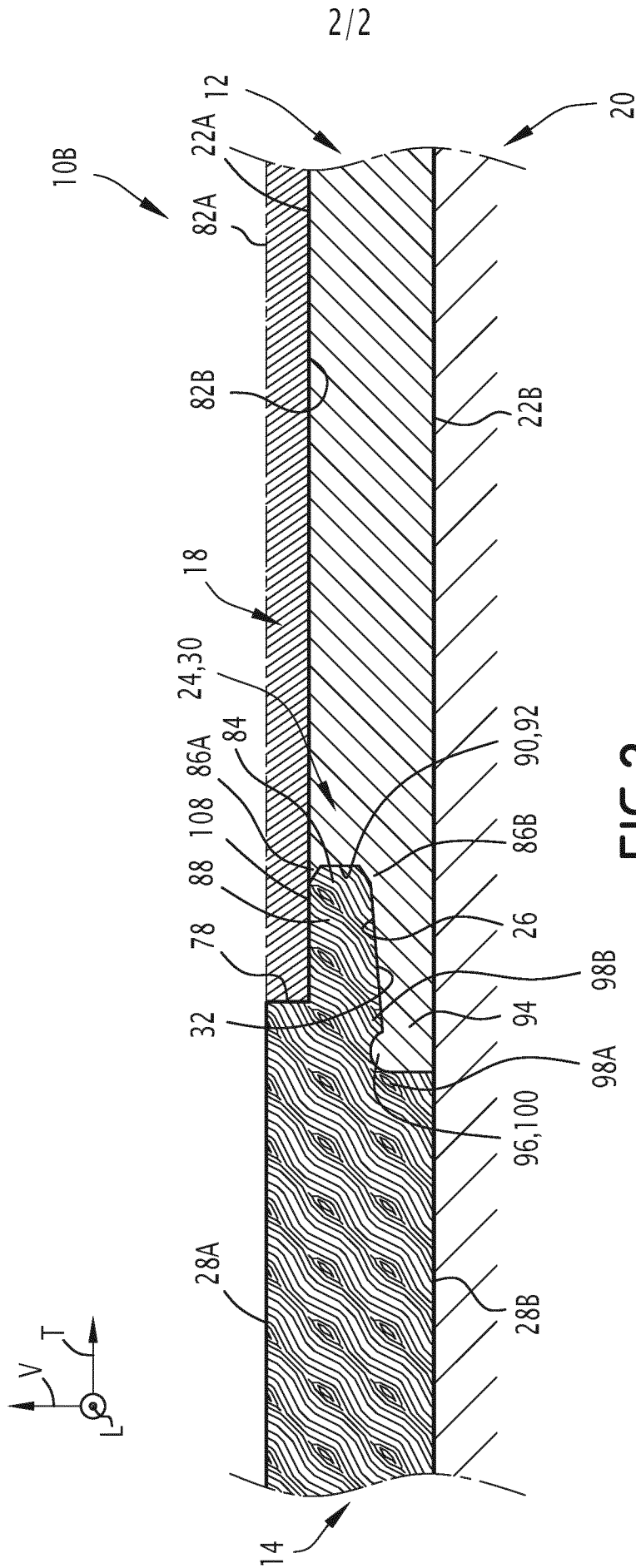

FIG.1



INTERNATIONAL SEARCH REPORT

International application No
PCT/EP2020/078028

A. CLASSIFICATION OF SUBJECT MATTER
INV. E04F13/08 E04F15/02 E04F15/06 E04F15/10 E04F13/077
ADD.
According to International Patent Classification (IPC) or to both national classification and IPC

B. FIELDS SEARCHED
Minimum documentation searched (classification system followed by classification symbols)
E04F

Documentation searched other than minimum documentation to the extent that such documents are included in the fields searched

Electronic data base consulted during the international search (name of data base and, where practicable, search terms used)
EPO-Internal

C. DOCUMENTS CONSIDERED TO BE RELEVANT

Category*	Citation of document, with indication, where appropriate, of the relevant passages	Relevant to claim No.
X	WO 2004/074597 A1 (VAELINGE INNOVATION AB [SE]; PERVAN DARKO [SE]) 2 September 2004 (2004-09-02)	1-6,8, 10-12
A	page 17, paragraph 2 - page 18, paragraph 1; figures 5a, 5b page 19, paragraph 2; figure 7a -----	7,9
A	EP 3 530 840 A1 (CHAMPION LINK INT CORPORATION [AI]) 28 August 2019 (2019-08-28) figures 2 and 3 and relating description -----	7

Further documents are listed in the continuation of Box C.

See patent family annex.

* Special categories of cited documents :

- "A" document defining the general state of the art which is not considered to be of particular relevance
- "E" earlier application or patent but published on or after the international filing date
- "L" document which may throw doubts on priority claim(s) or which is cited to establish the publication date of another citation or other special reason (as specified)
- "O" document referring to an oral disclosure, use, exhibition or other means
- "P" document published prior to the international filing date but later than the priority date claimed

- "T" later document published after the international filing date or priority date and not in conflict with the application but cited to understand the principle or theory underlying the invention
- "X" document of particular relevance; the claimed invention cannot be considered novel or cannot be considered to involve an inventive step when the document is taken alone
- "Y" document of particular relevance; the claimed invention cannot be considered to involve an inventive step when the document is combined with one or more other such documents, such combination being obvious to a person skilled in the art
- "&" document member of the same patent family

Date of the actual completion of the international search 27 November 2020	Date of mailing of the international search report 08/12/2020
---	--

Name and mailing address of the ISA/ European Patent Office, P.B. 5818 Patentlaan 2 NL - 2280 HV Rijswijk Tel. (+31-70) 340-2040, Fax: (+31-70) 340-3016	Authorized officer Warthmüller, Almut
--	--

INTERNATIONAL SEARCH REPORT

Information on patent family members

International application No

PCT/EP2020/078028

Patent document cited in search report	Publication date	Patent family member(s)	Publication date
WO 2004074597	A1	02-09-2004	AT 493551 T 15-01-2011
			AU 2004213740 A1 02-09-2004
			BR PI0407674 A 01-03-2006
			CA 2515402 A1 02-09-2004
			EP 1601844 A1 07-12-2005
			IL 169803 A 03-11-2008
			JP 4579231 B2 10-11-2010
			JP 2006518820 A 17-08-2006
			KR 20050103953 A 01-11-2005
			NO 338584 B1 12-09-2016
			NZ 542034 A 27-04-2007
			PL 211011 B1 30-03-2012
			RU 2329363 C2 20-07-2008
			WO 2004074597 A1 02-09-2004
EP 3530840	A1	28-08-2019	DK 3020885 T3 22-07-2019
			EP 3020885 A1 18-05-2016
			EP 3530840 A1 28-08-2019
			ES 2739175 T3 29-01-2020
			PL 3020885 T3 31-12-2019
			US 2016083965 A1 24-03-2016