



- (51) International Patent Classification:
G01N 33/50 (2006.01) *G01N 33/48* (2006.01)
- (21) International Application Number:
PCT/US2012/025270
- (22) International Filing Date:
15 February 2012 (15.02.2012)
- (25) Filing Language: English
- (26) Publication Language: English
- (30) Priority Data:
61/443,088 15 February 2011 (15.02.2011) US
- (71) Applicant (for all designated States except US): **HEMO-SONICS, LLC** [US/US]; 310 4th Street NE, Suite 104, Charlottesville, Virginia 22902 (US).
- (71) Applicant (for US only): **PLATT, Karen** (executrix for the deceased inventor) [CA/CA]; 170 Denison Road, Victoria, British Columbia V8S 4K3 (CA).
- (72) Inventor: **DENNY, Christopher G.** (deceased).

- (72) Inventors; and
- (75) Inventors/Applicants (for US only): **VIOLA, Francesco** [US/US]; 745 Walker Square, #3C, Charlottesville, Virginia 22903 (US). **WALKER, William H.** [US/US]; 778 Belvedere Boulevard, Charlottesville, Virginia 22901 (US). **BROWNE, Gregory V.** [CA/CA]; 617 Pine Street, Victoria, British Columbia V8V 2P6 (CA). **MAGYAR, Robert S.** [CA/CA]; 1826 Belmont Avenue, Victoria, British Columbia V8R 3Z2 (CA). **HANSEN, Bjarne** [CA/CA]; 1000 DeCosta Place, Victoria, British Columbia V9A 6Y3 (CA).
- (74) Agents: **HALL, Miles E.** et al.; McKeon, Meunier, Carlin & Curfman, LLC, Suite 500, 817 W. Peachtree Street NW, Atlanta, Georgia 30308 (US).
- (81) Designated States (unless otherwise indicated, for every kind of national protection available): AE, AG, AL, AM, AO, AT, AU, AZ, BA, BB, BG, BH, BR, BW, BY, BZ, CA, CH, CL, CN, CO, CR, CU, CZ, DE, DK, DM, DO, DZ, EC, EE, EG, ES, FI, GB, GD, GE, GH, GM, GT, HN, HR, HU, ID, IL, IN, IS, JP, KE, KG, KM, KN, KP, KR, KZ, LA, LC, LK, LR, LS, LT, LU, LY, MA, MD, ME, MG, MK, MN, MW, MX, MY, MZ, NA, NG, NI, NO, NZ, OM, PE, PG, PH, PL, PT, QA, RO, RS, RU, RW, SC, SD,

[Continued on next page]

(54) Title: DEVICES, SYSTEMS AND METHODS FOR EVALUATION OF HEMOSTASIS

(57) Abstract: Provided are devices, systems and methods for evaluation of hemostasis. Also provided are sound focusing assemblies.

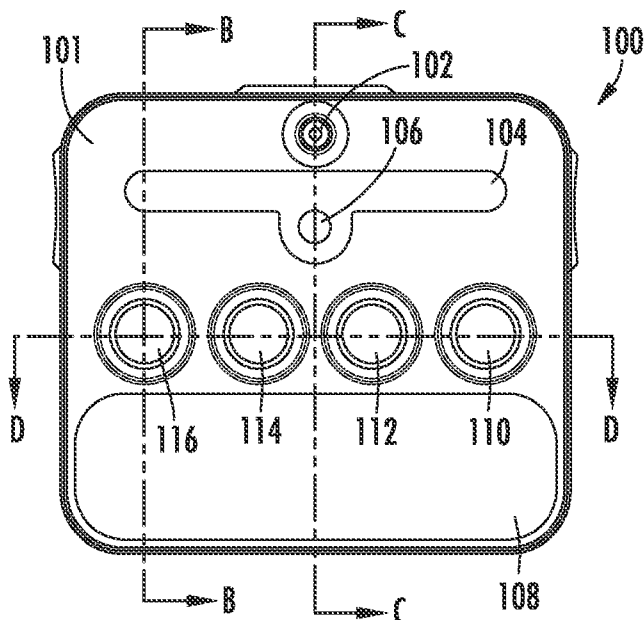

FIG. 1A



SE, SG, SK, SL, SM, ST, SV, SY, TH, TJ, TM, TN, TR, TT, TZ, UA, UG, US, UZ, VC, VN, ZA, ZM, ZW.

(84) Designated States (unless otherwise indicated, for every kind of regional protection available): ARIPO (BW, GH, GM, KE, LR, LS, MW, MZ, NA, RW, SD, SL, SZ, TZ, UG, ZM, ZW), Eurasian (AM, AZ, BY, KG, KZ, MD, RU, TJ, TM), European (AL, AT, BE, BG, CH, CY, CZ, DE, DK, EE, ES, FI, FR, GB, GR, HR, HU, IE, IS, IT, LT, LU, LV, MC, MK, MT, NL, NO, PL, PT, RO, RS, SE, SI, SK, SM, TR), OAPI (BF, BJ, CF, CG, CI, CM, GA, GN, GQ, GW, ML, MR, NE, SN, TD, TG).

Declarations under Rule 4.17:

- as to applicant's entitlement to apply for and be granted a patent (Rule 4.17(ii))
- as to the applicant's entitlement to claim the priority of the earlier application (Rule 4.17(iii))

Published:

- without international search report and to be republished upon receipt of that report (Rule 48.2(g))

DEVICES, SYSTEMS AND METHODS FOR EVALUATION OF HEMOSTASIS**CROSS REFERENCE TO RELATED APPLICATIONS**

This application claims the benefit of U.S. Provisional Application Nos. 61/443,088, filed on February 15, 2011, which is incorporated by reference herein in its entirety.

Technical Field

[0001] The present application relates to devices, systems and methods for evaluating hemostasis in a subject by analysis of a test sample from the subject to determine one or more indices of hemostasis.

BACKGROUND

[0002] Hemostasis, the physiological control of bleeding, is a complex process incorporating the vasculature, platelets, coagulation factors (FI-FXIII), fibrinolytic proteins, and coagulation inhibitors. Disruption of hemostasis plays a central role in the onset of myocardial infarction, stroke, pulmonary embolism, deep vein thrombosis and excessive bleeding. Consequently, *in vitro* diagnostics (IVD) are critically needed to quantify hemostatic dysfunction and direct appropriate treatment. This need is particularly acute during cardiac surgeries requiring cardiopulmonary bypass (CPB), where post-surgical bleeding is a common complication requiring transfusion of blood products.

[0003] Existing IVDs include endpoint biochemical assays, platelet aggregation assays, and clot viscoelastic measurement systems. Endpoint biochemical assays such as the prothrombin time (PT) and the partial thromboplastin time (PTT) are widely used to assess coagulation. However, these tests measure only a part of the hemostatic process and operate under non-physiological conditions incorporating only the function of plasma. As a result of these limitations, complications such as postoperative bleeding often occur despite normal perioperative PT and PTT measurements.

[0004] Activated clotting time (ACT) is an endpoint assay that is most often applied in support of CPB. This assay applies strong initiation of the surface activation (intrinsic) pathway to quantify heparinization. Limitations of the ACT include its disregard for platelet function, lysis, and coagulation kinetics along with the use of large aliquots of whole blood (WB) (generally 2

mL) and moving mechanical parts. For these reasons, the ACT is used for rapid assessment of heparinization and associated protamine reversal with limited utility for additional applications.

[0005] Platelets play a crucial role in the progression of coagulation and quelling arterial bleeding. Furthermore, the modern cell-based theory of hemostasis recognizes that platelets play a modulating role in coagulation. Platelet function is monitored clinically via both central lab assays and point of care (POC) tests, which use anticoagulated WB. Both approaches are limited in that they use platelet aggregation as a proxy for overall platelet function. Furthermore, disabling coagulation, these methods neglect the interaction between platelets and the coagulation cascade.

[0006] Techniques that monitor the viscoelastic properties of WB, such as thromboelastography (TEG) and rotational thromboelastometer (ROTEM), circumvent many of the limitations of endpoint biochemical assays and platelet aggregation assays by measuring the combined effects of all components of hemostasis. TEG has been shown to diagnose hyperfibrinolysis in bleeding patients, indicate transfusion requirements better than standard biochemical assays, and reduce transfusion requirements during CPB when used with transfusion algorithms. While these tests offer valuable clinical information, the devices are typically complex to operate and difficult to interpret. Moreover, the TEG applies relatively large shear strains, which transgress the non-linear viscoelastic regime, thereby disrupting clot formation. For these reasons, the TEG sees very limited utility as a POC test.

SUMMARY

[0007] Provided are devices, systems and methods for evaluation of hemostasis. For example, provided are sonorheometric devices for evaluation of hemostasis in a subject by *in vitro* evaluation of a test sample from the subject. An example device comprises a cartridge having a plurality of test chambers each configured to receive a test sample of blood from the subject. Each test chamber comprises a reagent or combination of reagents.

[0008] A first chamber of the plurality comprises a first reagent or a combination of reagents that interact with the test sample of blood received therein. A second chamber of the plurality comprises a second reagent or combination of reagents that interact with the test sample of blood received therein. The first and second chambers are configured to be interrogated with sound to determine a hemostatic parameter of the test samples.

[0009] The example device can further comprise a third chamber having a third reagent or combination of reagents that interact with the test sample of blood received therein and a fourth

chamber having a fourth reagent or combination of reagents that interact with the test sample of blood received therein. The third and fourth chambers are also configured to be interrogated with sound to determine a hemostatic parameter of the tests samples. Example reagents are selected from the group consisting of kaolin, celite, glass, abciximab, cytochalasin D, thrombin, recombinant tissue factor, reptilase, arachidonic acid (AA), adenosine diphosphate (ADP), and combinations thereof. Optionally, the reagents are lyophilized prior to interacting with the test samples.

[0010] The example devices can be used in a system comprising a transducer for transmitting ultrasound into one or more chamber and for receiving reflected sound from the chamber and the test sample therein. The system can further comprise at least one processor configured to determine a hemostasis parameter from the received sound. The parameters are optionally selected from the group consisting of TC1, TC2, clot stiffness, clot formation rate (CFR), TL1 and TL2. The processor is optionally further configured to determine an intrinsic pathway coagulation factors index, an extrinsic pathway coagulation factors index, a platelets index, a fibrinogen index, and a fibrinolysis index value. The intrinsic and extrinsic coagulation factors are optionally combined to form a coagulation factors index.

[0011] Also provided are sonorheometric methods for evaluation of hemostasis in a subject, comprising a cartridge having at least two test chambers. Each test chamber comprises a reagent or combination thereof. Blood from the subject is introduced into the test chambers to mix with the reagents and ultrasound is transmitted into each test chamber. Sound reflected from the blood reagent mixture in the test chamber is received and processed to generate a hemostasis parameter. The parameters are optionally selected from the group consisting of TC1, TC2, clot stiffness, clot formation rate (CFR), TL1 and TL2. The disclosed methods can further include determining an intrinsic pathway coagulation factors index, an extrinsic pathway coagulation factors index, a platelets index, a fibrinogen index, and a fibrinolysis index value. The intrinsic and extrinsic coagulation factors are optionally combined to form a coagulation factors index. The reagents or combinations thereof are optionally lyophilized prior to mixing with the blood.

[0012] Further provided are sound focusing assemblies. An example sound focusing assembly includes a rigid substrate permeable by sound and an elastomeric couplant permeable by sound. The elastomeric couplant is positioned relative to the rigid substrate to create an interface between the elastomeric couplant and the rigid substrate, wherein the interface focuses sound transmitted through the assembly.

[0013] These and other features and advantages of the present invention will become more readily apparent to those skilled in the art upon consideration of the following detailed description and accompanying drawings, which describe both the preferred and alternative embodiments of the present invention.

BRIEF DESCRIPTION OF THE DRAWINGS

[0014] FIGs. 1A-G are schematic illustrations of an example cartridge for evaluating hemostasis.

[0015] FIG. 2 is a schematic illustration of biological fluid pathways of the example cartridge of FIGs. 1A-G.

[0016] FIG. 3 is a schematic illustration of an example processing system for use with the example cartridge of FIGs. 1A-G.

[0017] FIG. 4 is a schematic illustration of a portion of a system for evaluating hemostasis.

[0018] FIG. 5 is a schematic illustration of a portion of a system for evaluating hemostasis.

[0019] FIG. 6A is a schematic illustration showing N acoustic pulses are sent into a blood sample to generate a force. The resulting deformation can be estimated from the relative time delays between the N returning echoes.

[0020] FIG. 6B is a graph showing example displacement curves generated within a blood sample. As blood clots, reduced displacement is observed.

[0021] FIG. 6C is a graph showing displacements combined to form graphs of relative stiffness, which characterize the hemostatic process. The parameters described in panel are estimated from parameters found by fitting a sigmoidal curve.

[0022] FIG. 7 is a flow diagram illustrating an example method to estimate hemostasis parameters.

[0023] FIGs. 8A-D are schematic illustrations of an example cartridge for evaluating hemostasis.

[0024] FIGs. 9A-C are schematic illustrations of portions of a system for evaluating hemostasis including pressure control mechanisms.

[0025] FIGs. 10A and 10B are schematic illustrations of an example sample flow pattern for use with the described devices and systems and of an example cartridge for evaluating hemostasis.

[0026] FIG. 11 is a graph showing data of heating of blood within an example cartridge for evaluating hemostasis.

[0027] FIGs. 12A-C are schematic illustrations of example sound focusing mechanisms.

DETAILED DESCRIPTION

[0028] The present invention now will be described more fully hereinafter with reference to specific embodiments of the invention. Indeed, the invention can be embodied in many different forms and should not be construed as limited to the embodiments set forth herein; rather, these embodiments are provided so that this disclosure will satisfy applicable legal requirements.

[0029] As used in the specification, and in the appended claims, the singular forms “a,” “an,” “the,” include plural referents unless the context clearly dictates otherwise.

[0030] The term “comprising” and variations thereof as used herein are used synonymously with the term “including” and variations thereof and are open, non-limiting terms.

[0031] As used throughout, by a “subject” is meant an individual. The subject may be a vertebrate, more specifically a mammal (e.g., a human, horse, pig, rabbit, dog, sheep, goat, non-human primate, cow, cat, guinea pig or rodent), a fish, a bird or a reptile or an amphibian. The term does not denote a particular age or sex.

[0032] Figures 1A-G illustrate an example cartridge 100 for use in evaluation of hemostasis in a subject. The cartridge 100 includes a front surface 101 and a rear surface 126. Figure 1A shows a front view of the cartridge 100 and the corresponding front surface 101. The cartridge includes an inlet 102, also referred to herein as an inlet port or entry port, such as a nipple, through which a biological sample from the subject can be introduced into the cartridge. Optionally, a blood sample from the subject is introduced into the cartridge at the inlet 102. Another biological sample that may be introduced for analysis is plasma. The inlet 102 is in fluid communication with a channel 202, which is shown in Figure 2, and which directs the biological sample to other portions of the cartridge as described herein.

[0033] The cartridge further includes a port 106 for applying a vacuum to the cartridge. When a vacuum is applied at the port 106, the biological fluid introduced at the inlet 102 into the channel 202 the fluid is propelled along the channel 202 towards the port 106.

[0034] As shown in Figure 2, in moving between the inlet 102 and the port 106, the biological fluid, or a portion thereof, moves along the channel 202, into the channel 204, the channel 206,

and along the channels 208, 210, 212 and 214. Each of channels 208, 210, 212 and 214 are in fluid communication with a test chamber, also referred to herein, for example, as a, chamber, well or test well or the like. For example, as illustrated in Figure 2, channel 208 is in fluid communication with a test chamber 116, channel 210 is in fluid communication with a test chamber 114, channel 212 is in fluid communication with a test chamber 112, and channel 214 is in fluid communication with a test chamber 110.

[0035] Referring again to Figure 1, each test chamber comprises an open space 124 defined by a portion of the rear surface 126. Figure 1B shows a cross-sectional illustration through test chamber 116 taken across the line B-B of Figure 1A. Figure 1C shows a cross-sectional illustration taken across the line C-C of Figure 1A. Figure 1F shows an expanded view of the circled portion of Figure 1B. Moreover, Figure 1D shows a cross-sectional illustration across the line D-D of Figure 1A, which illustrates the open space of each of the four test chambers.

[0036] Each test chamber is configured to accept a quantity of the biological fluid into the open space. In reference to test chamber 116, illustrated in detail in Figure 1F, a portion of the biological fluid introduced at the inlet 102 moves through the channels 202, 204 and 214 and into the open space 124 of the test chamber 116.

[0037] The biological fluid can also exit each respective test chamber and continue along an exit channel 130 towards the port 106. Thus, fluid introduced at the inlet 102 flows under vacuum through the device channels and into the test chambers. From each test chamber (110, 112, 114, 116), the biological fluid continues to flow along exit channels towards the vacuum.

[0038] Proximate the port 106 each exit channel may direct the flowing biological fluid into a hydrophobic filter at location 222, 220, 218 and 216 respectively. The filters or filter prevents movement of the biological fluid out of the cartridge 100 at the port 106. Because the volume of the channels and the test chamber are fixed, the vacuum can pull the biological fluid into the cartridge until the channels and each test chamber is filled with the biological fluid.

[0039] Pressure can be controlled within the cartridge 100 to, for example, manage flow rate within the consumable 100 and to mitigate reliability issues related to possible user misuse. To measure the properties of a target biological sample, such as a blood sample, a user of the hemostasis system optionally attaches a blood filled syringe to the cartridge 100 unit. There exists the possibility that the user of the hemostasis system 300 (see FIG. 3) could attempt to inject the contents of the applied syringe into the cartridge 100 manually, instead of allowing the device to automatically aspirate the sample. This action may lead to measurement or system

error. A pressure management device in the consumable flow path is used to prevent this user action.

[0040] Inadequate mixing of the biological sample with the reagents described herein may result in variation of hemostasis measurements. Rapidly aspirating the blood sample is optionally used to provide increased mixing of the reagents with the biological sample, such as a blood sample. This is optionally achieved by creating a pressure differential between the cartridge and the aspirating mechanism of the hemostasis system.

[0041] In this regard, Figures 9A-C illustrate three example configurations that can be used to control the pressure differential between the cartridge and the aspirating mechanism and can therefore be used to achieve desired levels of mixing and reduce user errors.

[0042] Figure 9A schematically illustrates an example system 900 for controlling pressure in a cartridge 100. The cartridge includes four test chambers (110, 112, 114 and 116). Each test chamber optionally includes a reagent and operation of the system causes a biological sample to enter one or more test chamber. The example system 900 includes a two way pump 908 which operates to aspirate a biological sample, such as a blood sample. For example, a blood sample can be aspirated into the cartridge from a sample container 902. The pump 908 is in fluid communication with the cartridge 100 and therefore activation of the pump can be used to move the biological sample through the cartridge 100. A pressure transducer 904 is in communication with the pump that measures the gauge pressure drawn by the pump 908. A solenoid actuated valve 906 operates to block flow downstream of the pump allowing gauge pressure to build. The solenoid may be selectively actuated to rapidly expose the pressure gradient to the cartridge. The sample is allowed to progress through the cartridge and is optionally collected in a sample container 910.

[0043] Figure 9B schematically illustrates another example system 920 for controlling pressure in a cartridge 100. The cartridge includes four test chambers (110, 112, 114 and 116). Each test chamber optionally includes a reagent and operation of the system causes a biological sample to enter one or more test chamber. The example system 920 includes a two way pump 908 which operates to aspirate a biological sample, such as a blood sample. For example, a blood sample can be aspirated into the cartridge from a sample container 902. The pump 908 is in fluid communication with the cartridge 100 and therefore activation of the pump can be used to move the biological sample through the cartridge 100. A pressure activated membrane 912 is positioned either upstream or downstream of the cartridge 100 from the pump 908. The

membrane 912 is configured to rupture at a predetermined cartridge gauge pressure thereby controlling the pressure at which the sample is drawn through the cartridge. The sample is allowed to progress through the cartridge and is optionally collected in a sample container 910.

[0044] Figure 9C schematically illustrates another example system 930 for controlling pressure in a cartridge 100. The cartridge includes four test chambers (110, 112, 114 and 116). Each test chamber optionally includes a reagent and operation of the system causes a biological sample to enter one or more test chamber. The example system 930 includes a two way pump 908 which operates to aspirate a biological sample, such as a blood sample. For example, a blood sample can be aspirated into the cartridge from a sample container 902. The pump 908 is in fluid communication with the cartridge 100 and therefore activation of the pump can be used to move the biological sample through the cartridge 100. A closed loop actuated valve 916 contains an internal pressure control mechanism and is used to block flow downstream from the pump allowing gauge pressure to build until a valve pressure setpoint. Once gauge pressure setpoint is reached the valve 916 deploys thereby exposing the cartridge to a desired pressure gradient. The sample is allowed to progress through the cartridge and is optionally collected in a sample container 910.

[0045] The level of sample in each chamber can also be monitored. For example, as shown in Figures 8A-8D, the level of fluid in each chamber can be monitored optically. Figure 8A is a schematic illustration of an example consumable cartridge placed in an example hemostasis evaluation system. Figure 8B is a schematic illustration of a cross section taken across line B-B of Figure 8A. Figure 8C is an expanded schematic illustration of the circled portion of Figure 8B. Figure 8D is a schematic illustration of an example consumable cartridge.

[0046] Whether a desired level has been reached in a given chamber can be indicated by a LED or other visual indicator. Employing a single light beam from an LED emitter 802 reflecting off the chamber at a blood detection target reservoir 224, which is then detected by a detector 800 can be optionally used to optically monitor chamber fluid level.

[0047] For example, blood entering a test chamber reduces reflection of light originating from an emitter 802 located alongside the detector 800, and pointed at the test chamber. A dual beam approach can be used whereby two sources of different wavelengths were reflected off the test chamber. Blood has a deep red color that can be differentiated by comparing the red wavelength reflection to that of another colour.

[0048] The difference in intensity of the reflected red light alone is sufficient to determine when blood has entered a chamber. The red light intensity reflected from the test chamber containing blood was about one-half that of the well containing air, and about two-thirds of that from the well containing water.

[0049] To control the temperature of the biological sample entering the test chambers the cartridge 100 can comprise a heat exchanger in communication with the channel 204. The heat exchanger can be used to maintain, elevate or lower the temperature of the biological fluid before analysis in each test chamber. Optionally, the temperature of biological fluid for analysis in each test chamber is the same such that common portion of the channel system, as shown in Figure 2, is subject to temperature manipulation by the heat exchanger. Optionally, in non-pictured embodiments, the temperature of biological fluid entering each test chamber can be separately controlled.

[0050] For example, to heat the biological fluid, it can be passed through the channel 204 through a polystyrene labyrinth held against a copper block. The copper block can be thin (for example under 2 mm) and sized just larger than the labyrinth to minimize the thermal mass. A thermistor can be embedded in the block so that a control circuit could maintain a steady set temperature in the block. A heater is used that optionally comprises two Watlow® (St. Louis, MO) serpentine foil heating elements bonded to a flexible kapton plastic substrate, and the interface between the block and the heater can be a thin layer of silicone heatsink compound.

[0051] Various flow rates, for example, up to and including 5.99 ml/min or 6.0 ml/min can be used, and power input to the heater can be varied optionally between 8 and 16 Watts. Blood or other biological fluid can be heated in the cartridge from ambient temperature (approximately 20°C) to 37°C at a nominal flow rate of 6 ml/min, which is fast enough to fill the cartridge in 20 seconds. The surface area of the labyrinth used was less than 8 cm².

[0052] Physiologically, the process of coagulation is highly dependent on the temperature at which it takes place. Under normal conditions, coagulation occurs at body temperature (37°C), which is optimal for the proper enzymatic action of the clotting factors in the cascade.

[0053] Blood can be warmed from its incoming temperature, ranging between 18°C and 37°C, to an arbitrary or desired temperature, such as body temperature, of 37°C by passing through a serpentine channel in close proximity to a heater block. To accomplish the heating in a short time over a short path the block can be warmed to almost 60°C when the incoming blood is at the

lower end of its temperature range. The temperature of the blood can also be measured and the heater block can optionally be adjusted to a temperature, ranging from 40°C to 58°C.

[0054] To measure the temperature a sensor can be incorporated in the system 300 (Figure 5) or in the cartridge. Optionally, a thermistor or thermocouple placed in physical contact with the cartridge or blood and an IR thermometer is pointed at the cartridge or blood. In either case the cartridge may incorporate a small well through which the incoming blood passes, rather than having direct contact with the blood. When the cartridge's material (polystyrene) is thin and the blood is kept moving through the well, then the larger heat capacity of the blood ensures the well's wall temperature is close to that of the blood. Optionally, a window allowing the passage of IR is used. The window can comprise a thin layer (e.g. 20um or less) of polyethylene or polystyrene.

[0055] Temperature changes can occur in the body due to fever or in hospital settings such as the emergency room (ER) or operating room (OR). Trauma patients arriving at the ER are treated with large volumes of intravenous saline, which lowers body temperature to as much as 17°C. In the OR, patients undergoing cardiac bypass surgeries (CPB) have their entire blood volume pass through a lung-heart machine, which also lowers blood temperature and can adversely affect coagulation. Also, if there is a lag of time between the time of blood draw and the measurement, the temperature of blood is given time to change.

[0056] Styron® 666 (Styron Inc. Berwyn, PA) polystyrene and the microfluidic heat exchanger channel 204 allows a blood sample to be warmed by a copper block outside of the cartridge that is kept at a constant 37°C. When a sample enters the cartridge at temperatures substantially lower than 37°C, it is optionally desirable to use a cartridge modified to allow for more rapid heating of the biological sample. For example, in a model that simulates the temperature changes over time of blood entering the polystyrene cartridge at 17°C, Styron® 666 was found to reduce ability to heat blood and the blood exiting the heat exchanger did not reach 37°C. These shortcomings of Styron® 666 are due to its relatively low thermal conductivity. When more rapid or efficient heating of the biological sample is desired that is possible through Styron® 666, the cartridge can include materials with higher thermal conductivity than Styron® 666. For example, a thermally conductive polymer (E1201®) from Cool Polymers Inc. (North Kingstown, RI) with improved thermal conductivity properties can be used. This polymer can form a portion of the cartridge between the heating block and the channel 204. By using this polymer in a portion of the cartridge between the heating block and sample, the sample can be more

efficiently heated. For example, FIG. 11 shows that in a cartridge comprising this material blood entering the heat exchanger at 17°C reaches 37°C within 15 seconds.

[0057] Cartridges optionally include both materials, E1201® and Styron® 666, in order to improve the heat transfer to the sample with E1201® on the heated side while maintaining flow visibility on the other side of the consumable with the Styron® 666. Another alternative is to use E1201® as an insert that fits over the copper heater and into a chassis made out of Styron® 666. This is optionally accomplished by overmolding the separate pieces into one single piece or affixing the E1201® to the Styron® chassis by means such as laser, ultrasonic or RF welding. Changing the geometry of the E1201® insert to fit into the larger chassis as a puzzle piece can further improve assembly of the separate parts and help seal the microfluidic flow chambers.

[0058] It may also be desirable to cool the biological fluid in the cartridge. In these example, and similar to when heating is desired, the cartridge can include materials with higher thermal conductivity than Styron® 666. For example, the thermally conductive polymer (E1201®), described above, with improved thermal conductivity properties can be used. This polymer can form a portion of the cartridge between a cooling device, such as a peltier cooling device, and the channel 204. Using this polymer in a portion of the cartridge between the cooling device and sample, the sample can be efficiently cooled.

[0059] Each test chamber can comprise one or more reagents useful in the analysis of one or more indices of hemostasis. Optionally, the reagents are lyophilized. Optionally, one or more lyophilized bead type reagent is used. For example, the lyophilized bead can be a LyoSphere® produced by BioLymph (Minnetonka, MN). A self-contained lyophilized bead is a format that allows for immunochemical and clinical chemistry reagents requiring two or three components that are incompatible as liquids because of their pH level or reaction to one another to coexist compatibly. Because such lyophilized beads are stable and nonreactive, chemicals can be packaged together in the same test chamber.

[0060] To produce lyophilized reagents, a lyophilizer device can be used. For example, the reagent for a given test chamber can be frozen to solidify all of its water molecules. Once frozen, the product is placed in a vacuum and gradually heated without melting the product. This process, called sublimation, transforms the ice directly into water vapor, without first passing through the liquid state. The water vapor given off by the product in the sublimation phase condenses as ice on a collection trap, known as a condenser, within the lyophilizer's vacuum chamber. Optionally, the lyophilized product contains 3% or less of its original

moisture content. The lyophilized product, which may be a pellet, can then be positioned in each test chamber. Once placed in a test chamber, the test chamber can be sealed to prevent unwanted rehydration of the product.

[0061] To locate the lyophilized reagents in the test chambers, the components can first be lyophilized and then the resulting lyophilized product can be placed in the test chambers. Using UV cure epoxy glue or a welding process (such as ultrasound or RF welding), the lens assembly is sealed over each of the test chambers. The assembled cartridge can be sealed in a vapor proof barrier (e.g. a bag) and the vapor barrier can be sealed to preserve the dehydrated nature of the product in the test chambers. When ready for use, the cartridge can be removed from the bag or vapor barrier and placed into an analysis system 300, which is described in further detail below.

[0062] Anti-static treatment of plastic cartridges is optionally used with the lyophilized reagents. Lyophilized reagents are inherently devoid of water, granting them significant electrical insulation.

[0063] Materials that are electrical insulators more readily build up static charge than materials that act as electrical conductors. This can create problems with process control when assembling the cartridges and loading the reagents. Since the cartridges are optionally made from an electrically insulating material (polystyrene, for example), it is not likely to dissipate a static charge build up within the lyophilized reagents. As a result, lyophilized reagents can statically adhere to the interior walls of the consumable. In order to prevent this from occurring, three techniques are optionally implemented to remove static build-up.

[0064] Air ionization is a method that passes directed, ionized air over a target material to neutralize residual static charge on the material surface. Directing ionized air at one or more cartridge test chamber and/or the reagents during the assembly process improves manufacturability by reducing the adherence of the reagent bead to the cartridge test chambers.

[0065] A second method implements cartridge construction using a plastic material that exhibits significantly more conductivity than standard injection molding materials. RTP PermaStat® (Winona, MA) plastics are an example of such materials. The use of this material for the cartridge reduces the adhesion of the lyophilized reagents to the cartridge test chamber walls.

[0066] Third anti-static, liquid sprays are used to temporarily create a dust-free coating on optical lenses and equipment. These sprays reduce static charge on the target surface and are useful for static reduction during the cartridge assembly process.

[0067] When the lyophilized reagents are exposed to the fluid sample, they can generate foam that floats at the surface of the sample in the test chambers. As illustrated in FIGs. 10A and B, the consumable cartridge 1002 optionally comprises a fluidic circuit 202 that delivers the sample from an external vessel, such as a syringe or vacutainer, into one or more test chambers (110, 112, 114, 116) where measurements are performed.

[0068] FIG. 10A shows an example fluidic circuit that can be implemented in a consumable cartridge 1002. This circuit includes an entry port 102, a channel 202, at least one test chamber (110, 112, 114, 116), a filter 1004 and an exit port 1006. The biological sample can be delivered within the chamber by applying a vacuum at the exit port, with the filter allowing air to escape but stopping the fluid. A variety of different reagents can be placed within the test chamber, for example, as described throughout. In order to generate accurate measurements, the reagents are mixed within the sample before testing is initiated. For example, ultrasound emitted into the test chambers can be used to mix the reagents with the sample as described below.

[0069] As shown in FIGs. 10A and 10B, to improve mixing of the foam, a biological fluid sample can flow through the channel 202, which enters the test chamber at the side on a tangent to the chamber. Furthermore, the change in channel diameter from large to small increases the flow velocity (conservation of flow rate) at the entrance to the test chamber. This high flow velocity, in collaboration with gravity, helps generate a re-circulating rotational flow pattern that improves mixing and reagent dispersion with the sample. As the flow enters from the side, it causes any formed foam to be pulled into the flow stream and pushed below the surface.

[0070] FIG. 10B shows a flow pattern implemented in a consumable cartridge designed for injection molding. The fluidic circuit has been repeated four times in order to deliver the sample and mix reagents in four different test chambers. The circuit presented in FIG. 10B also includes a serpentine heat exchanger to adjust the temperature of the incoming sample to a desired level.

[0071] Reagents are mixed with the sample before testing is initiated. Mixing of the reagents can be accomplished using passive and/or active mechanisms. Passive methods include, for example, the use of serpentine channels and embedded barriers to create flow turbulence. Active methods include, for example, magnetic beads, pressure perturbation, and artificial cilia. The consumable cartridge contains a lens that focuses ultrasound energy within the sample that can be used to generate streaming and mixing. The lens, also referred to herein as a lens assembly, or sound focusing assembly, is designed using a soft material, such as a thermoplastic elastomer 134, in conjunction with a rigid substrate 132, such as polystyrene. This combination provides a

dry ultrasound coupling that does not require the use of any fluid or gel couplant. Note that the same lens and ultrasound driver used for hemostasis measurement can be used in this matter to provide mixing. Increasing acoustic energy for mixing can be delivered by, for example, increasing pulse length, pulse amplitude or pulse repetition frequency.

[0072] Mixing can also be provided by a variable magnetic field applied by a series of coils placed outside a test chamber or each test chamber. A small magnetic bead or magnetic stirrer can be placed within a test chamber and when the fluid sample enter the chamber, the current across the coils can be modulated in order to generate a variable magnetic field. This generates motion of the magnetic bead or magnetic stirrer which in turns generates mixing of the sample with the reagent.

[0073] The exposure of blood to surface proteins, such as in the case of collagen or von Willebrand factor (vWF) on damaged blood vessel walls is an essential part of the coagulation process. These proteins not only contribute to the clotting cascade but also modulate several steps leading to clot formation and hemostasis.

[0074] Although exposure to these proteins is essential to the coagulation cascade, standard point-of-care (POC) coagulation assays and devices fail to take this interaction into account. Optionally, the test well(s) and/or channel(s) of a consumable cartridge, such as those described herein, are coated with such surface proteins for the measurement of coagulation within a POC medical device.

[0075] The use of surface protein coatings includes collagen, vWF, fibronectin and any other molecule that modulates coagulation such as fibrinogen and thrombin. A layer of protein on a substrate (glass, polystyrene, polypropylene) creates binding sites that allow the mediation of receptor-ligand interactions between the substrate and other biological materials such as blood in a manner that improves the assessment of coagulation or provides new testing information.

[0076] The interior surfaces of a consumable cartridge can be coated using for example: (1) a layer of such proteins by covalent binding using linker molecules, (2) covalent binding using photochemistries or (3) simple protein adsorption. Linker molecules such as streptavidin or avidin and biotin can be used for this purpose. With linker molecules, the surface of any interior portion of the cartage that will be exposed to the biological sample is biotinylated (coated with a layer of biotin) using commercially available biotin that is conjugated to a reactive group that non-specifically and covalently binds with the substrate. A solution with a high concentration of streptavidin or avidin, which have high affinity for biotin, is added to create a layer of

streptavidin/avidin bound biotin. Addition of biotinylated protein (collagen, vWF, fibronectin, thrombin, fibrinogen) then creates a layer of protein bound to the test well surface that specifically affects coagulation through interactions with plasma proteins and platelets.

[0077] Protein adsorption can be accomplished by filling the wells with a highly concentrated protein solution. Adsorption to the plastic surface takes place almost immediately depending on temperature, pH, surface charges, surface morphology and chemical composition. The solution can then be removed and the surface air dried. Brushing a highly concentrated protein solution on the surface of the wells or dipping the wells into such a solution will accomplish the same purpose.

[0078] The concentration of molecules in the solutions used for coating, whether using linker proteins or adsorption, can be changed to modulate the amount of protein that binds the substrate and, thus, modulate the effects on the coagulation cascade in a way that is relevant to physiology and hemostasis.

[0079] Referring again to Figure 1F, to seal each test chamber, e.g. test chamber 116, a lens assembly 131 includes a rigid substrate 132 and a couplant 134 that can be positioned at the back end of each test chamber. Each couplant 134 comprises an elastomeric material. Optionally, the elastomeric material is a thermoplastic elastomer (TPE). Example elastomeric materials optionally include, Dynaflex D3202, Versaflex OM 9-802CL, Maxelast S4740, RTP 6035. Optionally the couplant is over-molded to the rigid substrate.

[0080] Between each couplant 134 and the open space of each test chamber is a rigid substrate 132. The rigid substrate and the couplant form an interface that focuses ultrasound transmitted (e.g. lens assembly) by an ultrasonic transducer into the chamber's open space and onto any biological fluid and/or reagents in the chamber. The rigid substrate of the lens can comprise a material which allows sound to pass and that can act to focus ultrasound at some level within the space. Optionally, the rigid substrate comprises a styrene, such as, for example Styrene® 666.

[0081] The lens assembly may be glued or welded to the surface 101 to secure the lens in place in an orientation that allows the desired focusing of sound. Alternatively, the lens assembly is optionally manufactured together with the surface 101. In this regard, the rigid substrate 132 can be molded with the surface 101 and the couplant 134 can be overmolded on the rigid substrate. A wide variety of materials can be used to construct the device. For example, plastics can be used for single use, disposable cartridges.

[0082] Each test chamber (116, 114, 112 and 110) can have a lens assembly positioned over the large opening of each chamber's open space. In this way, each chamber can be separately interrogated by focused ultrasound.

[0083] When placed in the analysis system 300, the couplant 134 can be placed in acoustic communication with a transducer for supplying ultrasound through the lens assembly and into a test chamber. Optionally, an intermediate layer of an acoustically permeable material is positioned between an ultrasonic transducer and the couplant. For example, an intermediate layer or block of Rexolite® can be used. The intermediate layer can be forced against the couplant and can be in acoustic contact with the transducer.

[0084] Sound generated by a transducer passes through the intermediate layer, through the couplant, through the rigid substrate, and is focused within the biological sample and reagent in the test chamber. Some of the sound directed into chamber contacts the distal interior surface 111 of the test chamber, which is defined by the surface 126. Optionally, the surface is polystyrene. The distal interior surface has a known geometry and is positioned at a known distance from the ultrasound source. The distal interior surface 111 is used as a calibrated reflector, which is used to estimate the speed of sound and attenuation of sound in a test chamber at base line and during the process of clot formation and clot dissolution. These measurements can be used, for example, to estimate hematocrit of the subject along with the indexes of hemostasis. The sound generated by the transducer can be focused within the biological sample in a test chamber using a parabolic mirror that is coupled to the biological sample using an elastomer.

[0085] Figure 12A illustrates an example geometry for a parabolic mirror that can be used to focus sound into one or more test chamber, wherein $f(x,y)$ is the shape of the focusing reflector, z_0 is the height of the reflector above the active element at the origin, and (x_f, y_f, z_f) is the coordinate of the focal point. The focusing reflector is defined by a curve which is equidistant from the emitting point on the active acoustic element and the focal point. This can be expressed as:

$$d = f(x,y) + \sqrt{(x_f - x)^2 + (y_f - y)^2 + (z_f - f(x,y))^2} \quad (1)$$

Where d is the total distance from the face of the acoustic source to the focus. If the distance is set from the origin to the reflector as z_0 , then the total path-length is:

$$d = z_0 + \sqrt{x_f^2 + y_f^2 + (z_f - z_0)^2} \quad (2)$$

The shape of the reflector can be determined by solving for $f(x,y)$ as follows:

$$d = f(x,y) + \sqrt{(x_f - x)^2 + (y_f - y)^2 + (z_f - f(x,y))^2} \quad (3)$$

$$d - f(x,y) = \sqrt{(x_f - x)^2 + (y_f - y)^2 + (z_f - f(x,y))^2} \quad (4)$$

$$(d - f(x,y))^2 = (x_f - x)^2 + (y_f - y)^2 + (z_f - f(x,y))^2 \quad (5)$$

$$d^2 - 2df(x,y) + f^2(x,y) = (x_f - x)^2 + (y_f - y)^2 + z_f^2 - 2z_f f(x,y) + f^2(x,y) \quad (6)$$

$$d^2 - 2df(x,y) = (x_f - x)^2 + (y_f - y)^2 + z_f^2 - 2z_f f(x,y) \quad (7)$$

$$2z_f f(x,y) - 2df(x,y) = (x_f - x)^2 + (y_f - y)^2 + z_f^2 - d^2 \quad (8)$$

$$f(x,y)(2z_f - 2d) = (x_f - x)^2 + (y_f - y)^2 + z_f^2 - d^2 \quad (9)$$

$$f(x,y) = \frac{(x_f - x)^2 + (y_f - y)^2 + z_f^2 - d^2}{2(z_f - d)} \quad (10)$$

[0086] If z_0 is set, then the equation 2 above can be evaluated and substituted into equation 10 above to yield an equation for the surface of the reflector. The reflector is a parabolic section. Example parameters are optionally an 8mm aperture with a focus at 16 mm laterally, 4mm in range and with an offset between the mirror and aperture of 0.5mm. A diagram of this geometry is shown in Figure 12B. This geometry is useful where the focusing mirror is placed within the system. The mirror can also be placed within the cartridge. In this case, the focus is optionally moved closer in the axial dimension, but further in the lateral dimension as shown in Figure 12C.

[0087] The cartridge 100 can be positioned into pocket 302 of an analysis system 300. As shown in Figure 4, the pocket includes an actuator system 402 for pressing the intermediate layer, such as Rexolite®, that is acoustically coupled to a transducer into contact with the couplant 134. In this way the pocket holds the cartridge in securely in place and in an orientation such that ultrasound can be focused into each testing chamber.

[0088] Figure 5 shows further aspects of the cartridge 100 positioned in the analysis system. The cartridge is positioned such that the intermediate layer 504 is pushed into the couplant 134, which is in communication with the rigid substrate 132 of the lens assembly 131. Ultrasonic generating means 502, including at least one ultrasonic transducer are positioned such that ultrasound is transmitted through the intermediate layer, lens assembly, and into the test chamber.

[0089] At least a portion of the sound is reflected by the biological sample positioned therein the chamber, and a portion of the sound transmitted into the chamber can also be reflected from the chamber distal surface 111. The reflected ultrasound can be received by the ultrasonic transducer and transmitted to the system for processing. Thus the cartridge and the analysis system 300 may be in communication such that data and other operational or processing signals may be communicated between the cartridge and the analysis system.

[0090] A suitable analysis system 300 can therefore comprise one or more processing devices. The processing of the disclosed methods, devices and systems can be performed by software components. Thus, the disclosed systems, devices, and methods, including the analysis system 300, can be described in the general context of computer-executable instructions, such as program modules, being executed by one or more computers or other devices. Generally, program modules comprise computer code, routines, programs, objects, components, data structures, etc. that perform particular tasks or implement particular abstract data types. For example, the program modules can be used to cause the transmission of ultrasound having desired transmit parameters and to receive and process ultrasound to evaluate hemostasis indices of a sample from the subject. The software can also be used to control the heating of the biological sample using the heat exchanger and to monitor and indicate the fill level of a given chamber. The processor can also be used to perform algorithms, to determine hemostatic indices and hematocrit. In some examples, the software can be used to back-out determined hematocrit from determined hemostatic indices. The determined hemostatic indices and hematocrit can be displayed to a medical professional or medical agent for the purpose of making medical decisions for a subject.

[0091] Thus, one skilled in the art will appreciate that the systems, devices, and methods disclosed herein can be implemented via a general-purpose computing device in the form of a computer. The computer, or portions thereof, may be located in the analysis system 300. The components of the computer can comprise, but are not limited to, one or more processors or

processing units, a system memory, and a system bus that couples various system components including the processor to the system memory. In the case of multiple processing units, the system can utilize parallel computing.

[0092] The computer typically comprises a variety of computer readable media. Exemplary readable media can be any available media that is accessible by the computer and comprises, for example and not meant to be limiting, both volatile and non-volatile media, removable and non-removable media. The system memory comprises computer readable media in the form of volatile memory, such as random access memory (RAM), and/or non-volatile memory, such as read only memory (ROM). The system memory typically contains data such as data and/or program modules such as operating system and software that are immediately accessible to and/or are presently operated on by the processing unit.

[0093] In another aspect, the computer can also comprise other removable/non-removable, volatile/non-volatile computer storage media. By way of example, a mass storage device, which can provide non-volatile storage of computer code, computer readable instructions, data structures, program modules, and other data for the computer. For example and not meant to be limiting, a mass storage device can be a hard disk, a removable magnetic disk, a removable optical disk, magnetic cassettes or other magnetic storage devices, flash memory cards, CD-ROM, digital versatile disks (DVD) or other optical storage, random access memories (RAM), read only memories (ROM), electrically erasable programmable read-only memory (EEPROM), and the like.

[0094] Optionally, any number of program modules can be stored on the mass storage device, including by way of example, an operating system and software. Each of the operating system and software, or some combination thereof, can comprise elements of the programming and the software. Data can also be stored on the mass storage device. Data can be stored in any of one or more databases known in the art. Examples of such databases comprise, DB2®, Microsoft® Access, Microsoft® SQL Server, Oracle®, MySQL, PostgreSQL, and the like. The databases can be centralized or distributed across multiple systems.

[0095] In another aspect, the user can enter commands and information into the computer via an input device. Examples of such input devices comprise, but are not limited to, a keyboard, pointing device (*e.g.*, a “mouse”), a touch screen, a scanner, and the like. These and other input devices can be connected to the processing unit via a human machine interface that is coupled to the system bus, but can be connected by other interface and bus structures, such as a parallel

port, game port, an IEEE 1394 Port (also known as a Firewire port), a serial port, or a universal serial bus (USB).

[0096] In yet another aspect, a display device 304, such as a touch screen, can also be connected to the system bus via an interface, such as a display adapter. It is contemplated that the computer can have more than one display adapter and the computer can have more than one display device. For example, a display device can be a monitor, an LCD (Liquid Crystal Display), or a projector.

[0097] Any of the disclosed methods can be performed by computer readable instructions embodied on computer readable media. Computer readable media can be any available media that can be accessed by a computer. By way of example and not meant to be limiting, computer readable media can comprise computer storage media and communications media. Computer storage media comprise volatile and non-volatile, removable and non-removable media implemented in any method or technology for storage of information such as computer readable instructions, data structures, program modules, or other data.

[0098] Example 1

[0099] The reagents in each test chamber, also referred to as a test well, can include all the reagents needed for evaluating one or more indices of hemostasis.

[00100] Optionally the cartridge is a single use, disposable cartridge with pre-loaded lyophilized reagents. The cartridge can be used with whole blood from a subject. The cartridge or assay components include the following for fresh whole blood samples. Four separate wells containing lyophilized reagents to which 1.6 ml of fresh whole blood is added. Each test well utilizes around 300 µl of fresh whole blood along with the following reagents:

[00101] Table 1:

Test Well 1	Test Well 2	Test Well 3	Test Well 4
0.15 mg of kaolin	0.15 mg of kaolin	0.3 U of thrombin	recombinant tissue factor
buffers and stabilizers	buffers and stabilizers	buffers and stabilizers	buffers and stabilizers
0 µl of 2mg/ml abciximab	12 µl of 2mg/ml abciximab	12 µl of 2mg/ml abciximab	0 µl of 2mg/ml abciximab

[00102] The devices systems and methods use the phenomenon of acoustic radiation force to measure changes in mechanical properties (e.g. stiffness) of a blood sample during the processes of coagulation and fibrinolysis. These changes are representative of the role of the four key components of hemostasis: (i) plasma coagulation factors, (ii) platelets, (iii) fibrinogen, and (iv) fibrinolytic factors of the plasma. The basic approach is shown in Figures 6A-C.

[00103] A series of N focused ultrasound pulses are sent into a blood sample at short intervals ΔT (ΔT is on the order of microseconds), as shown schematically in panel A. Each pulse generates a small and localized force within the blood as acoustic energy is absorbed and reflected during propagation. This force, which is concentrated around the focus of the ultrasound beam, induces a small displacement within the blood sample that depends upon the local mechanical properties. These displacements are on the order of 40 microns or less at the focus of the ultrasound beam.

[00104] Each pulse also returns an echo, as a portion of its energy is reflected from within the blood sample. Because the sample moves slightly from one pulse transmission to the next, the path length between the fixed ultrasound emitter and any given region within the target increases with pulse number. This change in path length can be estimated from differences in the arrival times of echoes from the same region. The ensemble of these delays forms a time-displacement curve that holds combined information about viscoelastic properties of the sample. These time-displacement curves are shown in Figure 6B. These time-displacement curves are measured every 6 seconds to fully characterize the dynamics of coagulation and fibrinolysis, representing the entire hemostatic process.

[00105] When the blood sample is in a viscous fluid state, the application of the acoustic force generates large displacements. As coagulation is activated and fibrinogen is cross-linked into fibrin strands, the sample behaves as viscoelastic solid and the induced displacement reduce as the stiffness of the sample increases. The interaction of platelets and the fibrin mesh also further reduce the induced displacements as the clot's stiffness increases. As the clot progresses into the phase of fibrinolysis, the fibrin mesh is dissolved by the fibrinolytic enzymes and the sample returns to viscous fluid, exhibiting increasing displacements.

[00106] The evolution of the magnitude of the induced displacements over time is therefore directly related to the changes in mechanical properties of the blood sample during hemostasis. A curve obtained with this method is shown in Figure 6. Functional data, which

highlights the role of coagulation factors, platelets, fibrinogen, and fibrinolysis can be extracted from the curve, as labeled in the Figure 6.

[00107] Acoustic radiation force results from the transfer of momentum that occurs when a propagating acoustic wave is either absorbed or reflected. This body force acts in the direction of the propagating wave, and can be approximated by the following expression:

$$F = \frac{2\alpha \langle I(t) \rangle}{c} = \frac{2\alpha PII}{c} \frac{1}{\Delta T} \quad (1)$$

[00108] where α [m⁻¹] is the acoustic attenuation coefficient, c [m/s] is the speed of sound, $I(t)$ [W/m²] is the instantaneous intensity of the ultrasound beam, PII is the pulse intensity integral, ΔT [s] is the time interval between successive ultrasound pulse transmissions, and $\langle \rangle$ indicates a time averaged quantity.

[00109] The acoustic energy used by the instrument to generate acoustic radiation force is comparable with the acoustic energy typically used for common medical ultrasound procedures such as color Doppler imaging. The estimated maximum acoustic intensity is on the order of 2.5 W/cm² (time average), which results in a temperature increase of the blood sample of 0.01°C for each measurement ensemble (performed roughly every 6 seconds).

[00110] As the blood sample rapidly changes from viscous fluid to viscoelastic solid during coagulation and back to viscous fluid after clot lysis, the applied acoustic radiation force is adaptively changed to induce displacements above the noise threshold, but below levels that could induce mechanical disruption (typically below 40 microns).

[00111] The magnitude of the force is adjusted to follow the changes in mechanical properties of the blood sample by varying the time interval ΔT between successive pulses, as shown in equation 1. The maximum displacement induced during the (m-1)th acquisition is used to determine whether the force should be increased or decreased for the mth acquisition, based on predetermined threshold values. This adaptive process allows characterization of five orders of magnitude in stiffness without generating high strain within the blood sample that could alter the dynamics of coagulation and fibrinolysis.

[00112] As shown in equation (1), the applied acoustic radiation force changes as a function of acoustic attenuation and speed of sound, both of which change as a function of coagulation. The system uses the echoes returning from within the cartridge to estimate changes in these parameters and normalize the acoustic radiation force.

[00113] Acoustic radiation force is generated using conventional piezoelectric materials that act as acoustic emitters and receivers. These materials deform when a voltage is applied across them, and conversely generate a voltage when they are deformed. Similar to optics, an acoustic lens can be placed in front of the piezoelectric material to focus acoustic energy on a single focal point.

[00114] In the example systems, method, and devices piezoelectric disks are used that have an active diameter of 7.5 mm. The acoustic lens is provided by the curved shape of the disposable cartridge. Four disks are placed side by side to send sound in the four test wells in a disposable. The frequency of vibration of these piezoelectric disks is centered at 10 MHz, well within the range of frequencies used in conventional ultrasound imaging.

[00115] Ultrasound echo signals returning to the transducers from the blood samples are first filtered to remove electronic noise, digitized, and further processed within an embedded processor in the system. A flow chart of the data analysis steps performed by the system is shown in Figure 7 where a test starts at block 700. Ultrasound pulses are transmitted into a target sample in a test well at 702. Echoes are received, filtered and digitized at 704. After a short wait 706, steps 702 to 704 can be repeated. A time delay estimation is applied at 708 and an curve fitting at 710. The system then determines if enough data has been acquired to estimated the desired indexes of hemostasis at 712. If there is enough data to estimate a hemostasis index, the hemostasis index is estimated and 714 and displayed at 716. If at 712 it is determined that not enough data has been acquired to estimated a hemostasis index, the system determines if the test should be stopped at 718 and, if so, an output summary is generated at 722. If the test is to continue, after a long wait 770, one or more steps 702-770 are optionally repeated.

[00116] Time delay estimation

[00117] Once an ensemble of N pulses is sent into the blood sample and the returning echoes are obtained, time delay estimation (TDE) is performed to estimate a local time-displacement curve, similar to that shown in Figure 6B. TDE entails measuring the relative time shift from one received echo to the next; the known value of the speed of sound in blood allows conversion of the time shifts into displacements. TDE is performed around the focus of the ultrasound beam. This process is repeated every 6 seconds (arbitrary fixed wait) to obtain time-displacement curves throughout the process of coagulation and fibrinolysis.

[00118] A variety of “off-the-shelf” algorithms are available to perform this operation. TDE is a common signal processing step in application fields ranging from RADAR, SONAR, and medical ultrasound imaging (Doppler).

[00119] Curve fitting

[00120] The viscoelastic properties of the blood sample during hemostasis are modeled using a modified model consisting of the well-known Voigt-Kelvin mechanical model with the addition of inertia. While the dynamic changes in viscoelasticity of blood during hemostasis are certainly complex, the modified Voigt-Kelvin model is simple and robust, and it has been well validated in the past.

[00121] Each time-displacement curve is fitted to the characteristic equation of the modified Voigt-Kelvin model to estimate a variety of parameters relating to the viscoelastic properties of the sample. These parameters include relative elasticity, relative viscosity, time constant, and maximum displacement. The mathematical expression of the equation of motion for the modified Voigt-Kelvin model is

$$x(t) = -\frac{\xi + \sqrt{\xi^2 - 1}}{2\sqrt{\xi^2 - 1}} s \cdot e^{(-\xi + \sqrt{\xi^2 - 1})\omega t} + \frac{\xi - \sqrt{\xi^2 - 1}}{2\sqrt{\xi^2 - 1}} s \cdot e^{(-\xi - \sqrt{\xi^2 - 1})\omega t} + s \quad (2)$$

[00122] where ξ is the damping ratio, ω is the natural frequency, and s is the static sensitivity.

[00123] Among the parameters obtained by the curve fitting, the system uses the estimated displacement magnitude at 1 second as a qualitative measure of the stiffness of the sample. When blood is in viscous fluid state, the displacement at 1 second is high. As the blood coagulates this displacement decreases proportionally to the generation of the fibrin mesh and activity of platelets. The value increases again during the process of fibrinolysis.

[00124] Estimate indices of hemostatic function

[00125] The displacement values obtained at 1 second for each data acquisition are compiled to form a curve showing relative stiffness as a function of time (Figure 6C). This curve, previously shown, fully characterizes hemostasis and can be further processed to estimate direct indices of hemostatic function.

[00126] Indices of hemostasis are calculated by fitting a sigmoidal curve to the stiffness-time curve (Figure 6C) and evaluating the first derivative of the curve. The times to clot TC1 and TC2 are calculated based on a threshold value of the derivative curve (20% of the minimum value), and are indicative of the beginning and ending phase of fibrin polymerization. The clotting slope CFR is the maximum of the derivative curve and is indicative of the rate of fibrin polymerization. The stiffness S is estimated from the stiffness curve 3 minutes after TC2. S depends upon platelet function and the final stiffness of the fibrin network. Identical methods and indices are calculated for the fibrinolytic process. In particular the times TL1 and TL2 can be defined to represent the initial and final phases of the fibrinolytic process and the consequent dissolution of the fibrin network (time to lysis).

[00127] A summary of the parameters generated for each test chamber is presented in the table 2:

Parameter	Information provided	Dependent upon
TC ₁ , TC ₂	Measure initial and final fibrin formation	Function of fibrinogen and other coagulation factors
S	Fibrin and platelet activity	Function of fibrin network and platelet aggregation
CFR	Rate of fibrin polymerization	Function of fibrinogen and other coagulation factors
TL ₁ , TL ₂	Clot dissolving process	Function of fibrinolytic proteins of the plasma

[00128] In order to isolate the four main components of hemostasis, four measurements are performed in parallel within the disposable cartridge using a combination of agonists and antagonists in each of four wells. The measurements in each well are combined to form indices of hemostasis as shown in the table 3:

Output	Method
Coagulation factors Index (Intrinsic Pathway)	Time to clot TC ₁ in well #1
Coagulation factors Index (Extrinsic Pathway)	Time to clot TC ₁ in well #4
Platelets Index	Stiffness S differential between well #1 and well #2
Fibrinogen Index	Stiffness S in well #3

Output	Method
Fibrinolysis Index	Time to lysis TL ₁ in well #4

[00129] Many modifications and other embodiments of the invention set forth herein will come to mind to one skilled in the art to which this invention pertains having the benefit of the teachings presented in the foregoing description. Therefore, it is to be understood that the invention is not to be limited to the specific embodiments disclosed and that modifications and other embodiments are intended to be included within the scope of the appended claims. Although specific terms are employed herein, they are used in a generic and descriptive sense only and not for purposes of limitation.

CLAIMS

What is claimed is:

1. A device for evaluation of hemostasis, comprising:
 - a. a plurality of test chambers each configured to receive a test sample of blood, each test chamber comprising a reagent or combination of reagents;
 - b. wherein a first chamber of the plurality comprises a first reagent or a combination of reagents that interact with the test sample of blood received therein;
 - c. wherein a second chamber of the plurality comprises a second reagent or combination of reagents that interact with the test sample of blood received therein; and
 - d. wherein the first and second chambers are configured to be interrogated to determine a hemostatic parameter of the test samples.
2. The device of claim 1, further comprising:
 - a. a third chamber comprising a third reagent or combination of reagents that interact with the test sample of blood received therein;
 - b. a fourth chamber comprising a fourth reagent or combination of reagents that interact with the test sample of blood received therein; and
 - c. wherein the third and fourth chambers are configured to be interrogated to determine a hemostatic parameter of the test samples.
3. The device of claim 1 or 2, wherein the interrogation comprises measurement of at least one viscoelastic property of the test sample.
4. The device of claims 1, 2 or 3, wherein the interrogation comprises use of acoustic radiation force.
5. The device of claim 1-4, wherein the interrogation comprises transmission of sound into one or more test chamber.

6. The device of claims 1-5, wherein the reagents are selected from the group consisting of kaolin, celite, glass, abciximab, cytochalasin D, thrombin, recombinant tissue factor, ADP, arachidonic acid, reptilase, and combinations thereof.
7. The device of claim 6, wherein the reagents are lyophilized prior to interacting with the test samples.
8. The device of claims 1-7, wherein each test chamber is at least partially defined by a housing.
9. The device of claim 8, wherein the device is configured for use with a single test sample.
10. The device of claims 1-9, further comprising a fluid pathway having an inlet for receiving a test sample, wherein the fluid pathway is in communication with at least one test chamber to deliver the test sample, or a portion thereof, to one or more of the test chambers.
11. The device of claim 10, wherein the device comprises a housing that defines at least a portion of at least one test chamber and of the fluid pathway, and wherein at least a portion of the housing is thermally conductive.
12. The device of claim 11, wherein in the thermally conductive portion of the housing defines at least a portion of the fluid pathway.
13. The device of claim 12, wherein the thermally conductive portion comprises a thermally conductive polymer.
14. The device of claim 13, wherein the thermally conductive polymer is E1201.
15. The device of claims 10-14, wherein the fluid pathway further comprises a channel in communication with at least one test chamber, and wherein sample delivered from the channel into the test chamber results in mixing of at least a portion of the sample and the reagent within the test chamber.
16. The device of claims 10-15, wherein the fluid pathway further comprises a channel that opens into at least one test chamber on the side and at a tangent to the test chamber.
17. The device of claims 1-16, wherein one or more test chamber further comprises a magnetic stirring structure.

18. The device of claims 1-17, wherein a portion of at least one test chamber, or the fluid pathway, that are in contact with the test sample are coated with one or more surface proteins.
19. The device of claim 18, wherein the surface proteins are selected from the group consisting of collagen, von Willebrand factor (vWF), fibronectin, fibrinogen, and thrombin.
20. A system comprising the device of claims 1-19, and further comprising:
 - a. a transducer for transmitting ultrasound into one or more test chamber and for receiving reflected sound from the chamber and the test sample therein; and
 - b. at least one processor configured to determine a hemostasis parameter from the received sound.
21. The system of claim 20, wherein the hemostasis parameter is selected from the group consisting of TC1, TC2, clot stiffness, clot formation rate (CFR), TL1, TL2, baseline viscosity and post lysis viscosity.
22. The system of claim 20, wherein the processor is further configured to determine a coagulation factors index.
23. The system of claim 22, wherein the coagulation factors index is an intrinsic pathway coagulation factors index.
24. The system of claim 22, wherein the coagulation factors index is an extrinsic pathway coagulation factors index.
25. The system of claim 20, wherein the processor is further configured to determine an intrinsic pathway coagulation factors index, an extrinsic pathway coagulation factors index, a platelets index, a fibrinogen index, and a fibrinolysis index.
26. The system of claims 20-25, further comprising a pump in communication with the fluid pathway.
27. The system of claim 26, further comprising a pressure transducer in communication with the pump to measure gauge pressure of the pump when the pump is activated.
28. The system of claim 27, further comprising a valve operable to block flow from the pump to allow the gauge pressure of the pump to build when the pump is activated.

29. The system of claim 28, wherein the valve is openable to expose the gauge pressure to the fluid pathway.
30. The system of claim 26, further comprising a pressure activated membrane in communication with the fluid pathway and pump, wherein the membrane is configured to rupture at a predetermined gauge pressure produced by the pump when the pump is activated.
31. The system of claim 26, further comprising a valve configured to open at a predetermined gauge pressure produced by the pump when the pump is activated.
32. The system of claim 26, further comprising a magnetic field generator configured to apply a magnetic field to the magnetic stirring structure.
33. The system of claims 20-32, further comprising one or more sound focusing apparatus positioned to focus sound into one or more test chamber.
34. The system of claim 38, wherein the sound focusing apparatus is a lens.
35. The system of claim 38, wherein the sound focusing apparatus is a sound reflector.
36. A method for evaluation of hemostasis in a subject, comprising:
- a. providing at least two test chambers, each test chamber including a reagent or combination thereof;
 - b. introducing blood from the subject into the test chambers to mix with the reagent or reagents;
 - c. interrogating the mixed blood and reagent in the test chamber to determine a hemostatic parameter of the test samples.
37. The method of claim 36, wherein the interrogation comprises measurement of at least one viscoelastic property of the test sample.
38. The method of claim 36, wherein the interrogation comprises transmitting sound into one or more test chamber to produce acoustic radiation force.
39. The method of claims 36-38, wherein the parameters are selected from the group consisting of TC1, TC2, clot stiffness, clot formation rate (CFR), TL1 and TL2.
40. The system of claim 36-38, wherein the processor is further configured to determine a coagulation factors index.

41. The system of claim 40, wherein the coagulation factors index is an intrinsic pathway coagulation factors index.

42. The system of claim 40, wherein the coagulation factors index is an extrinsic pathway coagulation factors index.

43. The method of claims 36, further comprising determining an intrinsic pathway coagulation factors index, an extrinsic pathway coagulation factors index, a platelets index, a fibrinogen index, and a fibrinolysis index.

44. The method of claims 36-43, wherein the reagents or combinations thereof are lyophilized prior to mixing with the blood.

45. A sonorheometric method for evaluation of hemostasis in a subject, comprising:

- a. providing at least two test chambers, each test chamber including a reagent or combination thereof;
- b. introducing blood from the subject into the test chambers to mix with the reagents;
- c. transmitting ultrasound into each test chamber;
- d. receiving sound reflected from the blood reagent mixture in the test chamber; and
- e. processing the received sound to generate a hemostasis parameter.

46. The method of claim 45, wherein the parameters are selected from the group consisting of TC1, TC2, clot stiffness, clot formation rate (CFR), TL1 and TL2.

47. The system of claim 46, wherein the processor is further configured to determine a coagulation factors index.

48. The system of claim 47, wherein the coagulation factors index is an intrinsic pathway coagulation factors index.

49. The system of claim 47, wherein the coagulation factors index is an extrinsic pathway coagulation factors index.

50. The method of claim 46, further comprising determining an intrinsic pathway coagulation factors index, an extrinsic pathway coagulation factors index, a platelets index, a fibrinogen index, and a fibrinolysis index.

51. The method of claim 45-50, wherein the reagents or combinations thereof are lyophilized prior to mixing with the blood.
52. An sound focusing assembly, comprising:
- a. a rigid substrate permeable by sound; and
 - b. an elastomeric couplant permeable by sound and positioned relative to the rigid substrate to create an interface between the elastomeric couplant and the rigid substrate.
53. The sound focusing assembly of claim 52, wherein said interface focuses sound transmitted through said assembly.
54. The sound focusing assembly of claim 52, wherein the rigid substrate is in communication with a test material to form an interface, and wherein said interface focuses sound transmitted through said assembly.
55. The sound focusing assembly of claim 54, wherein the interface between the elastomeric couplant and the rigid substrate is substantially flat.
56. The sound focusing assembly of claims 54-55, wherein the interface between the rigid substrate and the test material is not flat.
57. The sound focusing assembly of claims 54-56, wherein the test material comprises blood or plasma.
58. The sound focusing assembly of claim 52-57, wherein the rigid substrate comprises a styrene or Rexolite® 1422.
59. The sound focusing assembly of claims 52-58, wherein the elastomeric couplant comprises a thermoplastic elastomer (TPE).
60. The sound focusing assembly of claims 52-59, wherein the elastomeric material is selected from the group consisting of Dynaflex D3202, Versaflex OM 9-802CL, Maxelast S4740, and RTP 6035.
61. The sound focusing assembly of claims 52-60, further comprising a sound generator positioned relative to the couplant and rigid substrate to generate and transmit sound first through the couplant and then through the rigid substrate.
62. The sound focusing assembly of claim 61, wherein the sound generator is an ultrasonic transducer.

63. The sound focusing assembly of claim 62, wherein the ultrasonic transducer is positioned relative to the couplant and rigid substrate to transmit sound first through the couplant and then through the rigid substrate.

64. The sound focusing assembly of claims 52-63, wherein the sound has a frequency of at least 1 megahertz.

65. The sound focusing assembly of claim 64, wherein the sound has a frequency of 10 megahertz or higher.

66. The sound focusing assembly of claims 52-65, further comprising a sound permeable intermediate layer positioned between the sound generator and the couplant.

67. The sound focusing assembly of claim 66, wherein the intermediate layer is coupled directly to the couplant.

68. The sound focusing assembly of claim 67, wherein the sound generated and transmitted by the sound generator is transmitted through the intermediate layer, then through the couplant and then through the rigid substrate.

69. The sound focusing assembly of claims 61-68, wherein the sound generator is further configured to receive sound.

70. The sound focusing assembly of claim 69, wherein the sound generator is further configured to receive sound that passes first through the couplant and then through the rigid substrate.

71. A system for focusing sound into a substance, comprising:

- a. the sound focusing assembly of claim 66; and further comprising
- b. an actuator in communication with the intermediate layer, wherein activation of the actuator forceably pushes the intermediate layer against the couplant.

72. The system of claim 71 wherein the substance is a biological tissue.

73. The system of claim 72, wherein the substance is blood or plasma.

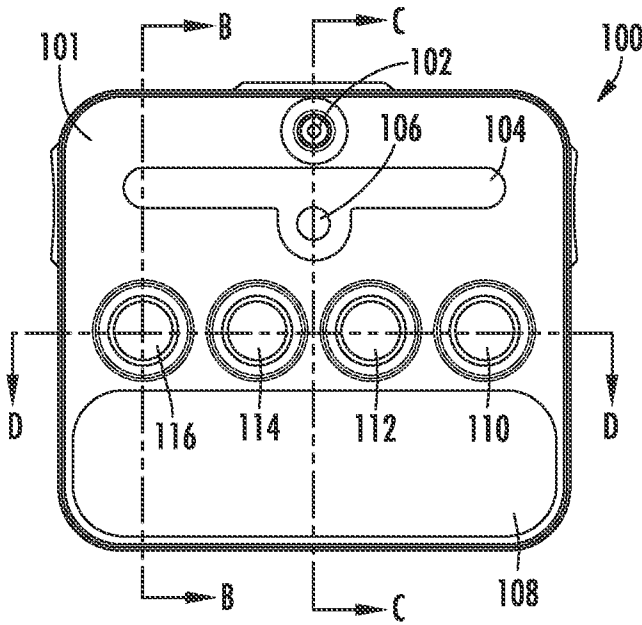

FIG. 1A

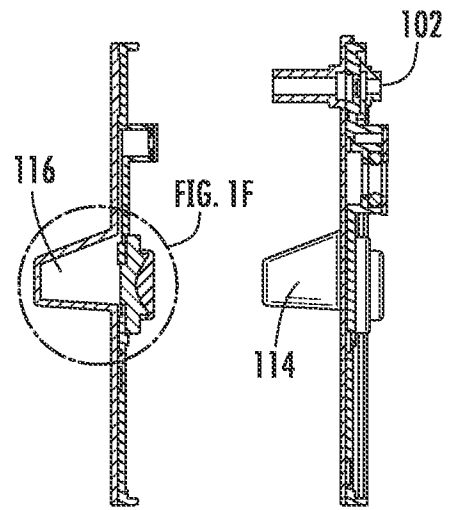

FIG. 1B

FIG. 1C

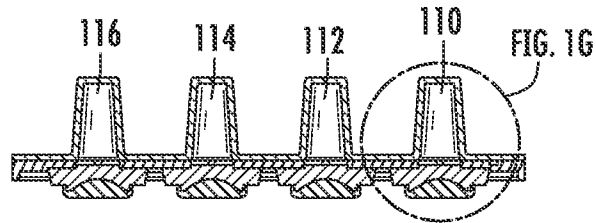

FIG. 1D

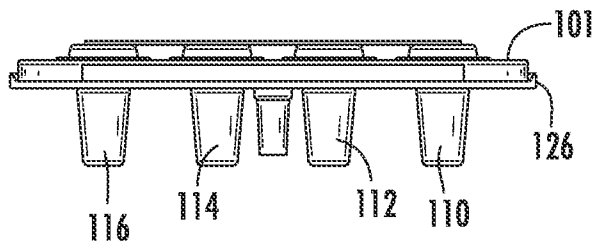

FIG. 1E

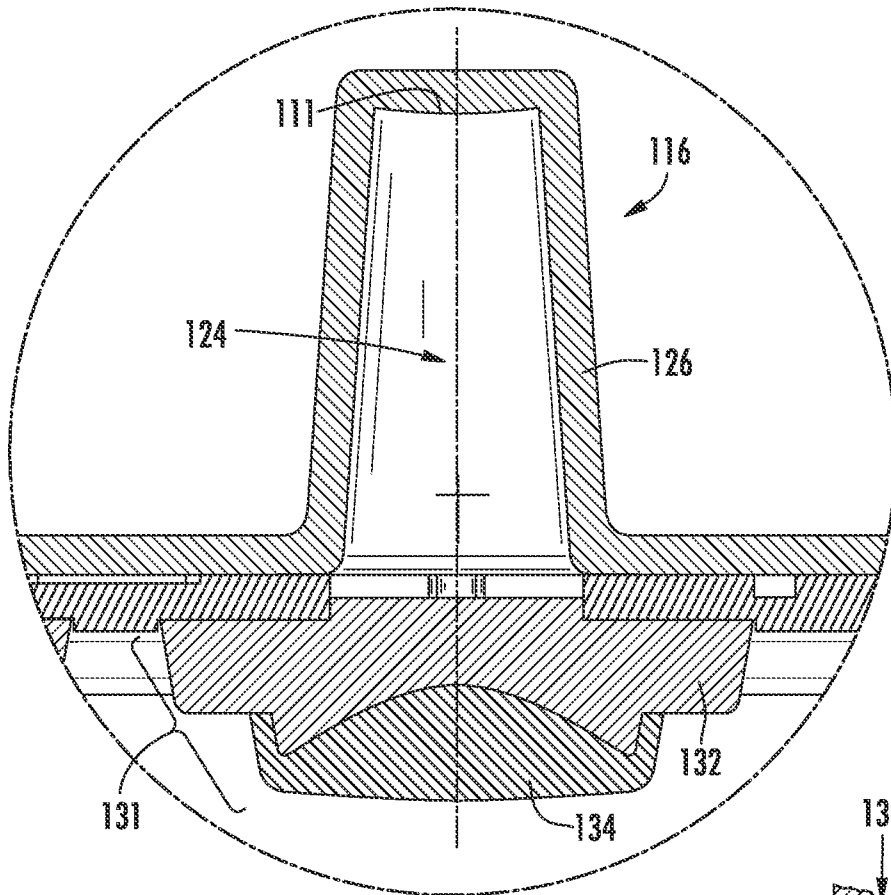

FIG. 1F

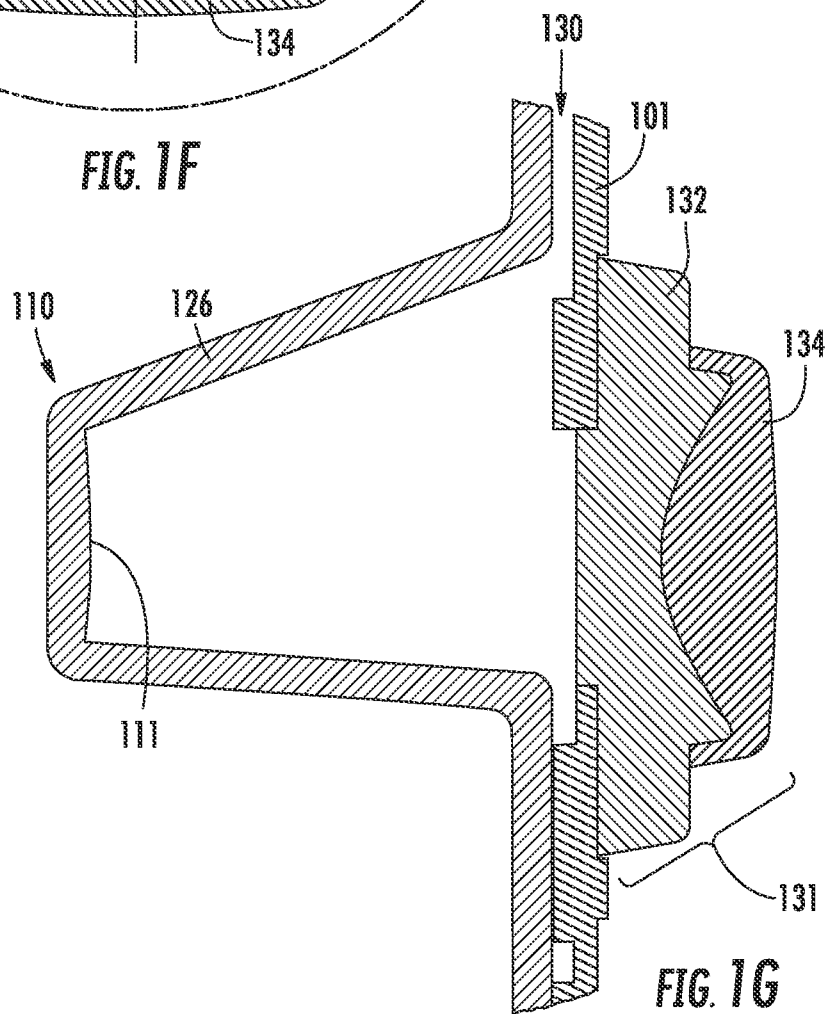

FIG. 1G

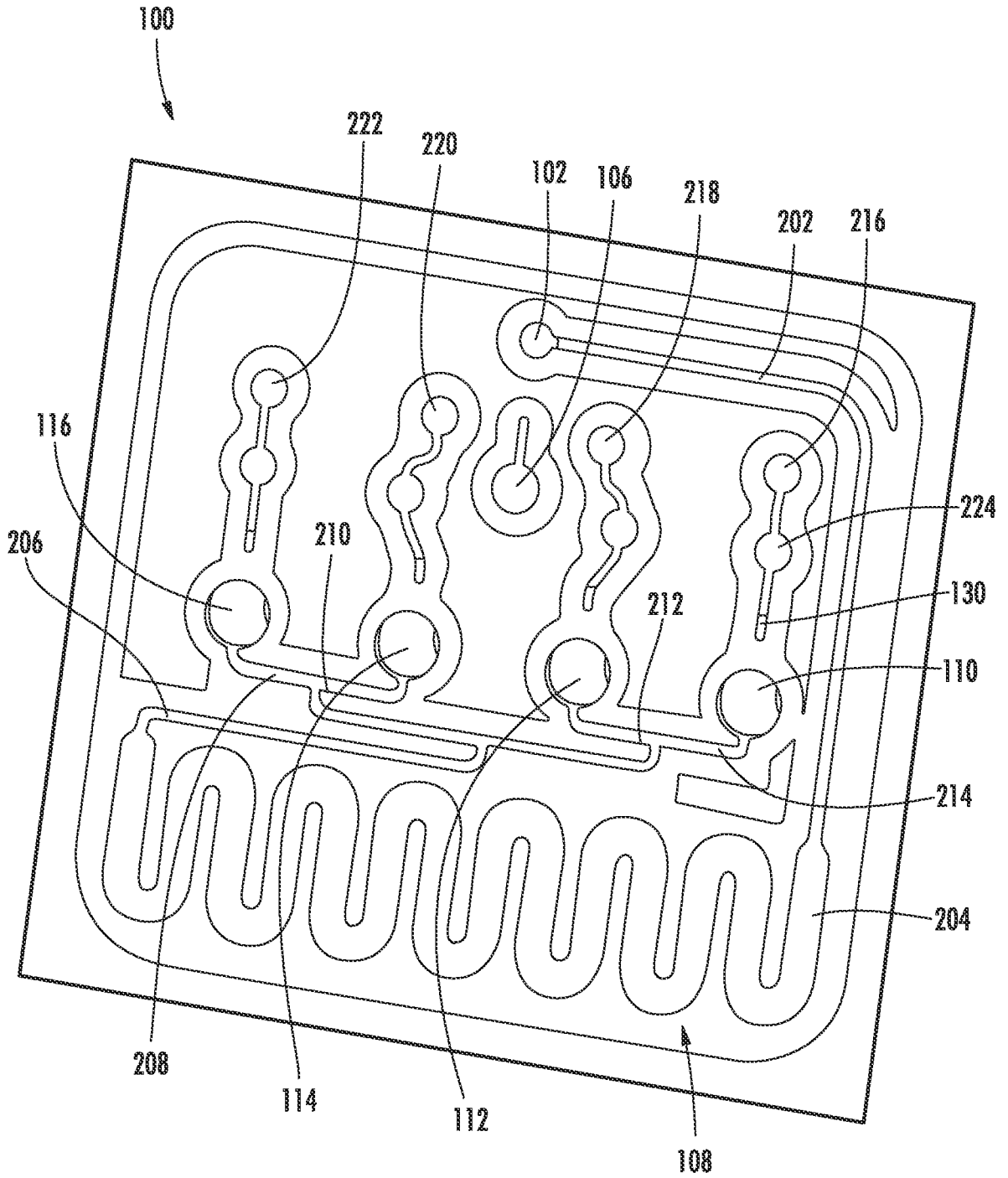

FIG. 2

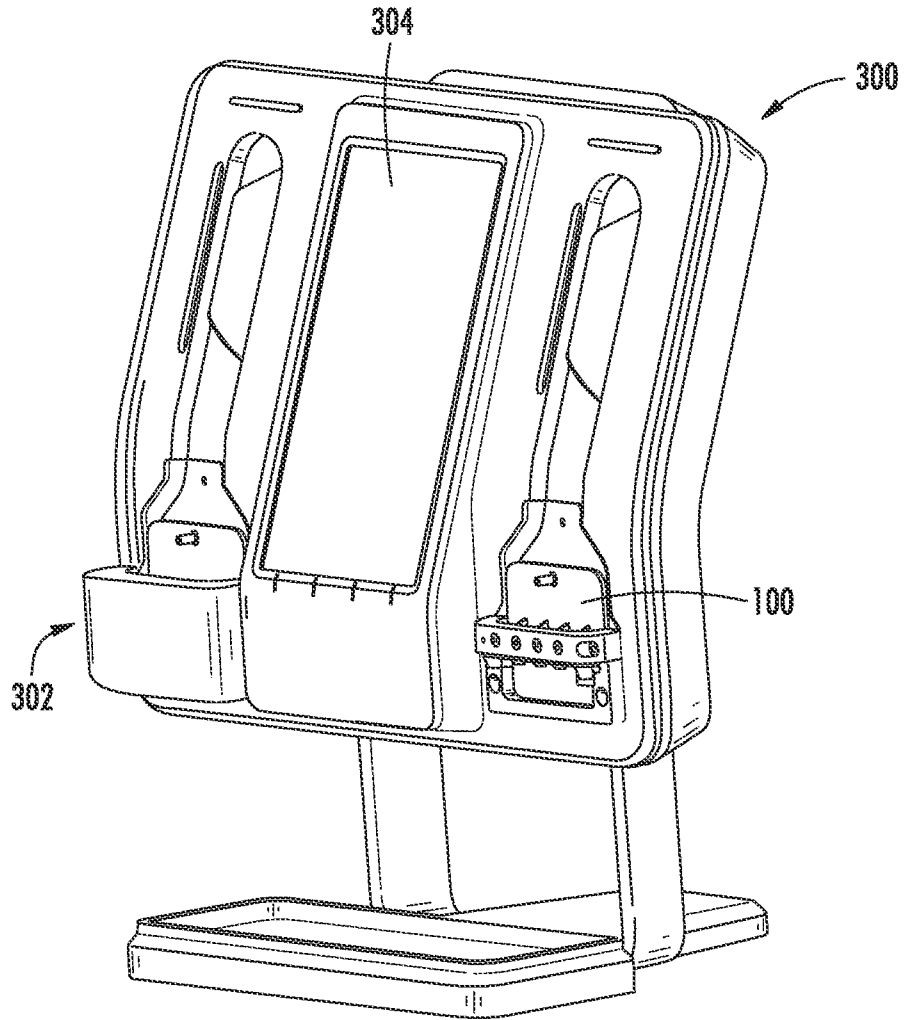

FIG. 3

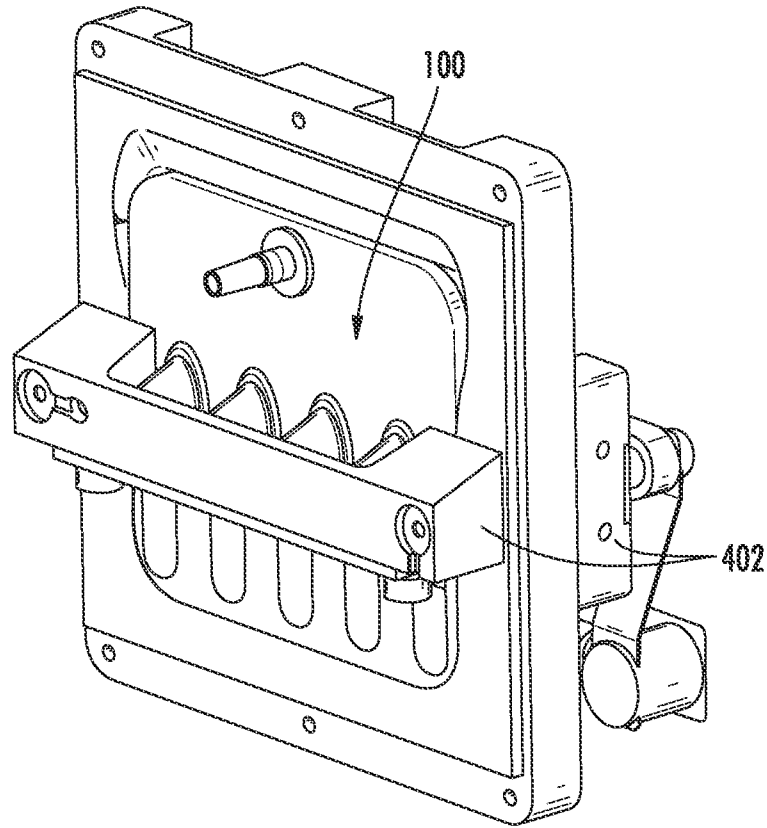

FIG. 4

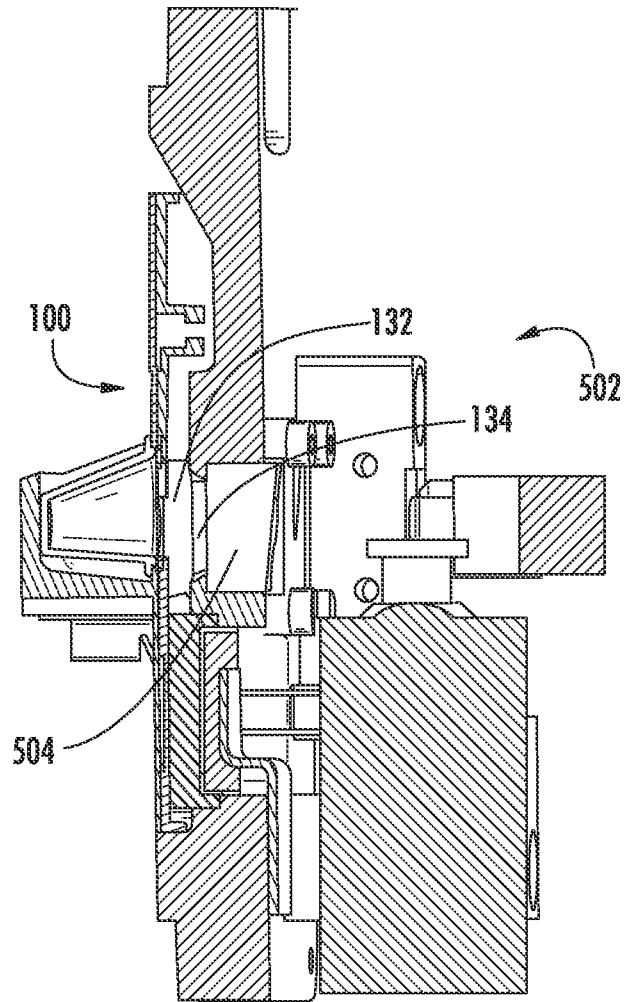

FIG. 5

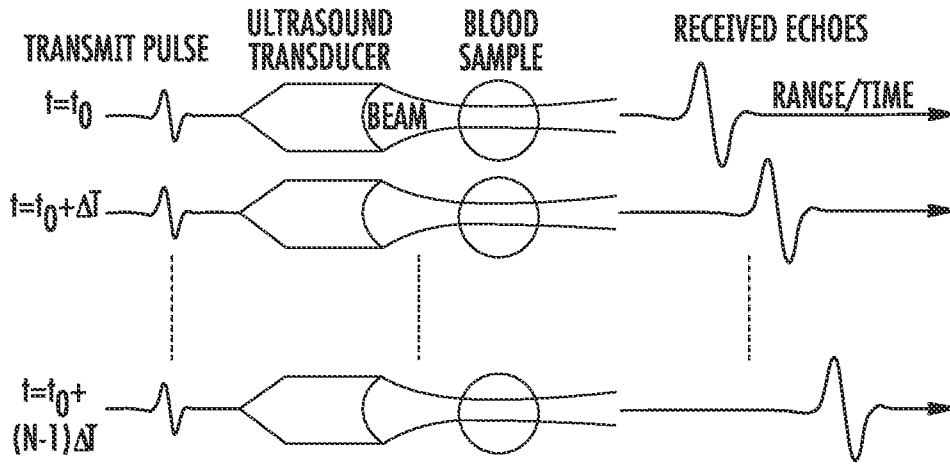

FIG. 6A

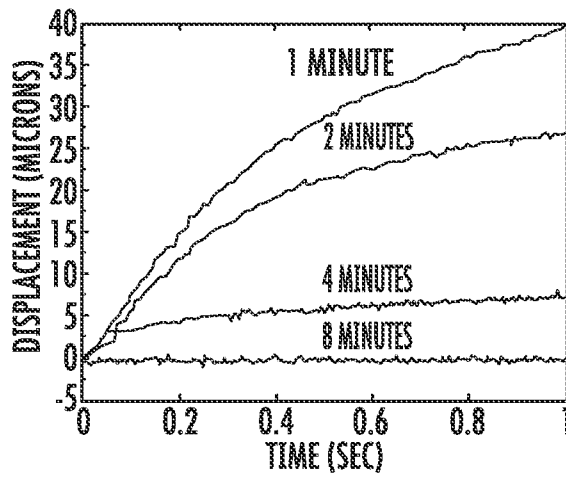

FIG. 6B

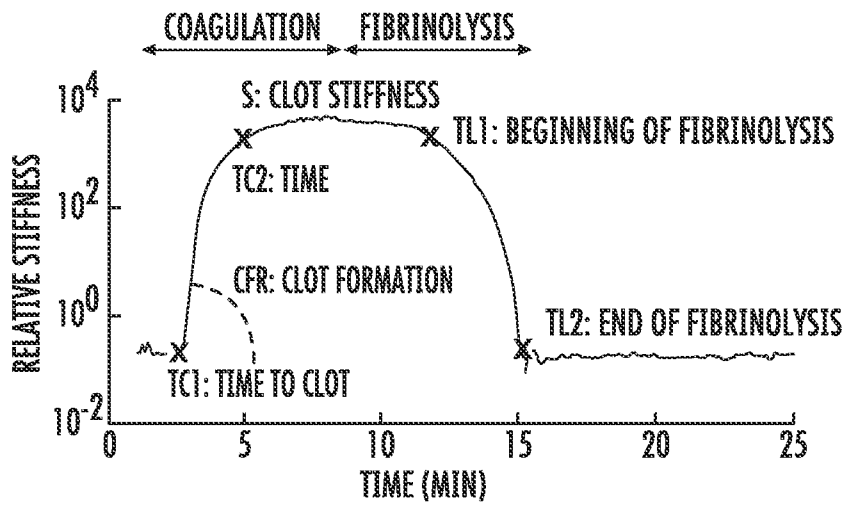

FIG. 6C

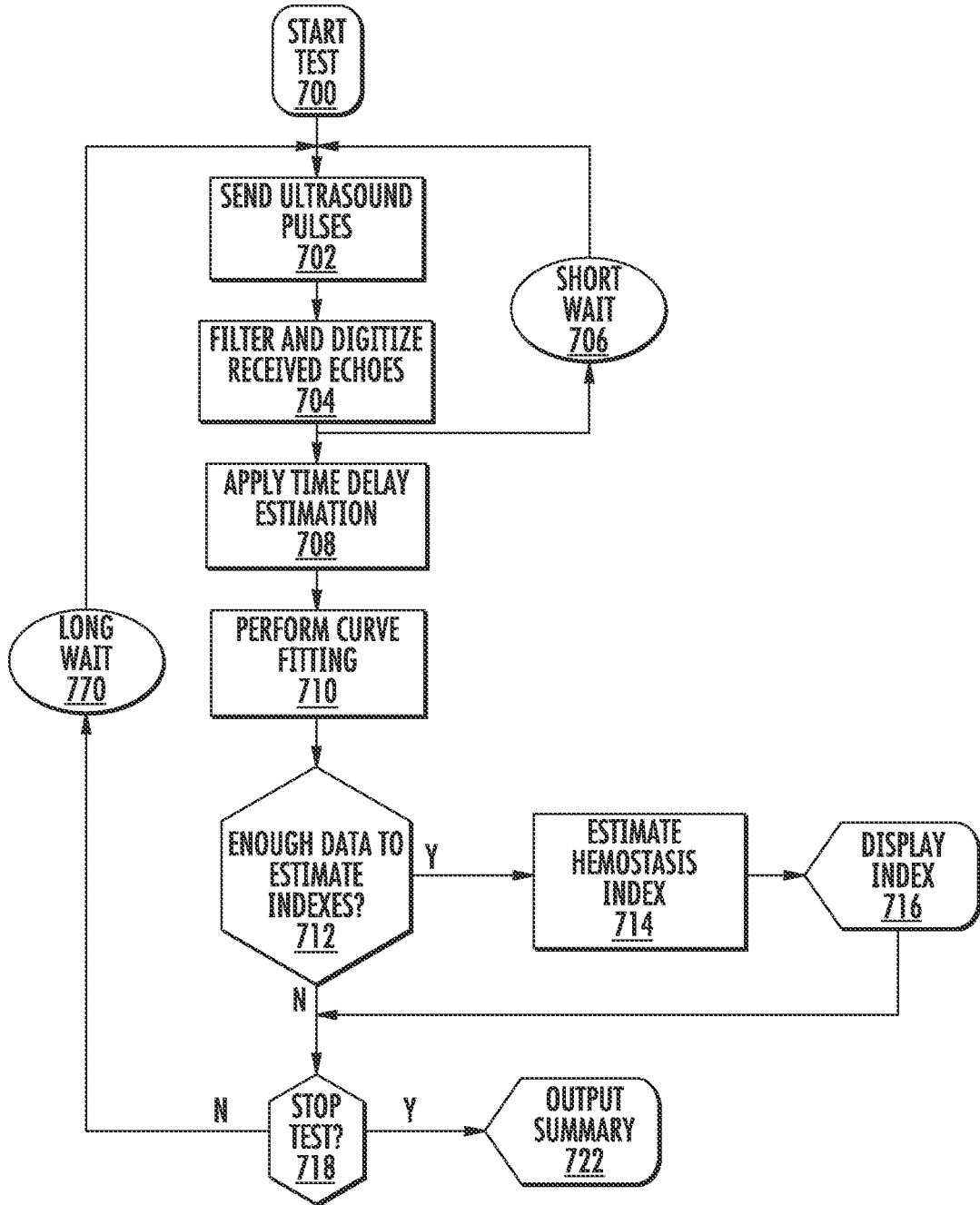

FIG. 7

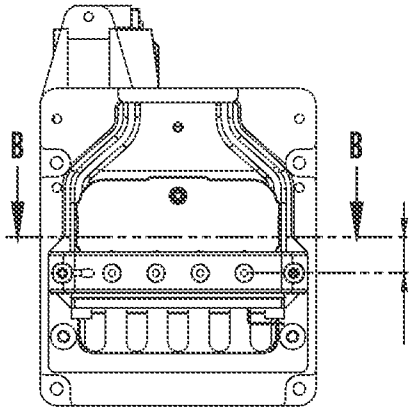

FIG. 8A

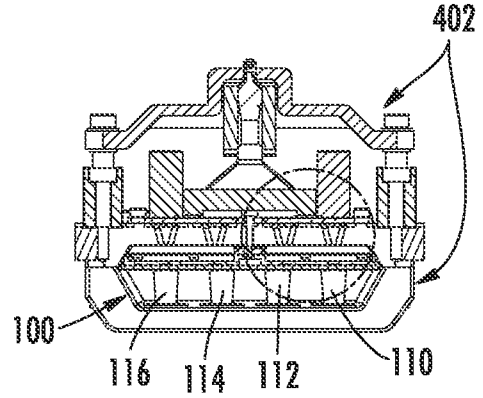

FIG. 8B

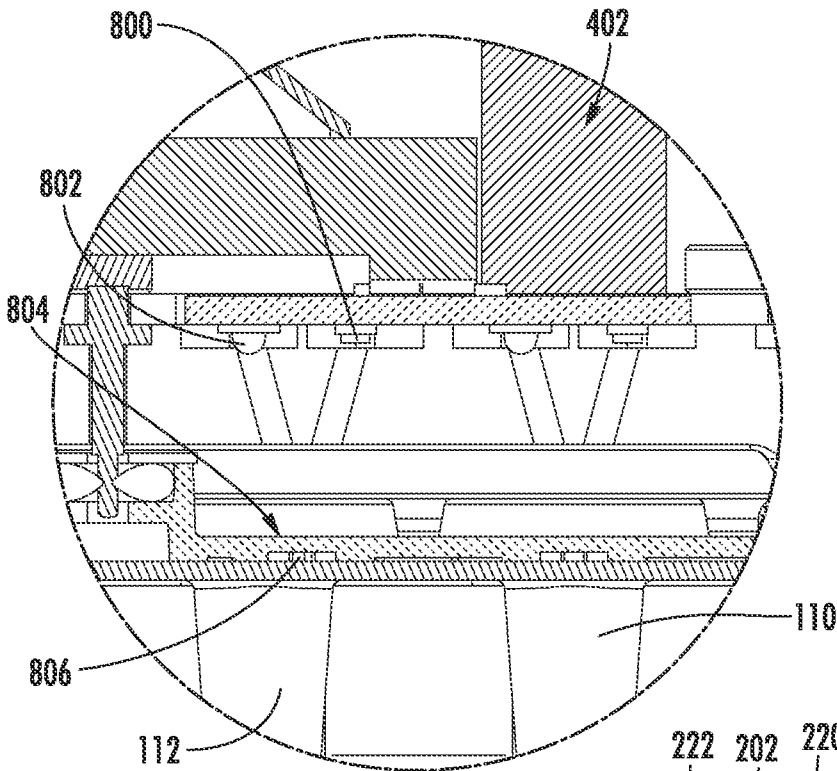

FIG. 8C

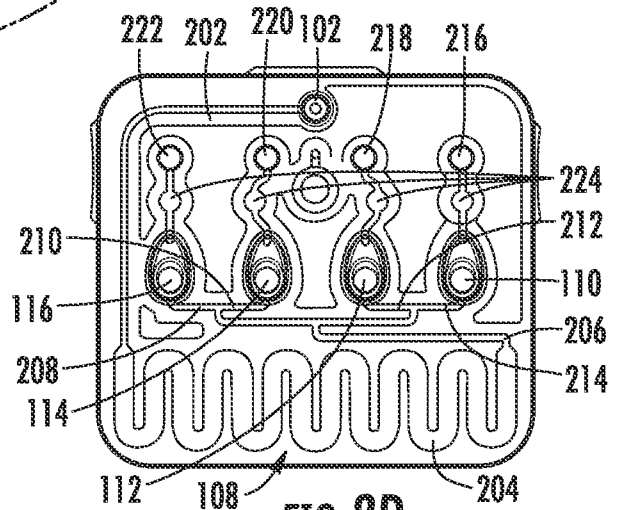

FIG. 8D

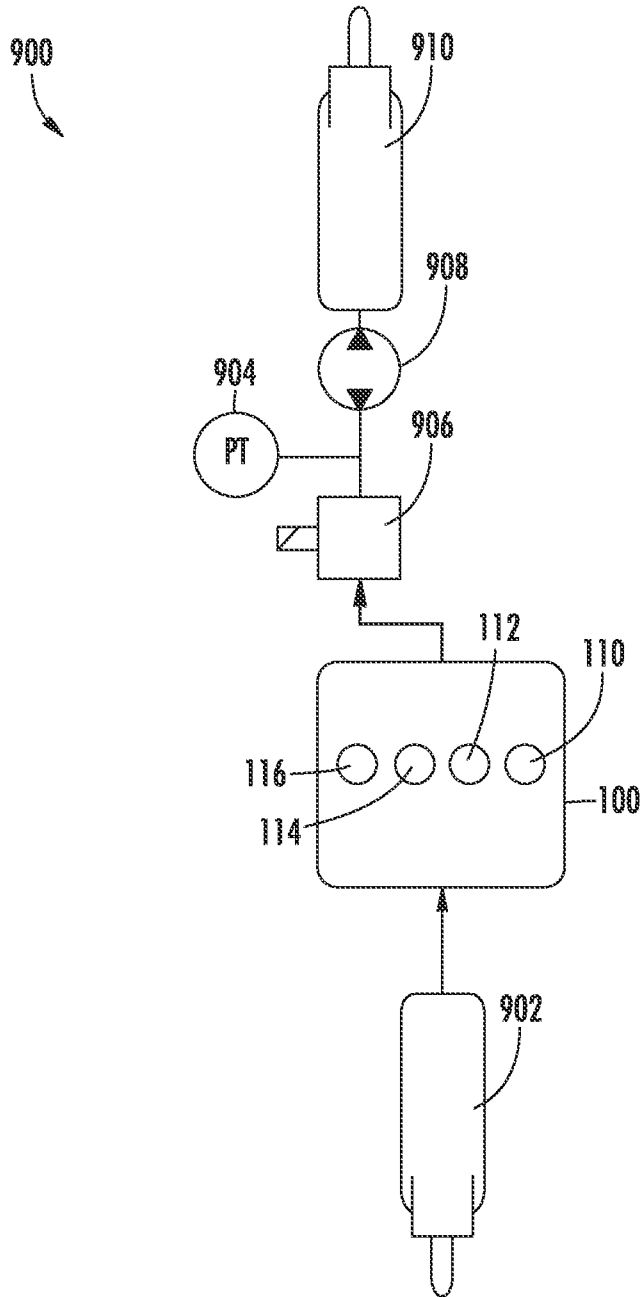

FIG. 9A

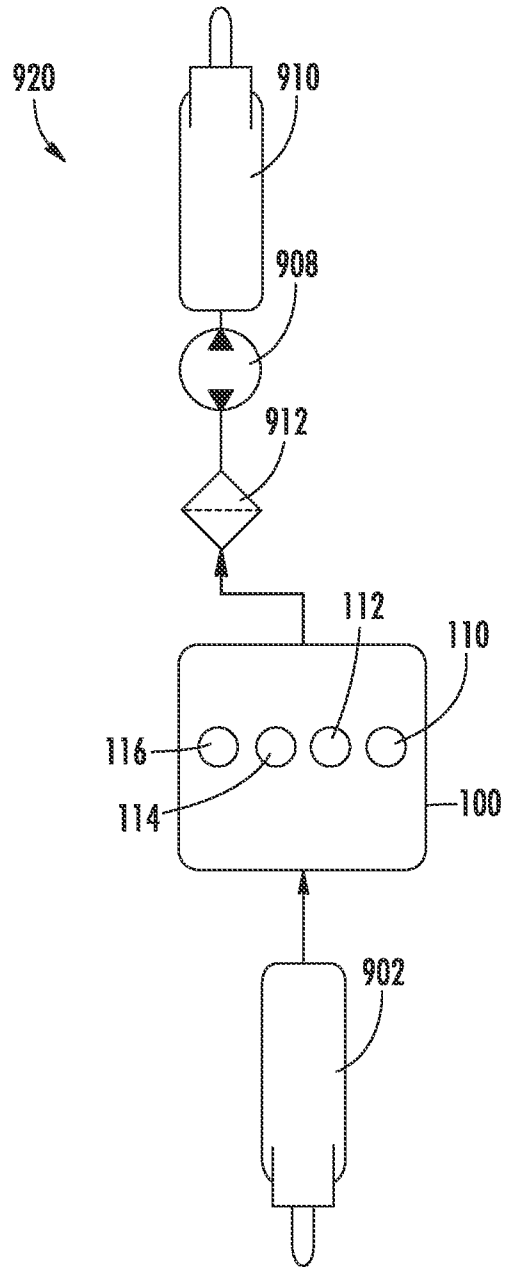

FIG. 9B

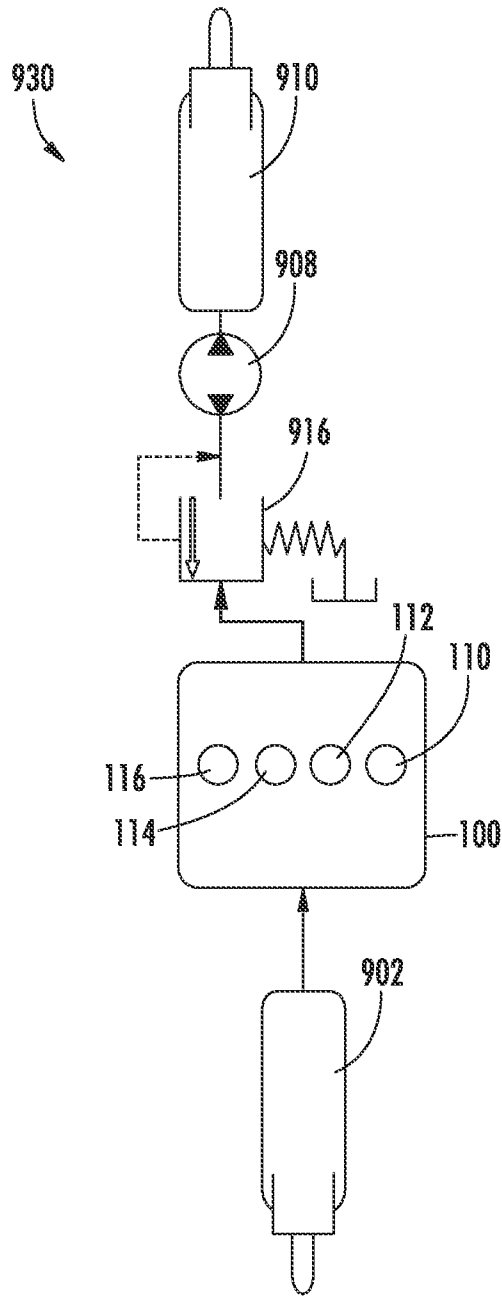

FIG. 9C

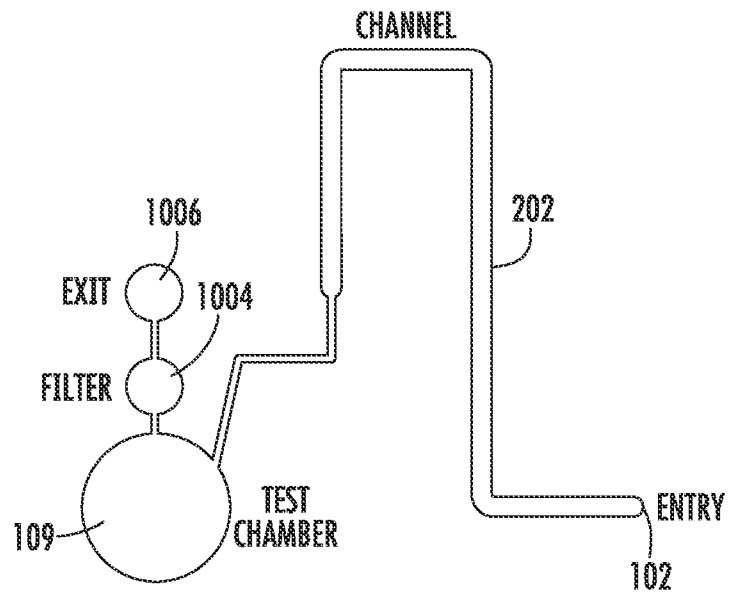

FIG. 10A

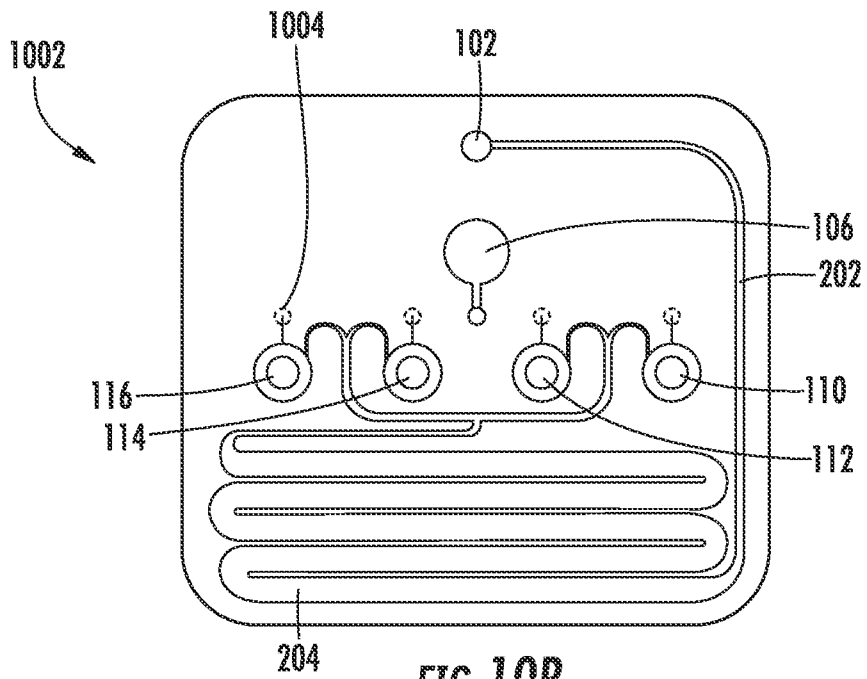

FIG. 10B

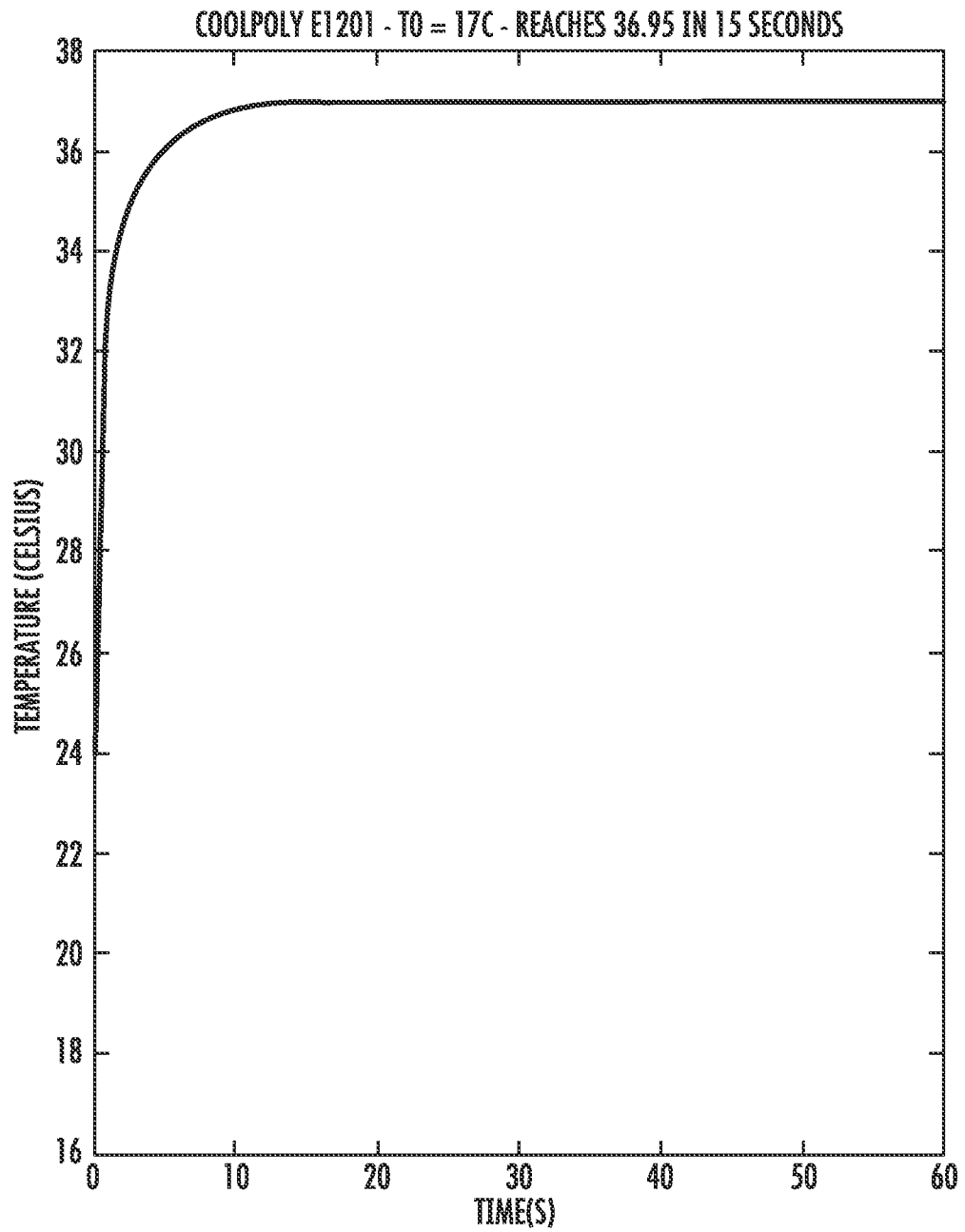

FIG. 11

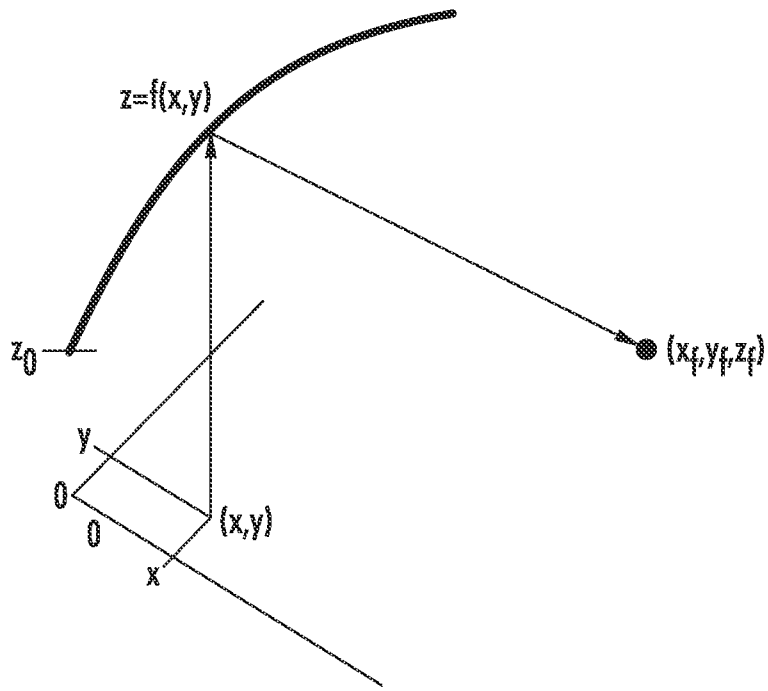

FIG. 12A

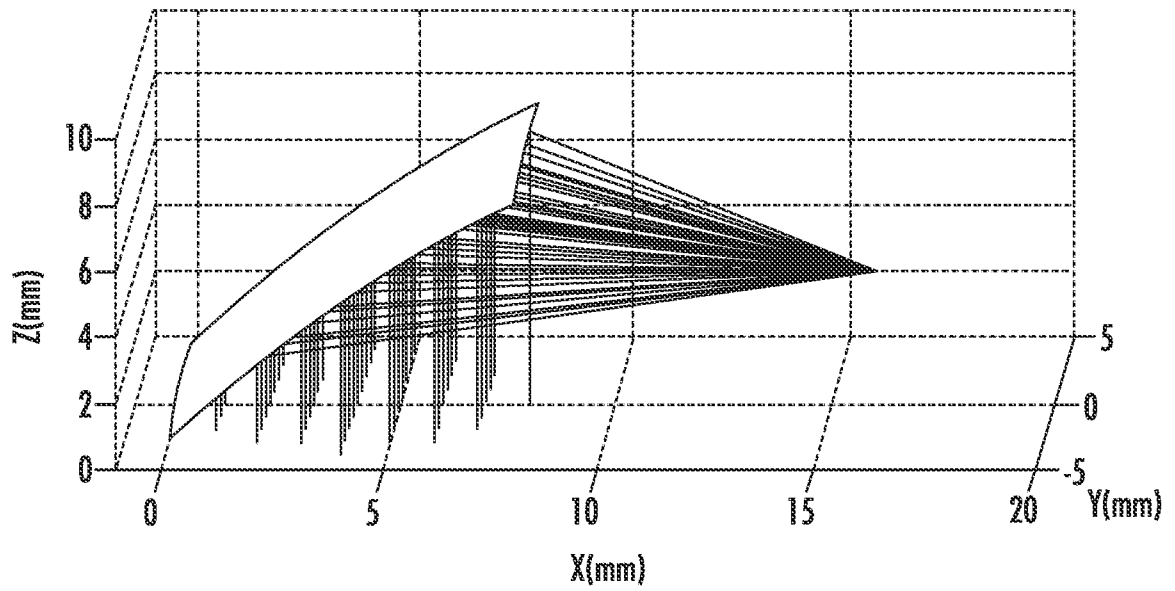

FIG. 12B

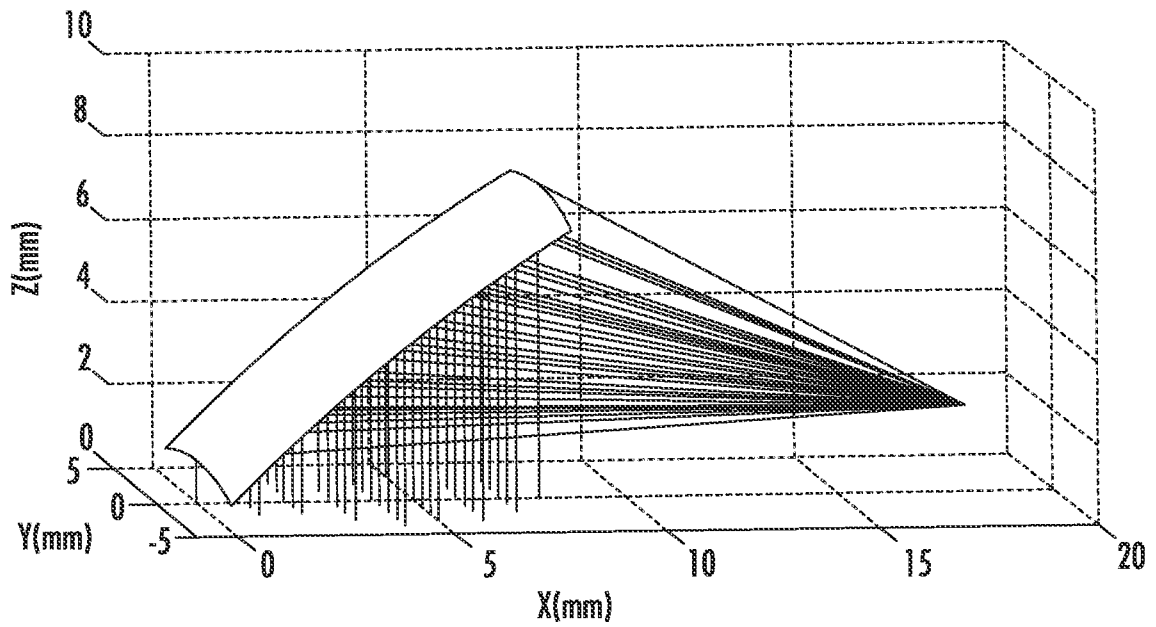

FIG. 12C