

March 5, 1957

C. D. SCOTT

2,783,636

PIN TUMBLER LOCK MECHANISM

Filed July 30, 1953

2 Sheets-Sheet 1

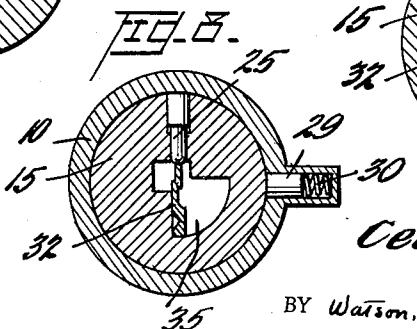
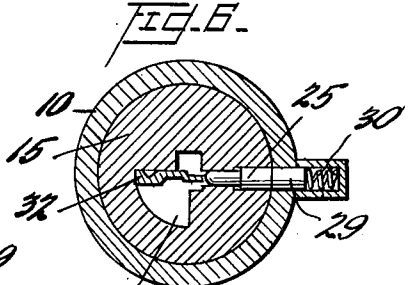
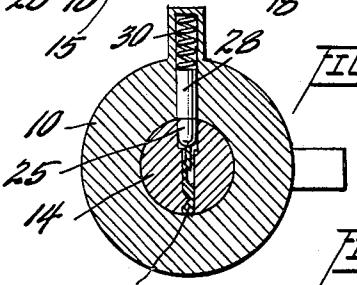
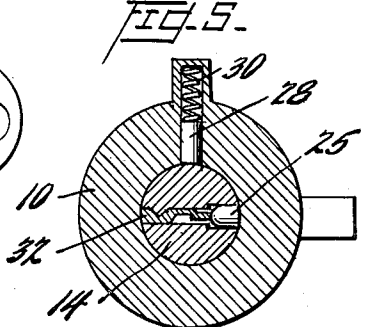
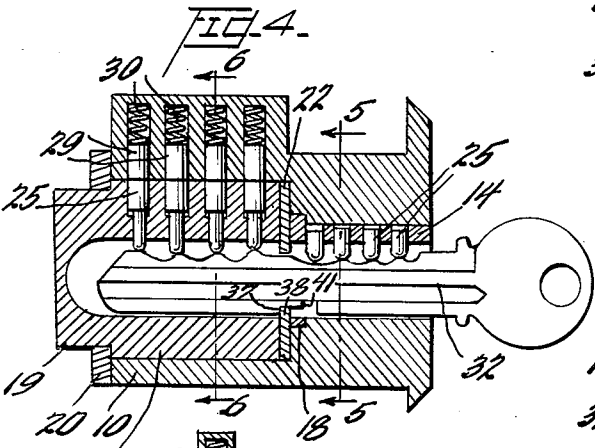
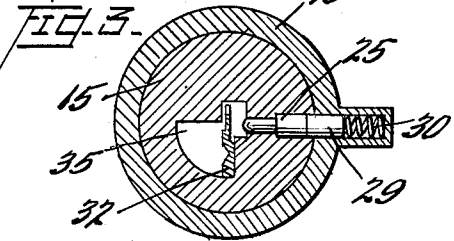
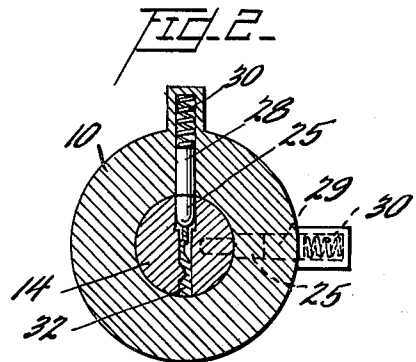
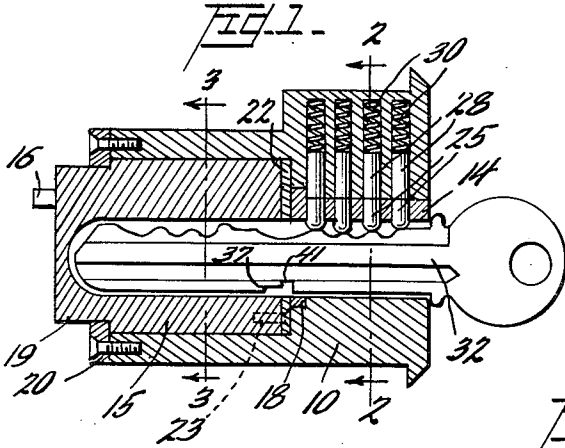

INVENTOR

Cecil D. Scott,

BY Watson, Cole, Grindle & Watson
ATTORNEY

March 5, 1957

C. D. SCOTT

2,783,636

PIN TUMBLER LOCK MECHANISM

Filed July 30, 1953

2 Sheets-Sheet 2

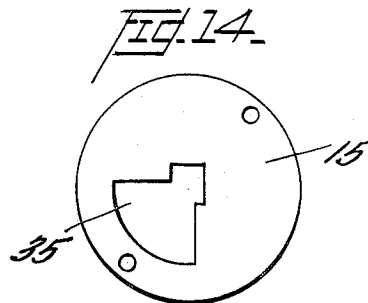
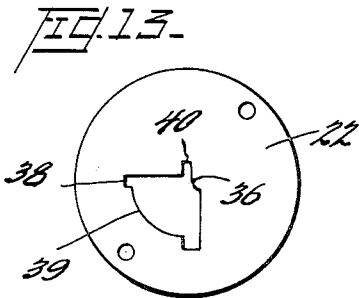
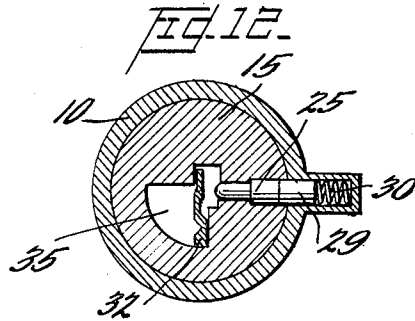
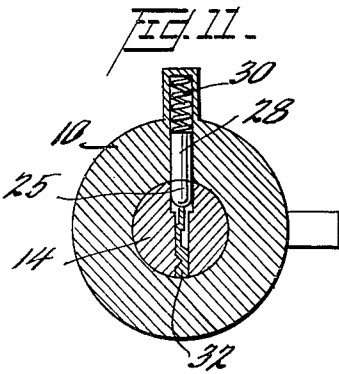
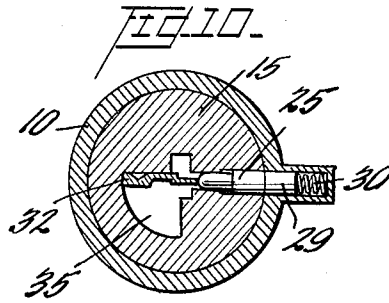
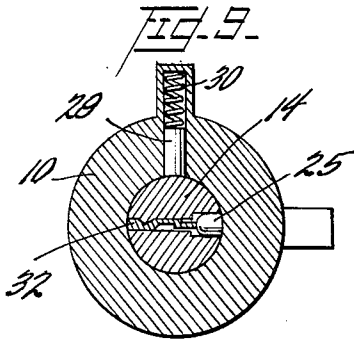

INVENTOR

Cecil D. Scott,

BY *Watson, Cole, Grindle & Watson*

ATTORNEY

1

2

2,783,636

PIN TUMBLER LOCK MECHANISM

Cecil D. Scott, Durham, N. C.

Application July 30, 1953, Serial No. 371,334

8 Claims. (Cl. 70—347)

This invention relates to pin tumbler locks and has for its object the provision of lock mechanism which will not respond to the numerous unauthorized methods of opening locks of this character and which is especially resistant to the technique of "picking."

Picking of a pin tumbler lock mechanism is commonly effected, with no great difficulty by experienced persons, by applying tension tending to rotate the locked barrel, each tumbler being successively raised to the barrel releasing position and being held in that position by the applied tension until the next succeeding tumbler is raised. When all of the tumblers have been raised by the required amount, the barrel may, of course, be rotated and the latch thereby released. For convenience, the conventional cooperating tumbler elements are called herein the pin and the driver, the latter term being applied to the outer of the two elements which is urged radially inward by a spring.

In accordance with the present invention, the lock mechanism is provided with two barrels in end-to-end relation, each barrel being provided with the usual row of pin receiving bores. The casing in which the barrels are rotatably mounted is also provided with two rows of driver receiving bores these last named rows of bores being angularly related, so that pin and driver alignment is established in one angular position for the first barrel and in another angular position for the second barrel. Consequently, when the first or front barrel occupies the position in which a key or a picking tool can be inserted, and the tumblers raised to release that barrel, the pin receiving bores of the second or rear barrel are out of alignment with the cooperating row of driver receiving bores in the casing, so that the tumblers in the rear barrel cannot be manipulated. Furthermore, when the front barrel has been released and rotated so as to align the keyway of the front barrel with the tumblers of the rear barrel, an intercepting guard or ward, extending between the two barrels, prevents access by a picking tool to the tumblers of the rear barrel.

More specifically, the invention contemplates the provision, in a pin tumbler lock mechanism, of a casing having a pair of key receiving barrels supported therein in end-to-end relation for relative rotation on a common axis, each barrel having a row of pin receiving bores. Cooperating driver receiving bores are formed in the casing, the latter being arranged in two axially and angularly displaced rows, each row cooperating with the pin receiving bores of one of said barrels. The barrels are provided with keyways, the keyway in the rear barrel being enlarged so as to permit the rotation therein of an inserteed key through an angle corresponding to the angular displacement of the two rows of driver receiving bores. Thus to unlock the mechanism by a key, the key is inserted in the usual way to its full length whereupon the tumblers in the front barrel are released. The front barrel is then rotated by turning the key to that position in which the key is in alignment with the tumblers of the rear barrel, whereupon the rear barrel may be released and both barrels turned together. Latch operating means carried

by the rear barrel then releases the latch in the conventional manner.

In the preferred form of the invention, the key may occupy either of two positions, a fully inserted position for releasing the tumblers of the front barrel, and a slightly withdrawn position for releasing the tumblers of the rear barrel. Thus the key is first inserted to the full depth to rotate the front barrel to align its keyway with the tumblers of the rear barrel. When this position is reached, the key is partially withdrawn to raise the tumblers in the rear barrel by the amount necessary to release the rear barrel, so that the latter may rotate further, together with the front barrel, into latch releasing position, which corresponds to the tumbler locking position for the front barrel. In order that the latch may again be rendered operative and the key withdrawn, the key must be again inserted to the full depth to release and rotate the front barrel beyond the tumbler locking position and concurrently to rotate the rear barrel into the tumbler locking position. The key is then turned reversely to rotate the front barrel into the tumbler locking position, whereupon the key may be withdrawn, leaving the mechanism in a locked condition and the latch operative.

Further objects and features of the invention will be apparent from the following description, relating to the accompanying drawing, in which is illustrated a preferred embodiment of the invention, it being understood that no limitation of the scope of the invention as defined in the appended claims is thereby intended. In the drawing:

Figure 1 is a vertical longitudinal section of a lock mechanism embodying the invention, showing the key fully inserted to raise the tumblers of the front barrel;

Figure 2 is a transverse section on the line 2—2 of Figure 1;

Figure 3 is a transverse section on the line 3—3 of Figure 1;

Figure 4 is a horizontal longitudinal section of the mechanism shown in Figure 1, the key having been rotated through 90° in a clockwise direction and partially withdrawn to raise the tumblers of the rear barrel;

Figure 5 is a transverse section on the line 5—5 of Figure 4;

Figure 6 is a transverse section on the line 6—6 of Figure 4;

Figure 7 is a transverse section corresponding to Figure 5 after further rotation of the key through 270° in a clockwise direction and full insertion thereof to release the tumblers of the front barrel;

Figure 8 is a transverse section corresponding to Figure 6 after such further rotation and full insertion of the key;

Figures 9 and 10 are views corresponding respectively to Figures 7 and 8 following still further rotation of the key in a clockwise direction through 90°;

Figures 11 and 12 correspond respectively to Figures 9 and 10 following rotation of the key in a counterclockwise direction through 90°;

Figure 13 is a front elevation of the ward extending between the barrels and

Figure 14 is a front elevation of the rear barrel.

The mechanism illustrated in the drawings comprises a lock casing 10 provided with coaxial cylindrical bores in which are received, in end-to-end relation, a front barrel 14 and a rear barrel 15, the two barrels being received snugly with the bores so as to be freely rotatable therein. The rear barrel 15 is provided with the conventional latch actuating means, represented by the pin 16, whereby latch mechanism, not shown, may be released upon rotation of the barrel 15 to a predetermined angular position in the usual manner. The barrels are preferably assembled in the casing by insertion from the rear of the latter and are so formed as to

prevent their withdrawal from the front of the lock mechanism. For this purpose, the barrel 14 may be provided at its rear end with a flanged portion 18 which may be either integral with the barrel or secured thereto, the flanged portion 18 of the barrel being received in an enlarged recess in the casing 10, the periphery of the flanged portion being circular and coaxial with the body of the barrel 14. The rear barrel 15 is preferably of larger diameter than the barrel 14, so as to prevent withdrawal thereof through the bore in which barrel 14 is supported, as well as to afford added strength. Rear barrel 15 may be reduced in diameter at its rearward end, as indicated at 19, to receive an annular plate 20 which is bolted or otherwise secured to the rear end of casing 10 to retain barrel 15 against rearward displacement. Interposed between the barrels 14 and 15 and secured to the latter by bolts 23 or otherwise is a guard plate or ward 22, shown more particularly in Figure 13, to impede access to the rear barrel 15 from the front of the mechanism as hereinafter described. The ward may be formed of drill resistant metal, such as hardened steel, if desired.

Each of the barrels is provided with the conventional radial tumbler recesses or pin receiving bores in which the usual pins 25 are slidably received, and cooperating driver receiving bores are formed in casing 10, the driver receiving bores being arranged in two rows which are angularly displaced, each with respect to the other, each row cooperating with the pin receiving bores of one of said barrels. The angular relation between the two rows of driver receiving bores may be selected arbitrarily, preferably varying from lock to lock as an added obstacle to unauthorized manipulation; an angle of 90° is selected for the purpose of illustration. The drivers cooperating with the pins of the front barrel are shown at 28 and the drivers cooperating with the pins of the rear barrel at 29, the usual springs 30, positioned in the driver receiving bores, urging the drivers radially inwardly. As in the conventional lock mechanism, each barrel may be freely rotated in its seat in the casing 10 when the pins supported in that barrel have all been displaced radially to such an extent that the outer end of each pin is positioned on the periphery of the barrel, and the contour of the key 32 is such that when the key is properly positioned, the tumblers will be displaced to release the barrel for rotation in the usual manner, each barrel being provided with a longitudinal keyway to permit insertion and withdrawal of the key 32.

Since the driver receiving bores for the two barrels are angularly related, it is necessary so to construct the lock that the front barrel 14 may be rotated by the key 32 into the tumbler releasing position for the rear barrel 15 while the latter remains locked. To this end I may enlarge the keyway for the rear barrel 15, as indicated at 35, the enlargement of the keyway being sufficient, in the illustrated embodiment, to permit rotation of the key freely within the rear barrel 15 through an angle of 90°. The keyway for the front barrel may be of conventional design, the key having the usual sliding fit therein.

As an added precaution against tampering, I may so form the key that the front barrel 14 is released for rotation only when the key is fully inserted, as in Figure 1, whereas the rear barrel 15 is released for rotation only when the key is partially withdrawn, as in Figure 4. In this event it is necessary, of course, to dimension the tumblers for the respective barrel in such manner that the key can be moved freely from the fully inserted to the partially released position when either barrel has been rotated away from that position in which its pins and the cooperating drivers are in alignment, but this is readily achieved.

In order that the ward 22 may effectively block access to the tumblers of the rear barrel 15, it is so shaped

as to extend partly across and to screen that part of the keyway for the rear barrel which is in alignment with the pins of that barrel, while permitting free insertion of the key in the initial locked position of the mechanism. This may be understood by comparing Figures 1 and 4, the opening in ward 22 being relieved as shown in Figure 1, and as indicated at 40 in Figure 13, to permit free insertion of the key and being formed to extend inwardly as shown in Figure 4 and as indicated at 36 in Figure 13 so as to reduce the size of the access opening in the plane of the tumblers for the rear barrel 15. It will be observed that the portion 38 of the ward also serves as an abutment for engagement by cooperating shoulder 37 on the key 32 when the key is in the partially withdrawn position, so as to define that position and thus to facilitate the correct endwise displacement of the key for the release of the rear barrel. The intermediate portion 39 of the ward, by virtue of engagement with shoulder 41 on the key, prevents even partial withdrawal of the key during the initial clockwise rotation thereof. This contour for the ward is permissible because the key is invariably inserted in a plane which is angularly related to the plane containing the drivers for the rear barrel, and is rotated into the last named plane for the purpose of releasing the rear barrel, so that only the central portion of the key need clear the tumbler obstructing portion of the ward 22.

It will also be observed that when the front barrel has been rotated from barrel releasing position, the pins for that barrel can no longer be radially displaced, and thus serve as a further obstacle to the picking of the tumblers of the rear barrel, so that the angular relation of the drivers for the two barrels is in itself a protective feature, apart from the function of the ward 22.

It will be appreciated from the foregoing description that the lock may readily be operated by a suitable key in the following manner. With the lock in the position shown in Figure 1, and the key fully inserted, the pins 25 for the front barrel 14 are displaced radially, together with the associated drivers 28, to release the front barrel 14 for rotation. The key and the front barrel may then be rotated through 90° from the position shown in Figures 1 to 3 to the position shown in Figures 4 to 6, and the key partially withdrawn as shown in Figure 4 whereby the tumblers for the rear barrel 15 are positioned to release the rear barrel for rotation. The key may now be turned through 270°, together with both barrels, to the position shown in Figures 7 and 8. At this position of the rear barrel 15, the latch, not shown, is released in conventional manner, for instance by pin 16, and the front barrel 14 is again in that position in which the pins 25 cooperate with the drivers 28. Since the front barrel 14 is locked in this position, the key is again fully inserted to release the front barrel, which may then be turned through 90° in a clockwise direction, together with both barrels. The rear barrel 15 is now in the locked position and the latch is again rendered operative. In order to effect locking of the front barrel 14, the key is then rotated with the latter in a counterclockwise direction through 90°, the key being then in the initial position so that it may be withdrawn from the lock, both barrels being locked against rotation and the latch being rendered operative.

Having thus described the invention, what is claimed as new and desired to be secured by Letters Patent is:

1. In a pin tumbler lock, the combination with a casing, of a pair of key receiving barrels supported in end-to-end relation in said casing for relative rotation on a common axis, a row of pin receiving bores formed in each of said barrels, driver receiving bores formed in said casing and arranged in two axially and angularly displaced rows, the pin receiving bores in each barrel being alignable with the corresponding bores in one of said rows of driver receiving bores on rotation of the barrel, a cooperating driver and pin slidably mounted in each alignable pair

5

6

of bores, said barrels having axial keyways, the keyway in the rear barrel being enlarged to permit rotation of the key therein through an angle corresponding to the angular displacement of said rows of driver receiving bores.

2. In a pin tumbler lock, the combination with a casing, of a pair of key receiving barrels supported in end-to-end relation in said casing for relative rotation on a common axis, a row of pin receiving bores formed in each of said barrels, driver receiving bores formed in said casing and arranged in two axially and angularly displaced rows, the pin receiving bores in each barrel being alignable with the corresponding bores in one of said rows of driver receiving bores on rotation of the barrel, a cooperating driver and pin slidably mounted in each alignable pair of bores, said barrels having axial keyways, the keyway in the rear barrel being enlarged to permit rotation of the key therein through an angle corresponding to the angular displacement of said rows of driver receiving bores, and a ward between said barrels extending across part of the keyway in the inner barrel to impede unauthorized access to the latter.

3. In a pin tumbler lock, the combination with a casing, of a pair of key receiving barrels supported in end-to-end relation in said casing for relative rotation on a common axis, a row of pin receiving bores formed in each of said barrels, driver receiving bores formed in said casing and arranged in two axially and angularly displaced rows, the pin receiving bores in each barrel being alignable with the corresponding bores in one of said rows of driver receiving bores on rotation of the barrel, a cooperating driver and pin slidably mounted in each alignable pair of bores, said barrels having axial keyways, the keyway in the rear barrel being enlarged to permit rotation of the key therein through an angle corresponding to the angular displacement of said rows of driver receiving bores, and a ward between said barrels and secured to the rear barrel, said ward extending across part of the keyway in the rear barrel in the plane containing the pin receiving bores of the rear barrel to block access to the pins of the rear barrel.

4. In a pin tumbler lock, the combination with a casing, of a pair of key receiving barrels supported in end-to-end relation in said casing for relative rotation on a common axis, a row of pin receiving bores formed in each of said barrels, driver receiving bores formed in said casing and arranged in two axially and angularly displaced rows, only one such row being provided for cooperation with each barrel, the pin receiving bores in each barrel being alignable with the corresponding bores in one of said rows of driver receiving bores on rotation of the barrel, and a cooperating driver and pin slidably mounted in each alignable pair of bores, said barrels having axial keyways, one of said keyways being enlarged to permit rotation of a key therein through an angle corresponding to the angular displacement of said driver receiving bores.

5. In a pin tumbler lock, the combination with a casing, of a pair of key receiving barrels supported in end-to-end relation in said casing for relative rotation on a common axis, a row of pin receiving bores formed in each of said barrels, driver receiving bores formed in said casing and arranged in two axially and angularly displaced rows, only one such row being provided for cooperation with each barrel, the pin receiving bores in each barrel being alignable with the corresponding bores in one of said rows of driver receiving bores on rotation of the barrel, tumblers including a cooperating pin and driver in the alignable bores and a key insertable in said keyways, said key having a configuration such that

the tumblers of one barrel are released only on full insertion of the key, whereas the tumblers of the other barrel are released only when the key is partially inserted.

6. In a pin tumbler lock, the combination with a casing, of a pair of key receiving barrels supported in end-to-end relation in said casing for relative rotation on a common axis, a row of pin receiving bores formed in each of said barrels, driver receiving bores formed in said casing and arranged in two axially and angularly displaced rows, only one such row being provided for cooperation with each barrel, the pin receiving bores in each barrel being alignable with the corresponding bores in one of said rows of driver receiving bores on rotation of the barrel, tumblers including a cooperating pin and driver in the alignable bores and a key insertable in said keyways, said key having a configuration such that the tumblers of one barrel are released only on full insertion of the key, whereas the tumblers of the other barrel are released only when the key is partially inserted, and a ward positioned between said barrels, said ward having a part for engagement with said key on displacement of the latter to partially inserted position to limit such displacement and define the said position.

7. In a pin tumbler lock, the combination with a casing, of a pair of key receiving barrels supported in end-to-end relation in said casing for relative rotation on a common axis, a row of pin receiving bores formed in each of said barrels, driver receiving bores formed in said casing and arranged in two axially and angularly displaced rows, only one such row being provided for cooperation with each barrel, the pin receiving bores in each barrel being alignable with the corresponding bores in one of said rows of driver receiving bores on rotation of the barrel, and a cooperating driver and pin slidably mounted in each alignable pair of bores, said barrels having axial keyways, one of said keyways being enlarged to permit rotation of a key therein through an angle corresponding to the angular displacement of said driver receiving bores, said rear barrel being larger in diameter than said front barrel.

8. In a pin tumbler lock, the combination with a casing, of a pair of key receiving barrels supported in end-to-end relation in said casing for relative rotation on a common axis, a row of pin receiving bores formed in each of said barrels, driver receiving bores formed in said casing and arranged in two axially and angularly displaced rows, the pin receiving bores in each barrel being alignable with the corresponding bores in one of said rows of driver receiving bores on rotation of the barrel, a cooperating driver and pin slidably mounted in each alignable pair of bores, said barrels having axial keyways, the keyway in the rear barrel being enlarged to permit rotation of the key therein through an angle corresponding to the angular displacement of said rows of driver receiving bores, and means fixed to said rear barrel for preventing withdrawal of a key from said lock mechanism when said rear barrel is in pin and driver aligned position.

References Cited in the file of this patent

UNITED STATES PATENTS

65	1,414,348	Falk -----	May 2, 1922
	1,990,933	Falk -----	Feb. 12, 1935
	2,061,354	Federholzner -----	Nov. 17, 1936
	2,101,779	Kenney -----	Dec. 7, 1937
	2,199,165	Smith -----	Apr. 30, 1940
70	2,246,112	Speer -----	June 17, 1941
	2,552,012	O'Kane -----	May 8, 1951