

R. T. COLLIS.

Fire-Back and Grate-Setting.

No. 130,195.

Patented Aug. 6, 1872.

Fig. 1

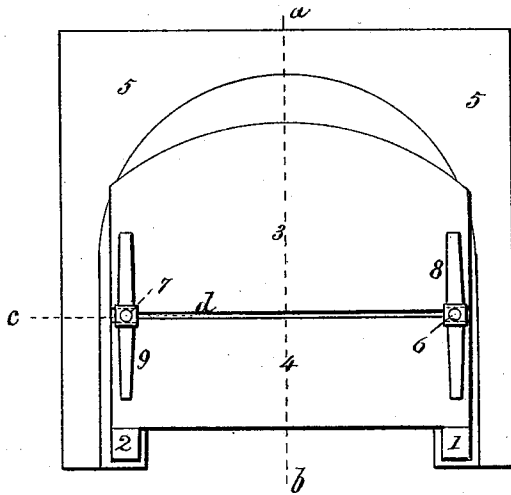

Fig. 2

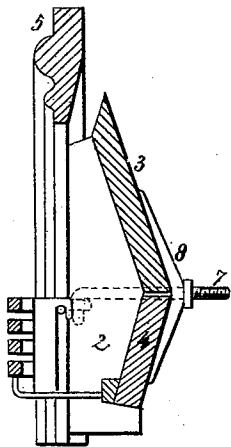

Fig. 3

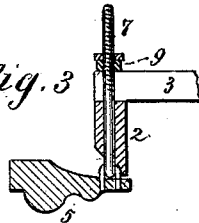
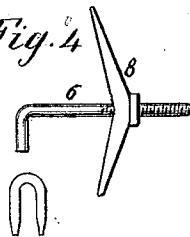

Fig. 4



Witnesses  
W. H. Blodgett  
John J. Crane

Inventor  
Royal T. Collis  
per Edw. W. Down  
Dftm.

# UNITED STATES PATENT OFFICE.

ROYAL T. COLLIS, OF WEBSTER, OHIO.

## IMPROVEMENT IN FIRE-BACKS AND GRATE-SETTINGS.

Specification forming part of Letters Patent No. 130,195, dated August 6, 1872.

Specification describing certain Improvements in Fire-Backs and Grate-Settings, by ROYAL T. COLLIS, of Webster, Scioto county, Ohio.

My invention relates to the construction of fire-places—"fire-back and grate-settings"—of tiles made of fire-clay and burned in a kiln, and fastened together by means of clamps, bolts, and screws, so as to form a solid self-supporting fire-place without the use of mortar.

Figure 1 in the drawing represents a back view of the setting when fastened together. 1 and 2 of Fig. 1 show the rear projection of the side tile or jambs, on which the lower back tile rests. 3 is the upper back tile, inclining forward and resting on the slope of the side tiles, and held firmly in place by means hereinafter described. In referring to 6 and 7, 4 is the lower back tile resting on projections 1 and 2, and held by the same fastening as 3, (upper back tile.) 5 is the front casting, of iron. 6 and 7 are the bolts, with hooks at one end entering the staples, which are either molded in the front or fastened by drilling holes and passing through holes molded in the side tiles, and through mortises in the joint between the upper and lower back tiles, and receiving in the other ends clamps and taps, and having a screw fitting the taps, by which means the clamps are drawn against the back tile, and the whole setting held together. 8 8 are the

clamps for holding the tile. 9 is the tap for drawing down and tightening the clamps.

Fig. 2 represents a transverse section of Fig. 1 as exposed to view in cutting Fig. 1 by the vertical line *a b*, and showing by dotted line the direction in which the bolts pass through the side tile, the figures referring to the same parts as in Fig. 1.

Fig. 3 represents a section of the side of the setting, or of Fig. 2 as exposed to view by cutting the side, or Fig. 2 by the lateral line *c d*, as shown in Fig. 1, the figures referring to the same parts.

Fig. 4 represents the bolt 6, and screw with the clamp 8, and tap and the staple, all referred to in connection with the other figures.

I claim as my invention—

1. The side tiles, perforated as shown, when combined with front and back in manner described.
2. The back tiles 3 and 4 and the bolts, clamps, and taps, when arranged and combined in manner shown.
3. The setting herein described, when the several parts are constructed as set forth, so that the whole can be held firmly in place without masonry.

ROYAL T. COLLIS.

Witnesses:

NOAH J. DEVER,  
F. C. SEARL.