

S. D. Williamson,
Roller for Boxes, &c.

N^o 2,945. Patented Feb. 4, 1843.

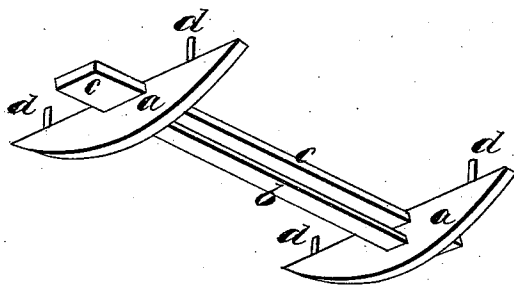
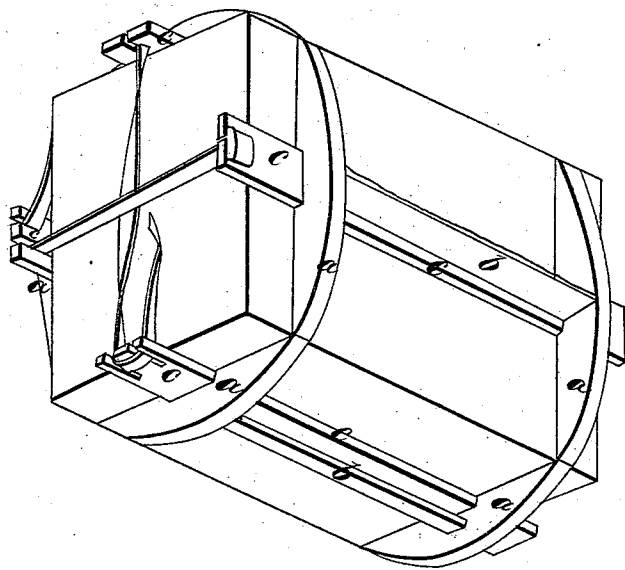

UNITED STATES PATENT OFFICE.

STEPHEN D. WILLIAMSON, OF ANDERSON TOWNSHIP, HAMILTON COUNTY, OHIO.

METHOD OF REMOVING SQUARE AND OTHER PRISMATIC BOXES AND OTHER BODIES.

Specification of Letters Patent No. 2,945, dated February 4, 1843.

To all whom it may concern:

Be it known that I, STEPHEN D. WILLIAMSON, of Anderson township, in the county of Hamilton and State of Ohio, have invented a new and useful Improvement in Removing Cubical or Prismatic Bodies, such as Bales, Boxes, Stones, &c.; and I do hereby declare that the following is a full, clear, and exact description thereof, reference being had to the accompanying drawing, in which—

Figure 1, is an isometrical view; Fig. 2, segments or rockers detached.

The nature of my invention consists in attaching to the sides of prismatic bodies segments of a circle large enough to circumscribe such prisms. These segments formed of any proper material are placed one at each end on each of the sides of the package to be moved and serve to convert it from a prismatic into a cylindrical body for the purpose of removing it with facility.

In forming this apparatus pieces of plank of suitable thickness should be cut into segments (*a*) and connected in pairs, parallel to each other, by means of cross braces (*b*)

or any similar way; so as to prevent their derangement by lateral pressure; they also have a bar (*c*) let into them, even with the inner face; this bar may extend beyond the end of the package, and serve to fasten the segments to the side of the package, by means of a cord, or other proper fastening, connecting it with a similar bar on the opposite side—or the segments may be attached where the nature of the package will admit by sharp iron points (*d*), projecting from thin chord or inner face.

Packages can be thus moved with ease and safety not being subject to the shocks occasioned in turning them over on their flat sides.

What I claim as my invention and desire to secure by Letters Patent is—

The combination of the segments (*a*) with any plane sided bodies for the purpose of facilitating their removal, in the manner above described.

STEPHEN D. WILLIAMSON.

Witnesses:

J. J. GREENOUGH,
J. P. VAN TYNE.