

(19) World Intellectual Property
Organization
International Bureau



(43) International Publication Date
10 June 2004 (10.06.2004)

PCT

(10) International Publication Number
WO 2004/049392 A1

- (51) International Patent Classification⁷: H01K 1/24, 1/34, 1/58, 1/32, H01J 61/34, 61/52, F21V 29/00
- (71) Applicant (for AE only): U.S. PHILIPS CORPORATION [US/US]; 1251 Avenue of the Americas, New York, NY 10020 (US).
- (21) International Application Number: PCT/IB2003/005118
- (72) Inventors; and
- (75) Inventors/Applicants (for US only): HUIZAR, Jamie [MX/MX]; Ave. Parque Ind. Juarez No. 3951, 32630 Juarez (MX). JURADO, Victor [MX/MX]; Ave. Parque Ind. Juarez No. 3951, 32630 Juarez (MX). LOPEZ, Antonio [MX/MX]; Ave. Parque Inc. Juarez No. 3951, 32630 Juarez (MX).
- (22) International Filing Date: 7 November 2003 (07.11.2003)
- (25) Filing Language: English
- (26) Publication Language: English
- (74) Common Representative: KONINKLIJKE PHILIPS ELECTRONICS N.V.; c/o BARTLETT, Ernestine, P.O. Box 3001, Briarcliff Manor, NY 10510-8001 (US).
- (30) Priority Data: 60/429,741 27 November 2002 (27.11.2002) US
- (81) Designated States (national): AE, AG, AL, AM, AT, AU, AZ, BA, BB, BG, BR, BY, BZ, CA, CH, CN, CO, CR, CU, CZ, DE, DK, DM, DZ, EC, EE, EG, ES, FI, GB, GD, GE, GH, GM, HR, HU, ID, IL, IN, IS, JP, KE, KG, KP, KR, KZ, LC, LK, LR, LS, LT, LU, LV, MA, MD, MG, MK,
- (71) Applicant (for all designated States except US): KONINKLIJKE PHILIPS ELECTRONICS N.V. [NL/NL]; Groenewoudseweg 1, NL-5621 BA Eindhoven (NL).

[Continued on next page]

(54) Title: ELECTRIC LAMP/REFLECTOR UNIT

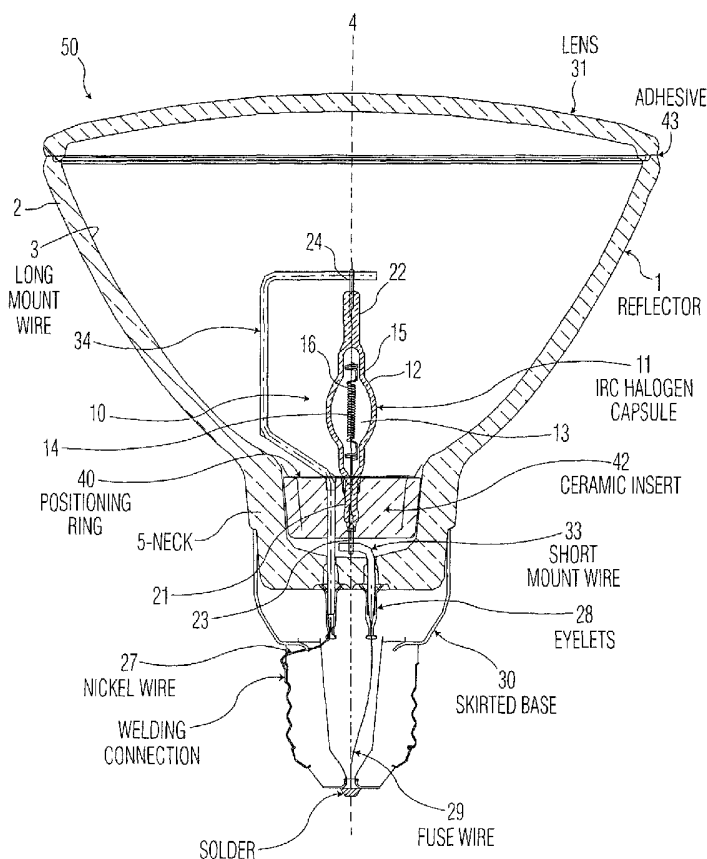

(57) Abstract: The invention provides a new PAR 38 lamp/reflector unit comprising a halogen lamp of suitable power, i.e. 100 watts/120 volts, coated with infrared film to reflect infrared energy produced by the halogen lamp back to the filament, making it more efficient; that meets and preferably exceeds the minimum EPACT efficacy standards, that exhibits a median life of at least about 3000 hours, while giving light output greater than 90% from the original value at about 1750 hours. Unit comprises a double-ended electric lamp (10) arranged in a reflector body (1) in a manner that first end portion (21) is at least partly situated in the neck-shaped portion (5), cavity (13) is situated within reflecting portion (2), the electric light source (16) is predominantly situated on the optical axis (4), a ceramic insert (42), beneath mounting ring (40) through which the seal of first end portion (21) is passed, is effective to dissipate heat from first end portion (21) during operation of the lamp.

WO 2004/049392 A1



MN, MW, MX, MZ, NI, NO, NZ, OM, PG, PH, PL, PT, RO, RU, SC, SD, SE, SG, SK, SL, SY, TJ, TM, TN, TR, TT, TZ, UA, UG, US, UZ, VC, VN, YU, ZA, ZM, ZW.

- (84) Designated States (regional):** ARIPO patent (BW, GH, GM, KE, LS, MW, MZ, SD, SL, SZ, TZ, UG, ZM, ZW), Eurasian patent (AM, AZ, BY, KG, KZ, MD, RU, TJ, TM), European patent (AT, BE, BG, CH, CY, CZ, DE, DK, EE, ES, FI, FR, GB, GR, HU, IE, IT, LU, MC, NL, PT, RO, SE, SI, SK, TR), OAPI patent (BF, BJ, CF, CG, CI, CM, GA, GN, GQ, GW, ML, MR, NE, SN, TD, TG).

Declaration under Rule 4.17:

- *as to applicant's entitlement to apply for and be granted a patent (Rule 4.17(ii)) for the following designations AE, AG, AL, AM, AT, AU, AZ, BA, BB, BG, BR, BY, BZ, CA, CH, CN, CO, CR, CU, CZ, DE, DK, DM, DZ, EC, EE, EG, ES, FI, GB, GD, GE, GH, GM, HR, HU, ID, IL, IN, IS, JP, KE,*

KG, KP, KR, KZ, LC, LK, LR, LS, LT, LU, LV, MA, MD, MG, MK, MN, MW, MX, MZ, NI, NO, NZ, OM, PG, PH, PL, PT, RO, RU, SC, SD, SE, SG, SK, SL, SY, TJ, TM, TN, TR, TT, TZ, UA, UG, UZ, VC, VN, YU, ZA, ZM, ZW, ARIPO patent (BW, GH, GM, KE, LS, MW, MZ, SD, SL, SZ, TZ, UG, ZM, ZW), Eurasian patent (AM, AZ, BY, KG, KZ, MD, RU, TJ, TM), European patent (AT, BE, BG, CH, CY, CZ, DE, DK, EE, ES, FI, FR, GB, GR, HU, IE, IT, LU, MC, NL, PT, RO, SE, SI, SK, TR), OAPI patent (BF, BJ, CF, CG, CI, CM, GA, GN, GQ, GW, ML, MR, NE, SN, TD, TG)

Published:

- *with international search report*

For two-letter codes and other abbreviations, refer to the "Guidance Notes on Codes and Abbreviations" appearing at the beginning of each regular issue of the PCT Gazette.

ELECTRIC LAMP/REFLECTOR UNIT

The invention relates to an electric lamp/reflector unit comprising a reflector body including a reflector portion having a concave reflecting surface with an optical axis and, integral therewith, a hollow neck-shaped portion about the optical axis, an electric lamp
5 provided with a gastight light-transmitting lamp vessel which comprises: a quartz-glass wall which encloses a cavity of a predetermined, in general, spherical or elliptic shape with a geometric center, said quartz-glass wall being at least partly provided with an infrared-reflecting and visible light-transmitting coating, said cavity accommodating a substantially linear electric light source, a metal foil which is entirely embedded in the quartz-glass wall
10 and connected to the electric light source, a first end portion and a second end portion which are arranged so as to be opposite to each other and which both comprise a seal, through which seals a respective current conductor, which is connected to the embedded metal foil, issues from the lamp vessel to the exterior.

The invention further relates to an electric lamp for use in an electric lamp/reflector
15 unit.

Such electric lamp/reflector units are used as a source of white light for general and decorative lighting applications to show objects in their true colors.

Such a lamp is well known in the lighting industry and includes, for example, an electric lamp/reflector unit of the type mentioned in EP-A 0 397 422. In said document a
20 description is given of a so-called double-ended halogen lamp provided with an infrared-reflecting interference filter, which lamp is arranged in a reflector body of the PAR 38 type, where the abbreviation PAR stands for Parabolic Aluminum Reflector, and the number "38" indicates a diameter of the reflector body at the location of the light emission window, the diameter being obtained by multiplying said number with an eighth of an inch,
25 1 inch being 25.4 mm, so that the diameter of the emission window of a PAR 38 reflector is $38 \times 1/8$ inch or approximately 121 mm.

As part of a worldwide movement towards more energy efficient lighting, in more recent years government legislation in the United States (commonly referred to as the national Energy Policy Act "EPACT") has mandated lamp efficacy values for many types
30 of commonly used lamps including PAR lamps. Only products meeting these efficacy levels may be sold in the United States. These minimum efficacy values for PAR-38 incandescent lamps are for example, lamps of 51-66 W must achieve 11 lumens per Watt

(LPW), lamps of 67-85W must achieve 12.5 LPW, lamps of 86-115W must achieve 14 LPW, and lamps in the range of 116-155W must achieve 14.5 LPW. It is possible to design a lamp for a conventional PAR-38 lamp that will meet EPACT standards.

However, designing such a lamp heretofore has resulted in a greatly reduced lamp life.

5 This is attributed to the fact that while the IR-coated burner has a higher brightness and a higher luminous efficacy, the seal of the lamp vessel assumes a comparatively high temperature during operation which high temperature results in shortened lamp life. Another cause of the short life of halogen lamps is molybdenum corrosion. For these and other reasons, as the press temperature increases, the possibility of the lamp failing early
10 increases as well.

U.S. Patent 5,646,473, titled "ELECTRIC REFLECTOR LAMP", issued July 8, 1997 and assigned to the same assignee as in the present application, relates to an electric reflector lamp in which the lamp vessel contains a light source that may be, for example, an incandescent body in a gas comprising halogen and may be covered with an IR-reflecting
15 interference filter. The lamp also comprises a ceramic body which surrounds the seal to lower the temperature during operation. Such lamps are disclosed to be of relatively low power, for example, 75 W for a lamp without an IR-reflecting interference filter, and 68W for a lamp without an IR-reflecting interference filter, when operated at mains voltage. The lamp life and efficacy of such lamps are not disclosed.

20 U.S. Patent 5,281,889 issued January 25, 1994 and assigned to a predecessor company of the assignee in the present application, discloses a reflector lamp of the PAR 16 dimension having a bipartite neck. The mounting member, a plate with resilient tags which hold the seal with clamping force, is enclosed between the two parts of the neck. Such a lamp comprises a ceramic extender assembled on and glued to the reflector.

25 There is a need in the art for a PAR 38 lamp and lamp reflector unit that comprises a halogen lamp of suitable power greater than 68 W, for example 100 Watts coated with an infrared film to reflect the infrared energy produced by the halogen lamp back to the filament, making it more efficient; and/or that meets and preferably exceeds the minimum EPACT efficacy standards; and/or that exhibits a median life of at least about 3000 hours,
30 while giving light output greater than 90% from the original value at about 1750 hours; and/or that exhibits all of the foregoing characteristics or combinations thereof.

An object of the invention is to provide a new PAR 38 lamp and lamp reflector unit that comprises a halogen lamp of suitable power greater than 68 W, for example 100 Watts coated with an infrared film to reflect the infrared energy produced by the halogen lamp back to the filament, making it more efficient; and/or that meets and preferably exceeds the
5 minimum EPACT efficacy standards; and/or that exhibits a median life of at least about 3000 hours, while giving light output greater than 90% from the original value at about 1750 hours; and/or that exhibits all of the foregoing characteristics or combinations thereof.

These and other objects of the invention will be apparent from a description of the
10 invention which follows.

The objects of the invention may be accomplished through the provision of a PAR-38 lamp and lamp/reflector unit having the characteristics described above which comprises a reflector body (1) including a reflector portion (2) having a concave reflecting surface (3) with an optical axis (4) and, integral therewith, a hollow neck-shaped portion
15 (5) about the optical axis (4), an electric lamp (10) comprising:

- (a) a light-transmitting lamp vessel (11),
said lamp vessel comprising a quartz-glass wall (12) which encloses a cavity (13) of a predetermined, in general, spherical or elliptical shape with a geometric center (14),
said wall (12) being at least partly provided with an infrared-reflecting and visible
20 light-transmitting coating (15), and
said cavity (13) accommodating a substantially linear electric light source (16),
- (b) a metal foil (not shown) which is entirely embedded in the wall (12) and connected to the electric light source (16),
- (c) a first end portion (21) and a second end portion (22) which are arranged so as
25 to be opposite to each other and which both comprise a seal,
- (d) a respective current conductor (23; 24) connected to the embedded metal foil (17; 18) which issues from the lamp vessel (11) to the exterior, and is connected to metal foil through the seals,
- (e) a metal positioning member (40) in the neck which holds the lamp vessel and
30 through which the lamp seal is passed,
- (f) and a ceramic insert (42) beneath the mounting ring and through which the seal of the first end portion is passed, wherein,

the electric lamp (10) is arranged in the reflector body (1) in such a manner that the first end portion (21) is at least partly situated in the neck-shaped portion (5), the cavity (13) is situated within the reflecting portion (2), the electric light source (16) is predominantly situated on the optical axis (4), and the ceramic insert is effective to dissipate heat from the first end portion (21) during operation of the lamp.

U.S. Patent 6,404,112B1, issued June 11, 2002, titled "Electric Lamp/Reflector Unit" and assigned to the same assignee as in this application, relates to a way to adapt the dimensions of a double-ended halogen lamp and a reflector body so as to attain a satisfactory temperature balance. These principles may be employed in this invention as well and the disclosure of said patent is incorporated herein by reference. When embodied in the present invention, as described in said patent, the connection point (28) where the first end portion current conductor (23) is connected to the metal foil (17) of the first end portion (21) may be a distance d_c^I from the geometric center (14), the first end portion (21) will have a length l_{ep}^I measured from the geometric center (14), the connection point (27) where the second end portion current conductor (24) is connected to the metal foil (18) of the second end portion (22) will be a distance d_c^{II} from the geometric center (14), the second end portion (22) will have a length l_{ep}^{II} measured from the geometric center (14), and the ratios of the distances d_c^I ; d_c^{II} to the respective lengths l_{ep}^I ; l_{ep}^{II} is $d_c^I/l_{ep}^I > 0.75$ and $d_c^{II}/l_{ep}^{II} > 0.75$.

In accordance with the invention, an improvement in PAR-38 lamps, it has been found that the EPACT standards, the lamp efficiency and a long lamp life may be attained while lowering the press temperature to a safe operating temperature by practicing the invention parameters above described.

In preferred embodiments of the invention, one of the end portions of the electric lamp is arranged at least partly in the neck portion of the reflector body, it is achieved, viewed along the optical axis, to reduce the relative height of the electric lamp, if desired, with respect to the reflector body, which has a favorable influence on the ratio of the dimensions of the double-ended electric lamp with respect to the dimension of the reflector body of the known electric lamp/reflector unit. In the known electric lamp/reflector unit, a double-ended halogen lamp is bodily arranged in the reflector portion of the reflector body by means of so-called mounting legs. By securing, in accordance with the invention, the

first end portion of the electric lamp in the neck portion of the reflector body, a sturdy and reliable connection of the electric lamp with the reflector body is achieved. In addition, the positioning of the electric light source on the optical axis of the reflector portion is improved thereby, the electric light source preferably being positioned such that the
5 geometric center of the electric lamp is situated in the focus of the concave reflecting surface. The improved positionability results in a higher light output and a better light distribution of the electric lamp/reflector unit.

The inventors have recognized that in the known electric lamp/reflector unit, the so-called pinch temperature of the electric lamp increases during operation which adversely
10 affects, in particular, the service life of the electric lamp. The temperature of the pinch of a lamp is measured at the location of the connection point (generally formed by a welded joint) of the (external) current conductor and the metal foil embedded in the wall of the electric lamp. In general, a high pinch temperature enhances corrosion of the metal foil and/or the external current conductor. Corrosion leads to failure of the lamp as a result of
15 the current supply being interrupted. Other causes of failure include, for example, leakage of the lamp vessel or non-passive failure of the lamp. In the electric lamp in accordance with the invention, a ceramic insert inside of a electric lamp/reflector unit is effective to lower the pinch temperature and avoid thermal shock of the halogen burner. The halogen burner is placed through the ceramic insert and fit into the reflector wherein the ceramic
20 insert acts as a heat sink taking the heat off the press. The ceramic insert fits tight onto the inside part of the glass reflector and has an orifice in the center which the halogen burner passes through. This allows the heat to be conducted off the burner and out of the lamp more effectively and a reduction of the pinch temperature is obtained.

The safety of the electric lamp/reflector unit is enhanced if the emission window of
25 the reflector body is closed by means of a lens (31). In this manner, it can be precluded that inflammable objects come into contact with hot parts of the lamp. In addition, such a lens can limit the risks as a result of a non-passive failure of the lamp vessel by containing within the outer envelope the energy released by the non-passive failure. The lens may be fixed to the reflector body by means of an adhesive 43, for example silicone paste.
30 Alternatively, the lens can be secured mechanically, using, for example, a metal ring which is rolled over the reflector body. A clamping ring or a number of clamps may alternatively be used. The lens may be flat or curved.

In a favorable modification, the reflecting portion has a substantially cylindrical end portion near the lens. By virtue thereof, the volume within the reflecting portion can be larger so as to obtain a lower overall temperature, if so desired, without the increase in volume leading to an increase in diameter of the unit. It is alternatively possible to provide
5 the reflector body at the outside with a profiled, for example rippled, surface. As a result, the surface area is increased, enabling a greater heat emission.

The electric lamp may be an incandescent body, for example in a halogen-containing inert gas, or an electrode-pair in an ionizable gas. Particularly if the cavity of the lamp vessel is in the shape of an ellipse provided with an infrared-reflecting and visible
10 light-transmitting coating, and if a spiral-shaped linear incandescent body is arranged in the cavity, the heat in the form of infrared light generated by the incandescent body is very effectively reflected back to the incandescent body, as a result of which the current demanded from the power source is reduced, so the lamp becomes more efficient.

The ceramic insert may be formed of materials known in the art, for example, it
15 may be made of steatite, aluminum oxide, aluminum nitride, or the like. Particularly preferred for use herein is a material available commercially as L3 Steatite which comprises SiO_2 -MgO-BaO.

A particularly favorable embodiment of the electric lamp/reflector unit in accordance with the invention is characterized in that an internal current conductor which
20 connects the electric light source with the metal foil is bent such that the electric light source is substantially situated on the optical axis. The better the electric light source is centered with respect to the spherical or elliptic shape of the cavity, the more effective the action of the infrared-reflecting coating and the higher the efficiency of the electric lamp is. In addition, the better the electric light source is centered with respect to the geometric
25 center, which is preferably situated on the optical axis of the reflector body, the better the light distribution is as a result of the reflection from the concave reflecting surface of the reflector body.

In order to further reduce the temperature of the end portions, said end portions may be sandblasted during the manufacture of the electric lamp. This has the advantage
30 that the end portions are not covered with an infrared-reflecting coating, which leads to a reduction of the temperature of the end portions and hence of the pinch temperature. An additional advantage of sandblasting resides in that the surface of the end portions is

roughened, so that a larger heat-radiating surface is obtained and hence overall internal light reflection in the end portions as a result of the coating is reduced.

In a preferred embodiment of the electric lamp/reflector unit in accordance with the invention, the metal foil and the first and the second current conductor may be at least
5 partly provided with a protective coating at the location of the connection point. This protective coating reduces the risk of corrosion of the metal foil and the current conductor at the location of the connection point. As a result of said corrosion protection, an acceptable service life of the electric lamp in the electric lamp/reflector unit may also be extended while the risk of explosion of the lamp is negligible. Preferably, the protective
10 coating contains chromium. It has been found that chromium can be effectively used as a protective coating on electric conductors of molybdenum and tungsten in quartz glass, and forms low-melting products with these materials. A chromium protective layer having a layer thickness in the range from 0.5 to 2 μm is particularly favorable. The layer thickness of the coating is a parameter which, among other things, determines the degree of
15 corrosion protection.

In a particularly favorable embodiment, the current conductor is led from the second end portion via an electroconductive connection to the neck-shaped portion of the reflector body. Preferably, the connection is at least partly made from nickel. Nickel is a stable material having a good coefficient of heat conduction and it can also be used as a
20 contact member of the electric lamp/reflector unit. A material which can be alternatively used for the manufacture of said connection is stainless steel.

These and other aspects of the invention will be apparent from and elucidated with reference to the embodiments described hereinafter.

The invention will be better understood with reference to the details of specific
25 embodiments that follow.

FIG. 1 is a cross-sectional view of an electric lamp/reflector unit in accordance with the invention;

FIG. 2 is a view of a ceramic insert of the invention; and

FIG. 3 is a perspective of the halogen burner with connectors, metal positioning
30 ring, ceramic insert, and reflector body of the invention (unassembled).

The Figures are purely diagrammatic and not drawn to scale. Particularly for clarity some dimensions are exaggerated strongly. In the Figures, like reference numerals refer to like parts whenever possible.

FIG. 1 shows an electric lamp/reflector unit in accordance with the invention in cross-section. As illustrated, the electric lamp/reflector unit 50 comprises a shaped reflector body 1 having a reflector portion 2 with a concave reflecting surface 3 and an optical axis 4. A hollow, neck-shaped portion 5 situated around the optical axis 4 is integral with the reflector portion 2. In the example shown in FIG. 1, the emission window of the reflector body 1 is closed by means of a curved lens 31. In an alternative embodiment, said lens 31 is flat. The embodiment of the electric lamp/reflector unit shown in FIG. 1 is the reflector body 1 of the PAR 38 type.

The electric lamp/reflector unit further comprises an electric lamp 10 including a gastight light-transmitting lamp vessel 11 having a quartz glass wall 12 enclosing a cavity 13 of a predetermined, generally, spherical or elliptic shape with a geometric center 14. In the example shown in FIG. 1, the shape of the cavity 13 is substantially elliptical. The cavity 13 of the lamp vessel 11 accommodates a substantially linear electric light source 16, for example an incandescent body in the form of a spirally wound tungsten wire. At the location where the wall 12 of the lamp vessel 11 is elliptical in shape, the wall 12 of the lamp vessel 11 is provided with an infrared-reflecting and visible light-transmitting coating 15. The infrared radiation generated by the incandescent body is reflected back to the incandescent body by this coating 15, causing the efficiency of the electric lamp 10 to be increased substantially. The visible light is passed by the coating 15.

The infrared-reflecting and visible light-transmitting coatings 15 are known per se. Such (>40 layers), the thicknesses of the individual coatings generally comprise a multilayer interference filter optical layers being calculated by means of computer programs known to those skilled in the art. Such optical interference films are generally applied by means of coating techniques which are known per se, such as vapor deposition, dip coating, (reactive) sputtering and chemical vapor deposition.

In FIG. 1, the geometric center 14 of the electric lamp/reflector unit is situated at the intersection of the optical axis 4 and a further axis 4'; 4" at right angles to the optical axis 4, in the center of the lamp vessel 11. In the wall 12 of the electric lamp 10, metal foils (not shown) may be embedded on both sides. These metal foils are connected to the

electric light source 16. The electric lamp 10 further comprises a first end portion 21 and a second end portion 22 which are both provided with a seal. The second end portion 22 is arranged so as to be opposite to the first end portion 21. An electric lamp 10 comprising a combination of two end portions 21; 22 between which there is a cavity is commonly referred to as a double-ended electric lamp, in the example shown in FIGs. 1 and 3, a so-called double-ended halogen lamp. Through the end portions 21; 22, current conductors 23; 24 which are connected to the embedded metal foil issue from the lamp vessel 11 to the exterior.

The electric lamp 10 is arranged in the reflector body 1, the first end portion 21 being situated at least partly in the neck-shaped portion 5, the cavity 13 being situated within the reflecting portion 2, and the electric light source 16 being situated substantially on the optical axis 4.

FIG. 1 further shows that the current conductor 24 projects from the second end portion 22 and is guided via an electroconductive connection 34, to the neck-shaped portion 5 of the reflector body 1. A particularly favorable connection 34 is made from nickel. The current conductor 23 is correspondingly connected to an electroconductive connection 33. These parts are passed through the metal positioning ring 40 and through the ceramic insert 42 with the connectors 34 and 33 passing through holes 44 of the ceramic insert. Both connections 33; 34 issue from the ceramic insert to the exterior to eyelets 28 which complete the connection to fuse wire 29 and nickel wire 27 which are welded, soldered or otherwise attached to the skirted base 30.

Two types of 100 watt/120 volt double-ended halogen lamp vessels were evaluated for the manufacturing of a PAR 38 electric lamp/reflector unit of this invention. Lot A lamp vessels were manufactured with filling gas with 5.5 Bars of pressure, and Lot B were manufactured with filling gas with 6.5 Bars of pressure. A sample of 20 capsules of each lot was assembled into PAR 38 lamps and they were lifetime tested. The results are reported in Table 1.

Table #1: Lifetime lamps manufactured without ceramic insert.

TEST NUMBER	ACTUAL LIFETIME	LAMP SAMPLE	NUMBER OF FAILURES	FAILURE RATE	FAILURE MODE
2ET31 Lamps made without ceramic insert Capsules from lot A.	1705 hours	20	20	5% at 837 hours.	1x split pinch.
				35% at 1059 hours.	3x Split pinch, blackening, broken coil.
				5% at 1195 hours.	3x Split pinch, broken coil.
				65% at 1206 hours.	2x Split pinch, broken coil.
				90% at 1463 hours.	1x Split pinch, broken coil, blackening
				95% at 1569 hours.	1x Split pinch, 1x split pinch, blackening.
2ET25 Lamps made without ceramic insert Capsules from lot B.	1596 hours	20	20	100% at 1705 hours.	1x Split pinch.
				30% at 671 hours.	3x Split pinch, blackening, broken coil.
				55% at 839 hours.	1x Split pinch, broken coil.
				60% at 999 hours.	4x Split pinch, broken coil, blackening.
				80% at 1181 hours.	1x Split pinch, broken coil, blackening.
				90% at 1343 hours.	4x Split pinch, broken coil.
				95% at 1443 hours.	1x Split pinch
				100% at 1596 hours.	1x Split pinch, blackening.
					1x Split pinch, blackening, broken coil.
					1x Split pinch blackening, broken coil.

In this test the results in lifetime were very poor having a median life around 900 to 1300 hours. In addition, it was also observed that the common failure mode was split pinch on the capsules. Moreover, before the pinch of the lamp vessel or capsule split, the high working temperature caused the coating applied to the body of the capsule to degrade. This degradation manifested itself by turning the capsule black, thus reducing the light output.

A thermocouple was attached in the pinch area of the burner and it was assembled into a lamp. This lamp was lighted in fixtures during one hour and the temperature was registered. This procedure was performed on five lamps to choose the maximum temperature of the five lamps.

Because of the high temperature found in this test, five lamps were assembled with a ceramic insert to investigate if this ceramic could reduce the pinch temperature. The results are reported in Table 2.

Table #2: Capsule pinch temperature.

CAPSULE DESCRIPTION	PAR 38 LAMP		TEMPERATURE
	Ceramic	No ceramic	DIFFERENCE
100W / 120V	359 °C	445 °C	86 °C
100W / 130V	342 °C	407 °C	65 °C
*92W / 120V	318 °C	378 °C	60 °C

Note: * Lamps with 100 watts / 130 volts capsule tested @ 120 volts.

From these results it was observed that the ceramic insert reduced the capsule working temperature.

Another sample of 20 capsules of each lot (A and B) was assembled into PAR 38 lamps for lifetime evaluation. This time the ceramic insert was added to the lamp assembly. The results are reported in Table 3.

Table #3: Lifetime performed to lamps manufactured with ceramic insert.

TEST NUMBER	ACTUAL LIFETIME	LAMP SAMPLE	NUMBER OF FAILURES	FAILURE RATE	FAILURE MODE
2ET42 Lamps made with ceramic insert Capsules from lot A.	>1600 hours	20	0	0	No failures have occurred yet and the test is on going.
2ET35 Lamps made with ceramic insert Capsules from lot B.	>2700 hours	20	0	0	No failures have occurred yet and the test is on going.

The above lifetime tests were extended. No failures have occurred after 3000 hours and the tests are still ongoing.

The lamp vessel 11 of the double-ended halogen lamps in accordance with the invention preferably has an elliptical cavity 13. The outer surface of the cavity 13 is provided with an infrared-reflecting and visible light-transmitting coating 14. The coating 14 preferably comprises a 47-layer $\text{Nb}_2\text{O}_5/\text{SiO}_2$ infrared-reflecting interference filter which is provided by means of reactive sputtering.

It will be obvious that, within the scope of the invention, many variations are possible to those skilled in the art. For example, the invention is not limited to an electric lamp/reflector unit comprising an electric lamp including an incandescent body; the electric lamp may alternatively comprise an electrode pair in an ionisable gas. In addition, the infrared-reflecting and visible light-transmitting coating provided on the electric lamp may be omitted.

The scope of protection of the invention is not limited to the above-described examples. The invention is embodied in each novel characteristic and each combination of characteristics. Reference numerals in the claims do not limit the scope of protection thereof. The use of the term "comprising" does not exclude the presence of elements other than those mentioned in the claims. The use of the word "a" or "an" in front of an element does not exclude the presence of a plurality of such elements.

CLAIMS:

1. An electric lamp/reflector unit, capable of operating at a power greater than 68 W, comprising:
 - a reflector body (1) including a reflector portion (2) having a concave reflecting surface (3) with an optical axis (4) and, integral therewith, a hollow neck-shaped portion (5) about the optical axis (4),
 - an electric lamp (10) comprising:
 - (a) a light-transmitting lamp vessel (11),
 - said lamp vessel comprising a quartz-glass wall (12) which encloses a cavity (13) of a predetermined, in general, spherical or elliptical shape with a geometric center (14), said wall (12) being at least partly provided with an infrared-reflecting and visible light-transmitting coating (15), and
 - said cavity (13) accommodating a substantially linear electric light source (16),
 - (b) a metal foil (not shown) which is entirely embedded in the wall (12) and connected to the electric light source (16),
 - (c) a first end portion (21) and a second end portion (22) which are arranged so as to be opposite to each other and which both comprise a seal,
 - (d) a respective current conductor (23; 24) connected to the embedded metal foil (17; 18) which issues from the lamp vessel (11) to the exterior, and is connected to metal foil through the seals,
 - (e) a metal positioning member (40) in the neck which holds the lamp vessel and through which the lamp seal is passed,
 - (f) and a ceramic insert (42) beneath the mounting ring and through which the seal of the first end portion is passed, wherein,
 - the electric lamp (10) is arranged in the reflector body (1) in such a manner that the first end portion (21) is at least partly situated in the neck-shaped portion (5),
 - the cavity (13) is situated within the reflecting portion (2), the electric light source (16) is predominantly situated on the optical axis (4), and the ceramic insert is effective to dissipate heat from the first end portion (21) during operation of the lamp.
2. An electric lamp/reflector unit as claimed in claim 1, wherein the electric lamp meets at least the minimum EPACT efficacy standards.

3. An electric lamp/reflector unit as claimed in claim 1, wherein the electric lamp exhibits a median life of at least about 3000 hours, while giving light output greater than 90% from the original value at about 1750 hours.
4. An electric lamp/reflector unit as claimed in claim 1, wherein the connection point (28) where the first end portion current conductor (23) is connected to the metal foil (17) of the first end portion (21) is a distance d_c^I from the geometric center (14), the first end portion (21) has a length l_{ep}^I measured from the geometric center (14), the connection point (27) where the second end portion current conductor (24) is connected to the metal foil (18) of the second end portion (22) is a distance d_c^{II} from the geometric center (14), the second end portion (22) has a length l_{ep}^{II} measured from the geometric center (14), and the ratios of the distances d_c^I ; d_c^{II} to the respective lengths l_{ep}^I ; l_{ep}^{II} is $d_c^I/l_{ep}^I > 0.75$ and $d_c^{II}/l_{ep}^{II} > 0.75$.
5. An electric lamp/reflector unit as claimed in claim 1, wherein the ceramic insert fits tight onto the inside part of the glass reflector and has an orifice in the center which the lamp vessel passes through.
6. An electric lamp/reflector unit as claimed in claim 1, wherein the reflector body is closed by means of a lens (31).
7. An electric lamp/reflector unit as claimed in claim 6, wherein the cavity of the lamp vessel is in the shape of an ellipse and is provided with an infrared-reflecting and visible light-transmitting coating.
8. An electric lamp/reflector unit as claimed in claim 7, wherein a spiral-shaped linear incandescent body is arranged in the cavity and the heat in the form of infrared light generated by the incandescent body is reflected back to the incandescent body.
9. An electric lamp/reflector unit as claimed in claim 1, wherein the current conductor (24) projects from the second end portion (22) and is guided via an electroconductive connection (34), to the neck-shaped portion (5) of the reflector body (1) and the current conductor (23) is correspondingly connected to an electroconductive connection (33).
10. An electric lamp/reflector unit as claimed in claim 9, wherein the electroconductive connection (34) is at least partly made from a nickel or stainless steel contact member.
11. An electric lamp/reflector unit as claimed in claim 1, wherein the coating (15) comprises a multilayer interference filter.
12. An electric lamp/reflector unit as claimed in claim 11, wherein said coating is a 47-layer Nb_2O_5/SiO_2 infrared-reflecting interference filter.

13. An electric lamp/reflector unit as claimed in claim 9, wherein : the lamp vessel with connectors pass through the metal positioning ring (40) and through the ceramic insert (42) with the connectors (34) and (33) passing through holes (44) of the ceramic insert.

14. An electric lamp/reflector unit as claimed in claim 13, wherein said connections (33), (34) issue from the ceramic insert to the exterior to eyelets (28).

15. An electric lamp/reflector unit as claimed in claim 14, wherein said eyelets complete the connection to fuse wire (29) and nickel wire (27) which are attached to a skirted base (30).

16. An electric lamp 10 for use in an electric lamp/reflector unit as claimed in claim 1.

17. An electric lamp 10 for use in a PAR 38 lamp and lamp reflector unit that comprises a halogen lamp as claimed in claim 1 of suitable power greater than 68 W coated with an infrared film to reflect the infrared energy produced by the halogen lamp back to the filament, making it more efficient; and/or that meets and preferably exceeds the minimum EPACT efficacy standards; and/or that exhibits a median life of at least about 3000 hours, while giving light output greater than 90% from the original value at about 1750 hours; and/or that exhibits all of the foregoing characteristics or combinations thereof.

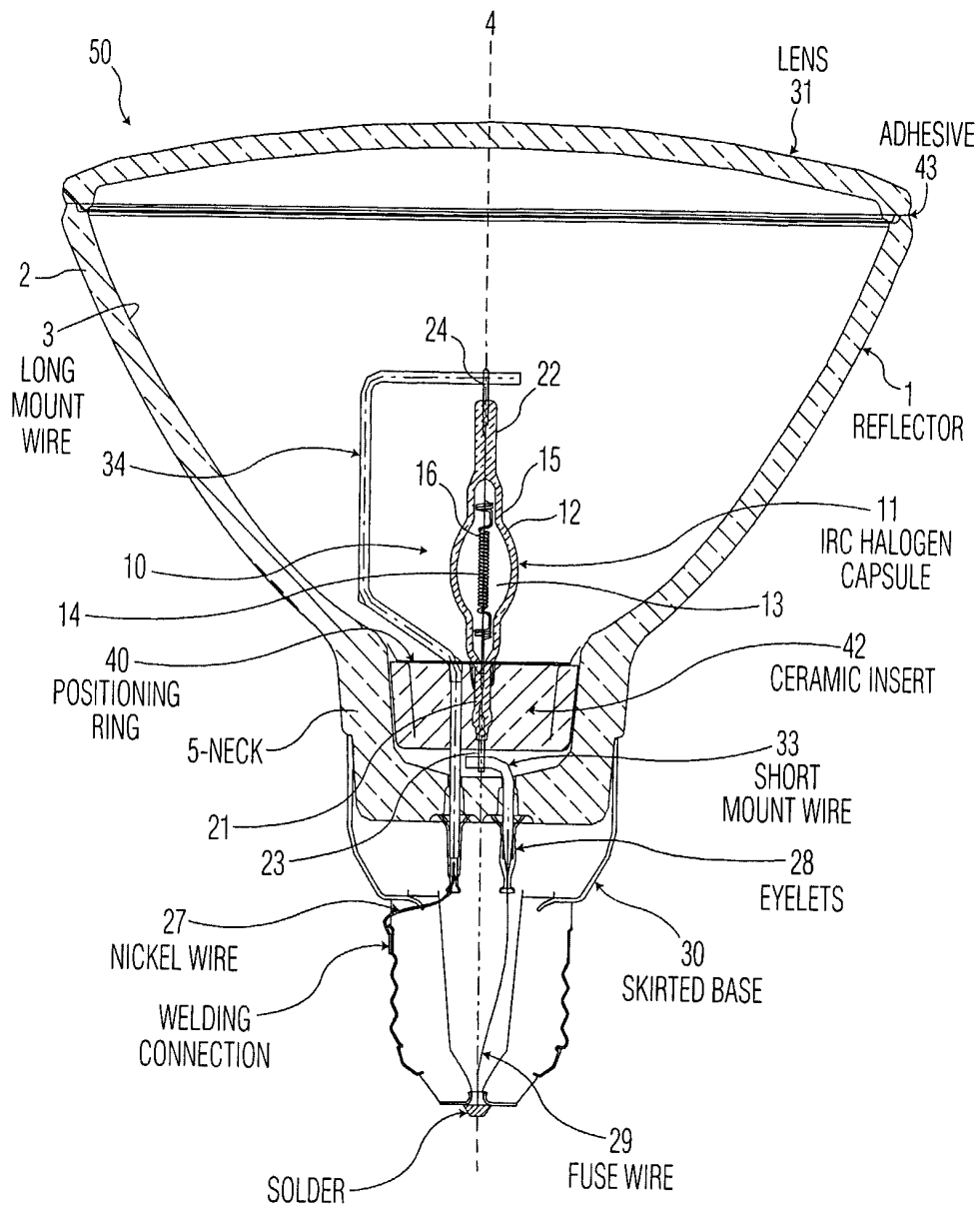

FIG. 1

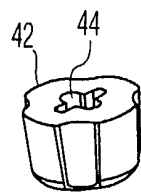

FIG. 2

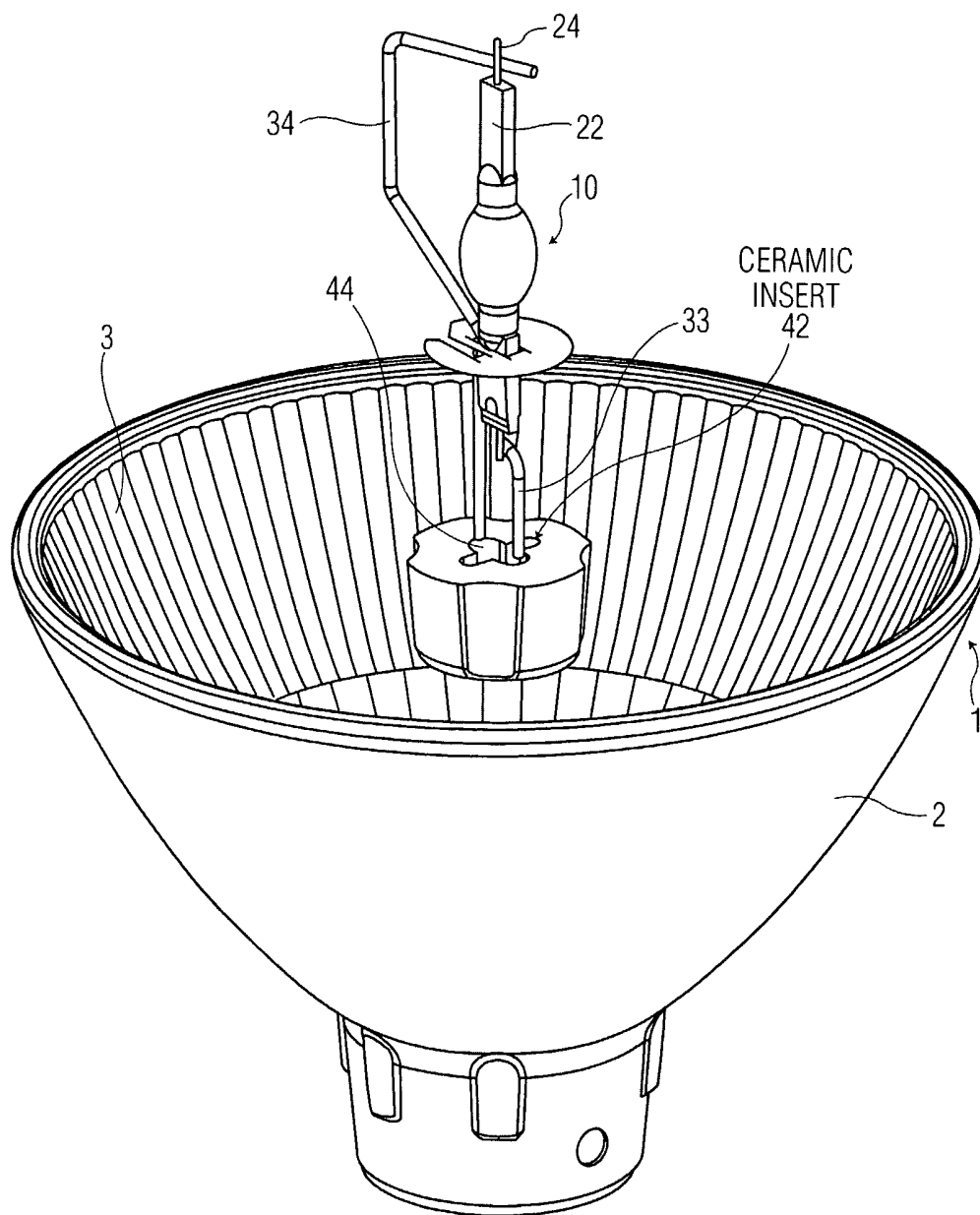

FIG. 3

INTERNATIONAL SEARCH REPORT

International Classification No
PCT/IB 03/05118

A. CLASSIFICATION OF SUBJECT MATTER

IPC 7 H01K1/24 H01K1/34 H01K1/58 H01K1/32 H01J61/34
H01J61/52 F21V29/00

According to International Patent Classification (IPC) or to both national classification and IPC

B. FIELDS SEARCHED

Minimum documentation searched (classification system followed by classification symbols)
IPC 7 H01K H01J F21V

Documentation searched other than minimum documentation to the extent that such documents are included in the fields searched

Electronic data base consulted during the international search (name of data base and, where practical, search terms used)

EPO-Internal, WPI Data, PAJ

C. DOCUMENTS CONSIDERED TO BE RELEVANT

Category °	Citation of document, with indication, where appropriate, of the relevant passages	Relevant to claim No.
X	US 5 646 473 A (EGGINK HENDRIK J ET AL) 8 July 1997 (1997-07-08) cited in the application	1-3,5,6, 16
Y	the whole document column 3, line 14 - column 4, line 43	4,7-15
Y	WO 00/75957 A (PHILIPS CORP INTELLECTUAL PTY ; KONINKL PHILIPS ELECTRONICS NV (NL)) 14 December 2000 (2000-12-14) cited in the application	4,7-15
X	abstract page 7, line 17 - page 11, line 19; figures 1a,1b,2a	16
	----- -/--	

Further documents are listed in the continuation of box C.

Patent family members are listed in annex.

° Special categories of cited documents :

- *A* document defining the general state of the art which is not considered to be of particular relevance
- *E* earlier document but published on or after the international filing date
- *L* document which may throw doubts on priority claim(s) or which is cited to establish the publication date of another citation or other special reason (as specified)
- *O* document referring to an oral disclosure, use, exhibition or other means
- *P* document published prior to the international filing date but later than the priority date claimed

- *T* later document published after the international filing date or priority date and not in conflict with the application but cited to understand the principle or theory underlying the invention
- *X* document of particular relevance; the claimed invention cannot be considered novel or cannot be considered to involve an inventive step when the document is taken alone
- *Y* document of particular relevance; the claimed invention cannot be considered to involve an inventive step when the document is combined with one or more other such documents, such combination being obvious to a person skilled in the art.
- *&* document member of the same patent family

Date of the actual completion of the international search

23 February 2004

Date of mailing of the international search report

01/03/2004

Name and mailing address of the ISA

European Patent Office, P.B. 5818 Patentlaan 2
NL - 2280 HV Rijswijk
Tel. (+31-70) 340-2040, Tx. 31 651 epo nl,
Fax: (+31-70) 340-3016

Authorized officer

Lang, T

INTERNATIONAL SEARCH REPORT

International	Application No
PCT/IB 03/05118	

C.(Continuation) DOCUMENTS CONSIDERED TO BE RELEVANT		
Category °	Citation of document, with indication, where appropriate, of the relevant passages	Relevant to claim No.
A	<p>US 6 382 816 B1 (ISRAEL RAJASINGH SCHWARTZ ET AL) 7 May 2002 (2002-05-07) abstract column 1, line 33 - line 46 column 4, line 50 - column 5, line 8; figure 5</p> <p style="text-align: center;">-----</p>	1-3
A	<p>WO 96/08035 A (PHILIPS ELECTRONICS NV ; PHILIPS NORDEN AB (SE)) 14 March 1996 (1996-03-14) abstract page 1, line 10 - page 3, line 11 page 5, line 24 - page 6, line 8; figure 2</p> <p style="text-align: center;">-----</p>	1-3
A	<p>WO 97/15945 A (PHILIPS ELECTRONICS NV ; PHILIPS NORDEN AB (SE)) 1 May 1997 (1997-05-01) abstract page 1, line 27 - page 2, line 32 page 4, line 10 - page 5, line 31; figure 1</p> <p style="text-align: center;">-----</p>	1-3

Box I Observations where certain claims were found unsearchable (Continuation of item 1 of first sheet)

This International Search Report has not been established in respect of certain claims under Article 17(2)(a) for the following reasons:

1. Claims Nos.:
because they relate to subject matter not required to be searched by this Authority, namely:

2. Claims Nos.: 17
because they relate to parts of the International Application that do not comply with the prescribed requirements to such an extent that no meaningful International Search can be carried out, specifically:
see FURTHER INFORMATION sheet PCT/ISA/210

3. Claims Nos.:
because they are dependent claims and are not drafted in accordance with the second and third sentences of Rule 6.4(a).

Box II Observations where unity of invention is lacking (Continuation of item 2 of first sheet)

This International Searching Authority found multiple inventions in this international application, as follows:

1. As all required additional search fees were timely paid by the applicant, this International Search Report covers all searchable claims.

2. As all searchable claims could be searched without effort justifying an additional fee, this Authority did not invite payment of any additional fee.

3. As only some of the required additional search fees were timely paid by the applicant, this International Search Report covers only those claims for which fees were paid, specifically claims Nos.:

4. No required additional search fees were timely paid by the applicant. Consequently, this International Search Report is restricted to the invention first mentioned in the claims; it is covered by claims Nos.:

Remark on Protest

- The additional search fees were accompanied by the applicant's protest.
- No protest accompanied the payment of additional search fees.

FURTHER INFORMATION CONTINUED FROM PCT/ISA/ 210

Continuation of Box I.2

Claims Nos.: 17

Present claim 17 relates to an extremely large number of possible apparatus. The closing phrase of this claim "or that exhibits ... foregoing characteristics or combinations thereof", as well as the three possible levels of permutations "and/or" in this claim, implies so many possible permutations, namely any combination of any two or more features listed in this claim, that a lack of clarity and conciseness within the meaning of Article 6 PCT arises to such an extent as to render a meaningful search of the claim impossible.

Moreover, the wording of claim 17 is utterly unclear in itself: "An electric lamp ... AND a lamp reflector unit that comprises a halogen lamp" literally implies an aggregation of TWO lamps (an electric lamp and a halogen lamp, the latter in a lamp/reflector unit) which is not supported by the description, and appears not to be what is intended. If, however, only one of these items is intended to be claimed, it is unclear which. Further, the meaning of "a halogen lamp as claimed in claim 1" is unclear since claim 1 does not claim a halogen lamp, but an electric lamp/reflector unit. Already from this, a lack of clarity arises to such an extent as to render a meaningful search of the claim impossible.

Consequently, the search has been carried out for those parts of the application which do appear to be clear (and concise); as far as the features of claim 17 appear to be concerned this is claims 1-3.

The applicant's attention is drawn to the fact that claims relating to inventions in respect of which no international search report has been established need not be the subject of an international preliminary examination (Rule 66.1(e) PCT). The applicant is advised that the EPO policy when acting as an International Preliminary Examining Authority is normally not to carry out a preliminary examination on matter which has not been searched. This is the case irrespective of whether or not the claims are amended following receipt of the search report or during any Chapter II procedure. If the application proceeds into the regional phase before the EPO, the applicant is reminded that a search may be carried out during examination before the EPO (see EPO Guideline C-VI, 8.5), should the problems which led to the Article 17(2) declaration be overcome.

INTERNATIONAL SEARCH REPORT

Information on patent family members

International

Application No

PCT/IB 03/05118

Patent document cited in search report		Publication date		Patent family member(s)	Publication date
US 5646473	A	08-07-1997	CN	1136855 A , B	27-11-1996
			DE	69516425 D1	25-05-2000
			DE	69516425 T2	19-10-2000
			EP	0801806 A1	22-10-1997
			WO	9607193 A1	07-03-1996

WO 0075957	A	14-12-2000	CN	1316097 T	03-10-2001
			WO	0075957 A1	14-12-2000
			EP	1103064 A1	30-05-2001
			JP	2003501793 T	14-01-2003
			US	6404112 B1	11-06-2002

US 6382816	B1	07-05-2002	US	2002126487 A1	12-09-2002

WO 9608035	A	14-03-1996	US	5493170 A	20-02-1996
			CN	1137328 A	04-12-1996
			DE	69505230 D1	12-11-1998
			EP	0728366 A1	28-08-1996
			WO	9608035 A1	14-03-1996
			JP	9505442 T	27-05-1997
			US	5789847 A	04-08-1998

WO 9715945	A	01-05-1997	US	5789847 A	04-08-1998
			CN	1174631 A	25-02-1998
			EP	0799492 A2	08-10-1997
			WO	9715945 A2	01-05-1997
			JP	10512095 T	17-11-1998
