

(12) INTERNATIONAL APPLICATION PUBLISHED UNDER THE PATENT COOPERATION TREATY (PCT)

(19) World Intellectual Property Organization
International Bureau



(43) International Publication Date
14 December 2000 (14.12.2000)

PCT

(10) International Publication Number
WO 00/75057 A1

- (51) International Patent Classification⁷: B65G 57/32, 47/24
- (21) International Application Number: PCT/US00/14310
- (22) International Filing Date: 25 May 2000 (25.05.2000)
- (25) Filing Language: English
- (26) Publication Language: English
- (30) Priority Data:
09/326,682 7 June 1999 (07.06.1999) US
- (71) Applicant: RECOT, INC. [US/US]; Suite 460, 5000 Hop-
yard Road, Pleasanton, CA 94588 (US).
- (72) Inventors: BIERSCHENK, Patrick, J.; 4325 Hanover,
Dallas, TX 75225 (US). BRAITHWAITE, Steven, D.; 513
Oakwook Drive, Allen, TX 75013 (US). MICHELS, John,
J.; 3004 Harvest Knoll, Highland Village, TX 75077 (US).
- (74) Agents: NEWLAND, Bart, G. et al.; Rothwell, Figg,
Ernst & Manbeck, Suite 701 East, 555 13th Street N.W.,
Columbia Square, Washington, DC 20004 (US).
- (81) Designated States (*national*): AE, AG, AL, AM, AT, AU,
AZ, BA, BB, BG, BR, BY, CA, CH, CN, CR, CU, CZ, DE,
DK, DM, DZ, EE, ES, FI, GB, GD, GE, GH, GM, HR, HU,
ID, IL, IN, IS, JP, KE, KG, KP, KR, KZ, LC, LK, LR, LS,
LT, LU, LV, MA, MD, MG, MK, MN, MW, MX, MZ, NO,
NZ, PL, PT, RO, RU, SD, SE, SG, SI, SK, SL, TJ, TM, TR,
TT, TZ, UA, UG, UZ, VN, YU, ZA, ZW.
- (84) Designated States (*regional*): ARIPO patent (GH, GM,
KE, LS, MW, MZ, SD, SL, SZ, TZ, UG, ZW), Eurasian
patent (AM, AZ, BY, KG, KZ, MD, RU, TJ, TM), European
patent (AT, BE, CH, CY, DE, DK, ES, FI, FR, GB, GR, IE,
IT, LU, MC, NL, PT, SE), OAPI patent (BF, BJ, CF, CG,
CI, CM, GA, GN, GW, ML, MR, NE, SN, TD, TG).
- Published:**
— With international search report.
- For two-letter codes and other abbreviations, refer to the "Guidance Notes on Codes and Abbreviations" appearing at the beginning of each regular issue of the PCT Gazette.*

(54) Title: METHOD AND APPARATUS FOR STACKING TORTILLA CHIPS

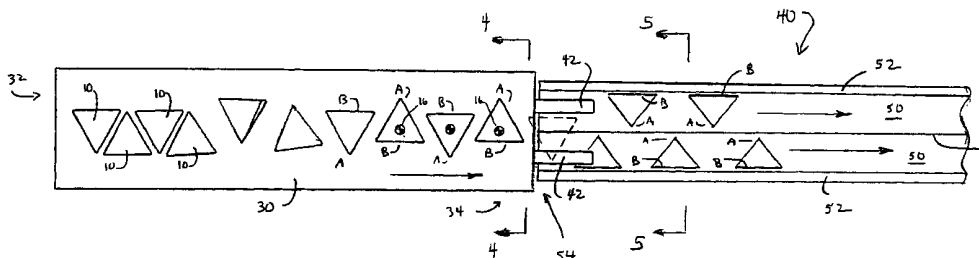

(57) Abstract: A method and apparatus for stacking curved, triangular snack food chips (10), e.g., tortilla chips (10), for packaging in a sleeve-type container. The chips (10) are fed into a first, U-shaped vibratory chute (30), which automatically causes the apex corners (A) of the chips (10) to extend beyond the opposing base edges (B) of adjacent chips (10) and which automatically orients the chips (10) such that lines (20) about which they are curved are oriented parallel to the longitudinal direction (21) of the U-shaped chute (30). The chips (10) are then fed into a W-shaped chute (40), with the chips (10) facing in opposite directions falling automatically into opposite troughs (44, 46) of the W-shaped chute (40). The chips (10) are then automatically reoriented by 120° such that their upturned apex corners point (A) in the direction of travel, and the chips (10) are stacked automatically as they slide up along one another in a shingled manner.

WO 00/75057 A1

METHOD AND APPARATUS FOR STACKING TORTILLA CHIPS**FIELD OF THE INVENTION**

5 The present invention relates generally to a method and apparatus for processing snack food chips. More particularly, the invention relates to a method and apparatus for stacking curved tortilla chips in a uniform stack which then can be packaged neatly and compactly, e.g., in a cylindrical can or
10 other sleeve-type container.

BACKGROUND OF THE INVENTION

Tortilla chips are one of the more popular types of snack food products and have come to be associated with having a
15 triangular shape. Additionally, snack food chips which are used for dipping, e.g., potato chips, tortilla chips, or corn chips, preferably are curved to enhance the scooping ability of the chip as well as to add strength to the chip.

With respect to packaging, a stacked arrangement of snack
20 food chips has been found to be popular. The typical triangular shape of a tortilla chip, however -- particularly a curved tortilla chip -- previously has prevented tortilla chips from being packaged in a stacked arrangement in an efficient, automatic process.

25

SUMMARY OF THE INVENTION

The present invention provides a method and apparatus for automatically arranging curved, triangular snack food chips

such as tortilla chips in a neat, compact, stacked arrangement which is suitable for packaging the chips in a cylindrical can or other sleeve-type package. According to the invention, the chips are transported along a vibrating U-shaped chute, oriented in an alternating arrangement. The vibrating U-shaped chute automatically ensures both proper orientation and positioning of the chips in that the chips slide laterally such that their centers of gravity are at the bottom of the chute and such that base edges of the triangular chips are oriented parallel to the longitudinal axis of the U-shaped chute. The chips then fall into a W-shaped vibrating chute, with the chips originally having one orientation automatically being caused to fall into the trough constituting one half of the W-shaped chute and the chips having the opposite orientation automatically being caused to fall into the other trough constituting the other half of the W-shaped chute.

The chips then travel along the W-shaped chute by sliding along their base edges, i.e., with their opposite, upturned apices pointing perpendicular to the direction of travel of the chips. The tortilla chips are then caused to rotate by 120° such that the upturned apices "lead" as the chips continue to progress. This configuration permits the chips to slide into nested, stacked relationship automatically, in which arrangement the chips can be packaged easily in a stacked configuration.

Thus, in a first aspect, the invention features a method of stacking curved, generally triangular tortilla chips for subsequent packaging, e.g., in a sleeve-type package. The method entails transporting a succession of the chips along a direction of travel, and while transporting the chips, causing them to be oriented such that their apex corners point in the direction of travel. The chips are then caused to become stacked automatically by virtue of the apex corner of one chip sliding up and over the base edge of the preceding chip in the succession such that they come into a stacked, nested arrangement automatically.

In preferred embodiments, the chips are oriented properly by sliding down a J-slide from one conveyor to another. Alternatively, the chips can be allowed to tumble over the end of the first conveyor onto the second conveyor.

In another aspect, the invention features a method of segregating the chips into separate lines or successions of chips based on the direction in which the chips point (as indicated by their upturned, apex corners). The method entails transporting the chips in a given direction of travel and causing the chips to be oriented such that the line about which each is curved is substantially parallel to the direction of travel. The chips are also caused to move laterally, relative to the direction of travel, such that their centers of gravity become generally aligned. (This may be done simultaneously with the step of causing the chips to

be oriented such that their lines of curvature are substantially parallel.) At this point, the straight base edges of the chips pointing in one direction will all be aligned, and the straight base edges of the chips pointing in the opposite direction will all be aligned, and the apex corners of the chips pointing in one direction will extend laterally beyond the base edges of the chips facing in the opposite direction and vice-versa. The chips are then segregated into two separate conveyor troughs by being tripped or partially flipped by means of their apex corners into the troughs, with the chips pointing in one direction going to one conveyor trough and the chips pointing in the other direction going to the other conveyor trough.

In preferred embodiments, the chips are both oriented and caused to move laterally simultaneously by transporting them along the bottom of a vibrating U-shaped chute, the radius of curvature of which preferably matches the radius of curvature of the chips. Additionally, the conveyor troughs are provided by means of a W-shaped chute, and the chips are tripped or partially flipped into one side of the "W" or the other.

In combination, these two aspects provide a method of segregating and stacking curved, generally triangular chips such as tortilla chips.

In another aspect, the invention features an apparatus for segregating and stacking for subsequent packaging a succession of curved, generally triangular chips. The

apparatus features a first, vibratory, generally U-shaped conveyor chute which feeds into a second, generally W-shaped conveyor chute. The W-shaped conveyor chute has means for rotating the chips by about 120°, and the apparatus includes two accumulator conveyors which receive chips from the W-shaped conveyor chute and which automatically accumulate and stack the chips in a nested, stacked arrangement.

In preferred embodiments, the first, U-shaped conveyor chute includes a pair of fingers extending from its downstream end, and the fingers are positioned above the two troughs of the second, W-shaped conveyor chute to trip or flip the chips into one trough or the other depending on the orientation of the chips. Additionally the W-shaped chute preferably is vibratory, as are the accumulator conveyors. The means for rotating the chips can be J-slides which transfer the chips from the troughs of the W-shaped chute to the accumulator conveyors or, alternatively, the chips can be allowed to tumble over the edge of the end of the W-shaped chute onto the accumulator conveyors.

By employing the various inventive concepts disclosed herein, it is possible to produce curved, triangular chips such as tortilla chips in alternating directions (which is the most efficient way to make tortilla chips) and then stack them automatically, conveniently, and reliably to be packaged in a popular sleeve-type container.

BRIEF DESCRIPTION OF THE DRAWINGS

The invention will now be described in greater detail in connection with the drawings, in which:

Figs. 1 and 2 are a plan view and a side view,
5 respectively, of a curved, triangular tortilla chip to be packaged using the method and apparatus of the invention;

Fig. 3 is a plan view of the upstream portion and part of the middle portion of the apparatus of the invention, and Fig. 3a is a plan view of the relevant portion of an alternative
10 configuration thereof;

Figs. 4 and 5 are section views of the apparatus shown in Fig. 3 taken along the lines 4-4 and 5-5, respectively;

Fig. 6 is a plan view of the downstream end of the middle portion of the apparatus of the invention where it joins the
15 upstream end of the downstream-most portion of the apparatus of the invention;

Figs. 7 and 8 are a side view and an end view,
respectively, taken along the lines 7-7 and 8-8, respectively, in Fig. 6 and showing the J-slide used to transfer the
20 tortilla chips from the middle portion to the end portion of the apparatus of the invention and simultaneously to re-orient them;

Fig. 9 is an "edge-on" side view illustrating the endmost portion of the apparatus of the invention, at which point the
25 tortilla chips are automatically being stacked;

Fig. 10 is a section view illustrating the endmost portion of the apparatus as shown in Fig. 9, taken along the line 10-10 therein;

Figs. 11 and 12 are side views, analogous to Fig. 7, showing alternate embodiments of the apparatus of the invention; and

Fig. 13 is a section view taken along the lines 13-13 in Fig. 12.

DETAILED DESCRIPTION OF PREFERRED EMBODIMENTS

As shown in Fig. 1, a tortilla chip 10 customarily has an equilateral triangular shape. Moreover, as shown in Fig. 2, tortilla chips preferably have a certain amount of curvature, which can be imparted to the chips by frying or baking in a curved mold. It will be appreciated that the two edges of the triangle 12 and 14 will be curved, whereas the opposite, "included" edge will be straight. For purposes of describing the invention, the straight edge will be referred to as the base edge B, and the opposite corner of the triangle will be referred to as the apex A.

Furthermore, it will be appreciated that because the chip is an equilateral triangle, its center of gravity 16 will be located one-third of the distance between the base and the apex. Additionally, assuming the tortilla chip has a circular arc of curvature, it will be curved about a line or axis of curvature 20. With this configuration and nomenclature, it will be understood that if one were to lay one of the curved

tortilla chips on a table, it could rock on its "back" surface 22 (Fig. 2), and if one were to press the base edge B down against the table, the apex A would be upturned.

In general, because of their triangular shape, tortilla chips can be (and generally are) cut from a dough sheet in an alternating pattern, i.e., with the apex corners facing in alternating directions. (As a result, there is no "lace" between successive tortilla chips, and this helps to reduce wasted dough.) With the invention, tortilla chips so produced can be kept in such an alternating arrangement, which looks like the four leftmost chips shown in Fig. 3, as the chips are transferred out of their cooking molds.

After they are cooked, the curved, triangular tortilla chips 10 are transferred from their molds to a generally U-shaped, vibrating chute 30 (Fig. 3), the upstream end 32 of which is slightly higher than the downstream end 34. Preferably, the radius of curvature of the inner, concave surface 36 of the U-shaped chute matches the radius of curvature of the convex, "back" surface 22 of the tortilla chips 10. The tortilla chips may be transferred from the cooking apparatus into the U-shaped chute 30 either automatically or by hand, whichever is more convenient. If transferred automatically, the chips will be arranged relatively uniformly, as are the four leftmost chips shown in Fig. 3; if, on the other hand, the chips are transferred to the chute by hand, they will tend to be oriented and

positioned somewhat more randomly, as are the middle two chips shown in Fig. 3. Regardless of how the chips are transferred to the U-shaped chute 30, the invention has been found to work quite well.

5 As the U-shaped chute vibrates, the tortilla chips will move downstream, from left to right as shown in Fig. 3, because the upstream end 32 is located slightly higher than the downstream end 34. Moreover, because the center of gravity of each chip is closer to the base edge B than it is
10 to the apex A, the chips will slide transversely relative to the longitudinal axis of the U-shaped chute such that their centers of gravity move to the bottom of the chute, as illustrated at the right end of the U-shaped chute in Figs. 3 and 4. This causes a lateral or transverse "segregation" of
15 the chips such that the apices A of the chips are laterally offset relative to the base edges B of adjacent chips, as shown at the downstream end 34 of the U-shaped chute. Moreover, because the curvature of the U-shaped chute preferably matches the curvature of the tortilla chips, the
20 tortilla chips also will orient themselves automatically such that the base edges B are aligned substantially parallel to the longitudinal axis of the U-shaped chute 30, i.e., with the line 21 (Fig. 1) passing through the center of gravity 16 and parallel to the base edge of the chip aligned over and
25 extending along the bottom of the trough 30. This feature is particularly advantageous when the chips are loaded into the

chute 30 in a manner which does not result in them being as aligned as might be desired, e.g., by hand.

After they are laterally segregated and properly oriented, the tortilla chips drop from the U-shaped chute 30 into a W-shaped chute 40. As shown in Figs. 3 and 5, a pair of fingers 42 extend slightly from the downstream end of the U-shaped chute over the two troughs 44, 46 which are formed by the two halves of the W-shaped chute 40. As shown in Fig. 5, the fingers 42 are attached to the convex, undersurface of the U-shaped chute, e.g. by welding, and they are laterally spaced such that the apices of the laterally separated tortilla chips "hang up" on the fingers as the chips slide off of the downstream end 34 of the U-shaped chute and drop into the W-shaped chute 40, as illustrated by the chip shown in dashed lines in Fig. 3. As a result, the chips are "flipped" slightly over the vertex 48 of the W-shaped chute, and they automatically fall alternately into the opposite troughs 44 and 46. Thus, all chips having their apices facing in one direction fall into one of the troughs, and all chips having their apices facing in the opposite direction fall into the other trough. The chips slide down along the slanted inner walls 50 of the W-shaped chute, and their base edges B butt up against the sidewalls 52 with the apices positioned near the vertex 48 of the W-shaped chute. See Fig. 5.

As an alternative to the fingers 42, the U-shaped chute may simply have a rectangular notch 43 cut out of the

downstream end of it, as shown in Fig. 3a. In that case, the U-shaped chute, per se, would extend slightly over the upstream end 54 of the W-shaped chute 40.

Like the U-shaped chute 30, the W-shaped chute 40 vibrates, and its upstream end 54 (see Fig. 3) is elevated slightly relative to its downstream end 56 (see Fig. 6). Accordingly, the tortilla chips slide along the slanted inner walls 50 from left to right as shown in Figs. 3 and 6.

Because the tortilla chips are oriented with their apices pointing up, however, such that they move transverse relative to the direction in which the apices "point", they can not be stacked automatically at this point.

As I have discovered, part of the key to being able to stack curved triangular tortilla chips automatically is to orient them such that the apices "lead" as the chips travel downstream. Accordingly, it is necessary to rotate the tortilla chips 120° relative to the orientation they have in the W-shaped chute. This is accomplished easily, effectively, and reliably by means of the structure illustrated in Figs. 6-8.

In particular, at its downstream end 56, the W-shaped chute splits, and each trough thereof terminates in a J-slide 60 which leads the tortilla chips to generally straight (i.e., longitudinally extending), V-shaped vibratory accumulator conveyors 62. As the chips reach the downstream end of the W-

shaped chute, they slide down the J-slides 60 onto the accumulator conveyors 62.

The tortilla chips slide down the J-slides with their base edges B against the sidewalls 52 of the W-shaped chute 40 and, as illustrated, they rotate as they slide down. This results in the tortilla chips landing against upstanding guide walls 66 of the accumulator conveyors 62 with what had been their "leading" corners L (Fig. 6) striking the guide walls first, but with the tortilla chips now rotated by approximately 90°. As the tortilla chips slide all the way down along the slanted support walls 68 and come to rest against the guide walls 66, they continue to rotate about the previously leading corners L and come to rest against the guide walls 66 with their apices A now rotated 120° forward (relative to the direction of travel of the chips). Thus, the apices A now point in the direction in which the chips are traveling.

Because the upstream ends 70 of the accumulator conveyors 62 (see Fig. 6) are slightly higher than the downstream ends 71 (see Fig. 9), the tortilla chips will move from left to right as shown in Figs. 6, 7, and 9 as the accumulator conveyors vibrate. As shown in Fig. 9 -- which is an "edge-on" view looking straight down along the slanted support wall 68 of the top accumulator conveyor of the two shown in Fig. 6 (as indicated by the arrows 9-9) and showing the accumulation of tortilla chips at the downstream end thereof -- the

tortilla chips move along the slanted support wall 68 of each accumulator conveyor until they reach end wall 72 at the downstream end 71 of the accumulator conveyor.

Because the apices, which are now leading, are upturned, the first tortilla chip to reach the end wall 72 will slide up along the end wall 72 such that it is resting on its base edge B with its apex A pointing up. As the next tortilla chip slides into the first tortilla chip, because its apex corner A is upturned, it will slide into and up along the concave, front surface of the tortilla chip in front of it and it, too, will come to stand on its base edge B. In this manner, all of the tortilla chips automatically will "shingle" themselves and slide into a nested, stacked arrangement, as shown at the downstream end 71 of the accumulator conveyor 62.

In addition to re-orienting the tortilla chips by 120° such that their apices lead as the chips travel along the accumulator conveyors 62, it is also key to the success of my invention to maintain this orientation; the V-shaped construction and orientation of the accumulator conveyors ensures that this requirement is met. In particular, because the support walls 68 are slanted relative to horizontal as seen in section in Fig. 8 (in addition to being slanted slightly relative to horizontal from the upstream end of the accumulator conveyor to the downstream end), the tortilla chips will slide down along them until they come to rest against the upstanding guide walls 66 (which define the V-

shaped cross-section in conjunction with the support walls 68) with the curved edges extending between the previously leading corners L and the apices A (see Fig. 6) resting flush against the guide walls 66. (The chips are shown in Fig. 6 as spaced slightly from the guide walls 66; this is for clarity only.) Because the edges rest flush against the guide walls 66 and the weight of the chips keeps them there, the tortilla chips are unable to spin or rotate as they vibrate along the length of the accumulator conveyors and the required, apex-first orientation necessary for automatic stacking is ensured.

(Were the vibratory accumulator conveyors simply flat sheets, the curved or upturned shape of the tortilla chips would make them particularly prone to spinning because, in that case, the chips would make contact with the conveyors only along the line of tangency between their convex back surfaces 22 (Fig. 2) and the conveyors.)

Preferably, the angle ϕ between the guide walls 66 and the support walls 68 (see Fig. 8) is on the order of 65° , i.e., slightly larger than the corner angles of the tortilla chips. (See Fig. 10.) This angle helps to maintain the proper orientation for the chips to "shingle up" on themselves, and because the angle is only slightly wider than the corner angle of the tortilla chips, it keeps the chips aligned and oriented properly for subsequent packaging while at the same time allowing a slight amount of "play," which is important to prevent chip breakage.

Once an appropriate amount of tortilla chips have been so stacked, they are packaged by suitable packaging means (not shown), e.g., an apparatus which can load the tortilla chips into a cylindrical can or other sleeve-type container. As an additional benefit of the invention, the tortilla chips once again will automatically start to shingle themselves into proper stacked arrangement for further packaging -- without the need for operator intervention -- after the process has been interrupted for such packaging (or for some other reason). This is in contrast to other automatic food product stackers, such as cracker stackers, which require an operator to intercede and re-start the stacking process every (or nearly every) time it is interrupted.

It will be appreciated that one may depart from the embodiment of the inventive method and apparatus discussed above without departing from the scope and spirit of the invention. For example, it will be observed from Fig. 6 that the overall width of the conveying line approximately doubles when the line transitions from the W-shaped chute to the two accumulator conveyors. On a commercial scale set-up of the invention, it is contemplated that there could be as many as thirty-six to forty-eight such lines; accordingly, the amount of floor space taken up by the accumulators could be large.

To conserve floor space, rather than J-slides 60, the downstream end of the W-shaped chute could terminate abruptly, as shown in Fig. 11. In that case, the tortilla chips would

simply be permitted to rotate by 120° as they tumble over the downstream-most bottom edge 41 of the W-shaped chute and onto the accumulator conveyor 62. If this approach is used, it is recommended that the angle θ between the inner slanted walls 50 of the W-shaped chute (see Fig. 5) be decreased such that the chips assume more of an upright, standing-on-end configuration to ensure that they spin around their centers of gravity as they fall off the end of the W-shaped chute.

If one desired more control over the tumbling chips but still wished to achieve the space savings of the embodiment shown in Fig. 11, one could maintain the J-slides at the downstream end of the W-shaped chute but decrease the angle θ to approximately 5° to 10° such that the tortilla chips are standing straight up as they enter the J-slide portion. In that case, as illustrated in Figs. 12 and 13, it is suggested that retaining tongues 63 be fastened in place, spaced slightly from the inner slanted walls 50 of the W-shaped chute, to form a narrow gap or passageway 65 through which the chips slide down onto the accumulator conveyors and to prevent the chips from falling off of the W-shaped chute by tumbling over the side walls 52.

Moreover, although the invention has been described and illustrated above using a tortilla chip production run in which the tortilla chips enter the U-shaped chute 32 in alternating fashion, i.e., with the apices of the tortilla chips pointing toward one side of the U-shaped chute and then

the other in alternating fashion, this is not necessary for obtaining the benefit of the invention. For example, the tortilla chips could be stacked after passing through a seasoning apparatus in which they are relatively spread out, and the seasoning apparatus would then feed the tortilla chips onto the U-shaped chute 30. In that case, it will be appreciated that the chips will have a rather random orientation pattern in the chute. Alternatively, it is conceivable that tortilla chips could be fed into the U-shaped chute 30 with just a single orientation, i.e., with all apex corners A facing the same direction. In that case, all chips would fall into the same trough 44 or 46 of the W-shaped chute and would be stacked on a single accumulator conveyor.

Other modifications likely will occur to those having skill in the art and are deemed to be within the scope of the following claims.

CLAIMS:

I claim the following:

1 1. A method of stacking curved, generally triangular
2 chips for subsequent packaging, each of the chips being curved
3 about a line extending parallel to a first, base edge of the
4 chip and having an upturned apex corner opposite the base
5 edge, said method comprising the steps:

6 transporting a succession of said chips in a direction of
7 travel;

8 while transporting the chips, causing them to be oriented
9 such that the apex corners point in the direction of travel;

10 and

11 causing the chips to become stacked automatically by
12 causing the apex corner of one chip in the succession to slide
13 over the base edge of the preceding chip in the succession
14 such that the chips automatically slide into a stacked, nested
15 arrangement.

1 2. The method of claim 1, wherein before the chips are
2 caused to be oriented such that the apex corners point in the
3 direction of travel they are transported with their apex
4 corners pointing in a direction generally perpendicular to the
5 direction of travel.

1 3. The method of claim 2, wherein the chips are caused
2 to be oriented such that the apex corners point in the

3 direction of travel by being rotated in a plane by
4 approximately 120°.

1 4. The method of claim 2, wherein the chips are
2 transported by a first conveyor while their apex corners are
3 pointing in the direction generally perpendicular to the
4 direction of travel and wherein the chips are caused to be
5 oriented such that their apex corners point in the direction
6 of travel by sliding down a J-slide from said first conveyor
7 to a second, accumulator conveyor.

1 5. The method of claim 2, wherein the chips are
2 transported by a first conveyor while their apex corners are
3 pointing in the direction generally perpendicular to the
4 direction of travel and wherein the chips are caused to be
5 oriented such that their apex corners point in the direction
6 of travel by tumbling over an end of said first conveyor onto
7 a second, accumulator conveyor.

1 6. A method of segregating for subsequent packaging a
2 succession of generally triangular chips, each of the chips
3 being curved about a line extending parallel to a first, base
4 edge of the chip and having an upturned apex corner opposite
5 the base edge, the apex corners of some of the chips in the
6 succession pointing in generally one direction and the apex

7 corners of the other chips in the succession pointing in
8 generally the opposite direction, said method comprising:
9 transporting the chips in a direction of travel;
10 causing the chips to be oriented such that the line about
11 which each chip is curved is substantially parallel to the
12 direction of travel;
13 causing the chips to move laterally relative to the
14 direction of travel such that their centers of gravity become
15 generally aligned, the base edges of the chips pointing in one
16 direction become generally aligned with each other, and the
17 base edges of the chips pointing in the opposite direction
18 become generally aligned with each other, whereby the apex
19 corners of the chips pointing in one direction extend
20 laterally beyond the base edges of the chips facing in the
21 opposite direction and vice-versa; and
22 separating the succession of chips into two separate
23 conveyor troughs by tripping or partially flipping the chips
24 by means of their apex corners, with the chips pointing in one
25 direction going to one conveyor trough and the chips pointing
26 in the other direction going to the other conveyer trough.

1 7. The method of claim 6, wherein the chips are
2 transported along the bottom of a vibratory U-shaped chute and
3 the chips are caused to move laterally relative to the
4 direction of travel such that their centers of gravity become
5 generally aligned, the base edges of the chips pointing in one

6 direction become generally aligned with each other, and the
7 base edges of the chips pointing in the opposite direction
8 become generally aligned with each other by means of vibrating
9 the U-shaped chute.

1 8. The method of claim 6, wherein the two separate
2 conveyor troughs are provided by means of a W-shaped chute
3 having a vertex and wherein the chips are tripped or partially
4 flipped so as to fall over the vertex and into one trough or
5 the other.

1 9. The method of claim 6, wherein the chips are
2 transported along the bottom of a vibratory U-shaped chute and
3 the chips are caused to move laterally relative to the
4 direction of travel such that their centers of gravity become
5 generally aligned, the base edges of the chips pointing in one
6 direction become generally aligned with each other, and the
7 base edges of the chips pointing in the opposite direction
8 become generally aligned with each other by means of vibrating
9 the U-shaped chute;

10 wherein the two separate conveyor troughs are provided by
11 means of a W-shaped chute that is aligned with the U-shaped
12 chute, is disposed generally below an end of the U-shaped
13 chute, and has a vertex; and

14 wherein the chips are tripped or partially flipped so as
15 to fall over the vertex and into one trough or the other by

16 means of a pair of fingers extending from an end of the U-
17 shaped chute.

1 10. A method of segregating and stacking for subsequent
2 packaging a succession of curved, generally triangular chips,
3 each of the chips being curved about a line extending parallel
4 to a first, base edge of the chip and having an upturned apex
5 corner opposite the base edge, the apex corners of some of the
6 chips in the succession pointing in generally one direction
7 and the apex corners of the other chips in the succession
8 pointing in generally the opposite direction, said method
9 comprising:

10 transporting the chips in a direction of travel;

11 causing the chips to be oriented such that the line about
12 which each chip is curved is substantially parallel to the
13 direction of travel;

14 causing the chips to move laterally relative to the
15 direction of travel such that their centers of gravity become
16 generally aligned, the base edges of the chips pointing in one
17 direction become generally aligned with each other, and the
18 base edges of the chips pointing in the opposite direction
19 become generally aligned with each other, whereby the apex
20 corners of the chips pointing in one direction extend
21 laterally beyond the base edges of the chips facing in the
22 opposite direction and vice-versa;

23 separating the succession of chips into two conveyor
24 troughs by tripping or partially flipping the chips by means
25 of their apex corners, with the chips pointing in one
26 direction going to one conveyor trough and the chips pointing
27 in the other direction going to the other conveyer trough;
28 while continuing to transport the chips in two
29 successions by means of said conveyor troughs, causing the
30 chips to be oriented such that the apex corners point in the
31 direction of travel; and
32 causing the chips in the two successions to become
33 stacked automatically by causing the apex corner of one chip
34 in each of the two successions to slide over the base edge of
35 the preceding chip in each of the two successions such that
36 the chips automatically slide into a stacked, nested
37 arrangement.

1 11. An apparatus for segregating and stacking for
2 subsequent packaging a succession of curved, generally
3 triangular chips, the apparatus comprising:

4 a first, vibratory, generally U-shaped conveyor chute for
5 transporting the chips and having an upstream end and a
6 downstream end;

7 a second, generally W-shaped conveyor chute comprising
8 two troughs, said second conveyor chute having an upstream end
9 and a downstream end, the upstream end of the second conveyor
10 chute being positioned to receive chips from the downstream

11 end of the first conveyor chute and configured to receive
12 chips into both of said troughs for transport thereby;

13 means for rotating the chips by about 120° in a plane
14 about their centers of gravity;

15 two accumulator conveyors which automatically accumulate
16 and stack the chips in a nested, stacked arrangement, each of
17 the two accumulators being positioned to receive chips from
18 one of the two troughs of the W-shaped conveyor chute.

1 12. The apparatus of claim 11, further comprising a pair
2 of fingers extending from the downstream end of the first, U-
3 shaped conveyor chute and positioned above the two troughs of
4 the second, W-shaped conveyor chute to trip or flip each of
5 the chips into one trough or the other depending on the
6 orientation of each of the chips.

1 13. The apparatus of claim 11, wherein the downstream
2 end of the first, U-shaped conveyor chute has a notch disposed
3 above the upstream end of the second, W-shaped conveyor chute
4 and configured to trip or flip each of the chips into one
5 trough or the other depending on the orientation of each of
6 the chips.

1 14. The apparatus of claim 11, wherein the second, W-
2 shaped conveyor chute is vibratory.

1 15. The apparatus of claim 11, wherein the accumulator
2 conveyors are vibratory.

1 16. The apparatus of claim 11, wherein the means for
2 rotating the chips comprise J-slides which transfer the chips
3 from the troughs to the accumulator conveyors.

1 17. The apparatus of claim 16, wherein the means for
2 rotating the chips comprise a lower edge of the downstream end
3 of the second, W-shaped conveyor chute and wherein the
4 downstream end of the second, W-shaped conveyor chute is
5 positioned sufficiently above the accumulator conveyors that
6 the chips rotate by approximately 120° as they tumble over
7 said lower edge and onto the accumulator conveyors.

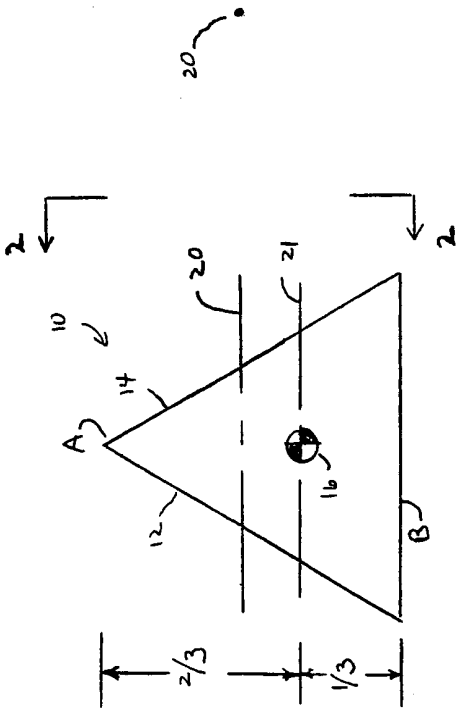

Fig. 1

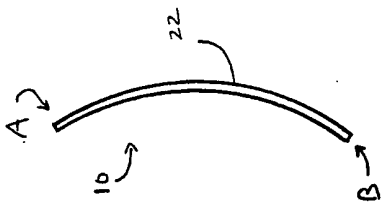

Fig. 2

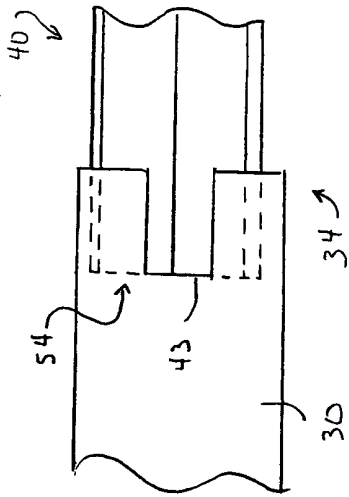

Fig. 3a

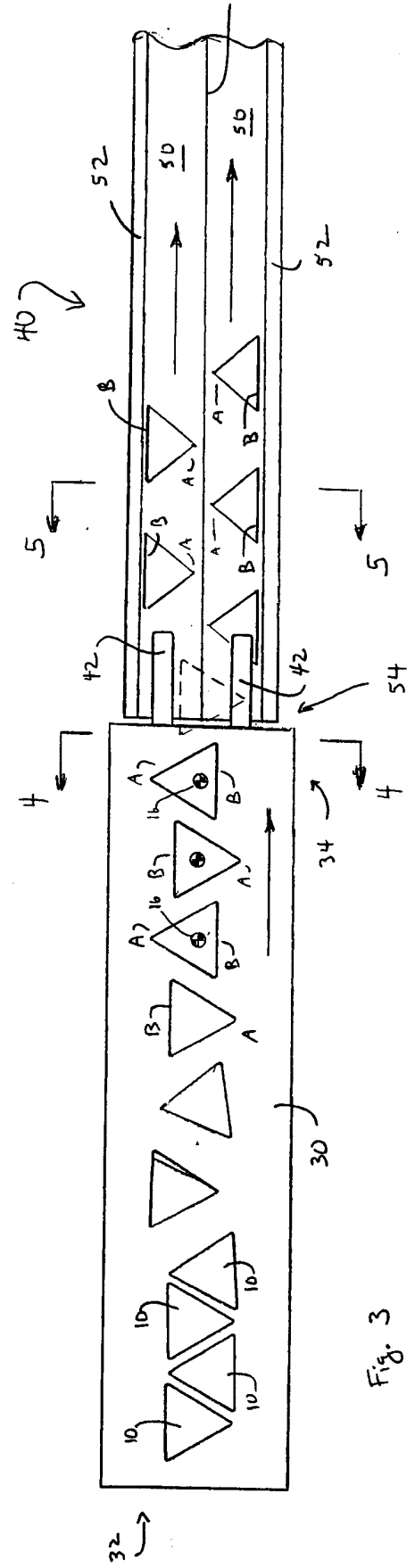

Fig. 3

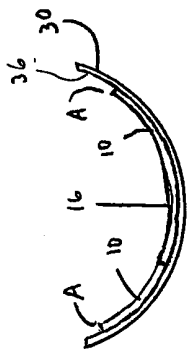

Fig 4

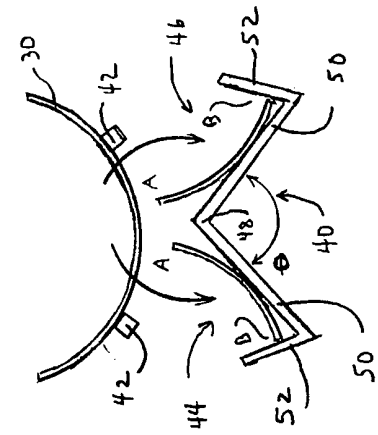

Fig 5

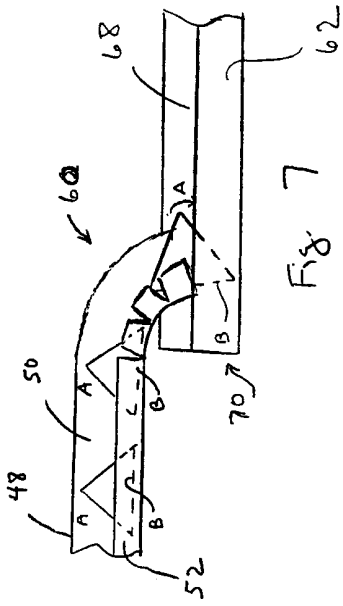

Fig 7

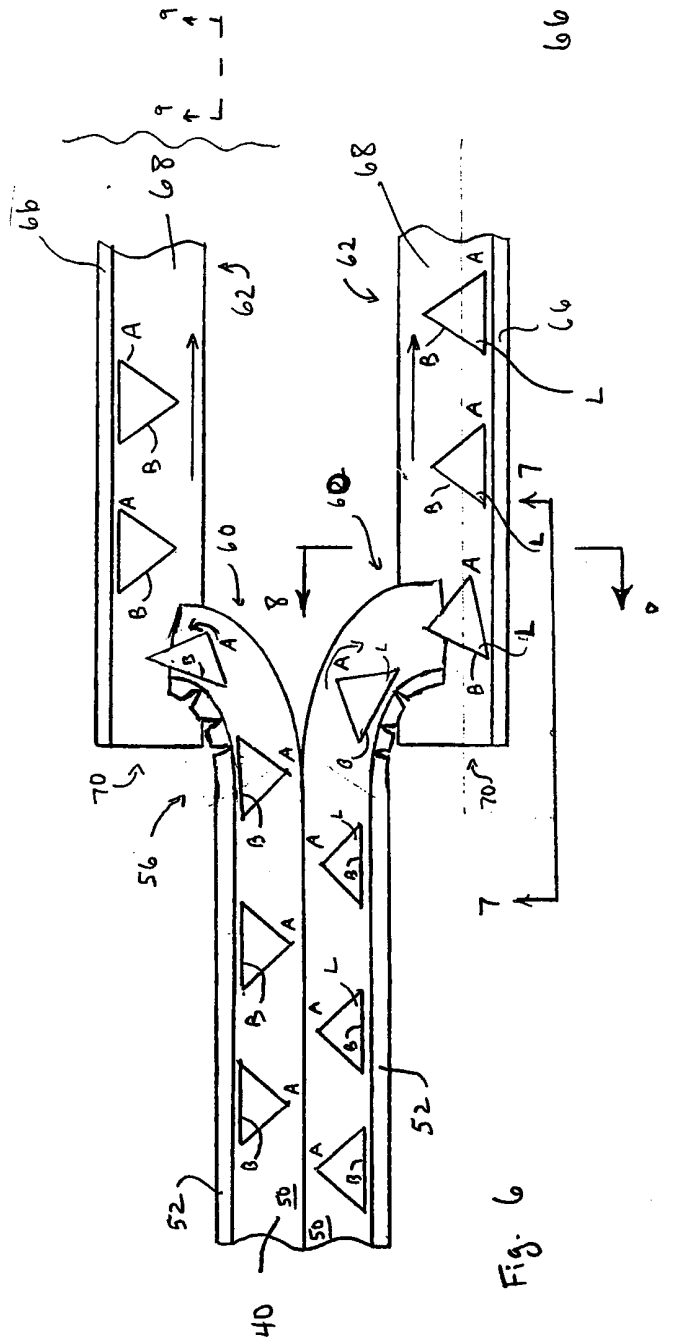

Fig. 6

Fig 8

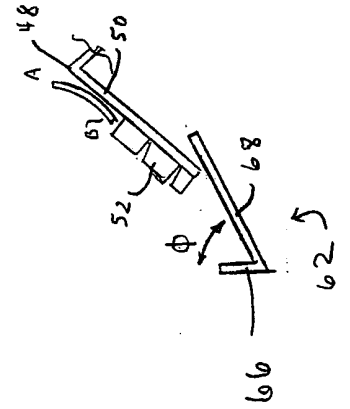

Fig. 9

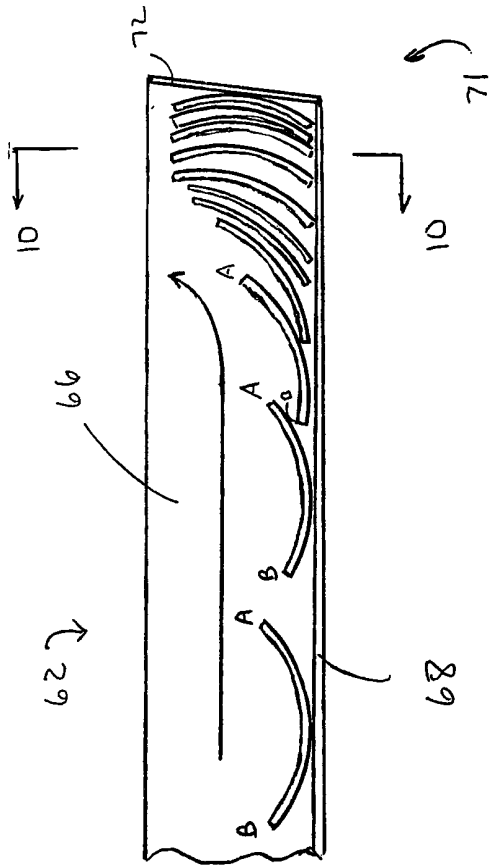

Fig. 10

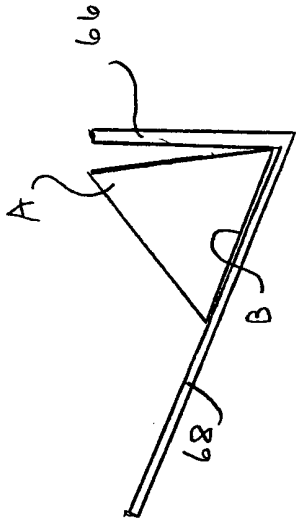

Fig. 11

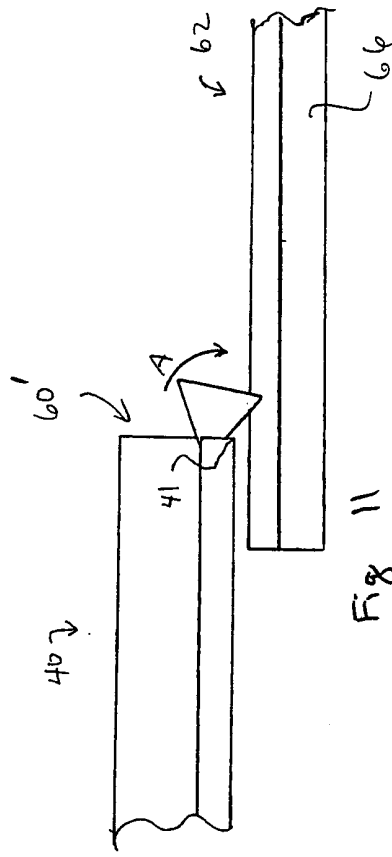

Fig. 12

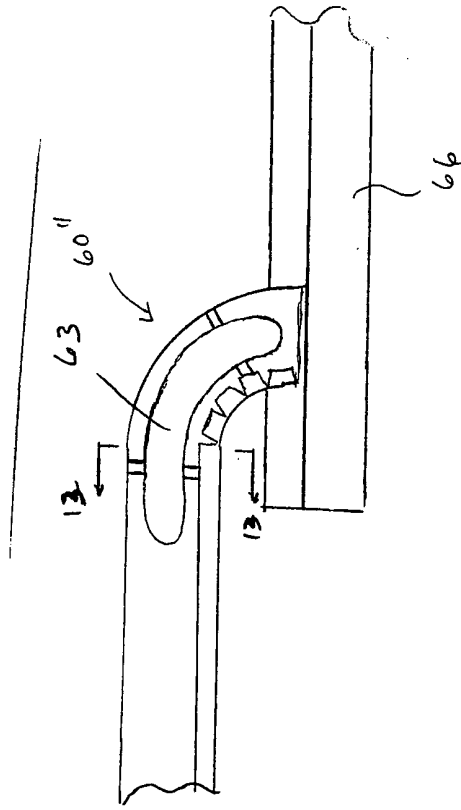
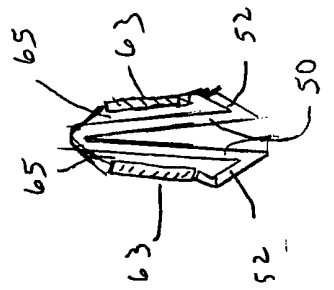

Fig. 13



INTERNATIONAL SEARCH REPORT

International Application No

PCT/US 00/14310

A. CLASSIFICATION OF SUBJECT MATTER
 IPC 7 B65G57/32 B65G47/24

According to International Patent Classification (IPC) or to both national classification and IPC

B. FIELDS SEARCHED

Minimum documentation searched (classification system followed by classification symbols)

IPC 7 B65G B65B

Documentation searched other than minimum documentation to the extent that such documents are included in the fields searched

Electronic data base consulted during the international search (name of data base and, where practical, search terms used)

EPO-Internal, WPI Data

C. DOCUMENTS CONSIDERED TO BE RELEVANT

Category °	Citation of document, with indication, where appropriate, of the relevant passages	Relevant to claim No.
A	US 5 873 448 A (JANG MING-JYI ET AL) 23 February 1999 (1999-02-23) abstract; figures ---	1, 11
A	US 4 546 870 A (COGO BRUNO) 15 October 1985 (1985-10-15) abstract; figures ---	1, 5, 6, 11, 12, 16
A	US 2 831 564 A (M. PAVESI) 22 April 1958 (1958-04-22) the whole document ---	1, 9, 11, 13
A	US 4 105 108 A (LAUER GEORGE E) 8 August 1978 (1978-08-08) abstract; figures ---	1, 9, 11, 13
	-/--	

Further documents are listed in the continuation of box C.

Patent family members are listed in annex.

° Special categories of cited documents :

- "A" document defining the general state of the art which is not considered to be of particular relevance
- "E" earlier document but published on or after the international filing date
- "L" document which may throw doubts on priority claim(s) or which is cited to establish the publication date of another citation or other special reason (as specified)
- "O" document referring to an oral disclosure, use, exhibition or other means
- "P" document published prior to the international filing date but later than the priority date claimed

- "T" later document published after the international filing date or priority date and not in conflict with the application but cited to understand the principle or theory underlying the invention
- "X" document of particular relevance; the claimed invention cannot be considered novel or cannot be considered to involve an inventive step when the document is taken alone
- "Y" document of particular relevance; the claimed invention cannot be considered to involve an inventive step when the document is combined with one or more other such documents, such combination being obvious to a person skilled in the art.
- "&" document member of the same patent family

Date of the actual completion of the international search

18 September 2000

Date of mailing of the international search report

27/09/2000

Name and mailing address of the ISA

European Patent Office, P.B. 5818 Patentlaan 2
 NL - 2280 HV Rijswijk
 Tel. (+31-70) 340-2040, Tx. 31 651 epo nl,
 Fax: (+31-70) 340-3016

Authorized officer

Van Rollegem, F

INTERNATIONAL SEARCH REPORT

In: International Application No

PCT/US 00/14310

C.(Continuation) DOCUMENTS CONSIDERED TO BE RELEVANT

Category °	Citation of document, with indication, where appropriate, of the relevant passages	Relevant to claim No.
A	CH 563 931 A (SIG SCHWEIZ INDUSTRIEGES) 15 July 1975 (1975-07-15) the whole document -----	1,11

INTERNATIONAL SEARCH REPORT

Information on patent family members

International Application No

PCT/US 00/14310

Patent document cited in search report	Publication date	Patent family member(s)	Publication date
US 5873448	A	23-02-1999	NONE
<hr/>			
US 4546870	A	15-10-1985	IT 1157862 B 18-02-1987
			CA 1199835 A 28-01-1986
			DE 3304025 A 13-10-1983
			ES 519962 D 01-03-1984
			ES 8402494 A 01-05-1984
			FR 2521400 A 19-08-1983
			JP 3014411 B 26-02-1991
			JP 58152435 A 10-09-1983
<hr/>			
US 2831564	A	22-04-1958	NONE
<hr/>			
US 4105108	A	08-08-1978	NONE
<hr/>			
CH 563931	A	15-07-1975	NONE
<hr/>			