



- (51) **International Patent Classification:**
A61F 2/16 (2006.01) *A61F 2/76* (2006.01)
A61F 2/14 (2006.01)
- (21) **International Application Number:** PCT/US2012/030127
- (22) **International Filing Date:** 22 March 2012 (22.03.2012)
- (25) **Filing Language:** English
- (26) **Publication Language:** English
- (30) **Priority Data:** 61/467,352 24 March 2011 (24.03.2011) US
- (71) **Applicant** (for all designated States except US): **POWER-VISION, INC.** [US/US]; 298 Harbor Boulevard, Belmont, CA 94002 (US).
- (72) **Inventor; and**
- (75) **Inventor/Applicant** (for US only): **MATTHEWS, Gregory, V.** [US/US]; 298 Harbor Boulevard, Belmont, CA 94002 (US).
- (74) **Agents:** **ZLOGAR, Thomas M.** et al.; Shay Glenn LLP, 2755 Campus Drive, Suite 210, San Mateo, CA 94403 (US).
- (81) **Designated States** (unless otherwise indicated, for every kind of national protection available): AE, AG, AL, AM, AO, AT, AU, AZ, BA, BB, BG, BH, BR, BW, BY, BZ, CA, CH, CL, CN, CO, CR, CU, CZ, DE, DK, DM, DO, DZ, EC, EE, EG, ES, FI, GB, GD, GE, GH, GM, GT, HN, HR, HU, ID, IL, IN, IS, JP, KE, KG, KM, KN, KP, KR, KZ, LA, LC, LK, LR, LS, LT, LU, LY, MA, MD, ME, MG, MK, MN, MW, MX, MY, MZ, NA, NG, NI, NO, NZ, OM, PE, PG, PH, PL, PT, QA, RO, RS, RU, RW, SC, SD, SE, SG, SK, SL, SM, ST, SV, SY, TH, TJ, TM, TN, TR, TT, TZ, UA, UG, US, UZ, VC, VN, ZA, ZM, ZW.
- (84) **Designated States** (unless otherwise indicated, for every kind of regional protection available): ARIPO (BW, GH, GM, KE, LR, LS, MW, MZ, NA, RW, SD, SL, SZ, TZ, UG, ZM, ZW), Eurasian (AM, AZ, BY, KG, KZ, MD, RU, TJ, TM), European (AL, AT, BE, BG, CH, CY, CZ, DE, DK, EE, ES, FI, FR, GB, GR, HR, HU, IE, IS, IT, LT, LU, LV, MC, MK, MT, NL, NO, PL, PT, RO, RS, SE, SI, SK, SM, TR), OAPI (BF, BJ, CF, CG, CI, CM, GA, GN, GQ, GW, ML, MR, NE, SN, TD, TG).
- Published:**
— without international search report and to be republished upon receipt of that report (Rule 48.2(g))



(54) **Title:** INTRAOCULAR LENS LOADING SYSTEMS AND METHODS OF USE

(57) **Abstract:** Intraocular lens loading devices, system, and methods of use. The device and systems can be used to load an intraocular lens into a cartridge, from which it can be delivered into a patient's eye. The devices and systems can also be used to simply advance an intraocular lens through any type of loading or delivery device.

INTRAOCULAR LENS LOADING SYSTEMS AND METHODS OF USE**CROSS REFERENCE TO RELATED APPLICATIONS**

[0001] This application claims the benefit of U.S. Provisional Application No. 61/467,352, filed March 24, 2011, the disclosure of which is incorporated by reference herein.

5 [0002] This application is related to U.S. Application No. 12/178,565, filed July 23, 2008, Publication No. 2009-0030425; U.S. Application No. 13/180,427, filed July 11, 2011, Publication No. 2012-002547; U.S. Provisional Application No. 61/613,929, filed March 21, 2012; and U.S. Provisional Application No. 61/557,237, filed November 8, 2011. The disclosure of each of these applications is incorporated by reference herein.

10 **INCORPORATION BY REFERENCE**

[0003] All publications and patent applications mentioned in this specification are herein incorporated by reference to the same extent as if each individual publication or patent application was specifically and individually indicated to be incorporated by reference.

BACKGROUND

15 [0004] A variety of intraocular lens loading and delivery devices, systems, and methods of use have been described in recent years. Many of them fail to adequately protect the intraocular lens from damage during at least a portion of the loading or delivery of the lens. This can be particularly true if the lens undergoes some degree of deformation during the loading or delivery of the lens, if portions of the lens are relatively delicate and are susceptible to damage during
20 loading or delivery, or if the lens has at least portions that are coupled together and the connections might be susceptible to damage during loading or delivery.

[0005] Loading and delivery devices, systems, and method of use are needed that can effectively load or deliver an intraocular lens without damaging the lens.

SUMMARY OF THE DISCLOSURE

25 [0006] A first aspect of the disclosure is a method of loading a fluid-filled intraocular lens into a delivery or storage device, comprising: providing a fluid-filled intraocular lens comprising an optic portion and a peripheral portion; applying loading forces with a loading instrument on the optic portion and on a first portion of the peripheral portion that is less flexible than a second portion of the peripheral portion, wherein the method of loading does not apply a loading force
30 on the second portion of the peripheral portion; and loading the intraocular lens into a delivery or storage device using the loading instrument.

[0007] In some embodiments applying the loading forces comprises applying a loading force to the optic portion with a first surface of the loading instrument and applying a loading force to

the first portion of the peripheral portion with a second surface of the loading instrument. The first surface can be distal to the second surface. The first surface can be on a first side of the loading instrument and the second surface can be on a second side of the loading instrument.

5 [0008] In some embodiment applying loading forces comprises applying generally distally directed forces on a side of the optic portion and on the first portion of the peripheral portion.

[0009] In some embodiments loading comprises deforming at least a portion of the lens.

10 [0010] In some embodiments the peripheral portion is in fluid communication with the optic portion, and wherein the first portion of the peripheral portion is coupled to the optic portion and the second portion of the peripheral portion extends from the first portion.

[0011] In some embodiments the method further comprises positioning the intraocular lens in a lens receiving area created by a loading instrument distal region and a loading tray such that a first haptic extends distally relative to the optic portion and a trailing haptic extends proximally relative to the optic portion, wherein the first portion of the peripheral portion is a buttress of the first haptic and the second portion extends from the buttress and is adapted to engage a capsular bag.

15 [0012] In some embodiments the method further comprises positioning a loading instrument distal portion relative to a loading tray so that the loading instrument distal portion and the loading tray create an intraocular lens positioning region, and positioning the intraocular lens in the lens positioning region prior to applying the loading forces.

20 [0013] One aspect of the disclosure is a method of loading a fluid-filled intraocular lens into a delivery or storage device, comprising: providing a fluid-filled intraocular lens comprising an optic portion and a first haptic, the first haptic comprising a connection portion coupled to the optic portion and a second portion extending from the connection portion; applying a loading force with a loading instrument on the optic portion and on the connection portion of the first haptic without applying a loading force on the second portion of the first haptic; and loading the intraocular lens into a delivery or storage device.

[0014] In some embodiments the method further comprises positioning the fluid-filled intraocular lens in a lens positioning area of a loading device.

30 [0015] In some embodiments applying the loading forces comprises applying a loading force on the optic portion with a first surface of the loading instrument and applying a loading force on the connection portion with a second surface of the loading instrument. The first surface can be distal to the second surface. The first surface can be on a first side of the loading instrument and the second surface can be on a second side of the loading instrument.

[0016] In some embodiments applying loading forces comprises applying generally distally directed forces on the optic portion and the connection portion.

[0017] In some embodiments loading comprises deforming at least a portion of the lens.

[0018] In some embodiments the method further comprises positioning the intraocular lens
5 in a lens positioning area created by a loading instrument distal region and a loading tray such that the first haptic extends proximally relative to the optic portion and a leading haptic extends distally relative to the optic portion.

[0019] One aspect of the disclosure is a method of preparing a fluid-filled intraocular lens for deformation into a delivery or storage device: positioning a plunger distal portion relative to a
10 loading tray so that the plunger distal portion and the loading tray create an intraocular lens positioning region; and positioning an intraocular lens in the lens positioning region so that a lens engaging surface of the plunger distal portion is disposed relative to the fluid-filled optic portion so that the lens engaging surface is positioned to apply a loading force on the fluid-filled optic portion.

[0020] In some embodiments positioning the intraocular lens comprises positioning the
15 intraocular lens so that the lens engaging surface of the plunger distal portion is positioned distal to a trailing haptic of the intraocular lens.

[0021] In some embodiments positioning the intraocular lens comprises positioning the
20 intraocular lens so that a second lens engaging surface of the plunger is disposed relative to a haptic connection portion of the intraocular lens so that the second lens engaging surface is adapted to apply a loading force on the haptic connection portion.

[0022] In some embodiments positioning the intraocular lens comprises positioning the
25 intraocular lens so that a trailing haptic extends proximally from the optic portion. Positioning the intraocular lens can comprise positioning the intraocular lens so that the lens engaging surface of the plunger distal portion is positioned distal to the trailing haptic of the intraocular lens. Positioning the intraocular lens can comprise positioning the intraocular lens so that a leading haptic extends distally from the optic portion.

[0023] In some embodiments positioning the intraocular lens comprises positioning the
30 intraocular lens so that a second lens engaging surface of the plunger distal portion is disposed relative to a haptic connection portion so that the second lens engaging surface is adapted to apply a loading force on the haptic connection portion without applying a loading force on a haptic body portion that extends from the haptic connection portion. The lens engaging surface can be disposed distal relative to the second lens engaging surface.

[0024] One aspect of the disclosure is a method of preparing a fluid-filled intraocular lens for
35 deformation into a delivery or storage device, comprising: positioning a plunger distal portion

relative to a loading tray so that the plunger distal portion and the loading tray create an intraocular lens positioning region; and positioning an intraocular lens in the lens positioning region so that a first lens engaging surface of the plunger distal portion is disposed relative to a fluid-filled optic portion of the intraocular lens so that it can apply a loading force on the fluid-filled optic portion, and so that a second lens engaging surface of the plunger is disposed relative to a peripheral portion of the intraocular lens so that it can apply a loading force on the peripheral portion of the intraocular lens.

[0025] In some embodiments positioning the intraocular lens comprises positioning the intraocular lens so that the first lens engaging surface of the plunger distal portion is positioned distal to a trailing haptic of the intraocular lens.

[0026] In some embodiments positioning the intraocular lens comprises positioning the intraocular lens so that the second lens engaging surface of the plunger is disposed relative to a haptic connection portion of the intraocular lens so that the it can apply a loading force on the haptic connection portion.

[0027] In some embodiments positioning the intraocular lens comprises positioning the intraocular lens so that a trailing haptic extends proximally from the optic portion. Positioning the intraocular lens can comprise positioning the intraocular lens so that the first lens engaging surface of the plunger distal portion is positioned distal to the trailing haptic of the intraocular lens. Positioning the intraocular lens can comprise positioning the intraocular lens so that a leading haptic extends distally from the optic portion.

[0028] In some embodiments the first lens engaging surface is disposed distal relative to the second lens engaging surface.

[0029] One aspect of the disclosure is a method of deploying a fluid-filled intraocular lens from a delivery device, comprising: applying a loading force on an optic portion of a fluid-filled intraocular lens to load the intraocular lens into a cartridge; and advancing the intraocular lens out of the cartridge solely by delivering a fluid through the cartridge.

[0030] In some embodiments the method further comprises applying a loading force on a first portion of a peripheral portion of the intraocular lens that is less flexible than a second portion of the peripheral portion of the intraocular lens.

[0031] In some embodiments the method further comprises applying a loading force on a haptic connection portion that is less flexible than a haptic body portion without applying a loading force on the haptic body portion.

[0032] One aspect of the disclosure is a loading instrument adapted to advance an intraocular lens through a loading device, comprising: an elongate portion and a distal lens engaging portion extending distally from the elongate portion, the distal lens engaging portion comprising

a first lens engaging surface adapted to engage an optic portion and a second lens engaging surface adapted to engage a peripheral portion of the intraocular lens.

[0033] In some embodiments the first lens engaging surface is positioned distal to the second lens engaging surface.

5 [0034] In some embodiments the first lens engaging surface is disposed on a first side of the loading instrument and the second lens engaging surface is disposed on a second side of the loading instrument.

[0035] In some embodiments the distal lens engaging portion comprises a generally flat base portion, and wherein the first and second lens engaging surfaces extend from the base portion.

10 The base portion can be substantially perpendicular to the first and second lens engaging surfaces.

BRIEF DESCRIPTION OF THE DRAWINGS

[0036] A better understanding of the features and advantages of the present disclosure will be obtained by reference to the following detailed description that sets forth illustrative
15 embodiments, in which the principles of the disclosure are utilized, and the accompanying drawings of which:

[0037] Fig. 1 shows an exemplary system for at least loading an intraocular lens into a cartridge

[0038] Figs. 2A and 2B illustrate an exemplary loading instrument.

20 [0039] Fig. 3 shows a detailed view of a distal region of the loading instrument from Figures 2A and 2B.

[0040] Fig. 4 illustrates an exemplary cartridge.

[0041] Figs. 5A and 5B illustrate an exemplary loading instrument positioned relative to a loading tray to create a lens positioning area.

25 [0042] Figs. 6A-6C illustrate an exemplary fluid-filled intraocular lens positioned in the lens positioning area with lens engaging surfaces adapted to applying loading forces to the optic portion and to a connection portion of the trailing haptic.

[0043] Fig. 7 illustrates an exemplary actuation of the loading instrument, causing loading forces to be applied to the optic and haptic connection portion, thereby loading the intraocular
30 lens into the cartridge.

[0044] Fig. 8 illustrates a loading tray and a loading instrument after the loading instrument has been advanced such that the loading instrument distal portion is in the distal portion of the loading tray.

[0045] Fig. 9 illustrates exemplary folding axes along which the intraocular lens from Figures 6A-7 can fold.

DETAILED DESCRIPTION OF THE DISCLOSURE

[0046] The disclosure herein relates to intraocular lens loading systems and methods of use.

5 The systems can be used to load an intraocular lens into a delivery device or to advance the lens through any type of medical device. The systems can be used to deliver an intraocular lens into a patient's eye. The systems can be used to both load an intraocular lens into a delivery device and deliver the intraocular lens into the patient's eye.

[0047] An intraocular lens is typically implanted within a patient's eye to replace the
10 function of an eye's native lens. The native lens can become diseased (e.g., cataract), or the lens can lose the ability to accommodate over time (i.e., presbyopia). In either case, the native lens can be removed and replaced with an intraocular lens. To deliver the lens through as small an incision as reasonable, the lens typically undergoes some type of deformation during the loading and/or delivery process to reduce the profile of the lens. Additionally, some intraocular lenses
15 include components that can be reconfigured relative to other components, and the controlled positioning or deformation of these components during the loading and/or delivery steps can enhance the loading and/or delivery.

[0048] The loading systems described herein can be used to load or advance ocular implants such as intraocular lenses, and can be flexible non-accommodating intraocular lenses or
20 accommodating intraocular lenses. The implants have at least one component that can be reconfigured or deformed during the loading and/or delivery steps. In some embodiments the loading systems can be used to load and deliver accommodating intraocular lenses that have one or more flowable media therein. For example, the loading systems can be used to load and deliver fluid-filled accommodating intraocular lenses, while in some embodiments the lens can
25 comprise a low viscosity polymeric material.

[0049] Exemplary fluid-filled accommodating intraocular lenses with one or more haptics that can be loaded and/or delivered using the systems herein are described in U.S. Provisional Application. No 61/557,237, filed 11/8/11, U.S. Pat. No. 7,122,053, U.S. Pat. No. 7,261,737, U.S. Pub. No. 2007/0203578, U.S. Pat. No. 7,637,947, U.S. Pat. No. 7,247,168, U.S. Pub. No.
30 2008/0306588, U.S. Pub. No. 2009/0005865, U.S. Pat. No. 7,857,850, and U.S. Pub. No. 2009/0264998, the disclosures of which are incorporated by reference herein. Additional features and details of loading and/or delivering a lens that can be incorporated into the disclosure herein can be found in U.S. Pub. No. 2009/0030425, the disclosure of which is incorporated by reference herein.

[0050] Figure 1 illustrates an exemplary intraocular lens loading system. Lens loading system 10 includes cartridge 12, loading tray 14, and plunger 16. In general, plunger 16 and loading tray 14 are configured to load an intraocular lens into cartridge 12. Once in cartridge 12, the lens can be kept there for any length of time (including storage), or the lens may be delivered shortly thereafter from cartridge 12 into a patient. Cartridge 12 is positioned with respect to loading tray 14 such that cartridge and loading tray 14 are in secured engagement. In some embodiments cartridge 12 and loading tray 14 are integral such that cartridge 12 is not adapted to be disassociated from loading tray 14. In some embodiments cartridge 12 shown need not be part of the system, such that the system comprises the loading tray and plunger without a cartridge. When plunger 16 is positioned within loading tray 14 in the position as shown in Figure 1, the distal portion of plunger 16 and one or more inner surfaces of loading tray 14 create lens positioning region 18, which is adapted to receive an implant therein that is to be loaded into cartridge 12.

[0051] Figures 2A and 2B illustrate an exemplary loading instrument in the form of plunger 20. Plunger 20 includes distal lens interface portion 22, proximal portion 26, and central portion 24 extending between distal portion 22 and proximal portion 26. Distal lens interface portion 22 is generally the portion that interfaces with the implant and portions of which are adapted to apply one or more loading forces on one or more portions of the intraocular lens, details of which are shown in Figure 3. Plunger 20 includes seals 28 and 30 shown as O-rings. The central portion includes keying element 32, which is adapted to interact with a loading tray channel to restrict rotation of the plunger with respect to the loading tray. Keying element 32 is shown as a region of the plunger that is raised with respect to adjacent regions of the plunger housing. Key element 32 resists rotation of the plunger when, for example, tightening a leuc lock syringe to the proximal end of the plunger, as described below. It also acts as the loading tray plug that occupies space in the loading tray channel to make the handpiece circular for handling ergonomics. Plunger 20 also includes detent 25, which is adapted to interact with the loading tray and prevent movement therebetween. The detent acts as a positive stop feature to indicate to an operator that the lens has been fully advanced with respect to the cartridge. The detent also acts as a safety against the cartridge/loading tray assembly moving forward relative to the plunger as pressure is developed behind the lens during delivery. Proximal portion 26 also includes a leuc lock 34, which is adapted to secure the loading tray with a syringe, which is described below.

[0052] Figure 2B shows plunger 20 (similar components from Figure 2A not labeled for clarity) having an internal lumen defined by inner surface 36 extending through the central portion of plunger 20. In the proximal region of the plunger, lumen wall 36 radially extends to

receiving wall 42, which defines receiving area 40. In some embodiments described below the receiving area is adapted to receive a distal portion of a syringe. Lumen wall 36 extends through the plunger to distal port 38, such that the lumen extending through the plunger allows lens distal interfacing portion 22, and any lens positioned therein, to be in fluid communication with the proximal region of the plunger. In some embodiments viscoelastic fluid or other types of fluid can be advanced through the plunger lumen from the proximal end using a syringe.

[0053] Figure 3 illustrates distal portion 22 and a portion of central portion 24 of plunger 20 from Figures 2A and 2B. Lens interfacing portion 22 includes base 56, side walls 57 and protrusions 50 and 52. Base 56 provides axial stiffness while maintaining contact with the lens during a portion of the loading process in which the lens is folded (described below). Protrusion 50 is positioned further distally than protrusion 52, and lens engaging surface 51 is disposed further distally than lens engaging surface 53. Stated alternatively, the lens contact surfaces are asymmetrical. Protrusions 50 and 52 include lens engaging surfaces 51 and 53, respectively, which are each adapted to engage a portion of the ocular implant and apply a loading force on a portion of the implant. Lens engaging surfaces 51 and 53 are generally flattened surfaces, but can have other surface shapes or configurations as well. Lens engaging surface 51 is disposed on one side of the distal portion 22 while lens engaging surface 53 is disposed on the other side of distal portion 22. The surfaces 51 and 53 are generally perpendicular to the base surface 56. Extending axially from lens engaging surface 53 is tab 54, which has a generally flat configuration. The tab provides sliding support for a portion of the implant, such as a haptic. Lens interfacing portion 22 also includes rib 55, which reduces the potential of longitudinal buckling of base 56. Also shown are seals 28 and 30 of the plunger.

[0054] Figure 4 illustrates an exemplary cartridge 60. Cartridge 60 includes proximal end 62 and distal end 64. Cartridge 60 has a lumen extending therein from the proximal end to the distal end through which a lens can be advanced. The cartridge includes proximal portion 66, tapering central portion 68, and distal portion 70. The lens is ejected from cartridge 60 out of distal portion 70. Proximal portions 66 and distal portions 70 have generally uniform inner diameters. Distal portion 70 has a curvilinearly shaped distal end. Cartridge 60 also includes locking features 72 and 74, with engaging surfaces 73 and 75. Locking features 72 and 74 are adapted to securely engage elements on the loading tray to securely engage the cartridge to the loading tray.

[0055] In some embodiments the implant is an intraocular lens that is to be delivered into the patient's eye to replace the native lens. The intraocular lens can be accommodating or non-accommodating. A non-accommodating intraocular lens can be adapted to be deformed when being loaded with the delivery systems, but is adapted to remain undeformed when implanted

within an eye to provide a single power implant when implanted within the eye. In the exemplary method of use below a delivery system is used to load and deliver an intraocular lens with an optic portion and a peripheral portion. The peripheral portion includes two haptics that are coupled to the optic portion and which extend radially from the optic portion. The haptics can be a deformable or flexible material, such as a deformable polymeric material. The loading system can be used with a fluid-filled accommodating intraocular lens wherein the haptics are in fluid communication with the optic portion, such as in the accommodating intraocular lenses incorporated by reference above.

[0056] Figure 5A shows the system from Figure 1 in a configuration ready to receive an implant for loading into the cartridge. The loading instrument, in the form of plunger 16, has been positioned relative to loading tray 14 so that the plunger distal portion and the loading tray create an intraocular lens positioning region. System 10 includes cartridge 12 securely engaged with loading tray 14, and plunger 16 is disposed within loading tray 14 to provide lens positioning region 18. Figure 5B is a close-up view of lens positioning region 18 and distal portion 22 of plunger 16. As shown in Figure 5B, plunger 16 has been advanced within loading tray 14, wherein the engagement between tray channel wall portion 90 and keying features 32 prevents the plunger from rotating within the loading tray. Sidewalls 57 of the distal portion 22 of plunger are shown by the dotted lines. Lens contacting surface 51 and tab 54 have been advanced to a proximal region of lens positioning region 18 where tray channel wall portion 81 of loading tray 14 is wider than tray channel wall portions 80 or 90. The channel in loading tray 14 defined by wall portions 80, 81, and 90 allows for the implant to be positioned in lens positioning region 18 as well as for visual inspection of the lens during at least an initial portion of the loading process. The channel wall tapers from portion 81 to portion 80, which helps prevent the implant from being ejected from lens positioning region 18 as it is advanced towards the cartridge.

[0057] In an optional step, a lubricating material such as viscoelastic material is injected through the lumen of plunger (see Figure 2B) from the proximal end to the lens interfacing portion 22 to lubricate lens positioning region 18 in preparation for the positioning of the implant and to lubricate the implant and lens interfacing portion 22 for loading.

[0058] Figures 6A, 6B, and 6C (with increasing magnification) illustrate an exemplary manner of positioning an intraocular lens with the lens positioning region shown in Figures 5A and 5B. Lens 100 includes an optic portion 106 and a peripheral portion including first peripheral member 102 and second peripheral member 104. First peripheral member 102 is positioned such that it is in a leading position (at least a portion of it extends distally relative to optic 106), while second peripheral member 104 is in a trailing position (at least a portion of it

extends proximally relative to optic 106). Leading peripheral portion 102 includes a connection portion 108 (also referred to herein as a “buttress”) coupled to the optic portion, and haptic body portion 110 extending from connection portion 108. To load the lens into receiving area, haptic portion 110 is deformed relative to connection portion 108 from a position in which it follows the general curvature of optic 106 to the position shown in Figures 6A-6C (i.e., extending distally). This can be performed manually or using another tool. In the figures, haptic body portion 110 is disposed distal to connection portion 108, and engages an inner wall portion of loading tray. The distal portion 22 of plunger is not engaging leading peripheral member 102 in this embodiment. Trailing peripheral member 104 similarly includes a connection portion 112 (which may also be referred to herein as a “buttress”) and haptic body portion 114 extending from connection portion 112. The lens has been positioned into the lens positioning region so that lens engaging surface 53 is disposed relative to the optic portion so that surface 53 is positioned to apply a loading force on the optic portion, described below. Lens engaging surface 53 may or may not be in actual contact with optic portion 106, but if it is not it is very near to it and is considered “adjacent” to it. The intraocular lens has also been positioned in the lens positioning region so that lens engaging surface 51 is disposed relative to connection portion 112 so that lens engaging surface 51 can apply a loading force on the connection portion 112. Lens engaging surface 51 may or may not be in direct contact with connection portion 112, but if not it is very near to it and considered to be “adjacent.” Neither surface 51 nor 53 is positioned to apply a loading force to either of haptic body portions 110 or 114.

[0059] The lens has been positioned in the lens positioning region such that lens engaging surface 53 is distal to the trailing haptic. This allows the loading instrument to be actuated to apply loading forces to the optic (or other less flexible portions) while avoiding the trailing haptic body.

[0060] In this embodiment the connection portions 108 and 112 of each haptic are less flexible than haptic body portions 110 and 114. One advantage of the connection portions being stiffer than the body portions is to ensure that the haptics do not disengage from the optic portion, and to ensure that the connection portions do not fail at the connection point with the optic. It is therefore generally safer to apply loading forces to the less flexible connection portions rather than the body portions. In fact, in some instances applying loading forces to the haptic body portions can damage the haptic body portion. The optic, or at least the side of the optic (to which the loading forces are applied) is also less flexible than the haptic body portions, and thus can safely receive the loading force from lens engaging surface 53. Additionally, the loading force on optic 106 is applied to a side of optic rather than either the anterior or posterior optic surfaces. This helps ensure that damage is not done to the optic or its optical surfaces. In

this embodiment the lens is positioned so that the loading instrument can apply loading forces to the less flexible portions of the lens, while avoiding the application of loading forces to more flexible portions of the lens.

[0061] Tab 54 (not clearly shown) extends distally from protrusion 52 and provides sliding support for buttress 112 during the loading process. Lens contacting surface 51 of protrusion 50 is in contact with a portion of optic 106, as shown in the figures. Haptic portion 114 is folded proximally relative to buttress 112 between sidewall 57 and rib 55.

[0062] By positioning peripheral members 102 and 104 relative to optic 106, the manner in which the implant is compressed or deformed during the loading process can be controlled.

Additionally, when an intraocular lens comprises one or more fluids therein, controlling the manner in which fluid is redistributed within the lens during loading can be increasingly important to prevent rupturing of the lens.

[0063] After lens 100 is positioned within the lens receiving area as shown in Figures 6A-6C, an operator loads the intraocular lens into the cartridge. An operator advances the plunger distally within the loading tray, as illustrated in Figure 7. The actuation of the plunger causes loading forces to be applied to the side of optic 106 and connection portion 112 by lens engaging surfaces 53 and 51, respectively, as set forth above. It should be noted that some non-loading forces may be inherently applied to haptic body portion 114 from the wall of the distal end of plunger. These forces are not, however, considered loading forces as described herein. Because the lens engaging surfaces 51 and 53 apply forces to optic 106 and connection portion 112, and these forces drive the lens movement through the system, they are referred to as loading forces.

[0064] Actuation of plunger advances lens 100 within the loading tray and towards cartridge 12. The plunger, cartridge, and seals (see 28 and 30 in Figure 7) create a closed path for the lubricating agent from the proximal end of the plunger to the lens interfacing area. As the lens is advanced, the leading peripheral member first enters into cartridge, followed by the optic, and finally by the trailing peripheral member. The distal portion 22 of plunger helps introduce a preferential fold into the lens as it is advanced into cartridge. The lens folding is initiated by ramping and lumen section size restriction while the lens is being advanced. The tray dimensions also influence how the lens will fold. The lens folds generally along a fold axis, but the fold axis is not necessarily a perfectly straight line, and can be thought of as a fold axis along a general direction. Figure 9 illustrates exemplary folding axes A and B along which the lens from Figures 6A-7 may fold. With the system and lens shown, the lens folds generally along axis B, which extends generally through the center of the optic portion and divides the lens into generally symmetrical halves. The axis can also be somewhere in between axis A and axis B.

The folded configuration can be described generally, from an end-view of the lens, as a "C"

shape, a “U” shape, or a configuration in between. Exemplary intraocular lens described in U.S. Pub. No. 2008/0306588 can be loaded using the systems herein. For example, the lens can include an anterior element, a posterior element, and intermediate layer in between the anterior and posterior elements. In some embodiments the lens folds along the folding axis such that the posterior element forms the backside of the folded configuration, and the intermediate layer and anterior element are collapsed within the posterior element. In other embodiments, the posterior element and intermediate layer are collapsed within the anterior element. In some lenses the optic portion comprises one or more fluid channels in which fluid is adapted to move to actuate the lens. In some embodiments the lens can fold along those channels. In some embodiments axis B is in general alignment with the channels in the lens.

[0065] In some embodiments the lens does not have an intermediate layer and the optic portion comprises an anterior surface and a posterior surface defining an optic fluid-filled portion in fluid communication with the haptics. An exemplary lens of this type is described in U.S. Provisional Application No. 61/557,237, filed 11/8/2011, the disclosure of which is incorporated by reference. In these embodiments either the posterior element or the anterior element can form the backside of the folded configuration, collapsing the other element inside of it. In some embodiments of lens design not particularly disclosed herein, the lens can fold along axis A. The fold axis depends on the configuration of the peripheral portion of the lens, the optic configuration, how the peripheral portion is coupled to the peripheral portion, and other factors. Additionally, axis B as shown (along which the shown lens folds) is generally in alignment with the longitudinal axis of the loading tray, and the channel created in the loading tray.

[0066] During the loading of the lens into the cartridge, rib 55 provide axial stiffening and reduces the potential for base 56 to longitudinally buckle (see Figure 3). Base 56 provides axial stiffness while maintaining contact with the lens as the lens is folding during the loading process. The operator continues to advance the plunger (and therefore the lens) until substantially all of the lens is disposed within the cartridge. All of the lens can be advanced into proximal section 66 of cartridge (see Figure 4), or a portion of the lens (such as a portion of the leading haptic) can be disposed within intermediate portion 68. As the lens is moved into the cartridge, any fluid within the lens is redistributed, or at least the fluid pressure within portions of the lens changes. For example, as the optic portion is deformed, fluid in the optic can be moved towards the peripheral portion, or at least the fluid pressure in the peripheral portion increases. In other embodiments, as the leading haptic is advanced into the cartridge, the fluid is moved towards the optic, or at least the fluid pressure in the optic portion is increased. In other embodiments fluid moves from the trailing haptic towards the leading haptic by means of the pressure differential across the lens body.

[0067] Optionally, a lubricating syringe with plunger (not shown), engaged with the leu lock at the proximal end of plunger (see Figure 2B), is then actuated to advance the syringe plunger with respect to plunger 16 to advance a lubricating agent (such as a viscoelastic material) through plunger and into the cartridge to push the lens forward within the cartridge. This is continued until the leading haptic is disposed at the distal opening of the cartridge. This priming step is optional and is not necessarily performed. For example, in some embodiments the lens can be loaded and then delivered without the optional priming step. Avoiding the priming step in some uses may actually lessen the time that the lens body is in a relatively high compression state. This can potentially reduce time-dependent failures such as pressure-related material failures in the lens as well as sticktion issues between the lens and the cartridge.

[0068] At this point the lens can be stored in the cartridge for future implantation, or the lens can be delivered into the patient following the loading process into the cartridge. If it is to be stored, the cartridge can be released from the loading tray by disengaging the locking elements. When the lens is to be delivered, an incision is made in the patient's eye to allow for the distal tip of the cartridge to be positioned within the incision (the incision can be made at any point relative to the occurrence of any of the loading and delivery steps). The incision can be a scleral incision, and techniques for making a scleral incision are known. The incision is generally from about 3.8mm to about 5.5mm, and in some embodiments is about 4mm to about 5mm. In some embodiments the incision is about 4 mm, and in some embodiments the incision is about 5.2mm. To deliver the lens, the syringe plunger is again advanced (or if the priming step above is not performed, the syringe plunger is advanced for the first time) to push viscoelastic material through the cartridge, forcing the implant from the distal port of the cartridge and into the target location within the eye. Varying the cartridge material and fluid delivery velocity allows for a variety of fluids to be used to deliver the lens from the cartridge. For example, using a given combination of cartridge material and fluid velocity, a low viscosity fluid such as saline can be used to deliver the lens from the cartridge.

[0069] In this way the viscoelastic material is all that is needed to force the lens from the cartridge into the eye (although other forces could be used). The leading haptic is delivered first, followed by the optic, and then the trailing haptic. In some embodiments the lens is delivered into a native capsule from which the native lens has been removed. In some embodiments the lens is delivered outside the native capsule from which the native lens has been removed. In some embodiments the lens can be delivered into the anterior chamber.

[0070] One aspect of the disclosure is a method of deploying a fluid-filled intraocular lens from a delivery device, comprising applying a loading force on an optic portion of a fluid-filled

intraocular lens to load the intraocular lens into a cartridge, and advancing the intraocular lens through the cartridge solely by delivering a fluid (e.g., viscoelastic) through the cartridge.

[0071] An additional advantage of the loading systems described herein is that the orientation of the lens relative to the anatomy of the eye can be controlled during loading and/or delivery. In Figures 6A-7, an anterior surface of the optic is shown “facing up” in the figures. The posterior surface is facing down, and cannot be seen in the figures. When loaded anterior-up, it will be delivered from the system in the same orientation – anterior-up, and will not roll as it is being advanced through the cartridge. This gives the operator confidence that they will know the orientation of the lens as it is deployed. This can be important because the operator (e.g., a surgeon) generally wants to deliver an intraocular lens into the eye in a known orientation relative to the rest of the eye. For example, when an intraocular lens is being delivered within a native capsule, for which the native lens has been removed, the operator may want to deliver the intraocular lens such that anterior surface of the intraocular lens faces in the anterior direction and the posterior surface of the intraocular lens faces in the posterior direction. Stated alternatively, it may be beneficial to deliver the intraocular lens substantially in the same plane as the capsular bag.

[0072] Even when an intraocular lens does not have dedicated anterior and posterior surfaces (i.e., either surface can be delivered facing in the anterior direction and either surface can be delivered facing in the posterior direction), the systems herein still provide the advantage that the anterior and posterior surfaces of the lens will be delivered in substantial alignment with the plane of the capsular bag, and that the lens will not undergo substantial “roll” as it is advanced through the loading system. This can still provide the advantage that the operator knows the overall relative orientation of the lens as it is delivered. Again the operator will know that they do not have to rotate the system in order to deliver the lens in a desired orientation.

[0073] Figure 8 illustrates loading tray 14 and plunger 16 when plunger is advanced such that the plunger lens interfacing portion is in the distal portion of loading tray 14. Detent 25 (see Figure 2A) interacts with loading tray to prevent relative movement between tray 14 and plunger 16.

[0074] It should be noted that not all of the method steps described in the exemplary method of loading and delivery need to be performed. For example, the lens could be delivered from the cartridge by first disengaging the tray from the cartridge, then advancing a small plunger through the cartridge to deliver the lens from the cartridge.

[0075] Additionally, lenses can be loaded using the systems described herein even if their peripheral portions do not have the same shape and/or configurations as described herein, if the loading of such lenses can be improved by using the systems herein. Additionally, a lens can

have more or less than two peripheral members and still be loaded and delivered using the systems herein. For example, a lens could have only one peripheral portion and could be loaded as the trailing peripheral portion. In this exemplary embodiment there would be no leading peripheral member, simply the optic portion and the trailing haptic. Or, alternatively, a lens
5 could be delivered with more than two peripheral portions as long as the third (or more) peripheral portions do not interfere with the loading.

CLAIMS

WHAT IS CLAIMED IS:

- 5 1. A method of loading a fluid-filled intraocular lens into a delivery or storage device, comprising:
providing a fluid-filled intraocular lens comprising an optic portion and a peripheral portion;
applying loading forces with a loading instrument on the optic portion and on a first
10 portion of the peripheral portion that is less flexible than a second portion of the peripheral portion, wherein the method of loading does not apply a loading force on the second portion of the peripheral portion; and
loading the intraocular lens into a delivery or storage device using the loading instrument.
- 15 2. The method of claim 1 wherein applying the loading forces comprises applying a loading force to the optic portion with a first surface of the loading instrument and applying a loading force to the first portion of the peripheral portion with a second surface of the loading instrument.
- 20 3. The method of claim 2 wherein the first surface is distal to the second surface.
4. The method of claim 2 wherein the first surface is on a first side of the loading instrument and the second surface is on a second side of the loading instrument.
- 25 5. The method of claim 1 wherein applying loading forces comprises applying generally distally directed forces on a side of the optic portion and on the first portion of the peripheral portion.
6. The method of claim 1 wherein loading comprises deforming at least a portion of the
30 lens.
7. The method of claim 1 wherein the peripheral portion is in fluid communication with the optic portion, and wherein the first portion of the peripheral portion is coupled to the optic portion and the second portion of the peripheral portion extends from the first portion.

8. The method of claim 1 further comprising positioning the intraocular lens in a lens receiving area created by a loading instrument distal region and a loading tray such that a first haptic extends distally relative to the optic portion and a trailing haptic extends proximally relative to the optic portion, wherein the first portion of the peripheral portion is a buttress of the first haptic and the second portion extends from the buttress and is adapted to engage a capsular bag.
9. The method of claim 1 further comprising positioning a loading instrument distal portion relative to a loading tray so that the loading instrument distal portion and the loading tray create an intraocular lens positioning region, and positioning the intraocular lens in the lens positioning region prior to applying the loading forces.
10. A method of loading a fluid-filled intraocular lens into a delivery or storage device, comprising:
- providing a fluid-filled intraocular lens comprising an optic portion and a first haptic, the first haptic comprising a connection portion coupled to the optic portion and a second portion extending from the connection portion;
- applying a loading force with a loading instrument on the optic portion and on the connection portion of the first haptic without applying a loading force on the second portion of the first haptic; and
- loading the intraocular lens into a delivery or storage device.
11. The method of claim 10 further comprising positioning the fluid-filled intraocular lens in a lens positioning area of a loading device.
12. The method of claim 10 wherein applying the loading forces comprises applying a loading force on the optic portion with a first surface of the loading instrument and applying a loading force on the connection portion with a second surface of the loading instrument.
13. The method of claim 12 wherein the first surface is distal to the second surface.
14. The method of claim 12 wherein the first surface is on a first side of the loading instrument and the second surface is on a second side of the loading instrument.
15. The method of claim 10 wherein applying loading forces comprises applying generally distally directed forces on the optic portion and the connection portion.

16. The method of claim 10 wherein loading comprises deforming at least a portion of the lens.

5 17. The method of claim 10 further comprising positioning the intraocular lens in a lens positioning area created by a loading instrument distal region and a loading tray such that the first haptic extends proximally relative to the optic portion and a leading haptic extends distally relative to the optic portion.

10 18. A method of preparing a fluid-filled intraocular lens for deformation into a delivery or storage device:

positioning a plunger distal portion relative to a loading tray so that the plunger distal portion and the loading tray create an intraocular lens positioning region; and

15 positioning an intraocular lens in the lens positioning region so that a lens engaging surface of the plunger distal portion is disposed relative to the fluid-filled optic portion so that the lens engaging surface is positioned to apply a loading force on the fluid-filled optic portion.

19. The method of claim 18 wherein positioning the intraocular lens comprises positioning the intraocular lens so that the lens engaging surface of the plunger distal portion is positioned
20 distal to a trailing haptic of the intraocular lens.

20. The method of claim 18 wherein positioning the intraocular lens comprises positioning the intraocular lens so that a second lens engaging surface of the plunger is disposed relative to a haptic connection portion of the intraocular lens so that the second lens engaging surface is
25 adapted to apply a loading force on the haptic connection portion.

21. The method of claim 18 wherein positioning the intraocular lens comprises positioning the intraocular lens so that a trailing haptic extends proximally from the optic portion.

30 22. The method of claim 21 wherein positioning the intraocular lens comprises positioning the intraocular lens so that the lens engaging surface of the plunger distal portion is positioned distal to the trailing haptic of the intraocular lens.

23. The method of claim 21 wherein positioning the intraocular lens comprises positioning
35 the intraocular lens so that a leading haptic extends distally from the optic portion.

24. The method of claim 18 wherein positioning the intraocular lens comprises positioning the intraocular lens so that a second lens engaging surface of the plunger distal portion is disposed relative to a haptic connection portion so that the second lens engaging surface is adapted to apply a loading force on the haptic connection portion without applying a loading force on a haptic body portion that extends from the haptic connection portion.

25. The method of claim 24 wherein the lens engaging surface is disposed distal relative to the second lens engaging surface.

10

26. A method of preparing a fluid-filled intraocular lens for deformation into a delivery or storage device, comprising:

positioning a plunger distal portion relative to a loading tray so that the plunger distal portion and the loading tray create an intraocular lens positioning region; and

15 positioning an intraocular lens in the lens positioning region so that a first lens engaging surface of the plunger distal portion is disposed relative to a fluid-filled optic portion of the intraocular lens so that it can apply a loading force on the fluid-filled optic portion, and so that a second lens engaging surface of the plunger is disposed relative to a peripheral portion of the intraocular lens so that it can apply a loading force on the peripheral portion of the intraocular lens.

20

27. The method of claim 26 wherein positioning the intraocular lens comprises positioning the intraocular lens so that the first lens engaging surface of the plunger distal portion is positioned distal to a trailing haptic of the intraocular lens.

25

28. The method of claim 26 wherein positioning the intraocular lens comprises positioning the intraocular lens so that the second lens engaging surface of the plunger is disposed relative to a haptic connection portion of the intraocular lens so that the it can apply a loading force on the haptic connection portion.

30

29. The method of claim 26 wherein positioning the intraocular lens comprises positioning the intraocular lens so that a trailing haptic extends proximally from the optic portion.

30. The method of claim 29 wherein positioning the intraocular lens comprises positioning the intraocular lens so that the first lens engaging surface of the plunger distal portion is positioned distal to the trailing haptic of the intraocular lens.

5 31. The method of claim 29 wherein positioning the intraocular lens comprises positioning the intraocular lens so that a leading haptic extends distally from the optic portion.

32. The method of claim 26 wherein the first lens engaging surface is disposed distal relative to the second lens engaging surface.

10 33. A method of deploying a fluid-filled intraocular lens from a delivery device, comprising:
applying a loading force on an optic portion of a fluid-filled intraocular lens to load the intraocular lens into a cartridge; and
advancing the intraocular lens out of the cartridge solely by delivering a fluid through the cartridge.

15

34. The method of claim 33 further comprising applying a loading force on a first portion of a peripheral portion of the intraocular lens that is less flexible than a second portion of the peripheral portion of the intraocular lens.

20 35. The method of claim 34 further comprising applying a loading force on a haptic connection portion that is less flexible than a haptic body portion without applying a loading force on the haptic body portion.

25 36. A loading instrument adapted to advance an intraocular lens through a loading device, comprising:

an elongate portion and a distal lens engaging portion extending distally from the elongate portion,

the distal lens engaging portion comprising a first lens engaging surface adapted to engage an optic portion and a second lens engaging surface adapted to engage a peripheral
30 portion of the intraocular lens.

37. The loading instrument of claim 36 wherein the first lens engaging surface is positioned distal to the second lens engaging surface.

38. The loading instrument of claim 36 wherein the first lens engaging surface is disposed on a first side of the loading instrument and the second lens engaging surface is disposed on a second side of the loading instrument.

5 39. The loading instrument of claim 36 wherein the distal lens engaging portion comprises a generally flat base portion, and wherein the first and second lens engaging surfaces extend from the base portion.

40. The loading instrument of claim 39 wherein the base portion is substantially perpendicular to the first and second lens engaging surfaces.

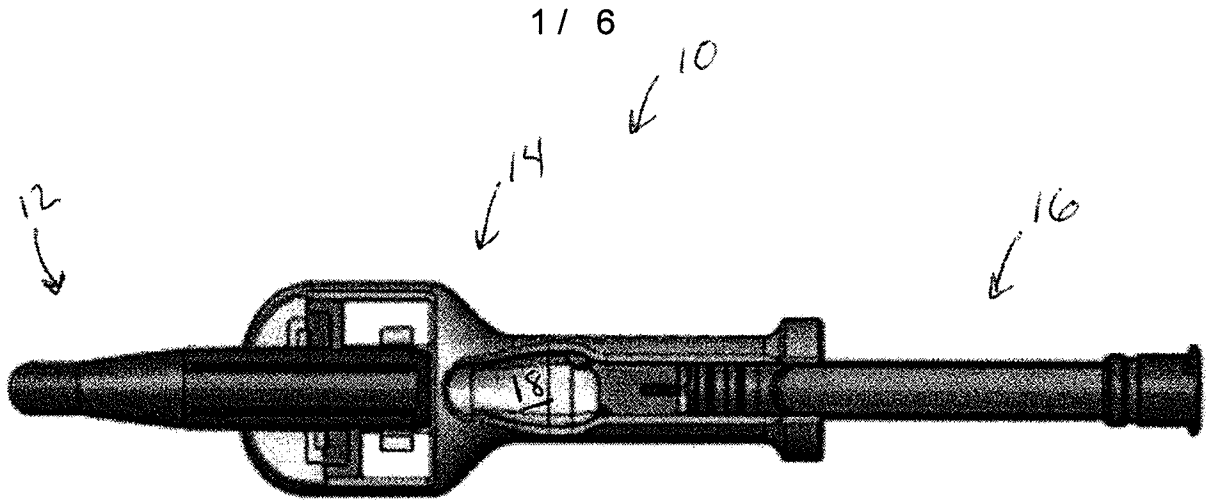

FIG. 1

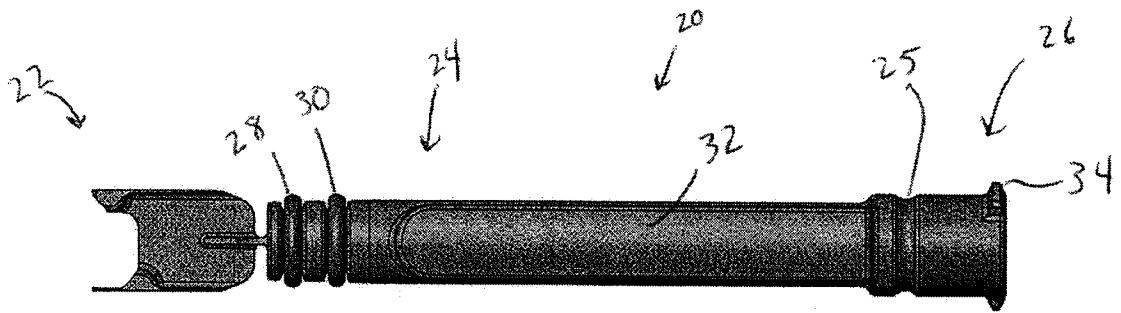

FIG. 2A

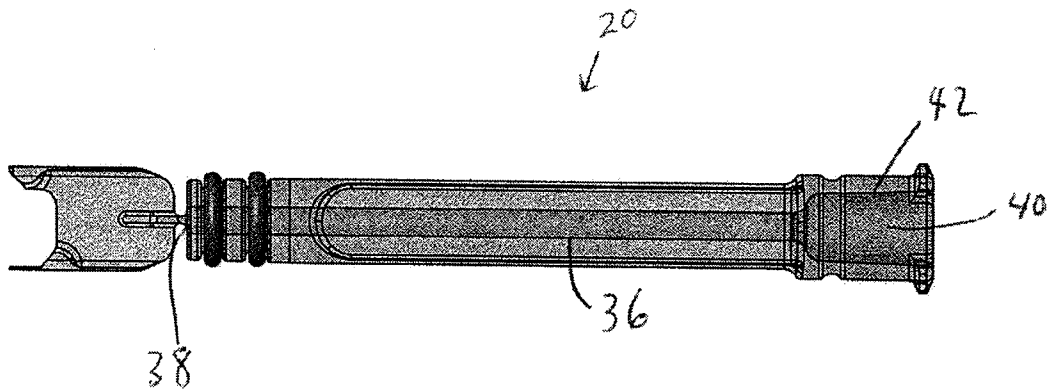

FIG. 2B

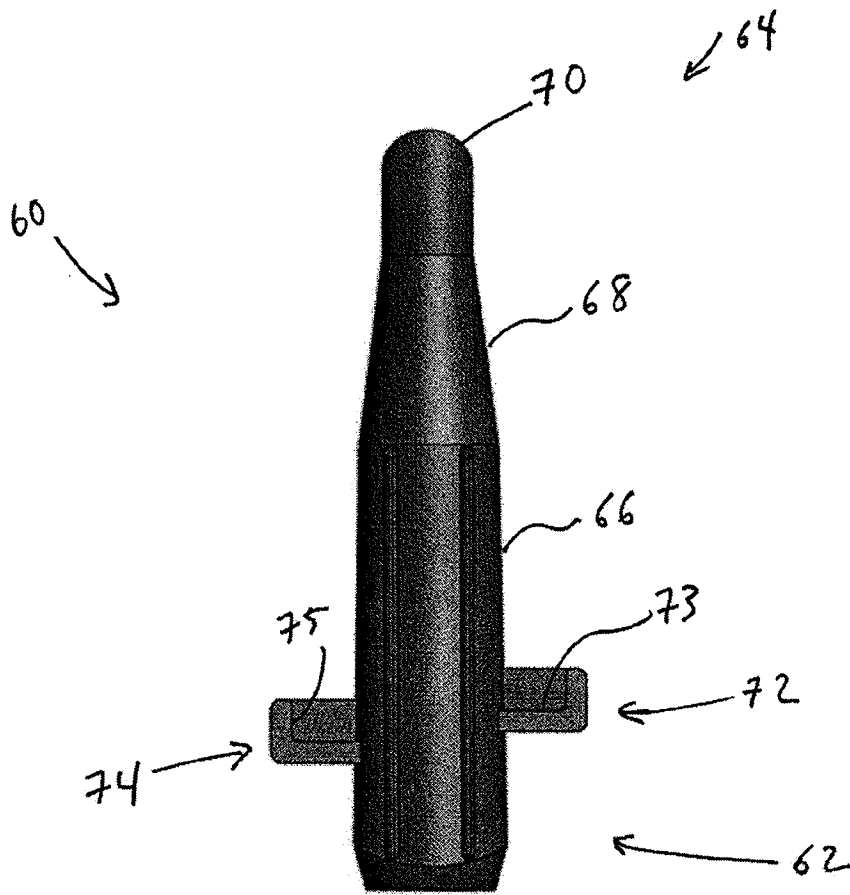
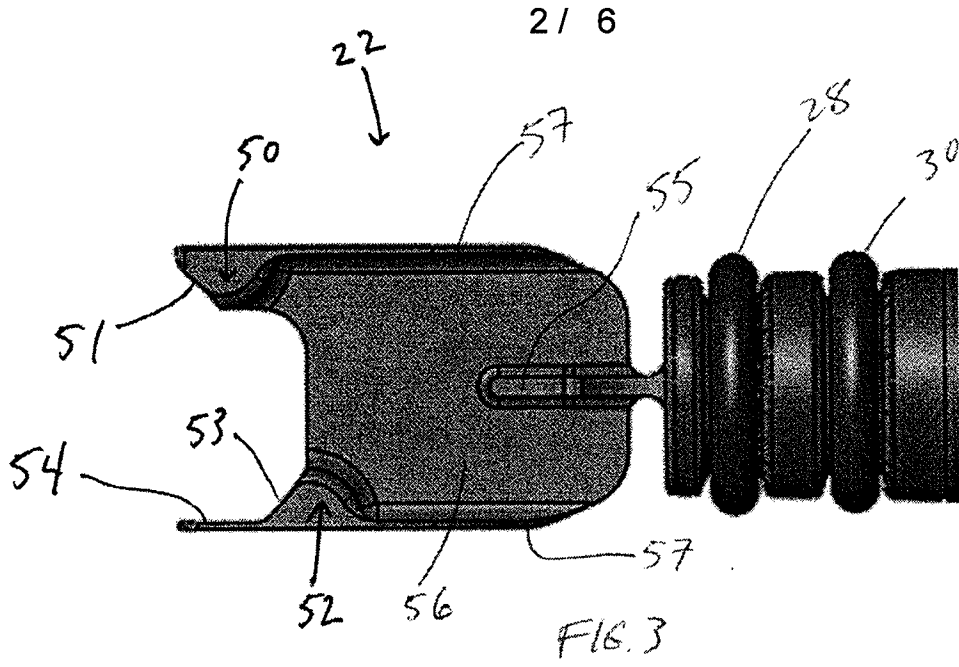

FIG. 4

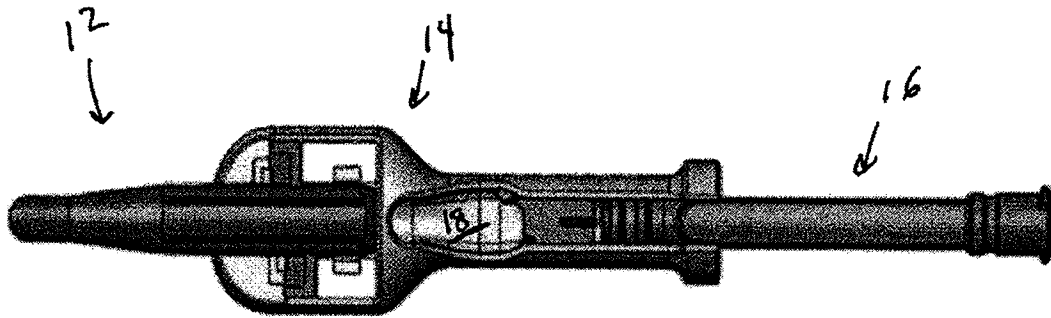

FIG. 5A

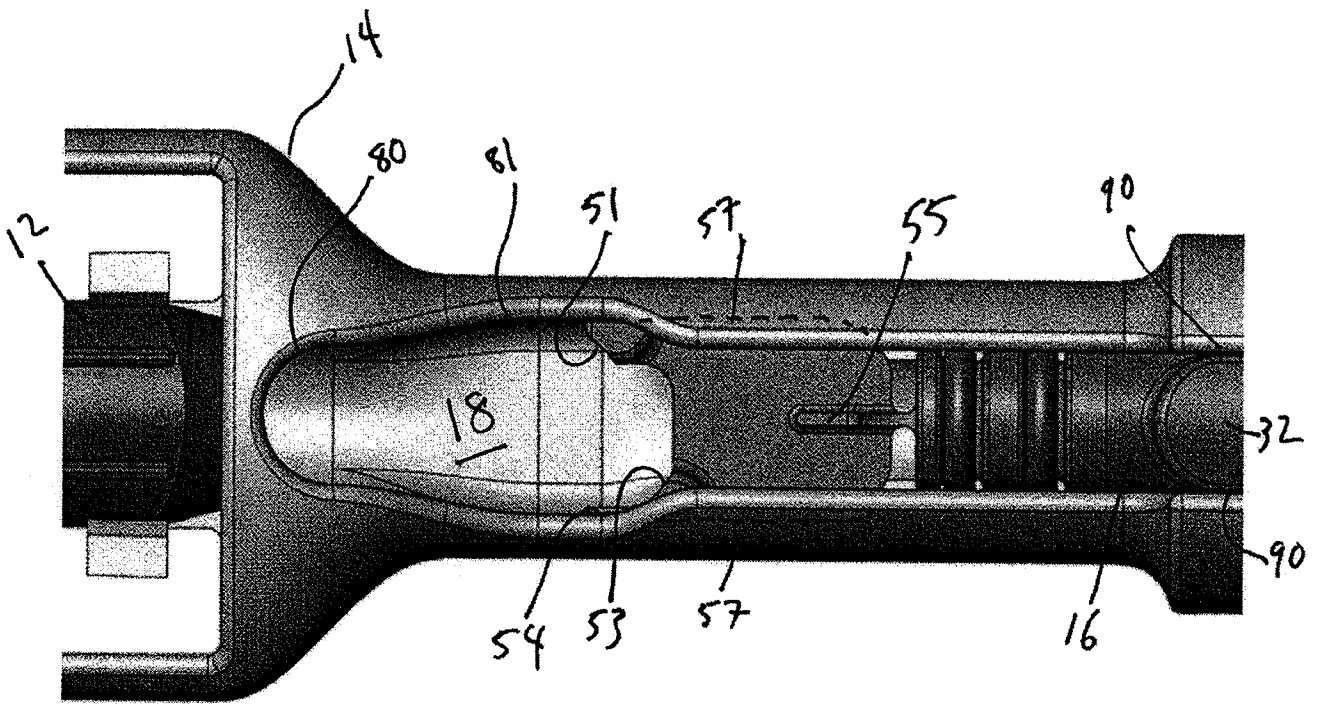
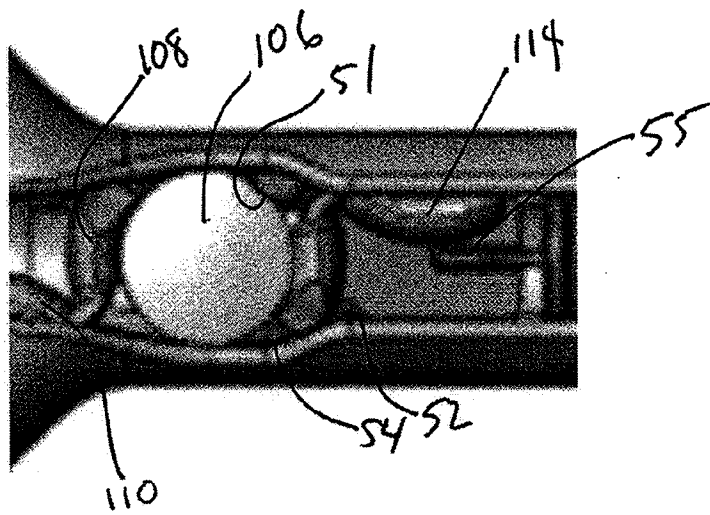
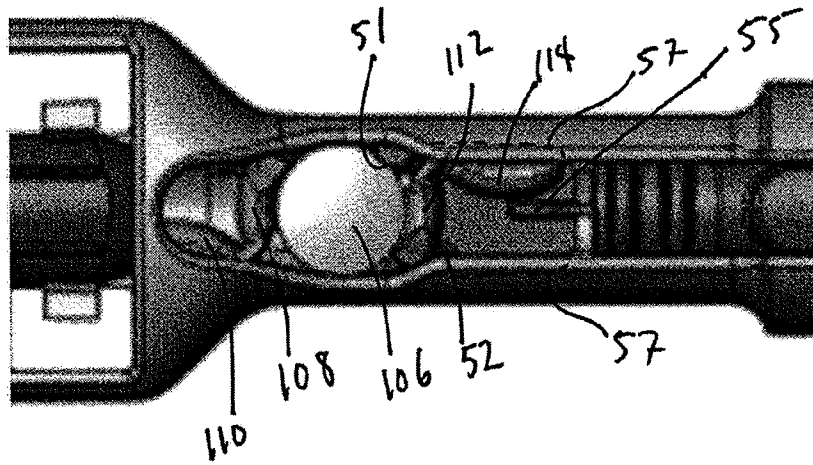
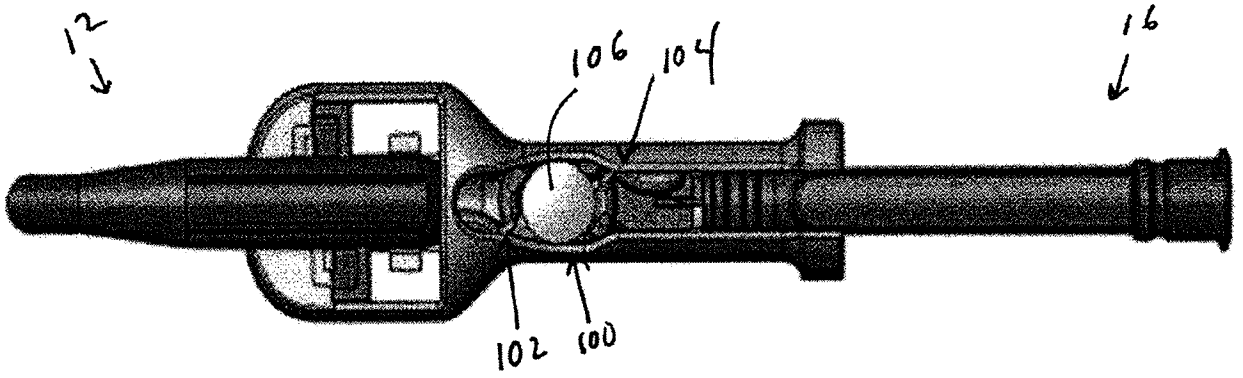
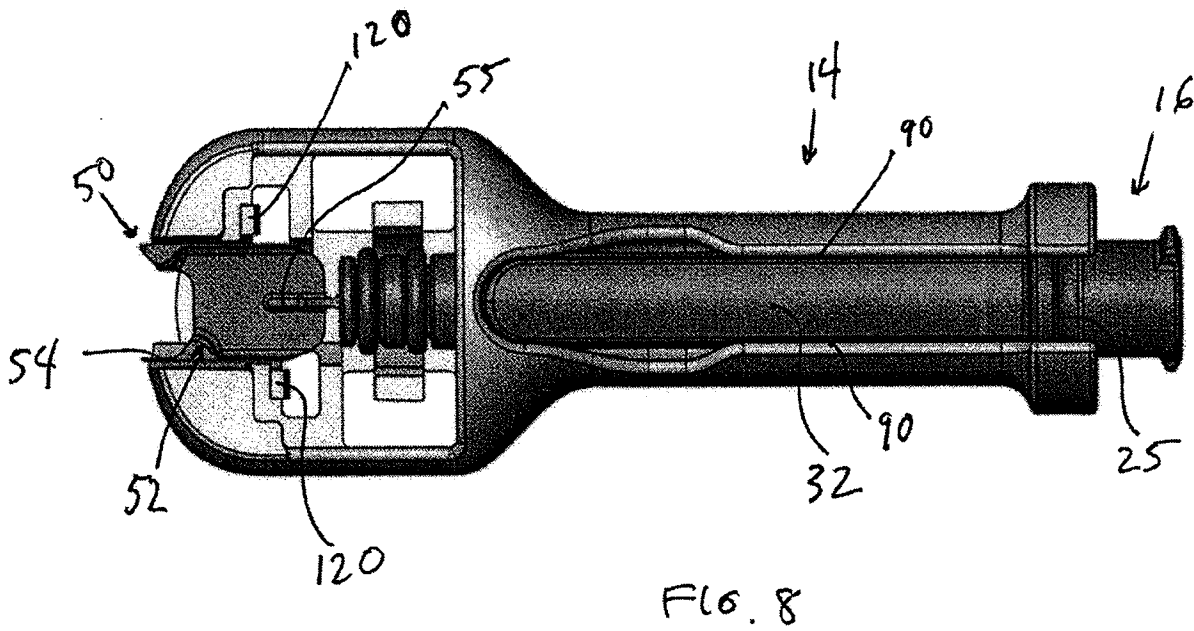
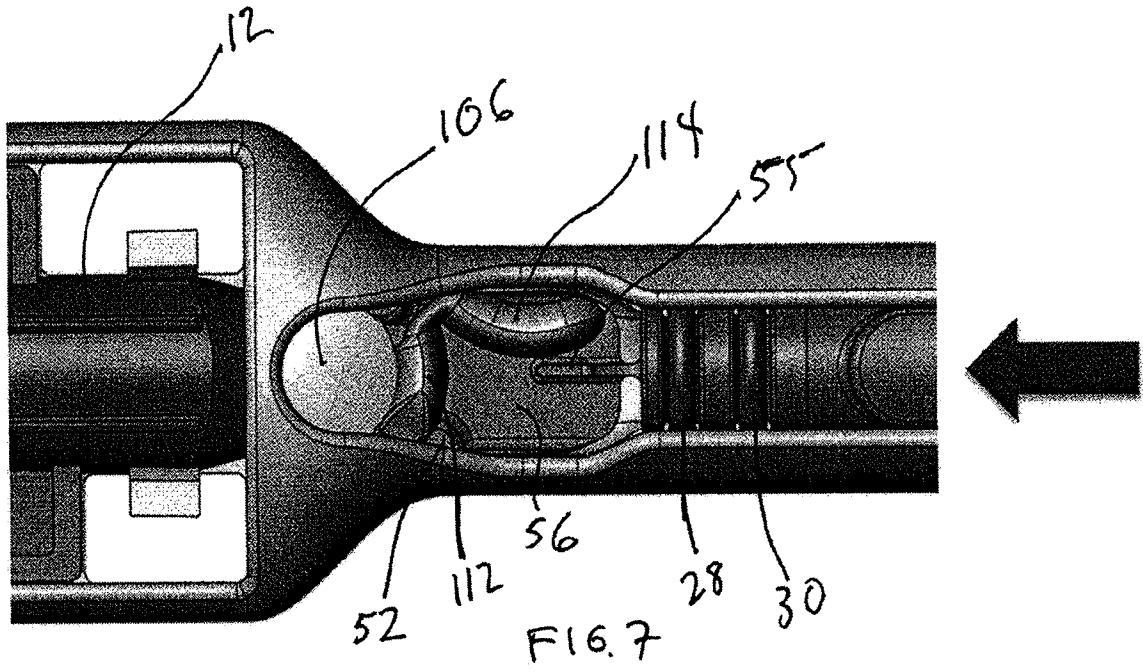

FIG. 5B





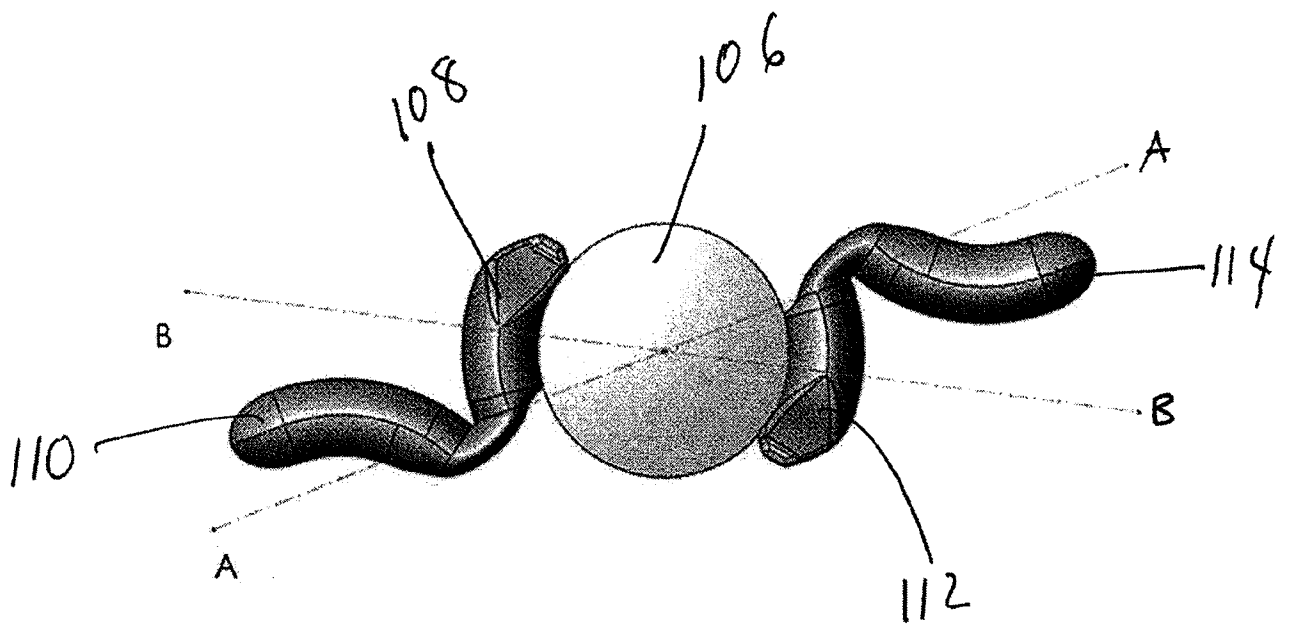

FIG. 9