

REPUBLIC OF SOUTH AFRICA
PATENTS ACT, 1978**PUBLICATION PARTICULARS AND ABSTRACT**

(Section 32(3)(a) – Regulation 22(1)(g) and 31)

OFFICIAL APPLICATION NO.

LODGING DATE

ACCEPTANCE DATE

21 01 2006/04179

22 29 NOV 2004

43 27-11-2007

INTERNATIONAL CLASSIFICATION

NOT FOR PUBLICATION

51 E21B

CLASSIFIED BY: WIPO

FULL NAMES OF APPLICANT

71 ATLAS COPCO ROCK DRILLS AB

FULL NAMES OF INVENTORS

72 1. HARTWIG, SVERKER
2. HENRYSSON, JONAS

EARLIEST PRIORITY CLAIMED

COUNTRY

NUMBER

DATE

33 SE

31 0303548-2

32 29 DEC 2003

TITLE OF INVENTION

54 METHOD AND SYSTEM FOR CONTROLLING POWER CONSUMPTION DURING A ROCK DRILLING PROCESS AND A ROCK DRILLING APPARATUS THEREFORE

57 ABSTRACT (NOT MORE THAT 150 WORDS)

NUMBER OF SHEETS 27

If no classification is finished, Form P.9 should accompany this form.
The figure of the drawing to which the abstract refers is attached.

**METHOD AND SYSTEM FOR CONTROLLING POWER CONSUMPTION DURING A
ROCK DRILLING PROCESS AND A ROCK DRILLING APPARATUS THEREFORE**

Field of the invention

The invention relates to a method for controlling power
5 consumption during a rock drilling process of the kind defined
in the preamble of claim 1.

The invention further relates to a system and a rock drilling
apparatus of the kind defined in the preamble of claims 11 and
10 21, respectively.

Background of the invention

Rock drilling apparatuses may be used in a number of fields.
For example, rock drilling apparatuses may be used in
15 tunnelling, underground mining, rock reinforcement, raise
boring, and for drilling of blast holes, grout holes and holes
for installing rock bolts.

Rock drilling is often performed by percussion rock drilling,
20 in which a drill tool mounted at one end of a drill rod is
provided with impact pulses by a hammer piston, arranged on
the opposite side of the drill rod, and arranged to be powered
to repeatedly impact upon the drill rod. At the outermost end
of the drill tool there are drill bits that penetrate the rock
25 and break it upon the impacts by the hammer piston.

The drill tool also may be pressed against the rock to
maintain contact between the tool and the rock in order to
make sure that as much impact energy as possible from the
30 hammer piston is transmitted to the rock. To make the drilling
process more efficient the drill tool may further be rotated
somewhat between the impacts so that the drill bits hit a new

location at every impact. The drill cuttings are flushed away from the hole with a suitable medium. This medium usually is air in surface drilling apparatuses, water in underground working apparatuses. Alternatively, watermist with or without a chemical additive may be used in both types of apparatuses.

The rock drilling apparatus further comprises main power supply means, such as a diesel engine that is used to produce power for power requiring functions of the rock drilling apparatus. These functions may include a compressor for producing flushing pressure/flow, percussion power, rotational power, feeding power, feeding rate, hydraulic pumps, cooling fans.

Rock drilling may further be carried out by apparatuses utilising only rotation and applied pressure to break the rock, or apparatuses only utilising rotation to break the rock.

The main power supply means is dimensioned such that all functions may be used using their maximum output power rate simultaneously at all times to ensure proper function.

A problem with existing rock drilling equipment, however, is that they often consume more power than necessary during a drilling process, which results in excessive fuel consumption, and heat and noise generation.

Accordingly, there is a need for an improved rock drilling method that addresses the above mentioned problem.

Summary of the invention

It is an object of the present invention to provide a method for controlling power consumption during a rock drilling process that addresses the above mentioned problem. This object is achieved by a method for controlling power consumption during a rock drilling process according to the characterising portion of claim 1.

Another object of the present invention is to provide a system for controlling power consumption during a rock drilling process, which addresses the above mentioned problem. This object is achieved by a system as defined in the characterising portion of claim 11.

It is a further object of the present invention to provide a rock drilling apparatus that addresses the above mentioned problem. This object is achieved by a rock drilling apparatus according to claim 21.

The method for controlling power consumption during a rock drilling process with a rock drilling apparatus, includes adjusting the flush power at least partly as a function of hole depth, and controlling at least the percussion power and/or rotational power and the flush power such that the total power consumption of each sub-process is controlled such that the power output from the main power supply means is kept at or below a predetermined level.

This has the advantage that only the required amount of power at a certain hole depth is used for flushing, and that the remaining power may be used for other functions and/or for saving power, resulting in for example less fuel consumption, less noise and less heat.

The flush power may further be adjusted at least partly as a function of hole diameter and/or diameter of the drill rod.

The flow of the flush medium may be kept substantially constant throughout the drilling process, i.e. the flush power
5 increases with increased hole depth. The hole depth may further be continuously measured. This has the advantage that the flow may be kept at precisely the flow level needed for managing to flush the drill hole, and thus the flush power may kept at lowest possible value throughout the drilling process,
10 at all times.

The flow of the flush medium may be increased at least slightly with increasing hole depth. This has the advantage that as the hole depth increases, the flow may be increased somewhat in order to further compensate for the hole depth
15 and/or drill rod joints and/or drill cuttings tending to get stuck on the wall of the drill hole.

The required flush power may be determined by computer means. The computer means may be connected to a memory in which is stored a table comprising one or more of lists of types of
20 drill tools and/or types of drill rods, and preferably calculation parameters to be used with a selected combination. The flush power may be determined based on stored data concerning type of drill tool and/or type of drill rod and/or hole depth. This has the advantage that the flow of the flush
25 medium may be kept at a desired value independent of for example which drill tool diameter and/or drill rod diameter that is used.

The invention may be used in conventional rock drilling apparatuses, for example in apparatuses utilising percussion
30 or rotation or a combination thereof.

Brief description of the drawings

Fig. 1 shows an exemplary embodiment of a rock drilling apparatus according to the present invention.

Fig. 2 shows a block diagram describing an exemplary
5 embodiment of the present invention.

Detailed description of preferred embodiments

Fig. 1 depicts an exemplary rock drilling apparatus according to the present invention. In the figure is shown a rock drilling apparatus 1, in this exemplary a surface drill rig.
10 The drill rig 1 is shown in use drilling a hole 2, starting from a ground level, at present having reached a depth α and destined to result in a hole of depth β , for example 30 meters, the finished hole being indicated by interrupted lines. (The shown relation of drill rig height/hole depth is
15 not intended to be exact. The total height γ of the drill might for example be 10 meters.)

The drill rig 1 is provided with a top hammer 11 mounted via a rock drill cradle 13 on a feed 5. The feed 5 is attached to a boom 15 via a feed holder 12. The top hammer 11 provides
20 percussive action to a drill tool 3 with one or more drill bits 4 via a drill rod 6 supported by a rod support 14. The top hammer 11 is power supplied from a hydraulic pump 10, driven by a diesel engine 9, via a conduit attached to the feed 5 (the hydraulic feed is not shown in the figure). The
25 drill cuttings are flushed out of the hole 2 by compressed air that is fed through a tube, preferably in the center of the drill rod 6, and is discharged near the drill tool 3. The compressed air flushes the drill cuttings upwards through and out of the hole 2, as indicated by the upwardly directed
30 arrows in fig 1. Instead of compressed air, other flushing media may be used as well, for example watermist with or

without a chemical additive. The compressed air is fed to the drill rod 6 from a compressor 8 via a tube 7. The compressor 8, in turn is powered by the diesel engine 9.

5 In current drill rigs the diesel engine 9 has to be large enough to be able to simultaneously drive both the compressor and the hydraulic pump at full rate as well as cooling fans and other appliances. The compressor is always driven at or near its maximum rate during drilling, and since the
10 compressor may consume for example 120 hp of a diesels total output of for example 300 hp, the compressor consumes a large amount of fuel, which results in the generation of large amounts of exhaust gases and of noise and heat, which further results in even more noise and fuel consumption due to the fact that cooling fans need to be driven harder.

15 According to the present invention, however, these drawbacks may be reduced by driving the compressor at the power level that is currently required. For example, at the beginning of the drilling of a hole, the flush power that is required to produce a flow of the flush medium being sufficient to
20 evacuate the drill cuttings is relatively small, and thus the compressor need not deliver more than this required power. This means that the diesel engine in turn can be driven with reduced power output, thus resulting in decreased fuel consumption, less generated heat and less generated noise.
25 Alternatively, the power thus saved by driving the compressor with reduced input power may be used to allow more power to be allocated to the top hammer than otherwise is possible, which results in faster drilling in the first and/or most part of the hole.

30 The compressor power reduction may be accomplished in different ways depending on compressor type. In case of for

example a displacement compressor, the power may be reduced by either reducing the R.P.M. or unloading the compressor by shutting the inlet.

5 The control of the compressor power will now be described with reference to fig. 2, showing a block diagram of a control system. The figure shows a drill rig 21 with a diesel engine 22. The diesel engine is directly or indirectly connected to a compressor 23, a hydraulic pump 29, cooling fan(s) 24, other appliance(s) 25, a top hammer 26 and a controller 27, such as
10 a computer. The controller is further connected to the compressor 23 and/or the hydraulic pump and/or the cooling fans(s) 24 and/or of the appliances 25.

In order to control the compressor power, a sensor 28, for example mounted on the feed, provides the controller 27 with
15 information regarding the current hole depth, and the controller 27 then transmits, for example via a CAN bus, control signals to the compressor 23 including information about which power/pressure it should deliver in order to produce a desired flow of the flush medium. The controller may
20 further send control signals to the diesel engine and/or cooling fans(s) and/or other appliances as needed, for example desired power values. The controller 27 may include a memory 30 in or connected to it, in which is stored desired values for the compressor settings versus hole depths so that the
25 compressor may be correctly adjusted. Alternatively or in addition, there may further be stored calculation parameters to be used with the hole depth to calculate a desired compressor power. These calculation parameters may be dependent on type of drill tool and/or type of drill rod.
30 Preferably calculation parameters are stored for each possible combination of drill tool and/or drill rod. In an alternative embodiment there are listings stored in the memory, wherein

each listing includes compressor settings versus depth for each combination. For example, there may be values stored for each cm or dm or m increased hole depth. It is also possible to store values resulting in an increasing flow as the hole
5 depth increases in order to compensate for the factors mentioned above.

In a further exemplary embodiment (not shown), a sensor sensing the actual flow may be connected to the controller, which enables the controller to continuously send control
10 signals to the compressor based on the flow values. The flow may for example be calculated as litres per revolution of the compressor * revolutions per minute (R.P.M) * working time/total time.

The desired flow may in an alternative exemplary embodiment be
15 set by the operator by setting a value on a control or by inputting a desired value to the controller via a man machine interface such as a display and/or a keyboard.

The present invention has for example the advantage that when
20 drilling narrow holes, the compressor need not be working at full power at all during the drilling process, thus resulting in a fuel save and/or extra power for the top hammer throughout the drilling process.

In the above description, the invention has been described in connection with a surface drill rig with a hydraulic top
25 hammer drill rig. The present invention may, however, equally well be used with any other type of drilling apparatus with separately powered flushing and drilling. For example, the invention may be used with rock drilling apparatuses utilising both percussion and rotation to perform the rock drilling. The
30 invention may also be used in rock drilling where only rotation and applied pressure is utilised to break the rock,

or where only rotation is used, which for example might be the case in soft rock drilling, such as in coal mines. In the cases where rotation is used to break the rock, the power saved from reduced flushing may be utilised for faster rotation and thereby faster drilling.

It should further be understood that numerous other sensors, for example temperature sensors, may be connected to the controller in order to provide it with information useful in controlling the operation of the rock drilling apparatus.

Claims

1. A method for controlling power consumption during a rock drilling process with a rock drilling apparatus, wherein the rock drilling apparatus includes main power supply means for supplying power for the rock drilling process, which includes at least the sub-processes of percussion and/or rotation and flushing, the method comprising the steps of:
- adjusting the flush power at least partly as a function of hole depth, and
 - controlling at least the percussion power and/or rotational power and the flush power such that the total power consumption of each sub-process is controlled.
2. Method according to claim 1, **characterised in** that the flush power further is adjusted at least partly as a function of hole diameter and/or diameter of the drill rod.
3. Method according to claim 1 or 2, **characterised in** that the total power consumption of each sub-process is controlled such that the power output from the main power supply means is kept at or below a predetermined level.
4. Method according to any of the claims 1-3, **characterised in** that the flow of the flush medium is kept substantially constant throughout the drilling process.
5. Method according to any of the claims 1-3, **characterised in** that the flow of the flush medium is increased with increasing hole depth.
6. Method according to any of the claims 1-5, **characterised in** that the hole depth is continuously measured.

7. Method according to any of the claims 1-6, **characterised in** that the flow of the flush medium is continuously measured.

5 8. Method according to any of the claims 1-7, **characterised in** that the required flush power is determined by computer means.

9. Method according to claim 8, **characterised in** that the computer means is connected to a memory in which is stored a
10 table comprising one or more lists at least partly including type of drill tool and/or type of drill rod and/or hole depth and that the flush power is determined based on stored values.

10. Method according to any of the claims 1-9, **characterised**
15 **in** that percussion is performed by a hydraulic top hammer.

11. System for controlling power consumption during a rock drilling process with a rock drilling apparatus, wherein the rock drilling apparatus includes main power supply means for supplying power for the rock drilling process, which includes
20 at least the sub-processes of percussion and/or rotation and flushing, the system comprising:
- means for adjusting the flush power at least partly as a function of hole depth, and
- means for controlling at least the percussion power and/or
25 rotational power and the flush power such that the total power consumption of each sub-process is controlled.

12. System according to claim 11, **characterised in** that it further includes means for adjusting the flush power at least
30 partly as a function of hole diameter and/or diameter of the drill rod.

13. System according to claim 11 or 12, **characterised in** that the system is arranged to control the total power consumption of each sub-process such that the power output from the main power supply means is kept at or below a predetermined level.

5

14. System according to any of the claims 11-13, **characterised in** that the system is arranged to keep the flow of the flush medium substantially constant throughout the drilling process.

10

15. System according to any of the claims 11-13, **characterised in** that the system is arranged to increase the flow of the flush medium with increasing hole depth.

15

16. System according to any of the claims 11-15, **characterised in** that the system is arranged to continuously measure the hole depth.

20

17. System according to any of the claims 11-16, **characterised in** that the system is arranged to continuously measure the flow of the flush medium.

25

18. System according to any of the claims 11-17, **characterised in** that the system is arranged to determine the required flush power by computer means.

0

19. System according to claim 18, **characterised in** that the computer means is connected to a memory arranged to store a table comprising one or more of lists at least partly including type of drill tool and/or type of drill rod and/or hole depth, and that the flush power is arranged to be determined based on stored values.

20. System according to any of the claims 11-19, **characterised in** that percussion is arranged to be performed by a hydraulic top hammer.

21. Rock drill apparatus, **characterised in** that it is arranged to include a system according to any of the claims 11-20.

1/2

Fig. 1

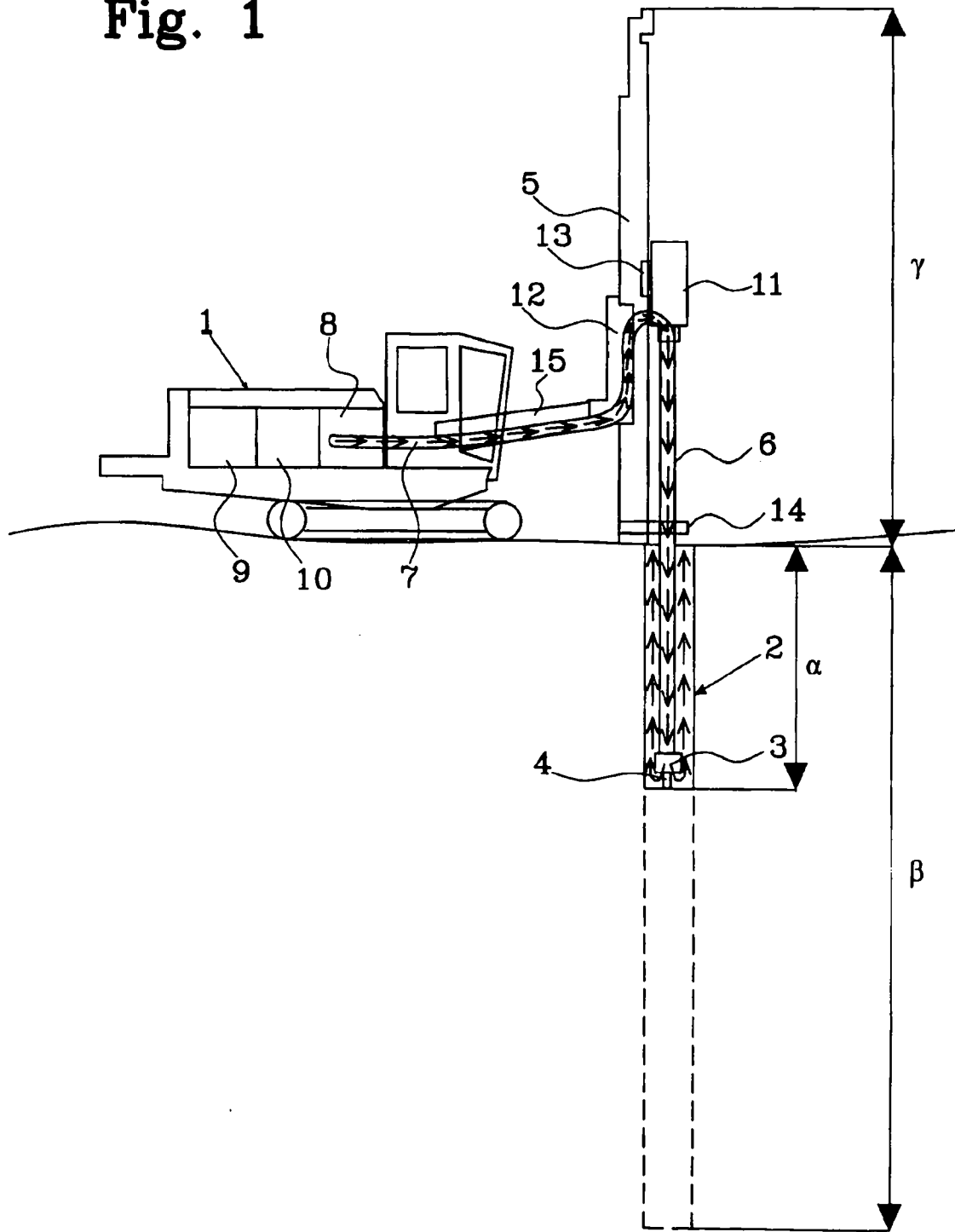

2/2

Fig. 2

