



INTERNATIONAL APPLICATION PUBLISHED UNDER THE PATENT COOPERATION TREATY (PCT)

(51) International Patent Classification³ : B01D 13/04, 13/00, 31/00 C13J 1/08; C13D 3/16	A1	(11) International Publication Number: WO 83/ 02905 (43) International Publication Date: 1 September 1983 (01.09.83)
(21) International Application Number: PCT/AU83/00023 (22) International Filing Date: 22 February 1983 (22.02.83) (31) Priority Application Numbers: PF 2870 PF 2895 87532/82 (32) Priority Dates: 26 February 1982 (26.02.82) 1 March 1982 (01.03.82) 23 August 1982 (23.08.82) (33) Priority Country: AU (71)(72) Applicant and Inventor: LEFEBVRE, Michel, Serge, Maxime [FR/AU]; 2/6 Buckhurst Avenue, Point Piper, NSW 2027 (AU). (74) Agent: F.B. RICE & CO.; 101 Mort Street, Balmain, NSW 2041 (AU).	(81) Designated States: BR, CF (OAPI patent), CG (OAPI patent), CM (OAPI patent), DK, FI, GA (OAPI patent), GB, JP, KP, LK, NO, SN (OAPI patent), TD (OAPI patent), TG (OAPI patent), US. Published <i>With international search report.</i>	

(54) Title: IMMOBILISED INORGANIC DIFFUSION BARRIERS AND THEIR APPLICATION TO THE SEPARATION OF SMALL MOLECULAR SPECIES FROM A SOLUTION

(57) Abstract

The modification of a diffusion barrier by the deposition of one or more inorganic species within the pores and on to the surfaces of said diffusion barrier to form an immobilised crystalline lattice barrier or molecular grid having substantially uniform permeability and to select and separate different ionic species, giving a high efficiency of separation with a low energy input. The diffusion barrier is characterised by one or more units, each incorporating a tubular housing with a bundle of porous hollow fibres therein, arranged in the axial direction of the housing. The inorganic crystalline lattice is exemplified by barium sulphate (BaSO_4) formed by the interdiffusion of barium hydroxide ($\text{Ba}(\text{OH})_2$) and sulphuric acid (H_2SO_4) solutions, or alternatively, co-precipitated aluminium hydroxide ($\text{Al}(\text{OH})_3$) and barium sulphate (BaSO_4) formed by the interdiffusion of barium hydroxide ($\text{Ba}(\text{OH})_2$) and aluminium sulphate ($\text{Al}_2(\text{SO}_4)_3$) solutions. These immobilised inorganic diffusion barriers are used for selective separation of small molecules (e.g. with a molecular weight of less than 1000 daltons) and provide means for the more effective separation of ionic species. A method is also provided for the low cost removal of ions from molasses, to enhance fermentation efficiency and to improve its usefulness as a stock feed supplement, or it may be followed by other treatments to reduce and/or remove high-molecular weight substances, such as proteins and waxes, to produce sugar syrups and caramel substitutes.

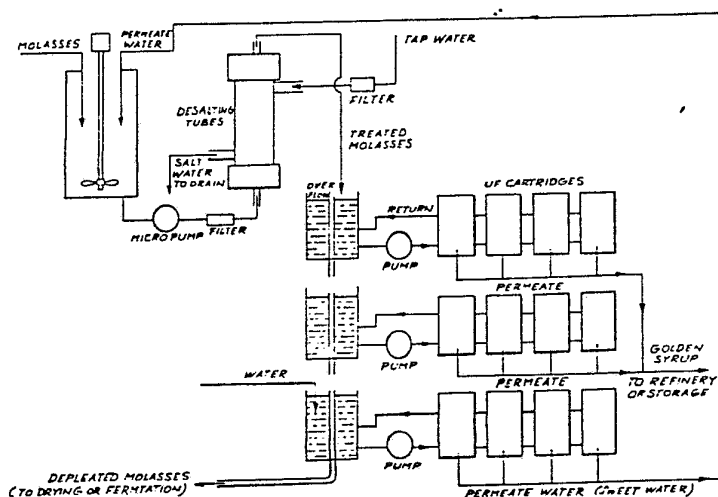

FOR THE PURPOSES OF INFORMATION ONLY

Codes used to identify States party to the PCT on the front pages of pamphlets publishing international applications under the PCT.

AT	Austria	LI	Liechtenstein
AU	Australia	LK	Sri Lanka
BE	Belgium	LU	Luxembourg
BR	Brazil	MC	Monaco
CF	Central African Republic	MG	Madagascar
CG	Congo	MR	Mauritania
CH	Switzerland	MW	Malawi
CM	Cameroon	NL	Netherlands
DE	Germany, Federal Republic of	NO	Norway
DK	Denmark	RO	Romania
FI	Finland	SE	Sweden
FR	France	SN	Senegal
GA	Gabon	SU	Soviet Union
GB	United Kingdom	TD	Chad
HU	Hungary	TG	Togo
JP	Japan	US	United States of America
KP	Democratic People's Republic of Korea		

IMMOBILISED INORGANIC DIFFUSION BARRIERS AND THEIR APPLICATION
TO THE SEPARATION OF SMALL MOLECULAR SPECIES FROM A SOLUTION

Technical Field

5 The present invention relates to the modification of diffusion barriers by the immobilization of inorganic species therein to increase the selectivity of the barrier, and to the use of such barriers in the separation of small molecular species from a solution.

10 Background Art

Various types of membrane diffusion barriers are known according to the published prior art. Molecular and ionic species diffuse through such membranes according to the value of their diffusion coefficient, and for that reason their selectivity is generally poor. Also known according to the prior art are liquid membranes, immobilized liquid membranes or interfacial polymerization membranes which, whilst useful in certain specific applications, suffer the same defects as other previously known membranes.

20 Small molecular weight separations are not easily achieved by economical industrial stage processes. Classical hyperfiltration requires high pressure and high-equipment cost for the low selectivity, low fluxes and the always present risk of membrane fouling. Chromatography, including high pressure liquid chromatography, gives excellent selectivity but is limited to laboratory scale separations, and is a too costly operation for most industrial applications. Ion exchange, ionic exclusion, transport depletion and reverse electrodialysis are processes applicable only when macro-molecules, with isoelectric points different to the overall pH, are not present in large quantities, otherwise poisoning occurs. Furthermore, high investment cost and high operating cost prohibits their use for the treatment of cheap feedstocks for the fermentation industry.

35



Disclosure of the Invention

It is an object of this invention to provide a diffusion barrier for a fluid medium (gas or liquid) with a porosity greater than about 10-20% for channel dimensions of the order
5 of only several Angstrom.

It is also an object of this invention to provide a selective diffusion barrier wherein a predetermined inorganic species is immobilized within the matrix thereof, to produce a diffusion barrier having a substantially uniform molecular
10 grid structure which functions as an effective molecular screen for the selective separation of small molecules (e.g. molecular weight less than about 1,000 daltons) and provides means for the more effective separation of ionic species. The matrix used can be any known diffusion barrier e.g.,
15 sintered glass, dialysis membranes, porous metals, or any other suitable porous structure.

It is another object of the present invention to utilize existing diffusion barriers as a support to undergo chemical reaction to manufacture a substantially uniform grid of
20 precise molecular size, with regard to the molecular size of the species to be separated.

It is an object of the present invention to provide a substitute for ion exchange; to provide a method of separating ionic species and non-charged species from an
25 organic media wherein said method has the same effect as direct ion exchange treatment but which avoids the disadvantage of poisoning of the ion exchange resin.

It is a further object of this invention to provide a method of, and means for, the separation of small ionic or
30 molecular species from a liquid and for fractionation of said liquid by the use of a diffusion barrier having a uniform pore or molecular grid structure or uniform permeability, wherein the diffusion of small ionic or molecular species is obtained against the osmotic current through said molecular
35 grid structure to achieve a selectivity greater than the



ratio of the relative diffusion coefficient of the separated species.

It is another object of this invention to provide a method of using unitary separative units to increase the
5 original separation factor of such units by use of a cascade system; to provide a method of increasing the separation factor between two components in a liquid phase which are required to be separated, without using the multi-stage recycling of classical cascade systems.

10 It is yet a further object of this invention to provide a method for the desalting of molasses to upgrade the value thereof and to provide the basis for improved sugar recovery therefrom or for the production of a liquid sugar product or a product equivalent to high test molasses. It is also an
15 object to provide an improved feedstock for fermentation which increases the rate of fermentation, the yield of alcohol or other products and the solids concentration of the effluent.

These and other objects of the invention will be further
20 discussed in the following description of the invention.

According to one aspect of the present invention there is provided a method of immobilization of an inorganic material inside a diffusion barrier in the form of a
25 colloidal-, crystalline-, semicrystalline- species, or a mixture thereof, with control of the physical structure of the immobilized species, and without plugging of the outside surfaces of the diffusion barrier. A diffusion barrier so treated, in most cases would not normally lose any more than about 10% of its original permeability.

30 According to another aspect of the invention there is provided a process for the separation of small molecular species from a primary liquid (e.g. molasses or molasses fermentation dunder) containing one or a plurality of dissolved molecular species of different molecular weight,
35 comprising subjecting said primary liquid to treatment with a



diffusion barrier having substantially uniform matrix permeability which separates the primary liquid from a solvent (e.g. water), wherein an osmotic gradient exists between the primary liquid and the solvent, and whereby small
5 molecular species, especially salts, are selectively transferred from the primary liquid to the solvent against the osmotic current.

The diffusion of the small molecular species against the osmotic current provides a selectivity greater than the ratio
10 of the relative diffusion coefficient of the separated species.

Although the diffusion barrier to be used may be any suitable porous diffusion medium having uniform permeability to enhance the selectivity of the separative process, the
15 preferred diffusion barrier comprises hollow fibres contained in a hollow fibre tube unit having substantially uniform permeability, wherein the primary liquid is circulated through the inner channels or lumens of a bundle of hollow fibres and wherein the solvent is circulated in the space
20 surrounding the bundle of hollow fibres, whereby the small molecular species can diffuse through the molecular screen provided by the uniform grid structure in the walls of the hollow fibres against the osmotic current and into the solvent.

25 In another aspect of the present invention the solvent circulating in the space surrounding the bundle of fibres is further treated in a cascade system to separate the molecular species contained therein. Preferably the solvent circulating in the space surrounding the bundle of hollow
30 fibres is circulated to the space surrounding the bundle of hollow fibres of a second hollow fibre tube unit wherein an osmotic gradient exists between the solvent in said space and a further solvent circulating through the interior channels or lumens of the hollow fibres of the second hollow fibre
35 tube unit, whereby small molecular species are selectively



- 5 -

transferred from the solvent in said space to the further solvent circulating through the interior channels or lumens of the hollow fibres of the second hollow fibre tube unit. The treated solvent from the space surrounding the bundle of hollow fibres of the second hollow fibre tube unit is normally circulated back to the space surrounding the bundle of hollow fibres of the first hollow fibre tube unit. In order to regulate or to control the concentration of dissolved material being recirculated with the solvent in the coupled hollow fibre tube units, a part of the treated solvent from the space surrounding the bundle of hollow fibres of the second hollow fibre tube unit is circulated back to the stream of primary liquid to be treated by the first hollow fibre tube unit. Pure solvent (e.g. water) can be added to the circulating solvent stream to replace the volume of solvent which has been circulated back to the stream of primary liquid (e.g. molasses) to be treated.

It is also within the scope of the invention for the solvent to be further treated by ion exchange or other treatment capable of fixing by adsorption the species to be removed from the solvent.

According to a further aspect of the present invention there is provided a process for the fractionation of a primary liquid (e.g. a sugar-containing solution such as molasses, or dunder from the fermentation of molasses) containing a plurality of dissolved molecular species of different molecular weight, comprising:

- (i) subjecting the primary liquid to treatment with a diffusion barrier which separates the primary liquid from a second liquid (e.g. water), wherein an osmotic gradient exists between said primary and second liquids and whereby small molecular species (e.g. salts) are selectively transferred from the primary liquid to the second liquid against the osmotic current; and

- (ii) subsequently subjecting said primary liquid to ultrafiltration with a semipermeable membrane,
- permitting the passage therethrough of water or other solvent component of said primary liquid together with molecules below a predetermined size contained therein (e.g. sugar molecules), to form a permeate of treated product containing said molecules, and
 - preventing the passage of molecules above said predetermined size (i.e. macromolecular species, such as proteins) to form a concentrate or retentate of the remaining components of the primary liquid.

The invention also relates to products - such as molasses or dunder from the fermentation of molasses - which have been treated by the above-described processes and to the fractionated products - such as sugars (in liquid or crystalline form) and protein - obtained as a result of such processes.

In yet another aspect of the present invention there is provided apparatus for the fractionation of a primary liquid containing a plurality, of dissolved molecular species of different molecular weight, comprising:

- (i) porous diffusion barrier means with a molecular grid matrix and having substantially uniform grid permeability to enhance selectivity and being adapted to separate said primary liquid from a second liquid whereby small molecular species may diffuse from said primary liquid to said second liquid under the influence of an osmotic gradient between the primary and second liquids; and
- (ii) ultrafiltration means whereby said primary liquid may subsequently be selectively split into a permeate of a product containing solvent and molecules below a predetermined size, and a concentrate or retentate

- 7 -

comprising molecules above said predetermined size.

Ideally, the uniform grid permeability of the diffusion barrier is such that the diffusion of the small molecular species against the osmotic current results in a selectivity
5 greater than the ratio of the relative diffusion coefficient of the separated species.

Preferably, the diffusion barrier means comprises one or more hollow fibre tube units, each comprising a tubular housing; a bundle of porous hollow fibres arranged within the
10 housing in the axial direction thereof; a countercurrent liquid chamber formed between the outer surfaces of the hollow fibre bundle and the inner surface of the housing; first inlet and outlet ports for passing the second liquid into and out of the liquid chamber; partition walls
15 supporting the hollow fibre bundle, separating the open ends of the hollow fibres from the liquid chamber and defining the length of the liquid chamber; and second inlet and outlet ports for the primary liquid phase, the second inlet and outlet ports communicating with the interior space or lumen
20 of each of the hollow fibres, and wherein a plurality of channels of predetermined molecular dimensions and permeability communicate between the interior space or lumen of each hollow fibre and the liquid chamber.

Preferably, in order to provide a system whereby the
25 second liquid circulating in the countercurrent liquid chamber may be treated to remove dissolved ionic or molecular species therefrom, for example as may be required for environmental considerations, a cascade system may be provided wherein the first inlet and outlet ports of each
30 hollow fibre tube unit are connected in series to the first inlet and outlet ports of a second hollow fibre tube unit for circulation of the second liquid therebetween.

In a further modification thereof, an open cascade system is provided wherein means are provided for directing
35 at least part of the treated second liquid back to the stream



of primary liquid to be treated by said apparatus, and wherein further means are provided to add pure second liquid (e.g. ultrafiltered water) to replace the treated second liquid which has been removed.

5 The cascade system contains a solvent for the stripped molecule, which can be different to the solvent used for the primary liquid, and for the outside stripping current of the second unit, provided that if this solvent is different, it is not miscible with the other two solvents.

10 As a further modification of the invention, ion exchange means and/or other means capable of fixing the dissolved species by adsorption may be provided to remove compounds from the second liquid which have diffused therein from the primary liquid which have diffused therein from the
15 primary liquid. For example, the apparatus may also comprise one or more of the following features.

- (i) one or more ion exchange resins to selectively remove the ions or charged molecules required to be stripped, and which can be regenerated by
20 classical ion exchange using a strong base or a strong acid.
- (ii) one or more Sirotherm-type units, as developed by the CSIRO, which can strip the current from charged species and which can be regenerated by
25 thermic treatment.
- (iii) one or more adsorption units e.g., activated carbon, which can be regenerated by thermic treatment.
- (iv) one or more metastable ionic systems which can
30 be regenerated by differential pressure.
- (v) a solvent inlet, if the solvent used is the same as the base solvent of the primary liquid being treated, to maintain the volume of the closed circuit system constant, and to equilibrate the
35 transfer of solvent due to the difference in

osmotic pressure between the inner core and the outer core of the first unit, and in this particular case taking into account the lesser transfer of the same nature occurring in the second unit.

5

(vi) a unit for selective separation of a two-phase liquid when the closed circuit uses a two-component fluid of non-miscible solvent - as in solvent extraction where one solvent is the solvent used in the primary liquid being treated, whereas the other solvent is a better solvent for the species to be stripped than is the first mentioned solvent.

10

(vii) a device to make an emulsion of one solvent in another when feature (vi), above, is used.

15

(viii) a pump to ensure recirculation.

(ix) an outlet from the closed circuit to bleed the product in recirculation back to the original product to be treated.

20

Classical dialysis processes use membranes, isotropic or anisotropic, with pore dimensions small enough to limit water convection by a sufficient amount so as to avoid interference between molecules and their first sphere of hydration, and the wall. Under these circumstances,

25

classical diffusion laws apply, and dialysis is performed in direct relationship with the respective values of the molecular species concerned. Pore uniformity, in this case is not critical and the value of measured diffusion coefficients are in essence the same as the ones measured in sintered glass diffusion cells (this being corrected using the relative value of membrane resistance and interface resistance (see Scheitzer, "Handbook of Separation Techniques", McGraw-Hill).

30

However, with a uniform grid of molecular dimensions close to half the mean free path of the respective molecules,

35

- 10 -

selective counter dialysis occurs. This effect is possible only if none of the pores offer free passage to solvent detrimental to the equilibrium water flux/diffusion, or, in other words, if bulk back diffusion is minimal.

5 In this process, a membrane or other diffusion barrier is interfaced with two fluids: one with high osmotic pressure, the other with low osmotic pressure. Fluid 1 contains various low molecular weight species, to be selectively transferred to Fluid 2. If we consider two
10 molecular weight species (a) and (b) with bulk concentration in Fluid 1 being C_{1A} and C_{1B} transferable through the membrane pores, each species transfers according to their relative concentration gradient and their diffusion coefficient with local transport vectors D_A and D_B . A
15 counter current of water inside the pore, corresponds to a local transport vector D_W . D_A and D_B are directly related to the thin wall concentration gradient (i.e. C'_{1A} , C'_{1B} , C'_{2A} , C'_{2B} replaced C_{1A} , C_{1B} , C_{2A} , C_{2B} in respective equations). In the same manner D_W depends on
20 the real osmotic pressure difference between the two membrane walls and not the osmotic pressure difference measured from the bulk concentration of the species (due to concentration polarisation). Variation of C'_{1A} versus C_{1A} , or more generally C' value versus C values, are governed by the Blatt
25 equation which expresses the influence of shear rate on concentration polarisation. For a given value of C_{1A} it is always possible to choose a value of D_W such as

$$|D_B| < |D_W| < |D_A|$$

by adjusting the shear rate values relative to Fluid 1 and
30 Fluid 2 or the pressure gradient across the membrane to selectively modify D_W .

However, in practice, the dimensions of the modified pore structure (i.e. from about 50 Angstrom to about 10 Angstrom) are such that phenomena other than classical
35 diffusion have to be taken into account, and the present



invention utilises the maximum interaction between the immobilized inorganic species, the ionic species in solution and/or the first or second sphere of hydration.

In this regard, at least four separate phenomena have to be considered as complimentary to classical diffusion:-

- (i) Anomalous diffusion phenomena. In the example given above D_A and D_B can be influenced by the relative local concentration gradients of the two species, the less mobile ion being slowed down by the most mobile ion - e.g., K^+ diffuses faster than Na^+ ; if the concentration of Na^+ increases then the rate of diffusion of K^+ will increase whilst that of Na^+ decreases.
- (ii) Donnan equilibrium effect to respective electroneutrality of transfer.
- (iii) Ionic species which are associated with water through strong or tight bonds for their first sphere of hydration, are generally associated with a second sphere of hydration through loose or weak bonds, which can be explained only by the partial orientation of the molecule of water or solvent outside of the first sphere or hydration. In this case the second sphere of hydration is defined by a level of energy being the difference between the energy state of the random molecule concerned, and the partly re-entered state. The channel dimensions at the level of the second sphere of hydration are used to selectively influence the diffusion of the species. In this regard, the minute difference between the energy levels involved in the coordination of the solvent molecules inside the second sphere of solvation allows for discrimination between ionic species which have the same outer shell electron structure (e.g. between hafnium and Zirconium).
- (iii) Close molecular interactions between wall, solute and solvent. The coordination energy between a wall and an

- 12 -

adjacent ionic species can be used to differentiate between ionic species, and this energy is linked to the solubility product of the molecular species obtained by the combination of oppositely charged ions in the wall. For example, if Barium Sulfate is used as the major component of the grid, SO_4^{2-} ions will not diffuse, or will diffuse much slower, because the solubility product $[\text{Ba}^{2+}][\text{SO}_4^{2-}]$ is extremely small, but Cl^- ions will diffuse without measurable difference compared to the normal diffusion coefficient, because the solubility product $[\text{Ba}^{2+}][\text{Cl}^-]^2$ is large.

Best Mode of Carrying Out the Invention

Expressed in another way, a reaction is effected between two reactants, each in the form of a solvent and a solute circulating on opposite sides of a primary matrix. For example, if the matrix is in the form of a hollow fibre the reaction is conducted between two solutions 'A' and 'B', containing solutes 'a' and 'b', respectively, circulating on opposite sides of the hollow fibre matrix, with 'A' on the outside and 'B' on the inside.

The components to be immobilized are insoluble in both solvents 'a' and 'b', or at least totally insoluble in one of them.

For immobilization of a predetermined compound 'c', obtained by the reaction between solutes 'a' and 'b' according to the following reaction scheme:



the active ionic parts of 'a' and 'b' each have their stoichiometric proportions determined by the reaction, but corrected by their diffusion coefficient or their ionic mobility.

For example, the immobilization of Barium Sulfate (Ba SO_4) inside a hollow fibre-type membrane is effected by the reaction between Barium Hydroxide (Ba (OH)_2) solution



- 13 -

outside the hollow-fibre and Sulfuric Acid solution (H_2SO_4) inside the fibre. The rate of reaction is controlled so as to have stoichiometric proportions of Ba^{2+} and SO_4^{2-} inside the membrane at the start of the
5 reaction.

In other words the value of the diffusion coefficient for SO_4^{2-} is used to correct the concentration of H_2SO_4 used to have the same ionic concentration as Ba^{2+} at the interface. Expressed in another way, it is not
10 sufficient to simply determine the stoichiometric proportions of the two solutions which are used, as it is also necessary to take into account the different speeds of diffusion. Diffusion coefficients of various ionic species can be found
15 by reference to standard texts. Multiplication of the appropriate diffusion coefficient by the concentration of the ionic species gives the quantity of ions which will be present at a certain time at the interface. With this figure determined it is then necessary to check the quantity of ions of the other species which will be present and to adjust the
20 concentration if necessary such that exactly the same concentration or stoichiometric proportion will be present at the interface, concurrently. In respect of the formation of crystals of inorganic species in the membrane, allowance can be made as far as the diffusion coefficients are concerned by
25 the variation of such diffusion coefficients versus temperature if the temperature of the two streams are not the same.

A slight disequilibrium, with a higher concentration of component 'a', will create immobilization on the side in
30 contact with component 'b'. In other words, in the example given above, if the concentration of $\text{Ba}(\text{OH})_2$ which is used is higher than the predetermined concentration, the $\text{Ba}(\text{OH})_2$ outside of the hollow fibre will cause the immobilization of Ba SO_4 on the inner core of the hollow
35 fibre.



In the general reaction sequence given above, any reaction between 'a' and 'b' which produces at least one insoluble product in one of the solvents contained by solutions 'A' and 'B' can be used.

5 The density of the precipitate will be highest in the layer which is formed initially, but will be gradually lower for subsequently formed layers inside the fibre, extending to the outside side of the hollow fibre.

10 It is also within the scope of the present invention to immobilize two different layers of inorganic species in and on the diffusion barrier, one inorganic species giving selectivity for one specific component, the other inorganic species giving selectivity for one or more other components contained in the solution being treated.

15 In practice it is normally possible to take any inorganic compound which is not soluble in one of the solvents which is being used. From the chemical formula of this compound it is possible to determine the reaction scheme or sequence which will lead to that compound. With two
20 components in the reaction, the diffusion coefficients are determined for each component, and based on the teachings of the present invention it is possible to determine the requirements to effect immobilization of the compound.

25 The preferred diffusion barrier is a porous hollow fibre with a wall thickness of about 3 to about 15 microns and an internal channel height or diameter of about 200 microns.

30 In an embodiment of the invention relating to the desalting of molasses, the diffusion barrier used was a 1.8 square metre hollow fibre unit, treated such that $\text{Al}(\text{OH})_3$ and BaSO_4 were immobilized therein as a co-precipitate, obtained by the reaction between $\text{Al}_2(\text{SO}_4)_3$ and $\text{Ba}(\text{OH})_2$. To work out the precise concentrations required the above described technique (determining diffusion
35 coefficients, etc) is followed, with the regeneration of a



- 15 -

solution of saturated $\text{Ba}(\text{OH})_2$ outside the hollow fibre and $0.158 \text{ N H}_2\text{SO}_4$ inside. With this system, typically 500 gm of molasses is diluted with 500 ml of H_2O , giving a total volume of 830 ml, and this solution is circulated inside the hollow fibre with a flow rate of 400 ml/minute. Outside the hollow fibre H_2O is circulated at a flow rate of 2 litres/minute.

With such diffusion barriers of the type referred to above, the mechanism for selectivity is of five types:-

- 10 (1) Selectivity by ionic interaction. When you have an inorganic precipitate as a barrier, the remaining charge influences the flow of molecules by proximity influence, e.g., BaSO_4 is selective against SO_4^- but allows Cl^- to pass.
- 15 (2) Differential site-to-site transport, e.g., an hydrophobic barrier will selectively transport any agent which can be solvated, especially any plasticizer of such a barrier against water. Site-to-site transport is a step-by-step operation, which includes:-
 - 20 (i) adsorption of molecules;
 - (ii) diffusion through the barrier, and
 - (iii) desorption from the barrier to the second layer.
- (3) Selectivity by virtue of the osmotic gradient between two liquid phases separated by the barrier. In this case, solvent counter-current opposes the transport of the diffusing species. If the maximum grid dimension is less than the free path of the diffusing molecule, the counter-current effect of solvent makes a selective separation against the apparent surface of resistance offered by the molecule to the flow of solvent transported back.
- 25 (4) Anomalous diffusion, as described above.
- (5) Selective counter dialysis, as described above.

Unfortunately, these selective modes - and especially those outlined in (2) and (3), above - are not 100%

effective. In the case where it is required to make a separation between small ionic species and small non-charged species, it is difficult to obtain a complete separation - and especially to completely block the transport of
5 non-charged species e.g., in the case of the desalting of, or the selective removal of ionic species from, a complex organic media, where it is required to avoid the transport of small organic molecules, such as in the desalting of any sugar syrup (e.g. molasses).

10 One classical prior art method to achieve such a separation is to use ion exchange resins, which give in two steps the deionization of the complex mixture.

Unfortunately, ion exchange sites prepared in a microporous matrix are very sensitive to poisoning by large
15 organic molecules which are, in most cases, present in the original media. For this reason it is important to avoid any contact between molecules bigger than the inner pore structure of the ion exchange resin, and the resin itself.

The invention will be further described with reference
20 to an embodiment thereof relating to the desalting of cane sugar molasses.

In general terms, molasses contains about 55% sugars by weight (80% by volume), 25% water and approximately equal amounts of salts and large organic molecules. The large
25 molecules (molecular weight above 20,000) are mainly proteins and waxes and the salts primarily comprise K, Mg, Na and Ca ions associated with chlorides and sulphates as counter ions.

The sucrose content in molasses varies between 25 to 40%, and the reducing sugars range from 12 to 35%, but the
30 sum of the two generally constitutes at least 50 to 55% of the final molasses.

However, the accumulation of salts and higher organic molecules in molasses constrains economic sugar recovery therefrom, and reduces its value in fermentation and in the
35 stock food industries.



The high salt content of molasses, especially potassium salts in molasses from sugarcane, has limited its final utilization. The combination of high ash and non-sugars content in molasses limit the recovery of residual sucrose due to complex solubility reactions. In addition the high potash levels in molasses have a laxative effect which limits molasses utilization in animal feeds.

Currently available techniques for salt removal from molasses are based on ion exchange and electrolysis. However, because the high molecular weight components in molasses cause resin and membrane fouling no commercially viable process has been developed for the cane sugar industry.

By means of the use of the present invention it is possible to remove the bulk of the salts (potassium, calcium and magnesium salts in particular) and other small molecules from the molasses to provide treated molasses which is a more useful product for use in more efficient fermentation and for stock food applications.

By subjecting the treated molasses to specific ultrafiltration treatment, it is possible to effectively remove the macromolecular organic compounds (wax, proteins, polycellulosic material) thus creating the conditions for the complete recovery of the sugar content of the molasses, e.g. in the form of a sugar syrup, from which the sucrose can be crystallised, if required. By a combination of hollow-fibre separation and ultrafiltration technology it is possible to deplete the input molasses of a major portion of its salt and large MW species. This yields a sugar syrup or a product equivalent to treacle or "golden syrup".

According to this embodiment of the invention, the molasses is subjected to an osmotic desalting treatment in a series of hollow-fibre separation units. Preferably, each separation unit comprises a highly selective and highly porous diffusion barrier, with the hollow fibres consisting of regenerated cellulose, being of substantially uniform pore

structure and wherein a predetermined inorganic species in the form of a crystalline lattice is immobilized within the hollow-fibre structure, both in the membrane pores and on the surfaces. In this way each hollow-fibre comprises a
5 substantially uniform grid of precise molecular size, with regard to the molecular size of the species to be selected or separated. The type of crystalline lattice can be changed to vary the rejection characteristics of the diffusion barrier.

Molasses is passed through the hollow fibres
10 countercurrent to a stream of water (or ultrafiltered water) flowing around the outside of the hollow fibres. Each hollow-fibre unit has an inlet (with pre-filter) and an outlet for the molasses feed and an inlet and an outlet for the counter-current water flow. The pores are such that they
15 will prevent transfer of sugars to the countercurrent water flow, which is further inhibited by the inward flow of water molecules. However, potassium, calcium and magnesium ions are able to move counter to this flow via an ionic diffusion transport mechanism, as described above..

20 Brief Description of the Drawings

The embodiment of the invention relating to the desalting of molasses will be further described with reference to the drawings, in which:-

Fig. 1 illustrates a schematic representation of
25 apparatus embodying principles of the present invention and comprising one or more hollow fibre desalting tube units, possibly in one or several banks of such tubes connected in series or in cascade form, depending upon the level of desalting required, and further comprising one or more banks
30 of ultrafiltration units to separate the sugars from the macromolecular components of the molasses, such as proteins and waxes.

Fig. 2 illustrates an open cascade arrangement for the desalting of molasses designed for the recovery of the bulk
35 of any of the sugar content of the molasses which may have

bled into the countercurrent water and which is required to be treated before drainage thereof.

Each hollow fibre desalting unit according to the preferred embodiment has an active surface area of 1.8m^2 and comprises a plurality (9,000 to 15,000) hollow fibres with a wall thickness of about 3-15 microns, an internal channel or lumen diameter of about 200 microns. The hollow fibres have a porosity ratio of about 20% with pores or molecular screens of about 10 Angstrom.

10 As shown in Fig. 1, molasses - diluted with water if necessary - is pumped through the internal channels of the hollow fibres with filtered or ultrafiltered tap water pumped in countercurrent in the space surrounding the hollow fibres. Under the influence of the osmotic gradient which
15 exists, certain ions - including potassium, calcium and magnesium ions - diffuse through the molecular screen provided by the porous wall structure of the hollow fibres, with some water flowing back through the channels and into the molasses stream. According to the flow rate of the
20 molasses pumped through the hollow fibre tubes, and the level of desalting which is required, the molasses may be passed through one or a plurality of banks of such hollow fibre tubes (with tubes in each bank in parallel) to obtain the required level of desalting. For example, the potassium
25 content may be reduced by up to about 90% of the original potassium content, depending upon the number of hollow fibre tube units used and the particular operating conditions applied. More than half of one of the most prolific salts in molasses, potassium, can be removed in a single pass through
30 a bank of hollow fibre tubes. A 60 tube module can produce 1.8 tonnes per hour of substantially desalted molasses while using less than 4m^3 of water per hour with a power consumption of less than 4KW. Operating pressures are typically less than 50 kpa but depend on the viscosity of the
35 molasses, temperature, flow rate and the desired level of

desalting.

Ion levels in the molasses can be determined by atomic absorption spectroscopy before and after passage through the hollow fibre tubes.

- 5 The following results have been obtained for a 1.2m² membrane using molasses diluted to 520g/l sugar concentration:

No. of Passes	Ion Concentrations (g/l)				
	K ⁺	Na ⁺	Mg ⁺	Ca ⁺⁺	Cl ⁻
10 Control	41.4	1.1	4.6	8.4	21.3
1 Pass	26.0	0.72	3.2	7.0	12.4
2 Pass	20.0	0.60	2.5	5.0	9.5
3 Pass	14.0	0.49	2.0	4.6	6.8

15 At this stage, if required, the treatment of molasses can be terminated and the desalted molasses returned to the refinery or to the fermentation plant.

- 20 However, the desalted molasses may be further treated, in a second phase, by subjecting the desalted molasses to ultrafiltration, to eliminate macro-molecules which have a molecular weight higher than the sugar, i.e. to remove the protein and the wax.

- 25 By a combination of hollow-fibre separation and ultrafiltration technology, as shown in Fig. 1, it is possible to deplete the input molasses of a major portion of its salt and large MW species. This yields a sugar syrup or a product equivalent to "Golden Syrup".

- 30 The desalted molasses is circulated through a three-stage ultrafiltration system of capillary modules, as shown in Fig. 1. Ultrafiltration effects the separation of different molecular sizes through porous membranes in thin channels at high velocity. Various molecular weight cut-offs
35 are available to adjust the wax and macromolecular content of



the molasses to meet market needs and requirements.

The combined effect of the hollow fibre desalting tube and the ultrafiltration equipment permits the removal of the small molecular fraction and the high molecular fraction thus leaving a syrup which contains the sugars (sucrose and invert

5 sugars) and some colouring agents of intermediate molecular weight. This product (treacle or golden syrup) can be either:
- Directly used as a liquid sugar substitute and eventually a natural colouring agent (the colour can be
10 adjusted by modification of the molecular weight cut-off of the UF membrane).

- Concentrated by multiple effect evaporation to be shipped and used in sensitive fermentation areas (baker's yeast, citric acid, mono sodium glutamate, pharmaceuticals).

15 - Returned to the refinery for sucrose extraction; the low potassium content and the absence of high molecular compounds permits two thirds sucrose recovery per strike.

The equipment is readily tuneable or adaptable to the user's requirements; it is a simple matter to adjust the
20 apparatus to modify the salt content of the product.

Furthermore, the use of different ultrafiltration membranes allows the manufacturer to selectively control the amount of small molecules related to color, taste and surfactant properties for enhancement of colour, taste and
25 eventually mechanical properties of the end product.

The first two stages of the ultrafiltration unit produce the sugar syrup. In the third stage water is added to rinse the molasses. The permeate from Stage III (very dilute syrup "sweet water") is recycled back to the
30 counter-current mixer where it is used to dilute the incoming molasses prior to the desalting stage. Because it is a closed loop system, there is no loss of sugar.

The depleted molasses flow from Stage III is primarily a protein concentrate, containing about 25% protein and wax
35 W/W. For small installations the protein concentrate will

- 22 -

simply be discharged to an anaerobic septic tank. For larger installations (e.g. treating in excess of 10,000 tonnes molasses/year) it may be feasible to install a dryer to recover the protein concentrate in powder form. The protein concentrate solution is stable only for about 3 days but when dried it has a stable shelf life of about 12 months.

Fig. 2 of the drawings illustrates an open cascade modification for the hollow fibre tube desalting unit, whether for use as part of the system illustrated in Fig. 1, or for a straight molasses desalting application without the subsequent ultrafiltration treatment.

As shown in Fig. 2, molasses is pumped through the central channels of the hollow fibres of Tube 1 with water pumped at countercurrent in the space surrounding the hollow fibre bundle. To reduce the effect of any sugar bleeding from the molasses into the countercurrent water, said countercurrent water is pumped into the space surrounding the hollow fibre bundle of a second tube (Tube 2) which has been connected to Tube 1. In Tube 2, filtered water is pumped through the central channels of the hollow fibres wherein, under the influence of an osmotic gradient, salts in the water surrounding the hollow fibres diffuse through the porous walls of the hollow fibres and into the water which is circulating through the central channels of the hollow fibres, after which it is passed to the drainage system. The bulk of the sugars which have bled into the water surrounding the hollow fibre bundle of Tube 1 are normally retained in the water circuit between Tubes 1 and 2.

In order to control the level of sugars circulating in the water between Tubes 1 and 2, part of this water is bled off (as shown in Fig. 2) and is recirculated back to the incoming molasses stream where it serves a useful purpose of diluting the feed molasses to an acceptable level of dilution for pumping through the thin channels of the hollow fibres. The sugar-containing water which is bled off is replaced by

ultrafiltered water which is feed into the looped circuit between Tubes 1 and 2, as shown in Fig. 2.

In one experimental application molasses containing 50% by weight of sugars and 5% salts was passed through Tube 1. The resulting desalted molasses from Tube 1 contained 49% sugars and 2% salts (i.e. 60% desalting). Consequently, the countercurrent water in Tube 1 contained 3% salts which had diffused through the walls of the hollow fibres from the molasses into the countercurrent water, as well as the 1% of sugars which had bled into the water.

When the countercurrent water was passed into the space surrounding the hollow fibres of Tube 2, and was treated against pure water circulating through the central channels of the hollow fibres of Tube 2, tests indicated that whereas 1.8% of the salts passed into the central channel water, only 0.02% of the sugars bled into this water which was to be directed to drainage.

Thus the water to be recirculated back to Tube 1, or which was to be recirculated back to the incoming stream of molasses, contained the balance of 0.98% of the sugars and 1.2% of the salts. Thus by the open cascade system illustrated in Fig. 2, any loss of sugars by bleeding can be reduced to a minimum, and to an environmentally acceptable level.

The form of the apparatus to be used for the treatment of molasses depends upon the intended end use(s) of the treated molasses and the environmental considerations which must be taken into account at the intended site of operation. Generally, three basic modes of operation are provided.

TYPE 1: Where pollution control is not of primary importance and when the investment has to be minimised, water (preferably ultrafiltered) is fed directly to the outskirt of the tube and molasses to the inner channel (1kg/mn/tube of molasses for 1.5l/mn per tube of water). One, two or three

passes (one, two or three tubes in series of counter-current) can be used to achieve the necessary level of desalting.

TYPE 2: Where pollution control is important (when the factory is not allowed to reject more than 600 ppm of BOD) a double-tube, open-cascade arrangement, as shown in Fig. 2, is used. This equipment is well adapted to the fermentation industry where a high level of dilution is required.

In this case (Cascade Desalting) the use of UF water is limited to the level of dilution needed for fermentation and the desalting water is simply filtered.

TYPE 3: Where pollution control is paramount (when the factory is not allowed any reject in the form of BOD) water consumption has to be minimal and the dilution of the molasses has to be minimised (for example, for further crystallisation of sugar) an ion exchange resin unit replaces tube number two in the cascade arrangement illustrated in Fig. 2.

For each type the following parameters can be defined:

- Desalting level expressed in potassium reduction in % (K%)
- Sugar Loss expressed in (invert Equivalent) % (S%)
- Separation factor = $K\%/S\%$

	<u>TYPE 1</u>	<u>TYPE 2</u>	<u>TYPE 3</u>
Maximum Desalting	95%	50%	99%
Separation Factor	2 steps (6-10)	(30-80)	1 step (complete separation)
Sugar loss per step (as invert)	3%-5%	0.2%-1%	0
UF water per kg of molasses	1.5	0.3-3 *	0.3 **
Filtered water	-	1.5	

* according to dilution

** volume in litres

Potassium - reduced 2-3 fold

- Sodium - reduced 2-3 fold
Calcium - reduced 4 fold
Magnesium - reduced 2-3 fold
Iron - not affected
5 Copper - not affected
Molybdenum - not affected

In the case of a manufacturer fermenting molasses to produce alcohol, the step of desalting molasses makes his fermentation more efficient in the following ways:

10 (i) Increased reactivity:

Lower potassium and chlorine levels, results in shorter fermentation times. As this is the most time-consuming operation, and the step requiring the largest capital invention, the manufacturer now has the capability to
15 treat more molasses in any given period. For example, using Zymomonas mobilis as the micro-organism for fermentation of a 9% sugar concentration, the following fermentation times were obtained for the same level of sugar transformation:

- 20 (a) untreated - 34 hours
(b) 1 pass desalting - 9.5 hours

Similarly, using the yeast Saccharomyces uvarum as the micro-organism, fermentation time was reduced from 32 hours (for untreated molasses) to about 16 hours (using
25 desalted molasses).

The actual increase in fermentation capacity a fermenter can obtain by using the desalting process will depend on such factors as the type of molasses used, the sugar concentration and the type of fermentation
30 micro-organism used.

(ii) Increased Yield:

It is possible to transform more sugar to alcohol from each batch of molasses. This means that a manufacturer can produce more alcohol from a given quantity of molasses.

35 Increased Alcohol Level in the 'Beer':



A most important advantage is that at equilibrium (or even before) the level of alcohol that can be produced in the substrate is higher than the amount of alcohol that can be produced in non-treated molasses. This given three

5 advantages:

- (a) Increased Productivity - more alcohol produced per batch
 (b) Reduced Energy Requirement - distillation of the alcohol requires less energy because there is more alcohol and less water in the beer.
 10 (c) Increased capacity - the reflux of the column can be increased.

The increased efficiency of fermentation, using B.D.C. yeast, significant reduction in the time to reach equilibrium following molasses desalting is shown in the table below:-

15

	Rate of Alcohol Production	Fermentation Efficiency (hm EtOh/L/Hr) %	Max. EtOh Concentration After 16h (% V/V)
Non-clarified molasses	2.0	78	4.5
25 Clarified molasses (same installation)	2.4	80	5
Clarified mollasses	2.4	80	-
30 Clarified and desalted molasses	4.1	88	8.2

Another application of the present invention is the
 35 immobilization of mineral crystals with total selectivity



against NaCl. In other words to have a membrane which is impermeable to NaCl, but which substantially maintains its water permeability; as indicated above, it is a feature of barriers created by the process of the present invention that
5 they do not lose more than about 10% of their original permeability.

Such membranes could find potential use in, for example, concentration of fruit juices (e.g. osmotic pressure about 5 atmospheres) in a run against sea water (osmotic pressure
10 about 35 atmospheres), at absolute minimal energy cost.

The invention further envisages the immobilization of crystals in diffusion barriers in dry form for use as gas permeation barriers. The inventive process of the present invention enables the formation of diffusion barriers with a
15 sufficiently well distributed lattice structure to provide selectivity between gases. Possible applications for such barriers could be the separation of oxygen from the air, the extraction of helium, the purification of gases such as carbonic gas, etc.

20 Although the invention has been described above with reference to specific examples and preferred embodiments, it will be appreciated that the invention is not limited thereby, and that variations are possible without departing from the spirit or scope of the invention as broadly
25 described.



CLAIMS

1. A diffusion barrier having substantially uniform permeability, comprising a permeable matrix having one or more inorganic species deposited within the matrix and onto
5 the surfaces thereof to form an immobilized inorganic molecular grid or screen having a substantially uniform lattice structure.
2. A diffusion barrier as in claim 1, wherein the immobilized inorganic molecular grid comprises a
10 co-precipitate of two separate inorganic materials.
3. A diffusion barrier as in claim 1, wherein the immobilized inorganic molecular grid comprises a composite layer of different organic materials deposited sequentially onto and within said permeable matrix.
- 15 4. A diffusion barrier as in any one of claims 1-3, wherein the immobilized inorganic molecular grid comprises barium sulphate.
5. A diffusion barrier as in claim 2, wherein the immobilized inorganic molecular grid comprises co-crystals of
20 barium sulphate and an aluminium compound.
6. A diffusion barrier as in any one of claims 1-5, wherein a protective coating is deposited onto the immobilized inorganic molecular grid.
7. A diffusion barrier as in any one of claims 1-6, wherein
25 the permeable matrix comprises one or more porous hollow fibre membranes.
8. A method for forming an immobilized inorganic molecular grid or screen on and within the pores or voids of a permeable matrix to provide a diffusion barrier having
30 substantially uniform permeability through its molecular grid structure, comprising interfacing said permeable matrix with separate reactants on either side thereof, each reactant comprising a solvent and a solute, said solutes being capable of diffusion through or into said matrix to react with one
35 another to form a precipitate of the reaction product within



the pores and on the surfaces of said matrix.

9. A method as in claim 8, wherein the stoichiometric proportions of each solute are determined having regard to the relevant diffusion coefficients or ionic mobilities, and to the temperature of each reactant.

10. A process for the separation of small molecular species from a primary liquid containing one or a plurality of dissolved molecular species of different molecular weight, comprising subjecting said primary liquid to treatment with a diffusion barrier having substantially uniform matrix permeability which separates the primary liquid from a solvent, wherein an osmotic gradient exists between the primary liquid and the solvent, and whereby small molecular species, especially salts, are selectively transferred from the primary liquid to the solvent against the osmotic current, and wherein the diffusion of the small molecular species against the osmotic current provides a selectivity greater than the ratio of the relative diffusion coefficient of the separated species.

11. A process according to claim 10, wherein the diffusion barrier comprises a hollow fibre tube unit, wherein the primary liquid is circulated through the inner channels or lumens of a bundle of hollow fibres and wherein the solvent is circulated in the space surrounding the bundle of hollow fibres, whereby the small molecular species can diffuse through the uniform molecular grid matrix structure in the walls of the hollow fibres against the osmotic current and into the solvent.

12. A process according to claim 11, wherein the solvent circulating in the space surrounding the bundle of fibres is further treated in a cascade system to separate the molecular species contained therein.

13. A process according to claim 12, wherein the solvent circulating in the space surrounding the bundle of hollow fibres is circulated to the space surrounding the bundle of



hollow fibres of a second hollow fibre tube unit wherein an osmotic gradient exists between the solvent in said space and a further solvent circulating through the interior channels or lumens of the hollow fibres of said second hollow fibre tube unit whereby small molecular species are selectively transferred from the solvent in said space to the further solvent circulating through the interior channels or lumens of the hollow fibres of said second hollow fibre tube unit.

14. A process according to claim 13, wherein the treated solvent from the space surrounding the bundle of hollow fibres of said second hollow fibre tube unit is circulated back to the space surrounding the bundle of hollow fibres of the first hollow fibre tube unit.

15. A process according to claim 14, wherein a part of the treated solvent from the space surrounding the bundle of hollow fibres of said second hollow fibre tube unit is circulated back to the stream of primary liquid to be treated by the first hollow fibre tube unit.

16. A process according to claim 15, wherein pure solvent is added to the circulating solvent stream to replace the volume of solvent which has been circulated back to the stream of primary liquid to be treated.

17. A process for the fractionation of a primary liquid containing a plurality of dissolved molecular species of different molecular weight, comprising:

(i) subjecting the primary liquid to treatment with a diffusion barrier which separates the primary liquid from a second liquid, wherein an osmotic gradient exists between said primary and second liquids and whereby small molecular species are selectively transferred from the primary liquid to the second liquid against the osmotic current; and

(ii) subsequently subjecting said primary liquid to ultrafiltration with a semipermeable membrane, permitting the passage therethrough of the solvent



component of said primary liquid together with molecules below a predetermined size contained therein, to form a permeate of treated product, and preventing the passage of molecules above said predetermined size to form a concentrate or retentate of the remaining components of the primary liquid.

- 5
18. A process for the separation of small molecular species from a sugar-containing solution, such as molasses, which
- 10 comprises subjecting said solution to treatment with a diffusion barrier having substantially uniform matrix permeability which separates the solution from a solvent, wherein an osmotic gradient exists between the solution and the solvent, and whereby small molecular species, especially
- 15 salts, are selectively transferred from the solution to the solvent against the osmotic current, and wherein the diffusion of the small molecular species against the osmotic current provides a selectivity greater than the ratio of the relative diffusion coefficient of the separated species.
- 20 19. A process according to claim 18, wherein the diffusion barrier comprises a hollow fibre tube unit, wherein the solution is circulated through the inner channels or lumens of a bundle of hollow fibres and wherein the solvent is circulated in the space surrounding the bundle of hollow
- 25 fibres, whereby the small molecular species can diffuse through the uniform molecular grid matrix structure in the walls of the hollow fibres against the osmotic current and into the solvent.
20. A process according to claim 19, wherein the solvent circulating in the space surrounding the bundle of hollow
- 30 fibres is further treated in a cascade system to separate the molecular species contained therein.
21. A process according to claim 20, wherein the solvent circulating in the space surrounding the bundle of hollow
- 35 fibres is circulated to the space surrounding the bundle of



hollow fibres of a second hollow fibre tube unit wherein an osmotic gradient exists between the solvent in said space and a further solvent circulating through the interior channels or lumens of the hollow fibres of said second hollow tube
5 unit whereby small molecular species are selectively transferred from the solvent in said space to the further solvent circulating through the interior channels or lumens of the hollow fibres of said second hollow fibre tube unit.

22. A process according to claim 21, wherein the treated
10 solvent from the space surrounding the bundle of hollow fibres of said second hollow fibre tube unit is circulated back to the space surrounding the bundle of hollow fibres of the first hollow fibre tube unit.

23. A process according to claim 22, wherein a part of the
15 treated solvent from the space surrounding the bundle of hollow fibres of said second hollow fibre tube unit is circulated back to the stream of sugar-containing solution to be treated by the first hollow fibre tube unit.

24. A process according to claim 23, wherein pure solvent is
20 added to the circulating solvent stream to replace the volume of solvent which has been circulated back to the stream of sugar-containing solution to be treated.

25. A process according to claim 19 or 20, wherein the
25 solvent circulating in the space surrounding the bundle of hollow fibres is subjected to ion exchange or other treatment capable of fixing by adsorption the species to be removed from the solvent.

26. A sugar-containing solution, such as molasses or dunder from the fermentation of molasses, when treated by a process
30 according to any one of claims 18 to 25.

27. A process for the fractionation of a sugar-containing solution, such as molasses, which comprises:-

(i) subjecting said solution to treatment with a diffusion
35 barrier which separates the solution from a solvent, wherein an osmotic gradient exists between the solution

- and the solvent, and whereby small molecular species, especially salts, are selectively transferred from the solution to the solvent against the osmotic current; and
- (ii) subsequently subjecting said solution to ultrafiltration
- 5 with a semipermeable membrane,
- permitting the passage therethrough of water or other solvent component of said solution, together with sugar molecules contained therein, to form a permeate of treated product containing said sugar

10 molecules, and

 - preventing the passage of macro-molecular species, such as protein, contained in said solution to form a concentrate or retentate thereof.
28. A process according to claim 27, wherein said
- 15 sugar-containing solution is molasses.
29. A process according to claim 27, wherein said sugar-containing solution is molasses distillation residues or dunder.
30. A product when obtained by a process as claimed in any
- 20 one of claims 27 to 29.
31. Apparatus for the fractionation of a primary liquid containing a plurality, of dissolved molecular species of different molecular weight, comprising:
- (i) porous diffusion barrier means having a substantially

25 uniform matrix permeability to enhance selectivity and being adapted to separate said primary liquid from a second liquid whereby small molecular species may diffuse from said primary liquid to said second liquid under the influence of an osmotic gradient between the

30 primary and second liquids; and

 - (ii) ultrafiltration means whereby said primary liquid may subsequently be selectively split into a permeate of a product containing solvent and molecules below a predetermined size, and a concentrate or retentate

35 comprising molecules above said predetermined size.



32. Apparatus according to claim 31, wherein the uniform matrix permeability of the diffusion barrier is such that the diffusion of the small molecular species against the osmotic current results in a selectivity greater than the ratio of
5 the relative diffusion coefficient of the separated species.

33. Apparatus according to claim 31 or claim 32, wherein said diffusion barrier means comprises one or more hollow fibre tube units, each comprising a tubular housing; a bundle of porous hollow fibres arranged within the housing in the
10 axial direction thereof; a countercurrent liquid chamber formed between the outer surfaces of the hollow fibre bundle and the inner surface of the housing; first inlet and outlet ports for passing the second liquid into and out of the said liquid chamber; partition walls supporting the hollow fibre
15 bundle, separating the open ends of the hollow fibres from the liquid chamber and defining the length of the liquid chamber; and second inlet and outlet ports for the primary liquid phase, said second inlet and outlet ports communicating with the interior space or lumen of each of the
20 hollow fibres, and wherein a plurality of pores or channels of predetermined molecular dimensions and permeability communicate between the interior space or lumen of each hollow fibre and the said liquid chamber.

34. Apparatus according to claim 33, wherein the first inlet
25 and outlet ports of each hollow fibre tube unit are connected in series to the first inlet and outlet ports of a second hollow fibre tube unit for circulation of said second liquid therebetween.

35. Apparatus according to claim 34, wherein means are
30 provided for directing at least part of the treated second liquid back to the stream of primary liquid to be treated by said apparatus, and wherein further means are provided to add pure second liquid to replace the treated second liquid which has been removed.

35 36. Apparatus according to any one of claims 31 to 35,



wherein ion exchange means or other means capable of fixing by adsorption is provided to remove compounds from the second liquid which have diffused therein from the primary liquid.



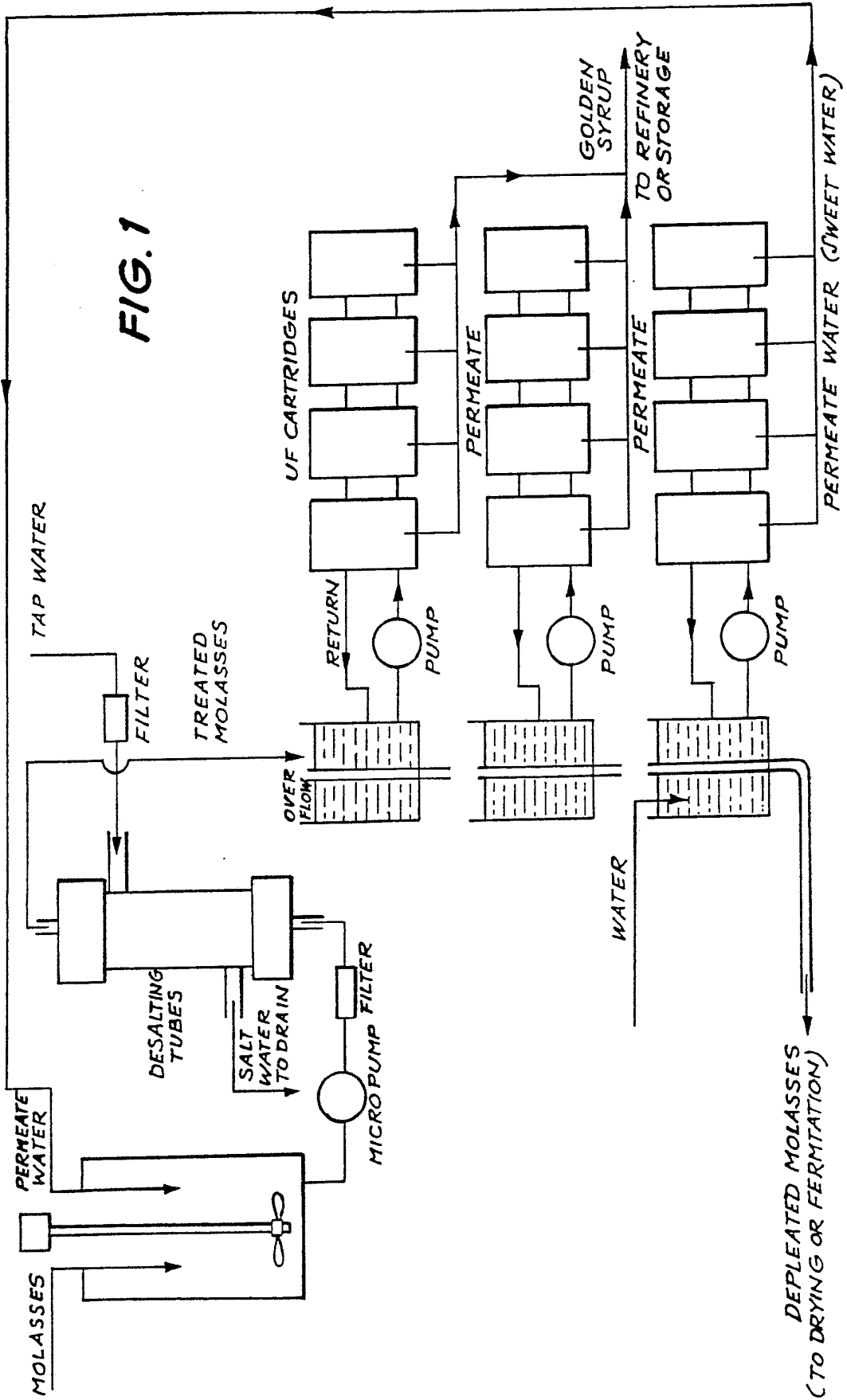

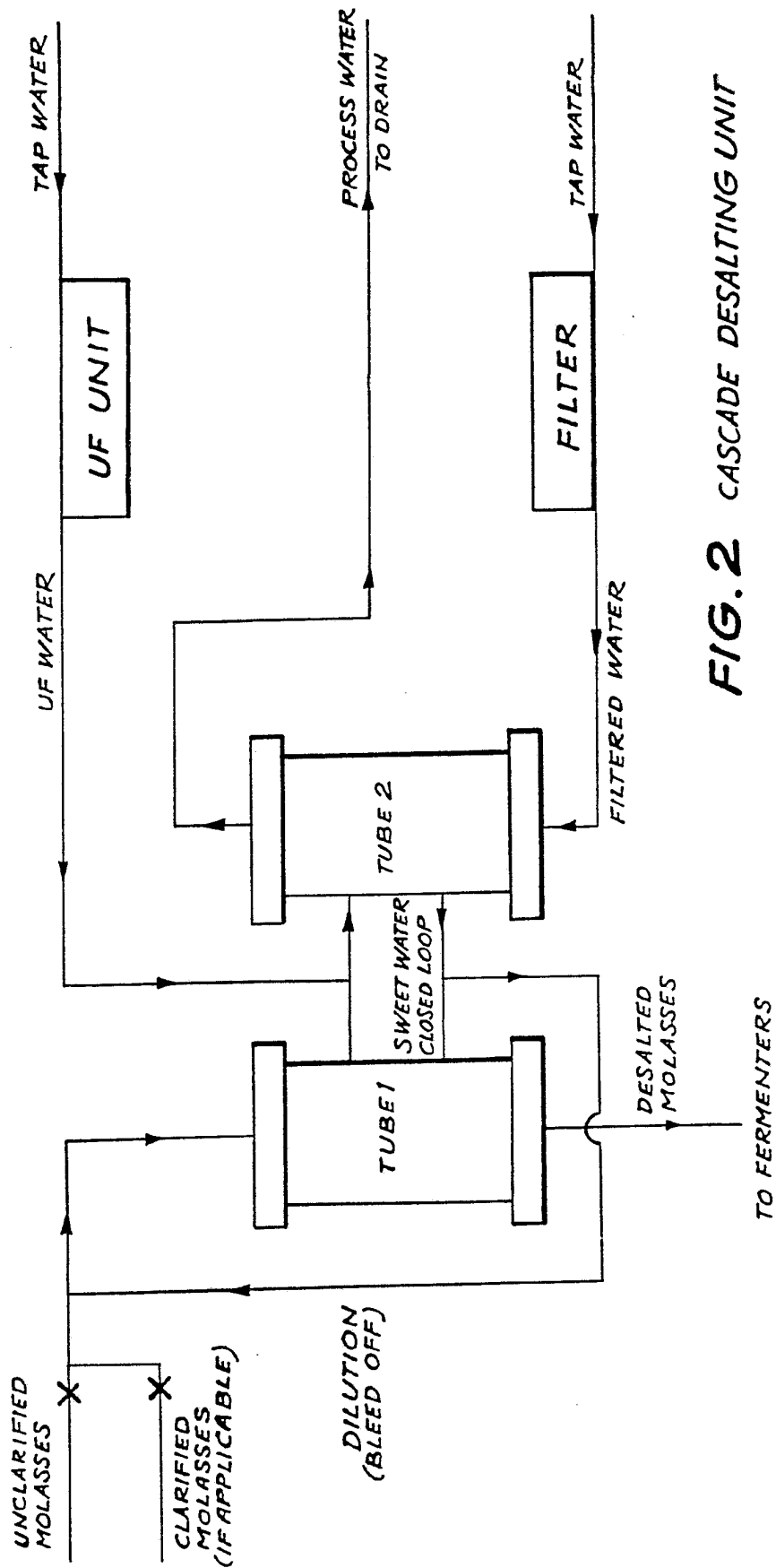

FIG. 2 CASCADE DESALTING UNIT

SUBSTITUTE SHEET



INTERNATIONAL SEARCH REPORT

International Application No **PCT/AU 83/00023**

I. CLASSIFICATION OF SUBJECT MATTER (If several classification symbols apply, indicate all) ³		
According to International Patent Classification (IPC) or to both National Classification and IPC		
Int. Cl ³ : B01D 13/04, 13/00, 31/00, C13J 1/08, C13D 3/16		
II. FIELDS SEARCHED		
Minimum Documentation Searched ⁴		
Classification System	Classification Symbols	
IPC US Cl.	B01D 13/04 210-650; 210-651; 210-652; 210-653	
Documentation Searched other than Minimum Documentation to the Extent that such Documents are Included in the Fields Searched ⁵		
AU: IPC as above		
III. DOCUMENTS CONSIDERED TO BE RELEVANT ¹⁴		
Category ⁶	Citation of Document, ¹⁶ with indication, where appropriate, of the relevant passages ¹⁷	Relevant to Claim No. ¹⁸
X	AU, B, 408042 (12082/66) (UNITED STATES ATOMIC ENERGY COMMISSION) 11 April 1968 (11.04.68) see Claims 1,3, 8,9,10,13,16 & 17 and Examples I to V	(1)
X	AU, B, 414729 (20104/67) (UNITED STATES ATOMIC ENERGY COMMISSION) 17 October 1968 (17.10.68) see Claims 1 to 6 and Examples I to V	(1)
X	AU, B, 512306 (26926/77) (UNION CARBIDE CORPN) 18 January 1979 (18.01.79) see Claims 1 to 5 and Examples (US, A, 4078112, & FR, A, 2358182 & DE, A, 2731260 & JP, A, 53009276)	(1,3,6)
X	AU, A, 69807/81 (NATIONAL RESEARCH DEVELOPMENT CORPORATION) 19 November 1981 (19.11.81) see Claims 1 to 6 and the Examples and page 5 (EP, A, 39179, & GB, A, 2076392, & JP, A, 5616035)	(1,6)
X	EP, A, 0040282 (SOCIETE DE FABRICATION D'ELEMENTS CATALYTIQUES) 25 November 1981 (25.11.81) see Claims and Examples	(1,6)
<p>¹⁵ Special categories of cited documents:</p> <p>"A" document defining the general state of the art which is not considered to be of particular relevance</p> <p>"E" earlier document but published on or after the international filing date</p> <p>"L" document which may throw doubts on priority claim(s) or which is cited to establish the publication date of another citation or other special reason (as specified)</p> <p>"O" document referring to an oral disclosure, use, exhibition or other means</p> <p>"P" document published prior to the international filing date but later than the priority date claimed</p> <p>"T" later document published after the international filing date or priority date and not in conflict with the application but cited to understand the principle or theory underlying the invention</p> <p>"X" document of particular relevance; the claimed invention cannot be considered novel or cannot be considered to involve an inventive step</p> <p>"Y" document of particular relevance; the claimed invention cannot be considered to involve an inventive step when the document is combined with one or more other such documents, such combination being obvious to a person skilled in the art.</p> <p>"&" document member of the same patent family</p>		
IV. CERTIFICATION		
Date of the Actual Completion of the International Search ¹⁹	Date of Mailing of this International Search Report ²⁰	
2 May 1983 (02.05.83)	12 May 1983 (12.05.83)	
International Searching Authority ²¹	Signature of Authorized Officer ²⁰	
AUSTRALIAN PATENT OFFICE	A. A. Moore	

P.T.O.

III. DOCUMENTS CONSIDERED TO BE RELEVANT (CONTINUED FROM THE SECOND SHEET)		
Category *	Citation of Document, ¹⁴ with indication, where appropriate, of the relevant passages ¹⁷	Relevant to Claim No ¹⁸
X	US, A, 3926799 (THOMAS et al.) 16 December 1975 (16.12.75) see Claims 1 to 6 and Example	(1,6)
X	US, A, 3846236 (UPDIKE) 5 November 1974 (05.11.74) see Column 2 lines 47 - 58	(1,8)
X	US, A, 3996141 (UPDIKE) 7 December 1976 (07.12.76) see Claims and Examples	(1,8)
X	US, A, 4069157 (HOOVER et al.) 17 January 1978 (17.01.78) see Claim 1, the Examples 1,4,5,7,8,	(1,3)
X	US, A, 4188418 (LIVINGSTON) 12 February 1980 (12.02.80) see Claim 1, the Examples & column 5 line 13-44	(1,6,7)
X	GB, A, 1228825 (HOPKINS) 21 April 1971 (21.04.71) see page 2 lines 119-123 and page 3 lines 1-33 & Fig.1	(1,6)
X	GB, A, 1534359 (KUREHA, KAGAKU KOGYO K.K) 6 December 1978 (06.12.78) see Claims and Examples (FR, A, 2306010, & DE, A, 2614058, & JP A, 51112783, & SU, D, 730312)	(1,8)
X	GB, A, 1581194 (YEDA RESEARCH & DEVELOPMENT CO.LTD.) 10 December 1980 (10.12.80) see Claims and Examples (FR, A, 2408376 &, DE, A, 2825699 & JP, A, 54014377)	(1,6)
X	S. Glasstone "Textbook of Physical Chemistry" 2nd edition, published 1953 by Macmillan & Co Ltd. (London) see pages 651-655, particularly pages 652-654	(1,8)
X	DE, A, 2537389 (4P VERPACKUNGEN GMBH) 24 February 1977 (24.02.77) see Claims 1,2	(1,8)
X	DE, A, 2750897 (STEMME) 17 May 1979 (17.05.79) see Claim 1	(1)
X	JP, A, 54002276 (MITSUBISHI KASEI K.K) 1 September 1979 (01.09.79) (Japatic English Language Abstract)	(1,6,8)

FURTHER INFORMATION CONTINUED FROM THE SECOND SHEET

V. OBSERVATIONS WHERE CERTAIN CLAIMS WERE FOUND UNSEARCHABLE ¹⁰

This international search report has not been established in respect of certain claims under Article 17(2) (a) for the following reasons:

1. Claim numbers because they relate to subject matter ¹² not required to be searched by this Authority, namely:

2. Claim numbers because they relate to parts of the international application that do not comply with the prescribed requirements to such an extent that no meaningful international search can be carried out ¹², specifically:

VI. OBSERVATIONS WHERE UNITY OF INVENTION IS LACKING ¹¹

This International Searching Authority found multiple inventions in this international application as follows:

Claims 1 to 9: A diffusion barrier and method for its manufacture
 Claims 10 to 30: A method for the separation of different molecular species
 Claims 31 to 36: Apparatus for the separation of different molecular species

1. As all required additional search fees were timely paid by the applicant, this international search report covers all searchable claims of the international application.

2. As only some of the required additional search fees were timely paid by the applicant, this international search report covers only those claims of the international application for which fees were paid, specifically claims:

3. No required additional search fees were timely paid by the applicant. Consequently, this international search report is restricted to the invention first mentioned in the claims; it is covered by claim numbers:

1 to 9

4. As all searchable claims could be searched without effort justifying an additional fee, the International Searching Authority did not invite payment of any additional fee.

Remark on Protest

- The additional search fees were accompanied by applicant's protest.
- No protest accompanied the payment of additional search fees.