



(11) **EP 1 561 882 B1**

(12) **EUROPEAN PATENT SPECIFICATION**

(45) Date of publication and mention of the grant of the patent:  
**25.05.2011 Bulletin 2011/21**

(51) Int Cl.:  
**E04G 21/10<sup>(2006.01)</sup>**

(21) Application number: **05002192.2**

(22) Date of filing: **02.02.2005**

(54) **Portable vibratory screed with vibration restraint**

Bewegbarer Vibrationsstampfer mit Vibrationsbeschränkungssystem

Poutre égaliseuse vibratoire avec reducteur de vibrations

(84) Designated Contracting States:  
**AT BE BG CH CY CZ DE DK EE ES FI FR GB GR HU IE IS IT LI LT LU MC NL PL PT RO SE SI SK TR**

(72) Inventor: **Lutz, Todd J.**  
**Oconomowoc**  
**Wisconsin 53066 (US)**

(30) Priority: **04.02.2004 US 773012**

(74) Representative: **Müller - Hoffmann & Partner**  
**Patentanwälte**  
**Innere Wiener Strasse 17**  
**81667 München (DE)**

(43) Date of publication of application:  
**10.08.2005 Bulletin 2005/32**

(73) Proprietor: **Wacker Corporation**  
**Menomonee Falls,**  
**Wisconsin 53052 (US)**

(56) References cited:  
**US-A- 4 734 022 US-A- 5 857 803**  
**US-A- 5 984 571 US-B1- 6 296 467**

**EP 1 561 882 B1**

Note: Within nine months of the publication of the mention of the grant of the European patent in the European Patent Bulletin, any person may give notice to the European Patent Office of opposition to that patent, in accordance with the Implementing Regulations. Notice of opposition shall not be deemed to have been filed until the opposition fee has been paid. (Art. 99(1) European Patent Convention).

**Description**BACKGROUND OF THE INVENTION5 1. Field of the Invention

**[0001]** The invention relates to a portable vibratory screed machine, and, more particularly, relates to a portable vibratory screed machine having a vibration restraint configured to reduce undesirable vibrational wear on and extend the life of the machine's engine.

10

2. Discussion of the Related Art

**[0002]** Numerous screed machines employ vibratory action to tamp and smooth concrete in the strike off step of a concrete finishing operation. Known vibratory screed machines comprise, for instance, an elongated blade extending horizontally and transversally at lower ends of a pair of handles adapted to be hand held and operated for displacing the wet screed over a concrete surface. A motor is provided above the blade and between the handles. The motor's output extends to the blade, where it is connected to a vibratory assembly having one or more eccentric weights configured to impart vibrations to the screed blade upon motor operation. A handle permits an easy and constant correction of the level of the concrete with minimum effort. A throttle control is provided at the handle such that the speed of the motor may be adjusted as the blade is displaced over the concrete being surfaced.

15

20

25

**[0003]** One specific example of a known vibrating plate machine is disclosed in U.S. Pat. No. 4,340,351, which describes a vibratory concrete screed used in the final finishing of concrete. This screed requires two operators. As another example, U.S. Pat. No. 4,641,995 describes a vibratory concrete screed, which rides on forms to screed narrow strips of concrete, such as walks. This screed is mounted on the operator via a complicated harness counter-weighted frame and is powered by electricity. As a result, the screed requires electrical power, and the screed requires manipulation of lengthy extension cords. These and other screeds are designed to be used only after concrete has been leveled and preliminarily tamped. None of these screeds is suitable to "wet screed" large slabs of freshly poured concrete that has not yet been leveled or tamped at all.

30

35

**[0004]** In the absence of widely accepted wet screeding machines, the industry standard for wet screeding is to perform that process manually. Typically, in manual wet screeding, a 2-inch by 4-inch board (5.1 cm by 10.2 cm) that is 8-foot to 20-foot long (2.44 m to 6.096 m) is manipulated manually by one or two men hand working in conjunction with as many as four laborers, known as "puddlers," who push the fresh concrete in place with concrete rakes. The hand puddling and wet screeding process is slow, inefficient, labor intensive, and extremely fatiguing, particularly if large slabs are poured and finished over the course of an entire day or more. It is also often requires the addition of more water to the concrete mix to make it more workable. The addition of water to produce slumps of 6-inch to 8-inches (15.2 cm to 20.3 cm) is common in the industry to increase the workability of the concrete, allowing the finisher to effectively hand "wet screed" the fresh concrete. The hand process typically limits the finisher to the average pour of 6,000 to a maximum of 8,000 square feet (557 sqm to 743 sqm) of slab per day for crew of six. The additional water reduces the strength of the concrete, causing voids and weak spots in the cured concrete.

40

45

**[0005]** Proposals have been made to reduce the labor required for wet screeding by providing portable vibratory "wet screed" machines. These machines typically have an engine coupled to an drive shaft. The engine is generally an internal combustion engine having a housing, a fuel tank, a clutch housing, etc. The drive shaft is configured to drive a vibrator drive shaft of the vibratory assembly. The engine housing or a support therefore is secured to a housing for the vibrator drive shaft at one point by a clamp. The clamp location is approximately midway between a centroid of the engine and the blade. The clamp provides only limited restraint to the engine and drive shaft relative to the vibratory assembly along the x-y reference plane. Vibrations generated upon screed operation by the eccentric vibratory assembly therefore are transmitted to the clamp point and generate severe vibrations on the engine about all three (x, y, z) axes. The vibrations are known to cause failures not only in the clutch housing, but also of the handle assembly, the fuel tank, oil seals, the engine block, etc. Engine block failures are the most problematic because the engine is by far the most expensive component of the wet screed. The screed therefore is typically considered spent when the engine block fails. Vibratory wet screeds therefore historically have had a reputation of being unreliable, hindering their acceptance by the industry as a whole.

50

55

**[0006]** In US 6296467 B1, a vibrating screed for surfacing concrete is disclosed. The vibrating screed comprises a surfacing blade, a pair of handle assemblies mounted to said blade, a motor, a vibration causing mechanism and a transmission connected with a motor to the vibration causing mechanism. When the motor is in operation, it causes the transmission to rotate, the transmission being adapted to impart a vibratory motion to the blade. Each handle assembly comprises a main elongated tubular member and a handle mounted at a proximal end thereof. The handle includes a first tubular element mounted around the main tubular member, a second tubular element extending sidewise from the

first element and a third tubular element extending around the second element, with a grip member being mounted to the third element. The first element is capable of rotatable and translational displacement with respect to the main tubular member, and the third element and grip member are capable of rotational displacement relative to the second element. Clamps are provided for securing the first and third tubular elements in the selected positions.

5 [0007] In US 5984571 A, a vibrating screed is disclosed which permits selective adjustment of the angle between the axis of a rotatable eccentric and the plan define by the bottom of the screed plate. Thus, the relative vertical compaction and horizontal smoothing oscillation movement imparted by the eccentric can be varied. The screed further includes a frame, motor, an eccentric driven by the motor, a screed plate and a pair of locking hinges which releasably connect the frame to the screed plate in an angular relationship there between.

10 [0008] In light of the foregoing, a portable vibratory screed machine is desired with reduced undesirable vibration on the motor and expended motor life associated with operation of the vibratory screed machine in the surfacing of concrete.

SUMMARY OF THE INVENTION

15 [0009] This object is solved by a portable vibratory screed machine according to claim 1 and by a method for operating an engine of a vibratory plate machine according to claim 6.

[0010] The present invention provides an improved portable vibratory screed having a vibration restraint configured to reduce undesirable vibration on the engine and to extend the engine's life. The apparatus is ideally suited for use with wet screeds, but is usable with other vibratory screed machines as well.

20 [0011] In accordance with a first aspect of the invention, a portable vibratory screed machine includes a machine frame having a reference structure, an engine including a drive shaft and being mounted on the reference structure via a mount that surrounds the drive shaft, a vibratory assembly located remote from the engine, the vibratory assembly powered by the engine to vibrate, and a vibration restraint configured to restrain vibration of the engine. The vibration restraint directly couples the engine to the reference structure at a location that is spaced apart from the mount.

25 [0012] The resulting portable vibratory screed machine of the present invention has several advantages over prior vibratory plate machines. The vibratory plate does not interfere with or hinder normal operation of the portable vibratory screed machine. Further, the vibratory plate reduces the imposition of undesirable vibrations on the engine and thereby extends the engine life.

30 [0013] Furthermore, the present invention provides a method of extending a life of an engine having a drive shaft configured to drive a portable vibratory assembly. The engine is mounted on a reference structure of the portable vibratory screed machine. The method includes the acts of operating the engine to drive the vibratory assembly to generate vibrations, and restraining the engine relative to the vibratory assembly in a direction generally parallel to a central axis of the drive shaft. The act of restraining can include providing a restraint having a first end and a second end, coupling the first end of the restraint to the engine, and coupling the second end of the restraint to the reference structure.

35 [0014] Other features and advantages of the invention will become apparent to those skilled in the art from the following detailed description and accompanying drawings. It should be understood, however, that the detailed description and specific examples, while indicating the preferred embodiments of the present invention, are given by way of illustration and not of limitation. Many changes and modifications may be made within the scope of the present invention which is defined in the appended claims.

BRIEF DESCRIPTION OF THE DRAWINGS

40 [0015] Preferred exemplary embodiments of the invention are illustrated in the accompanying drawings in which like reference numerals represent like parts throughout, and in which:

- 45
- FIG. 1 is a perspective view of an assembled portable vibratory screed machine and vibration restraint in accordance with the present invention;
  - FIG. 2 is an exploded perspective view of the portable vibratory screed machine shown in FIG. 1;
  - FIG. 3 is a detailed perspective view of the portable vibratory screed machine shown in FIG. 1 illustrative of testing reference points for vibration restraint effectiveness;
  - 50 FIG. 4 is a detailed perspective view of the vibration restraint in FIG. 1;
  - FIG. 5 is a side view of the vibration restraint in FIG. 4;
  - FIG. 6 is a top view of the vibration restraint in FIG. 4; and
  - 55 FIG. 7 is a front view of the vibration restraint in FIG. 4.

DETAILED DESCRIPTION OF THE PREFERRED EMBODIMENTS

[0016] FIG. 1 illustrates a perspective view of a vibration restraint 20 constructed in accordance with one embodiment

of the invention and coupled to a portable vibratory wet screed machine 25. In general, the portable vibratory screed machine 25 includes an engine 30 mounted on a frame 35. The machine 25 further includes an elongated surfacing screed blade 45 coupled to a vibratory assembly 40. The engine 30 is operable to power the vibratory assembly 40 to impart vibratory movement to the blade 45 such that, when the blade 45 is maneuvered over a freshly poured (wet) concrete surface, the blade 45 is operable to provide a smooth, finished surface to the wet concrete. The vibratory screed machine 25 is controlled by an operator via a handle assembly 50 extending several feet from the frame 35. The handle assembly 50 includes a frame 58 connected to the frame 35 at its lower end and terminating at its upper end in the handgrips 60, and a kickstand 62 pivotally attached along the frame 58 to directly support a distal end 105 of the screed blade 45 on the ground.

**[0017]** A preferred engine 30 is a 4-stroke internal combustion engine of the type generally used for a portable vibratory screed machine. The engine 30 generally includes a housing or engine block 55, a crankcase 60, a fuel tank 65, a clutch housing 70, and a conventional air supply system (not shown). The clutch couples the engine output shaft (not shown) to a generally vertical drive shaft 80. The drive shaft 80, in turn, is coupled to an input shaft 82 of the vibratory assembly 40 by a flex joint 84 (Fig. 2). The engine 30 additionally includes an ignition system which, in the present example, comprises a manual pull starter 85. The engine 30 may be power by gasoline or other fuels.

**[0018]** The frame 35 includes a platform assembly 90 that is supported on the screed blade 45 by a blade adapter bracket assembly 130. The blade adapter bracket assembly 130 is attached to the bottom of platform assembly 90 by conventional fasteners 132 and is vibrationally separated from the frame 35 by vibrational isolators such as elastomeric shock mounts 135. The platform assembly 90 includes a mount plate 92 and a lift handle 94. The lift handle 94 includes an annular collar 98 and a grip 100 extending outwardly from the collar 98. The handle 94 is reversible so that the grip 100 can extend either forwardly of the screed as shown or rearward therefrom. The engine 30 is supported on the mount plate 92 via a lower frustoconical shaft housing 102 and a complimentary frustoconical base 104 of the clutch housing 70. The base 104 is attached to the upper end of the housing 102 by a clamp assembly 106.

**[0019]** The vibratory assembly 40 is preferably an eccentric mass assembly rotationally coupled to the drive shaft 80 by the above-described flex joint 84 and input shaft 82. The exciter assembly 40 may, for instance, comprise a set of adjustable eccentric weights and one or more fixed eccentric weights (not shown). The exciter assembly 40 is contained within an eccentric cover 120. The eccentric cover 120 is attached to the underside of the blade adjuster bracket assembly 130 in a conventional manner. A flexible sealing ring 124 prevents concrete, dirt, and other foreign materials from invading the interior of the vibratory assembly 40.

**[0020]** The screed blade 45 is generally L-shaped on cross sectional view, having a top surface, a finishing surface, a cutting edge, and trailing edge. Structural gussets 140 extend the length of the blade providing more uniform transmission of vibrational energy. Adapters may be employed to connect the blade adapter bracket assembly 130 to different shaped screed blades.

**[0021]** The engine 30 is restrained from vibration by the above-described vibration restraint 20, which provides additional support to the engine 30 beyond that provided by the clamp assembly 106. The vibration restraint 20 preferably couples the engine 30 to the frame 35. A preferred vibration restraint 20 includes a plate 150 generally shaped to conform to the contours of the vibratory screed machine. Specifically, as best seen in FIGS. 4-7, the plate 150 includes a first portion 155 aligned in a generally co-linear direction relative to a central axis 160 of the drive shaft 80, and a second portion 165 inclined with respect to the first portion 155 to conform to a narrower portion of the vibratory screed machine 25. The shape of the plate 150 (e.g., curvilinear, etc.) can vary. The plate 150 is preferably formed from steel, but could be formed from aluminum or another metal or another material entirely. The first portion 155 of the plate 150 terminates at a first, upper end 170, and the second portion 165 of the plate 150 terminates at a second, lower end 175. The first end 170 includes a pair of opening 180 configured to receive fasteners coupling the plate 155 to existing taps 185 in the engine housing 55. The second end 175 includes a flange portion 190 having a pair of openings 195 configured to receive fasteners coupling the plate 150 to the platform assembly 90. The flange 190 includes a curvilinear cutout portion 200 configured to receive a lower cylindrical end 205 of the shaft housing 102 (FIGS. 1 and 2). The types of fasteners (e.g., spot welds, etc.) can vary. The vibration restraint 20 preferably is attached to the engine housing 55 using existing taps 185 in the engine housing 65 and is attached to the platform assembly 90 using existing fasteners on the platform assembly 90. However, additional/and or other fasteners can be used apart from the illustrated fasteners. Structures supplementing or replacing the plate 150 could also be used as a vibrational restraint, so long as the structure(s) provide support for the engine 30 in addition to that provided by the clamp assembly 106.

**[0022]** The vibration restraint 20 is also configured to reduce undesirable vibration on clutch housing 70 and the engine 30 caused by vibrations from the eccentric movement of the vibratory assembly 40. Specifically, the plate 150 restrains vibration in a direction generally parallel to the central axis 160 of the drive shaft 80 but in a plane different from the drive shaft 80. The resultant load bearing triangulation and redundancy reduces the vibrational movement of the engine 30 and thereby enhances the engine's operating life.

**[0023]** In operation, an operator can initiate start-up of the engine 30 by either activating an automatic starter or pulling the manual pull starter system. 85. Clutch engagement causes the engine 30 to drive rotation of the drive shaft 80 at a

**EP 1 561 882 B1**

standard operating speed ranging from 4,000 to 8,000 rpm, but preferably in a standard operating range of 5,000 to 6,000 rpm. The rotating drive shaft 80 causes the flex coupling 84 and vibratory assembly input shaft 82 to rotate. The shaft 82 in turn drives rotation of the adjustable eccentric weights and the fixed eccentric weights of the vibratory assembly 40, thereby imparting vibrations to the bracket blade adapter assembly 130 and thus to the screed blade 45. The vibration isolators 135 reduce the magnitude of vibrations transmitted to the handle assembly 50 and the operator.

**[0024]** Engine speed and, hence, the frequency and intensity to the vibrations are controlled by a throttle control lever 210 attached to the handle assembly 50. The action of the throttle control lever 210 is transmitted to the engine 30. The vibrational force is transmitted through the blade adapter assembly 130 and along the screed blade 45, where structural gussets 140 strengthen blade 45 and apply the vibrational force evenly across the poured concrete.

**[0025]** The vibration restraint 20 of the portable vibratory screed machine 25 is operable to reduce undesirable vibration and associated wear and extends the engine life. This response is considered adequate for operating portable vibratory screed machines.

**[0026]** Tests indicate the vibration restraint 20 is operable to dramatically reduce the undesired vibration experienced by the engine 30. In these tests, movements of both the engine 30 and the mount plate 92 were measured along x, y, z reference points 215 and 220 at the engine 30 and at the mount plate 92 of the platform assembly 90, respectively. At an engine operating speed of 5,000 rpm (the low end of the standard operating speed of the disclosed wet screed), the results, measured in units of gravitation acceleration (g's), are reflected in Table 1:

Table 1: Vibration Reduction at 5,000 rpm

	STANDARD SCREED		SCREED w/VIBRATION RESTRAINT	
	ENGINE	BASE	ENGINE	BASE
X	2.2	1.9	2.7	2.0
Y	7.3	9.4	4.1	7.8
Z	7.5	2.8	3.1	4.0
SUM	10.7	10.0	5.8	9.0

**[0027]** At an engine operating speed of 6,000 rpm, the results measured in units of gravitation acceleration, are reflected in Table 2:

Table 1: Vibration Reduction at 6,000 rpm

	STANDARD SCREED		SCREED w/VIBRATION RESTRAINT	
	ENGINE	BASE	ENGINE	BASE
X	3.4	2.3	3.1	2.1
Y	5.6	7.0	4.0	6.3
Z	9.5	1.8	3.8	3.3
SUM	11.5	7.6	6.3	7.4

**[0028]** In reducing vibrational forces on the engine 30 and the clutch housing 70, the test results also show that the vibration restraint 20 is operable to increase the operating life of the engine 30 by a factor of two to eight times relative to the standard operating life of an engine of the same portable vibratory screed assembly without the vibration restraint 20. Tests were performed on portable vibratory wet screed machines configured as described above but lacking a vibration restraint and on corresponding portable vibratory wet screed machines having the vibration restraint 20. The engines were operated at a standard operating speed of 5,000 to 6,000 rpm, and the blades were submerged in foam and water to simulate concrete. The types of machines tested varied in length of screed blade (e.g., 6 foot to 10 foot i.e. 1.83 to 3.048 m) and varied settings of the exciter (i.e., half to full setting). The test results show that engines of a portable vibratory screed machines lacking a vibration restraint exhibit, on average, an operating life of 35 to 50 hours. In comparison, engines of corresponding portable vibratory screed machines having the vibration restraint 20 typically demonstrated operational lives of 175 to 400 hours or even more. Forty percent of the engines of the sampled machines exhibited operating lives that exceeded 200 hours. Several of the tests, exceeding 400 hours, ended without failures.

**[0029]** As indicated above, many changes and modifications may be made to the present invention without departing from the scope of the invention which is defined in the appended claims.

Claims

1. A portable vibratory screed machine (25), comprising:
  - (A) a screed blade (45);
  - (B) a machine frame (35) mounted on the screed blade;
  - (C) an engine (30) including a rotational output and an engine housing (55);
  - (D) a vibratory assembly (40) which is located remote from the engine and which impacts vibrations to the screed blade;
  - (E) a drive shaft (80) that transmits torque from the engine output to the vibratory assembly;
  - (F) an engine mount (102, 104, 90) that surrounds the drive shaft and that supports the engine on the machine frame;
  - (G) a reference structure (90) that is at least indirectly supported on the screed blade; **characterized in that:**
  - (H) a vibration restraint (20) is, attached to the engine housing and to the reference structure at a location that is spaced from the engine mount thereby to restrain the engine from vibrating in a direction that is at least generally parallel to a central axis of the drive shaft.
  
2. The portable vibratory screed machine of claim 1, wherein the reference structure (20) includes a mount plate (90) of the machine frame on which the engine mount is supported, and wherein the restraint has a first end (170) attached to the engine housing and a second end (175) terminating in a flange that is configured to receive fasteners coupling the flange to the mount plate.
  
3. The portable vibratory screed machine of claim 1, wherein the restraint comprises a plate (150) having first and second ends, the first end (170) being directly coupled to the engine housing and the second end (175) being directly coupled to the mount plate by the fasteners.
  
4. The portable vibratory screed machine of claim 3, wherein a portion of the plate is shaped to generally conform to a contour of a mating portion of the engine housing.
  
5. The portable vibratory screed machine of claim 1, wherein the vibration restraint (20) comprises a metal plate (90) having first portion (155) and a second portion (165), the first portion being inclined relative to the second portion, and a flange (190) coupled to the second portion and having openings configured to receive fasteners coupling the flange to the reference structure.
  
6. A method of operating an engine (30) of a vibratory plate machine, said engine (30) including a rotational output and an engine housing (55) the vibratory plate machine having a screed blade (45), a machine frame (35) mounted on the screed blade, a vibratory assembly (40), a drive shaft that couples the engine to the vibratory assembly, and an engine mount (102, 104) that surrounds the drive shaft and that supports the engine on the machine frame, the method comprising:
  - operating the engine to drive the vibratory assembly to generate vibrations that are imparted to the screed blade, and
  - characterized in that** during engine operation, the engine is restrained relative to the vibratory assembly in a direction generally parallel to a central axis of the drive shaft using a restraint (20) that is attached to the engine housing (55) and to a reference structure (90) that is supported at least indirectly on the screed blade and that is spaced from the engine mount.
  
7. The method of claim 6, wherein the act of restraining includes reducing vibrational movement of the engine by at least 40 percent relative to operating the same portable vibratory machine without performing the act of restraining.
  
8. The method of claim 6, wherein the act of restraining includes providing a restraint (20) having a first end (120) and a second end (175), coupling the first end of the restraint to the engine, and coupling the second end of the restraint to the reference structure.
  
9. The portable vibratory screed machine of claim 1, wherein the reference structure (90) is part of the machine frame (35).
  
10. The portable vibratory screed machine of claim 1, further comprising a handle assembly (50) that is mounted on

the machine frame.

11. The method of claim 6, wherein the reference structure (90) is part of the machine frame (35).

5 12. The method of claim 11, further comprising guiding the portable screed assembly using a handle assembly mounted on the machine frame (35).

10 13. The portable vibratory screed machine according to claim 1, wherein the drive shaft (80) extends at least generally vertically; the engine mount (102, 104) extends at least generally vertically upwardly from the machine frame and is clamped to the engine; the reference structure (90) is spaced from a base of the engine mount.

15 **Patentansprüche**

1. Tragbare Vibrationsglättmaschine (25), mit:

- (A) einem Glättblatt (45);
- 20 (B) einem Maschinenrahmen (35), der an dem Glättblatt montiert ist;
- (C) einem Motor (30), der einen Drehausgang und ein Motorgehäuse (55) enthält;
- (D) einer Vibrationsanordnung (40), die sich entfernt vom Motor befindet und das Glättblatt mit Vibrationen beaufschlagt;
- (E) einer Antriebswelle (80), die Drehmoment von dem Motorausgang zu der Vibrationsanordnung überträgt;
- 25 (F) einer Motorhalterung (102, 104, 90), die die Antriebswelle umgibt und den Motor an dem Maschinenrahmen unterstützt;
- (G) einer Referenzstruktur (90), die zumindest indirekt an dem Glättblatt unterstützt ist;
- dadurch gekennzeichnet, dass:**
- (H) eine Vibrationsbegrenzungseinrichtung (20) an dem Motorgehäuse und an der Referenzstruktur an einem
- 30 Ort befestigt ist, der von der Motorhalterung beabstandet ist, um **dadurch** eine Vibration des Motors in einer Richtung, die zumindest im Allgemeinen zu der Mittelachse der Antriebswelle parallel ist, zu beschränken.

2. Tragbare Vibrationsglättmaschine nach Anspruch 1, wobei die Referenzstruktur (20) eine Halterungsplatte (90) des Maschinenrahmens aufweist, auf der die Motorhalterung unterstützt ist, und wobei die Begrenzungseinrichtung ein erstes Ende (170) besitzt, das an dem Motorgehäuse befestigt ist, und ein zweites Ende (175) besitzt, das in einem Flansch endet, der konfiguriert ist, um Befestigungseinrichtungen aufzunehmen, die den Flansch mit der Halterungsplatte koppeln.

3. Tragbare Vibrationsglättmaschine nach Anspruch 1, wobei die Begrenzungseinrichtung eine Platte (150) mit einem ersten und einem zweiten Ende aufweist, wobei das erste Ende (170) mit dem Motorgehäuse direkt gekoppelt ist und das zweite Ende (175) mit der Halterungsplatte durch die Befestigungseinrichtungen direkt gekoppelt ist.

4. Tragbare Vibrationsglättmaschine nach Anspruch 3, wobei ein Abschnitt der Platte so geformt ist, dass er im Allgemeinen mit einem Umriss eines Passabschnitts des Motorgehäuses übereinstimmt.

5. Tragbare Vibrationsglättmaschine nach Anspruch 1, wobei die Vibrationsbegrenzungseinrichtung (20) eine Metallplatte (90) mit einem ersten Abschnitt (155) und einem zweiten Abschnitt (165) aufweist, wobei der erste Abschnitt in Bezug auf den zweiten Abschnitt geneigt ist, und einen Flansch (190) aufweist, der mit dem zweiten Abschnitt gekoppelt ist und Öffnungen besitzt, die konfiguriert sind, um die Befestigungseinrichtungen, die den Flansch mit der Referenzstruktur koppeln, aufzunehmen.

6. Verfahren zum Betreiben eines Motors (30) einer Vibrationsplattenmaschine, wobei der Motor (30) einen Drehausgang und ein Motorgehäuse (55) aufweist, wobei die Vibrationsplattenmaschine ein Glättblatt (45), einen Maschinenrahmen (35), der an dem Glättblatt montiert ist, eine Vibrationsanordnung (40), eine Antriebswelle, die den Motor mit der Vibrationsanordnung koppelt, und eine Motorhalterung (102, 104), die die Antriebswelle umgibt und den Motor an dem Maschinenrahmen unterstützt, besitzt, wobei das Verfahren enthält:

## EP 1 561 882 B1

Betreiben des Motors, um die Vibrationsanordnung anzutreiben, um Vibrationen zu erzeugen, mit denen das Glättblatt beaufschlagt wird, und

**dadurch gekennzeichnet, dass** während des Motorbetriebs

der Motors hinsichtlich seiner Bewegung relativ zu der Vibrationsanordnung in einer Richtung, die zu einer Mittelachse der Antriebswelle im Allgemeinen parallel ist, unter Verwendung einer Begrenzungseinrichtung (20), die an dem Motorgehäuse (55) und an einer Referenzstruktur (90) befestigt ist, die zumindest indirekt auf dem Glättblatt unterstützt ist und von der Motorhalterung beabstandet ist, begrenzt wird.

7. Verfahren nach Anspruch 6, wobei der Begrenzungsvorgang das Verringern einer Vibrationsbewegung der Maschine um wenigstens 40 Prozent relativ zum Betrieb derselben tragbaren Vibrationsmaschine ohne Ausführung des Begrenzungsvorgangs enthält.

8. Verfahren nach Anspruch 6, wobei der Begrenzungsvorgang enthält:

Vorsehen einer Begrenzungseinrichtung (20), die ein erstes Ende (120) und ein zweites Ende (175) besitzt, Koppeln des ersten Endes der Begrenzungseinrichtung mit dem Motor und Koppeln des zweiten Endes der Begrenzungseinrichtung mit der Referenzstruktur.

9. Tragbare Vibrationsglättmaschine nach Anspruch 1, wobei die Referenzstruktur (90) ein Teil des Maschinenrahmens (35) ist.

10. Tragbare Vibrationsglättmaschine nach Anspruch 1, ferner mit einer Griffanordnung (50), die an dem Maschinenrahmen montiert ist.

11. Verfahren nach Anspruch 6, wobei die Referenzstruktur (90) ein Teil des Maschinenrahmens (35) ist.

12. Verfahren nach Anspruch 11, das ferner das Führen der tragbaren Glättanordnung unter Verwendung einer Griffanordnung, die an dem Maschinenrahmen (35) montiert ist, enthält.

13. Tragbare Vibrationsglättmaschine nach Anspruch 1, wobei die Antriebswelle (80) wenigstens im Allgemeinen vertikal verläuft; die Motorhalterung (102, 104) wenigstens im Allgemeinen von dem Maschinenrahmen vertikal nach oben verläuft und am Motor festgeklemmt ist; die Referenzstruktur (90) von einer Basis der Motorhalterung beabstandet ist.

### Revendications

1. Machine à poutre égaliseuse vibrante portative (25) comprenant :

(A) une lame égaliseuse (45) ;

(B) un châssis de machine (35) qui est monté sur la lame égaliseuse ;

(C) un moteur (30) qui comprend un organe de sortie rotatif et un carter de moteur (55) ;

(D) un ensemble vibrant (40) qui est placé loin du moteur et qui communique des vibrations à la lame égaliseuse ;

(E) un arbre d'entraînement (80) qui transmet un couple de l'organe de sortie du moteur à l'ensemble vibrant ;

(F) un montage de moteur (102, 104, 90) qui entoure l'arbre d'entraînement et qui supporte le moteur sur le châssis de machine ;

(G) une structure de référence (90) qui est supportée au moins indirectement sur la lame égaliseuse ;

**caractérisée en ce que**

(H) un limiteur de vibrations (20) est fixé au carter de moteur et à la structure de référence à un endroit espacé du montage de moteur, pour empêcher ainsi le moteur de vibrer dans un sens qui est au moins globalement parallèle à un axe central de l'arbre d'entraînement.

2. Machine à poutre égaliseuse vibrante portative de la revendication 1, dans laquelle la structure de référence (20) comprend une plaque de montage (90) du châssis de machine, sur laquelle est supporté le montage de moteur, et dans laquelle le limiteur a une première extrémité (170) fixée au carter de moteur et une seconde extrémité (175) qui se termine par un rebord conçu pour recevoir des pièces de fixation qui relient ledit rebord à la plaque de montage.

## EP 1 561 882 B1

3. Machine à poutre égaliseuse vibrante portative de la revendication 1, dans laquelle le limiteur comprend une plaque (150) qui a des première et seconde extrémités, la première extrémité (170) étant directement reliée au carter de moteur et la seconde extrémité (175) étant directement reliée à la plaque de montage par les pièces de fixation.
- 5 4. Machine à poutre égaliseuse vibrante portative de la revendication 3, dans laquelle une partie de la plaque est formée pour correspondre globalement à un contour d'une partie correspondante du carter de moteur.
- 10 5. Machine à poutre égaliseuse vibrante portative de la revendication 1, dans laquelle le limiteur de vibrations (20) comprend une plaque en métal (90) qui a une première partie (155) et une seconde partie (165), la première partie étant inclinée par rapport à la seconde partie, et un rebord (190) qui est relié à la seconde partie et qui a des ouvertures conçues pour recevoir des pièces de fixation reliant le rebord à la structure de référence.
- 15 6. Procédé pour faire fonctionner un moteur (30) d'une machine à plaque vibrante, ledit moteur (30) comprenant un organe de sortie rotatif et un carter de moteur (55), la machine à plaque vibrante ayant une lame égaliseuse (45), un châssis de machine (35) monté sur la lame égaliseuse, un ensemble vibrant (40), un arbre d'entraînement qui relie le moteur à l'ensemble vibrant, et un montage de moteur (102, 104) qui entoure l'arbre d'entraînement et qui supporte le moteur sur le châssis de machine, le procédé comprenant :
- 20 le fait de faire fonctionner le moteur pour entraîner l'ensemble vibrant afin de produire des vibrations qui sont communiquées à la lame égaliseuse, et
- caractérisé en ce que** pendant le fonctionnement du moteur, le moteur est retenu par rapport à l'ensemble vibrant dans un sens globalement parallèle à un axe central de l'arbre d'entraînement, à l'aide d'un limiteur (20) qui est fixé au carter de moteur (55) et à une structure de référence (90) supportée au moins indirectement sur la lame égaliseuse et espacée du montage de moteur.
- 25 7. Procédé de la revendication 6, selon lequel l'action de retenue comprend la limitation du mouvement vibratoire du moteur d'au moins 40 pour cent par rapport au fonctionnement de la même machine vibrante portative sans action de retenue.
- 30 8. Procédé de la revendication 6, selon lequel l'action de retenue comprend le fait de prévoir un organe de limitation (20) qui a une première extrémité (120) et une seconde extrémité (175), de relier la première extrémité de l'organe de limitation au moteur, et de relier la seconde extrémité de l'organe de limitation à la structure de référence.
- 35 9. Machine à poutre égaliseuse vibrante portative de la revendication 1, dans laquelle la structure de référence (90) fait partie du châssis de machine (35).
- 40 10. Machine à poutre égaliseuse vibrante portative de la revendication 1, comprenant par ailleurs un ensemble formant poignée (50) qui est monté sur le châssis de machine.
- 45 11. Procédé de la revendication 6, selon lequel la structure de référence (90) fait partie du châssis de machine (35).
12. Procédé de la revendication 11, comprenant par ailleurs le guidage de l'ensemble égaliseur portatif à l'aide d'un ensemble formant poignée monté sur le châssis de machine (35).
- 50 13. Machine à poutre égaliseuse vibrante portative de la revendication 1, dans laquelle l'arbre d'entraînement (80) s'étend au moins globalement à la verticale ; le montage de moteur (102, 104) s'étend au moins globalement à la verticale vers le haut à partir du châssis de machine, et est fixé par serrage au moteur ; la structure de référence (90) est espacée d'une base du montage de moteur.

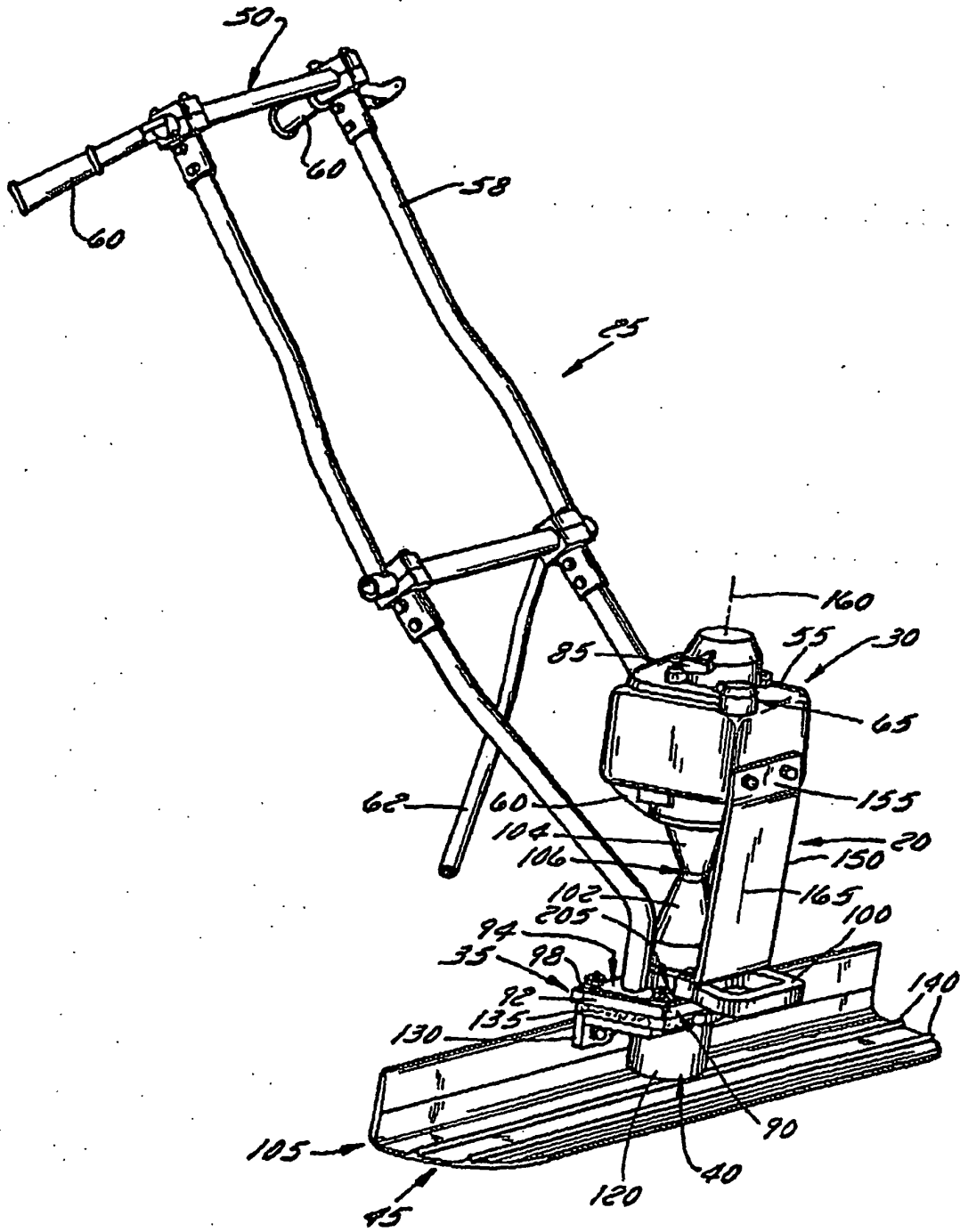

FIG. 1

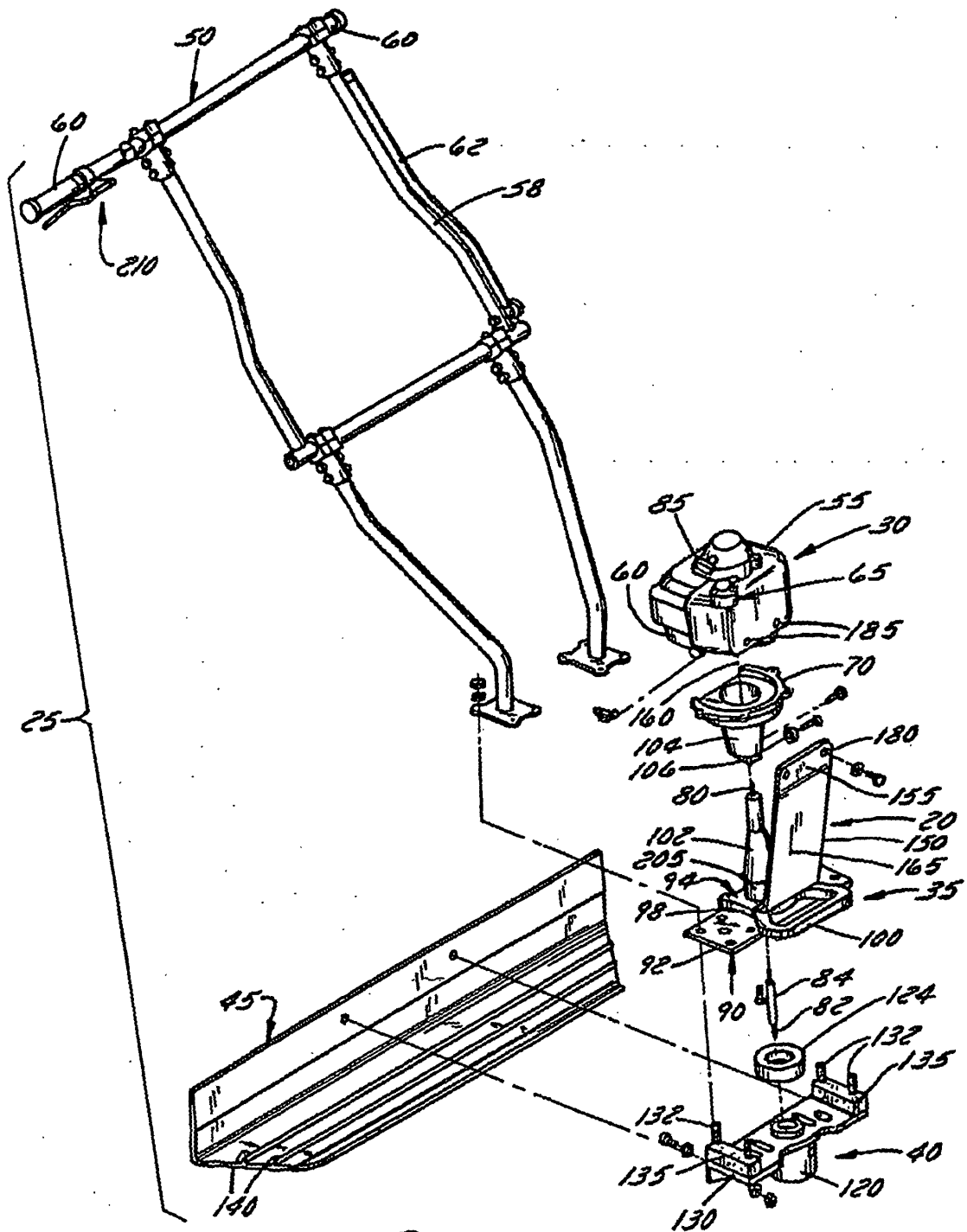

FIG. 2

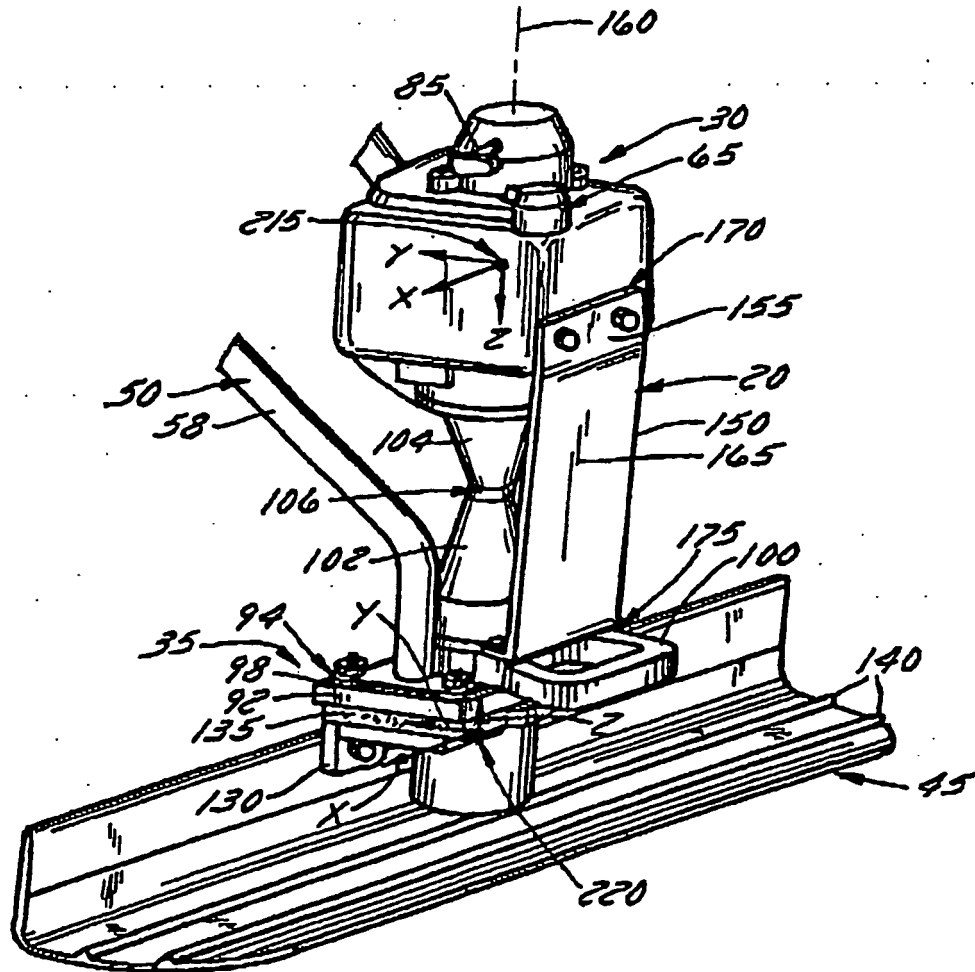

FIG. 3

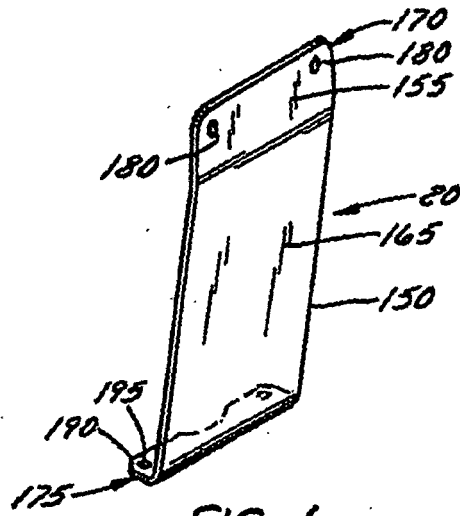

FIG. 4

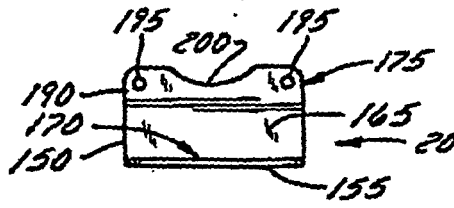

FIG. 6

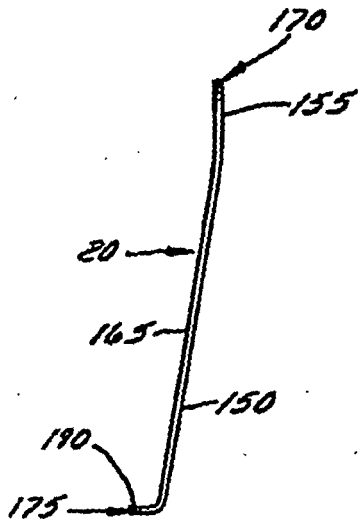

FIG. 5

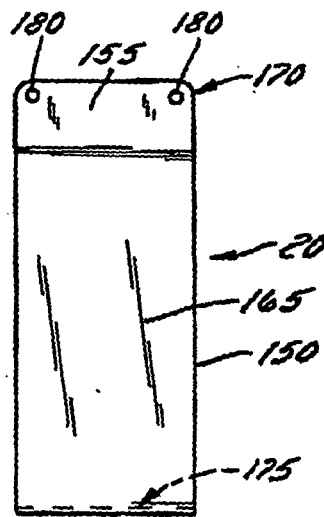

FIG. 7

**REFERENCES CITED IN THE DESCRIPTION**

*This list of references cited by the applicant is for the reader's convenience only. It does not form part of the European patent document. Even though great care has been taken in compiling the references, errors or omissions cannot be excluded and the EPO disclaims all liability in this regard.*

**Patent documents cited in the description**

- US 4340351 A [0003]
- US 4641995 A [0003]
- US 6296467 B1 [0006]
- US 5984571 A [0007]