

(19) World Intellectual Property Organization
International Bureau



(43) International Publication Date
28 August 2008 (28.08.2008)

PCT

(10) International Publication Number
WO 2008/102403 A2

- (51) International Patent Classification:
G06Q 20/00 (2006.01)
- (21) International Application Number:
PCT/IT2008/000106
- (22) International Filing Date:
19 February 2008 (19.02.2008)
- (25) Filing Language: English
- (26) Publication Language: English
- (30) Priority Data:
BA2007A000015 21 February 2007 (21.02.2007) IT
- (71) Applicant (for all designated States except US): NETDIG-
ITALSYSTEM di [IT/IT]; Galella Francesco S.a.s., Via
Principe di Savoia n. 21, I-73100 LECCE (IT).
- (72) Inventor; and
- (75) Inventor/Applicant (for US only): GALELLA,
Francesco [IT/IT]; Via Principe di Savoia n. 21, I-73100
LECCE (IT).
- (74) Agent: BRUNI, Giovanni; Laforgia, Bruni & Partners,
Corso Duca degli Abruzzi No.78, I-10129 Torino (IT).

- (81) Designated States (unless otherwise indicated, for every
kind of national protection available): AE, AG, AL, AM,
AO, AT, AU, AZ, BA, BB, BG, BH, BR, BW, BY, BZ, CA,
CH, CN, CO, CR, CU, CZ, DE, DK, DM, DO, DZ, EC, EE,
EG, ES, FI, GB, GD, GE, GH, GM, GT, HN, HR, HU, ID,
IL, IN, IS, JP, KE, KG, KM, KN, KP, KR, KZ, LA, LC,
LK, LR, LS, LT, LU, LY, MA, MD, ME, MG, MK, MN,
MW, MX, MY, MZ, NA, NG, NI, NO, NZ, OM, PG, PH,
PL, PT, RO, RS, RU, SC, SD, SE, SG, SK, SL, SM, SV,
SY, TJ, TM, TN, TR, TT, TZ, UA, UG, US, UZ, VC, VN,
ZA, ZM, ZW.
- (84) Designated States (unless otherwise indicated, for every
kind of regional protection available): ARIPO (BW, GH,
GM, KE, LS, MW, MZ, NA, SD, SL, SZ, TZ, UG, ZM,
ZW), Eurasian (AM, AZ, BY, KG, KZ, MD, RU, TJ, TM),
European (AT, BE, BG, CH, CY, CZ, DE, DK, EE, ES, FI,
FR, GB, GR, HR, HU, IE, IS, IT, LT, LU, LV, MC, MT, NL,
NO, PL, PT, RO, SE, SI, SK, TR), OAPI (BF, BJ, CF, CG,
CI, CM, GA, GN, GQ, GW, ML, MR, NE, SN, TD, TG).

[Continued on next page]

(54) Title: ELECTRONIC BEACH UMBRELLA SYSTEM

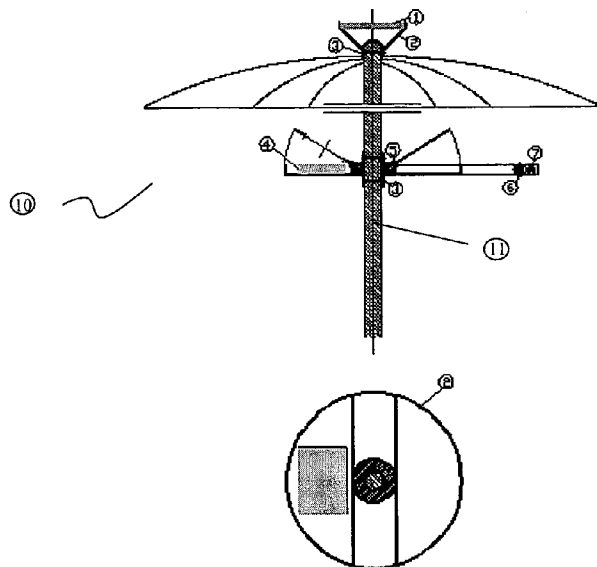

Fig. 1

(57) Abstract: Electronic beach umbrella system for use at bathing establishments, solariums, hotel and private structures, characterised by computerised terminals connected via wireless network with a central node and equipped with power supply by means of alternative energy, for example solar energy.

WO 2008/102403 A2



Published:

- *without international search report and to be republished upon receipt of that report*

Electronic beach umbrella system

DESCRIPTION

The present finding is a system of "intelligent" electronic beach
5 umbrellas that permits accomplishing a series of operations
linked to the needs both of operators of bathing-tourism
establishments and the clientele. In other words, the beach
umbrella product becomes an electronic system for general
interactivity.

10 Embodiments of similar products are not known at the state of
the art, but only several inventions are known pertaining to the
object of the present finding but do not nullify its novelty and
inventive activity requirements. In fact, the European patent
application EP00854459 describes a beach umbrella equipped
15 with a refrigerator storage unit, supplied by means of non-
conventional energy, for example photovoltaic solar energy, and
electronically controlled. The European patent application
EP01354533, on the other hand, illustrates a beach umbrella that
comprises a radio system comprising loudspeakers, supplied
20 with a photovoltaic system. The beach umbrella can also be used
in a conventional manner. The loudspeakers are positioned
below the cloth, the electronic circuit inside the tubular part, and
the photovoltaic cells above the textile cover. The USA
application US26124157, finally, describes beach umbrellas for
25 bathing use having a housing for electric/electronic devices

including an electronic safe and the related control panel. The power supply is preferably obtained by solar energy conversion.

As is seen, even by combining several of the state of the art teachings, one does not arrive at a solution for creating a system of general interactivity in bathing establishments, beaches, parks, etc.

The finding of the present invention, resolves the above mentioned technical problem since it involves a system of electronic beach umbrellas for use at bathing establishments, solariums, hotel and private structures, characterised by a plurality of computerised terminals connected via wireless network with a central node and in that each beach umbrella is equipped with an independent power supply by means of alternative energy, for example solar energy.

These and other advantages will be evident from the detailed description of the invention, with specific reference to the table 1/1 in which a preferential, strictly non-limiting embodiment is represented.

With reference to Figure 1, a generic beach umbrella is indicated with 10, called electronic or intelligent since it permits accomplishing the management needs both of bathing-tourism establishment operators and the clientele. It is made up of the following additional components: a photovoltaic element 1, for the system power supply, provided with a support structure 2 and connection pin 3 to the traditional pole 11 of the beach umbrella

and a computerised terminal 4, connected with said pole by means of appropriate hinges 5 or other connection members, provided with appropriate electric outlets 6 and telematic connections 7, for example USB ports. Naturally, alternatively to the computerised terminal with which the beach umbrella is provided, it is possible to use any external terminal (laptop, palmtop, Smartphone or the like) as long as it is provided with wireless technology. All terminals of the beach umbrellas communicate with a cashier terminal which manages them; in fact, it acts as an actual server of a wireless LAN network whose terminals (clients) are represented by the beach umbrellas.

The client-server connection is preferably based on Wi-Fi technology (by radio waves) through the use of Access-Points of IEEE 802.11 type which can usually communicate with 30 clients situated within a range of 100 m. In order to increase the transmission distance and to cover more extensive zones, such as those constituting bathing establishments and similar areas, "bridge mode" Access-Points can be used, that is repeaters of the Wi-Fi signal. Naturally, other types of wireless connection are not excluded, such as for example Blue Tooth, infrared radiation, laser systems and the like. All of the transmissions (client-server, client-client) are encrypted by using the protocol WPA2 (IEEE 802.11i), so to ensure high communication security. In particular, each client element positioned on the single umbrellas

will be identified through the hardware address of the wireless network card. Other types of security are not excluded.

The clientele will be able to use the system for:

- 5 • viewing on a display the menu/list of the products/services offered by the facility, without having to actually go to the sales or distribution counters;
- carrying out orders of the aforesaid products, that is requesting the offered services through the functionalities of the aforesaid intelligent umbrella;
- 10 • communicating in real time with the “cashier” station, or with other surrounding beach umbrellas by means of instant messaging;
- accessing the Internet in order to communicate, listen to music, search for information, and anything else that is
15 available on-line.

On the other hand, the manager of the facility will be able to:

- manage all of the orders in an automated manner;
- manage the stock in an automated manner;
- directly communicate with the user regarding possible
20 promotions on new products and/or services;
- constantly monitor his own market;
- increase the sales of products/services thanks to the user-friendly interface of the system.

That described above is made possible by the hardware and
25 software instrumentation making up the beach umbrellas and the

cashier terminal that manages them. Each umbrella, therefore, must be equipped with:

- touchscreen tablet PC with wireless technology (Wi-Fi and Bluetooth), on which a client version software is installed with similar characteristics to those used for managing orders in pubs and restaurants;
- photovoltaic element for the power supply.

In the case of external computerised terminal, i.e. not incorporated in the umbrella, the user will have to register his mobile device at the cashier/terminal so that his own laptop or Smartphone or palmtop is temporarily associated with one of the intelligent beach umbrellas prearranged to supply the service. In practice, the mobile device, once authenticated on the server and unequivocally associated with an intelligent beach umbrella, will be authorised to carry out orders that will be added to the single bill of the reference beach umbrella.

In addition, the automated management of orders and stock can be for example achieved by means of integration of the intelligent umbrella system with a POS (Point of Sale) system and an ERP (Enterprise Resource Planning) system. Such integration would consist of installing a POS system for the sales directed to the counter and of maintaining synchronised on an ERP system all of the sales and orders coming from both the POS system and from the intelligent umbrellas. Alternatively, one could install a POS system that takes both the orders coming

from the intelligent umbrellas and the sales directed to the counter and then synchronises all the data on the ERP system. The ERP system would therefore permit knowing in real time the exact amount of the stock supply, planning optimal supply strategies, calculating purchasing trends and identifying the most profitable clients. The entire system described up to now (Intranet management of the orders, ERP, POS) can in turn be integrated/synchronised with a web application (Internet) through which the administrator of the bathing establishment/restaurant/bar/pub can show (advertising) his own baths and simultaneously manage the on-line (remote) reservation of the offered services (beach umbrella reservation, number of seats, other offered services) with payment carried out through the application itself (on-line payment).

The overall design of the beach umbrella illustrates the fact that the components of the system are intended to be easily adaptable for the most common beach umbrellas already existing on the market. The achievement *ex novo* of the entire apparatus should not be intended as excluded, however, such apparatus in any case being easy to assemble as well as disassemble for the related storage.

By providing Internet connection, the user from home will also have the possibility to reserve the beach umbrella under which he will pass an enjoyable day by the sea, at a privileged position, without risking arriving on the beach and not finding any place

available. The reservation can be made by means of the use of credit card, on which also the subsequent purchases carried out under the beach umbrella can be charged.

CLAIMS

- 1) Electronic beach umbrella system for use at bathing establishments, solariums, hotel and private structures, characterised by a plurality of computerised terminals, localised at said beach umbrellas and connected via wireless network with a central node, and in that each beach umbrella is equipped with independent power supply by means of alternative energy.
- 2) System according to claim 1, characterised in that said central node is a cashier terminal that manages all the terminals of the beach umbrellas (clients), operating as a server of a wireless LAN network.
- 3) System according to claim 1 or 2, where the wireless communication is based on Wi-Fi technology, for radio waves, through the use of Access-Points of IEEE 802.11 type.
- 4) System according to claim 3, where said Access-Points are used in "bridge mode".
- 5) System according to claim 1 or 2, where the wireless communication is based on Blue Tooth technology or on infrared radiation or on laser systems or the like.
- 6) System according to one of the claims from 2 - 5, characterised in that all the transmissions (client-server, client-client) are encrypted.

- 7) System according to claim 6, where said data transmissions are encrypted by using the protocol WPA2 (IEEE 802.11i).
- 8) System according to one of the preceding claims, characterised in that said alternative energy that provides the power supply to each beach umbrella is of photovoltaic solar type.
- 9) System according to one of the preceding claims, characterised in that it integrates a POS (Point of Sale) system for the management of the sales, directed to the counter and/or by means of client terminals, and an ERP (Enterprise Resource Planning) system for the management and synchronisation of the orders.
- 10) System according to any one of the preceding claims, characterised in that it integrates a web application (Internet) for advertising use and/or for the on-line management of the reservations and/or payments.
- 11) Use of a beach umbrella system, as described in claims 1 - 10, by clients for viewing on a display the menu/list of products/services offered by the structure, making orders of the aforesaid products or requesting the offered services, communicating in real time with the "cashier" station or with other surrounding beach umbrellas by means of instant messaging, accessing the Internet.
- 12) Use of a beach umbrella system, as described in claims 1 - 10, by the manager of the structure for managing all the

orders and the stock in an automated manner, for communicating promotions on new products and/or services, for supplying products/services.

- 5 13) Electronic beach umbrella (10) for a system, as described in claims 1 - 8, characterised by a photovoltaic element (1), provided with support structure (2) and connection means (3) to the pole (11) of the beach umbrella, and by a computerised terminal (4), connected to said pole by means of suitable connection members (5) and provided with power supplies
10 (6) and telematic connections (7).
- 14) Electronic beach umbrella according to claim 13, where said computerised terminal (4) is equipped with wireless technology and client version software.
- 15 15) Electronic beach umbrella according to claim 13, where said computerised terminal (4) is an external and mobile terminal (laptop, palmtop, Smartphone or the like) unequivocally associated with said intelligent beach umbrella.
- 20 16) Integration module for a commercial beach umbrella as described in claims 13 and 14, characterised by a photovoltaic element (1), provided with support structure (2) and connection means (3) to the pole (11) of the beach umbrella, and by a computerised terminal (4), connected to said pole by means of appropriate connection members (5), equipped with power supplies (6) and telematic connections

(7), said components being easily adaptable for the beach umbrellas already found on the market.

17) Module according to claim 15, where said components can be easily assembled and disassembled for the related storage.

5

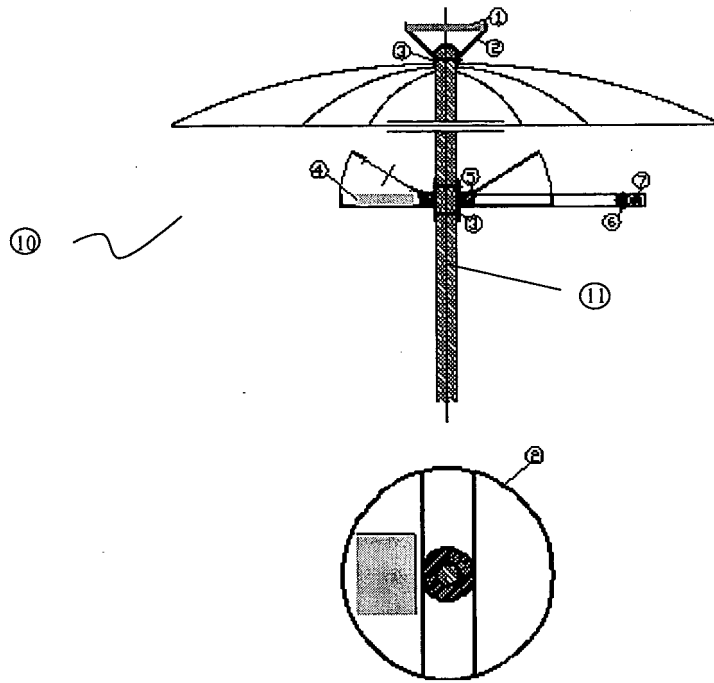

Fig. 1