

E. Fitzhenry, Dressing Leather.

No. 100,387.

Patented Mar. 1. 1870.

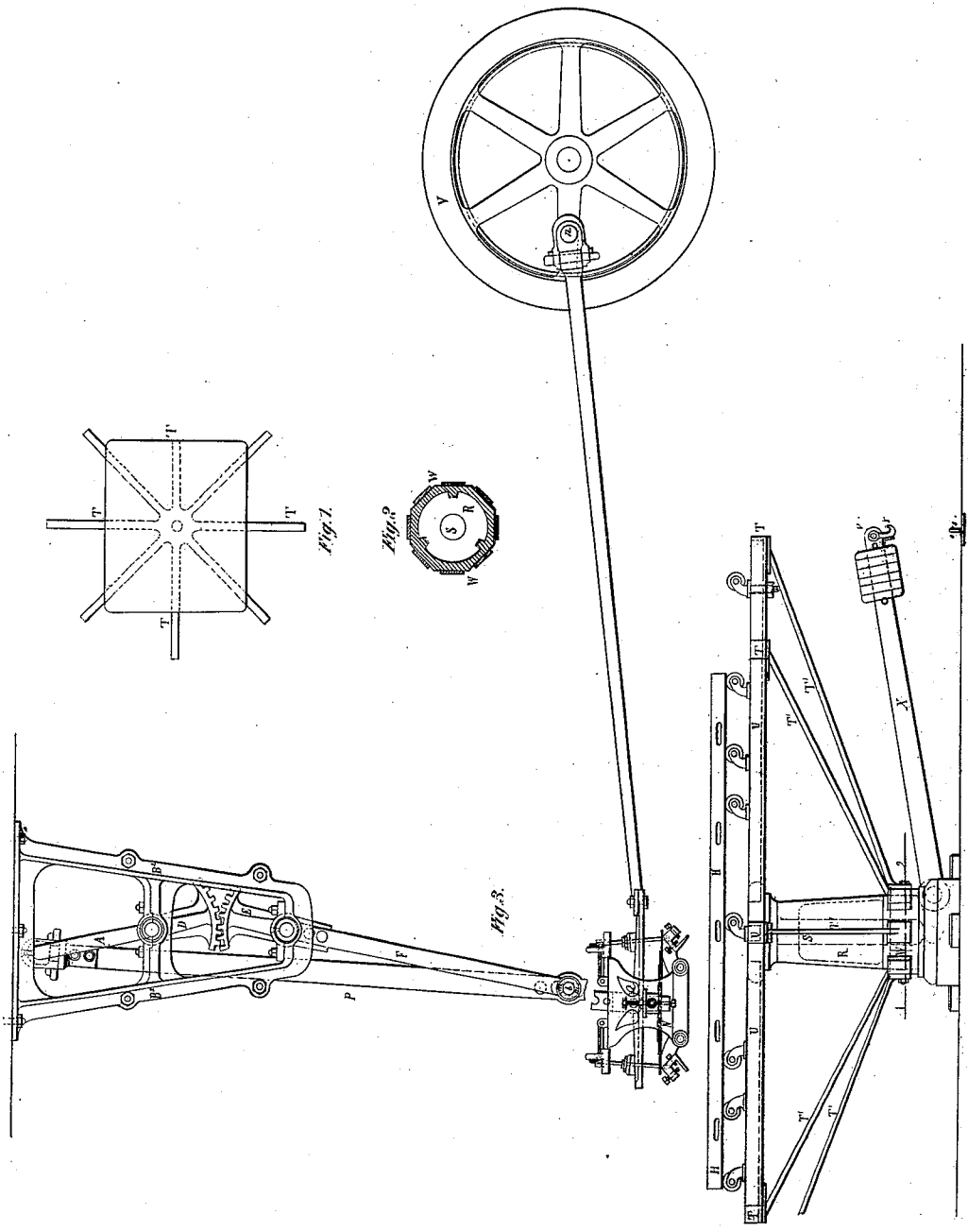

Samuel McKean

Inventor:
Edward Fitzhenry

2, Sheets, Sheet 2.
E. Fitzhenry,
Dressing Leather.
 No. 100,387. Patented Mar. 1. 1870.

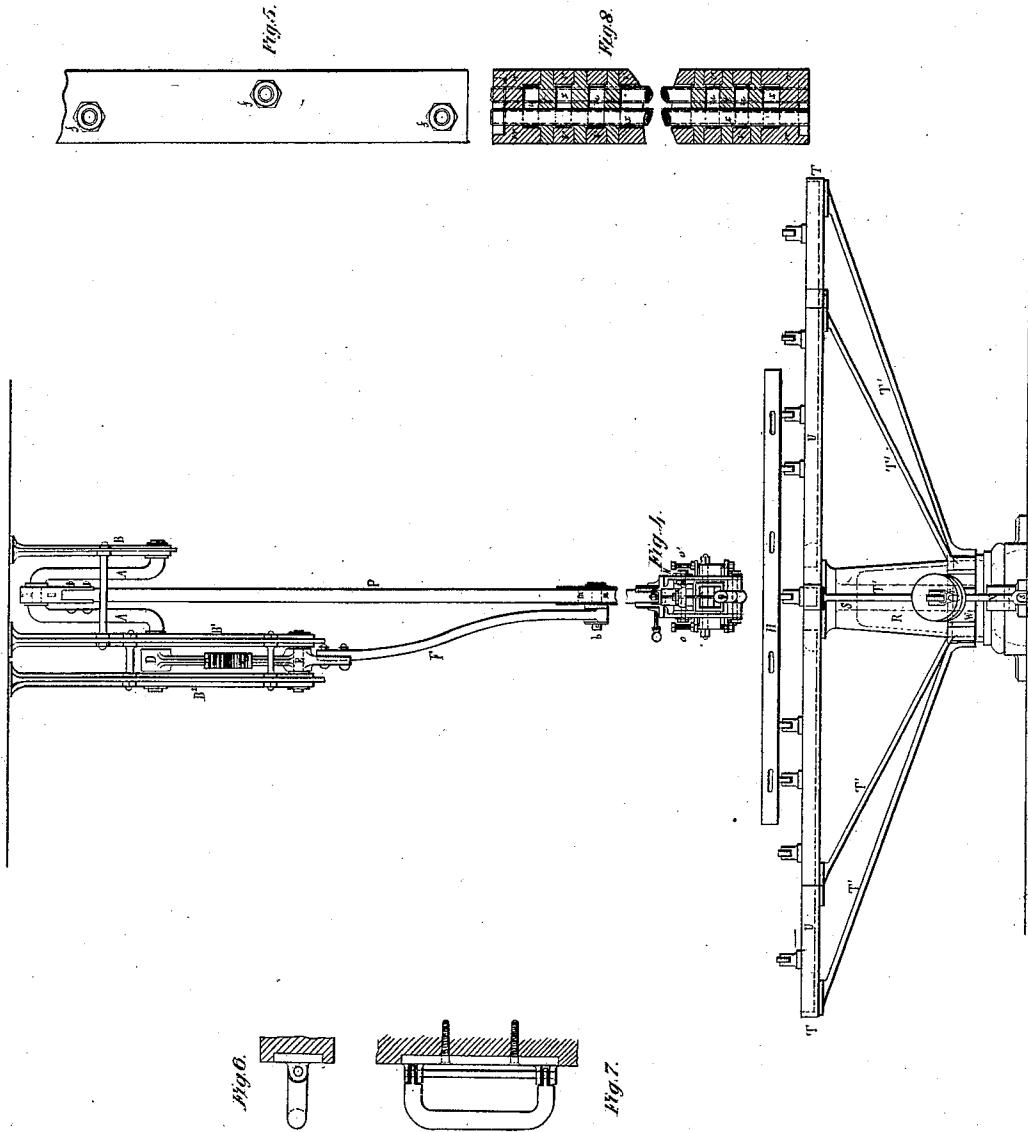

Witnessed
J. A. McKean

Inventor
E. Fitzhenry

United States Patent Office.

EDWARD FITZHENRY, OF BOSTON, MASSACHUSETTS.

Letters Patent No. 100,387, dated March 1, 1870.

IMPROVEMENT IN MACHINES FOR DRESSING LEATHER.

The Schedule referred to in these Letters Patent and making part of the same

To all persons to whom these presents may come:

Be it known that I, EDWARD FITZHENRY, of Boston, in the county of Suffolk, and State of Massachusetts, have invented certain new and useful Improvements in Machinery for Dressing, Setting Out, or Preparing Skins or Leather; and I do hereby declare the following to be a full and complete description thereof, reference being had to the accompanying-drawings making part thereof.

My improvements relate to mechanism for giving motion to the tool-carriage of the machine, also to the bed or table and the supports thereof.

Of the said drawings—

Figure 1 is a plan indicative of the arrangement of the arms of the table-supporters;

Figure 2 is a horizontal section taken on the line 1 2 of fig. 3, and through the collar W, for connecting the arms or braces T T of the radial arms of the table-supporter;

Figure 3 is a side elevation of the machine;

Figure 4 is an end view of it with the exception of certain parts, viz: the fly-wheel and connecting-rod thereof;

Figure 5 is an edge elevation; and

Figure 8, a transverse section of the table.

Figures 6 and 7 are illustrations of one of the handles of the table.

With respect to the mechanism for operating the tool-carriage, shown at N, in the drawings, instead of supporting such carriage by means of horizontal rails or ways, such as ordinarily employed, which are objectionable on some accounts, I joint the said carriage to the lower part of a furcated pendulous-rod, P, made of suitable material.

Were the upper joint of this rod supported by a stationary bearing, its lower extremity or part Q, which is jointed to the tool-carriage, would describe the arc of a circle during a vibratory movement of the rod, and of course the tool-carriage would be correspondingly moved.

It being desirable to have the tool-carriage moved in a horizontal plane in order that each set of its tools while in operation on a skin resting on the table, may be so, or very nearly so, moved, I support the upper end of the rod P by means of a bell-crank, A, (see figs. 3 and 4,) pivoted to and within these stationary brackets or hangers B B' B².

The shaft of this crank has projected from it a toothed sector, D, which engages with another such sector, E. This latter is pivoted to the longer brackets B' B², and connected to a bar, F, from whose lower extremity or part a pin or stud, b, extends into a slot, m, made within the rod P, the whole being as represented in the drawings.

The two toothed sectors have equal radii.

The tool-carriage, shown at N, (provided with a

rocker-plate and tool-carriers and springs thereto as in other machines for like purposes,) has a connecting-rod bolted to and extended from its rocker-plate, such rod being pivoted to a crank-pin, n, extended from one of the arms of a fly-wheel, V.

When the fly-wheel is put in revolution, a reciprocating movement will be imparted to the tool-carriage, which, by means of the pendulous bar P and its appurtenances, as hereinbefore described, will be moved in a horizontal plane, the tendency of the bar P to swing in a circular path being counteracted by the conjoint operations of the toothed sectors, the crank and the bar F.

The supporter of the table H is represented as a series of arms, T T T, projected from a common hub or central connection, from which there extends downward a spindle or pivot, S. This spindle enters and is arranged within a tubular column or pillar R. The spindle, guided so as to be capable of moving vertically within the column, rests at its foot on the shorter arm of a balance-lever, X. Each of the arms T may be of metal, and be grooved or channeled lengthwise to receive a wooden bar, U.

From the said arms T oblique braces T' extend to an annulus or collar, W, encompassing the post R and applied to it, so as to be capable of being slid vertically thereon. The collar should not revolve on the post.

The lever X, provided with one or more weights applied to it near its outer end, serves with the said weights to nearly balance the table and its supporter, the said table being sustained on a series of inverted casters, projected upward from the arms T of the supporter. By pressing the lever X downward, the supporter may be forced upward, so as to elevate the table, and thus when there is a skin upon it, move the latter up to the tools.

A spring hook, r, attached to the end of the lever X, serves, when hooked into a ring or staple, s, fixed in the floor on which the machine may be supported, to maintain the lever in a depressed position, and thereby keep the table up to a working position relatively to the tools.

The table instead of being solid or made in the usual manner, may be constructed of small joists or timbers t t t, arranged parallel to each other, and with spaces u u u between them, these timbers being set up edgewise and rebated at their corners to receive boards v v v, the whole being as represented in fig. 8. The series of timbers and boards, after being glued together and provided with edge or boundary pieces of wood w, may be held together by tie-rods x, going through them transversely, and being provided with screws and nuts at their ends.

The object of so constructing the table is to render it light and strong, and not liable to warp. It also

enables the table to be made without knots in the wood, which, when in it, are liable to do injury to the skins while being worked thereon.

I claim—

The combination of the crank A, the two toothed sectors D E, and the bar F, with the pendulous bar P, applied to or to be used with the tool-carriage, as described.

Also, the combination of the balance lever X with

the post R, the spindle S, and the table-supporter.

Also, the table as made of the series of rebated joists or timbers and their intermediate and edge boards and holding-rods or bolts, arranged as specified.

EDWARD FITZHENRY.

Witnesses:

J. U. ZUST,

J. A. MCKEAN.