

(19) **DANMARK**

(10) **DK/EP 2949585 T3**



(12) **Oversættelse af
europæisk patentskrift**

Patent- og
Varemærkestyrelsen

-
- (51) Int.Cl.: **B 65 B 55/04 (2006.01)** **B 65 B 3/02 (2006.01)** **B 65 B 55/10 (2006.01)**
B 67 C 7/00 (2006.01)
- (45) Oversættelsen bekendtgjort den: **2017-02-27**
- (80) Dato for Den Europæiske Patentmyndigheds bekendtgørelse om meddelelse af patentet: **2016-12-07**
- (86) Europæisk ansøgning nr.: **15169823.0**
- (86) Europæisk indleveringsdag: **2015-05-29**
- (87) Den europæiske ansøgnings publiceringsdag: **2015-12-02**
- (30) Prioritet: **2014-05-30 DE 102014210306** **2014-06-10 DE 102014211059**
- (84) Designerede stater: **AL AT BE BG CH CY CZ DE DK EE ES FI FR GB GR HR HU IE IS IT LI LT LU LV MC MK MT NL NO PL PT RO RS SE SI SK SM TR**
- (73) Patenthaver: **Induflex Robert Morgan e.K., Alte Dorfstrasse 39 B, 27337 Blender, Tyskland**
- (72) Opfinder: **MORGAN, Robert, Alte Dorfstraße 39, 27337 Blender, Tyskland**
- (74) Fuldmægtig i Danmark: **Zacco Denmark A/S, Arne Jacobsens Allé 15, 2300 København S, Danmark**
- (54) Benævnelse: **Fremgangsmåde og indretning til fyldning af flasker**
- (56) Fremdragne publikationer:
EP-A1- 2 394 950
EP-B1- 2 185 466
DE-A1- 19 547 425

The present invention relates to a method and a device for filling bottles, in particular PET bottles, and also to a use of a rod, in particular a stretching rod, for inflating and filling bottles.

5

In accordance with the prior art, bottle blanks, which are also referred to as preforms, are delivered into a bottling plant and are inflated there to form the finished bottle form. This inflation is also referred to as blowing out. After the inflation or blowing out, the bottles are cleaned, sterilised and/or disinfected, and filled. It is advantageous to inflate
10 the bottles at the bottling location because it is possible to reduce transportation costs and storage area thereby.

DE 195 47 425 A1 discloses for example a bottle blank which is inflated to form a bottle.

15

Alternatively, bottling companies which have the inflated bottles delivered directly to them are also known. The reason for this is that such companies, after switching from glass bottles to the PET bottles which are more usual nowadays, e.g. in their factory facilities - in which originally glass bottles were filled - have no capacity available for
20 blowing or inflation machines for inflating the blanks. Therefore it has hitherto not been possible to inflate the blanks to form bottles within the original factory facilities of such factories - at least not without extending the factory facilities.

What is the same with all bottling companies is that the inflated bottle blank, i.e. the
25 finished bottle before bottling, has to be cleaned, sterilised and/or disinfected so that the liquid which is poured into a bottle will keep e.g. for a certain time once the bottle is closed.

For cleaning purposes, in particular disinfecting, sterilisation and/or removing germs,
30 frequently H_2O_2 is poured into the bottle or blown into the bottle.

It is therefore an object of the present invention to reduce costs in the filling of bottles and in particular to minimise the amount of media used during sterilisation, it simultaneously being necessary to maintain the quality of the cleaning.

- 5 This object is achieved with a method for filling bottles, in particular PET bottles, according to Claim 1, and also with a device for filling bottles according to Claim 5, and by the use of a rod, in particular a stretching rod, according to Claim 10.

Advantageous developments are described in the dependent claims.

- 10 The method according to the invention for filling bottles, in particular PET bottles, first of all comprises a step in which on the bottle blank, also referred to as a preform, a filling cap is arranged on a bottle blank, in particular by screwing the filling cap with a thread on the head of the bottle blank. Further, a filling head is arranged on the filling cap. Access to the interior of the bottle blank is accordingly only possible through the
- 15 filling head and the filling cap. An example of such a filling head and also the arrangement thereof on the thread is disclosed e.g. in European Patent EP 2 185 466 B1.

Further, the bottle blank is cleaned, in particular is disinfected, is sterilised and/or undergoes germ removal, through the filling cap and the filling head.

20

- Once the bottle blank has been cleaned, disinfected and/or sterilised, the bottle blank is positioned in a blow mould and inflated with compressed air to form a bottle. The inflation takes place according to a further example of embodiment with a rod, which is also referred to as a "stretching rod". The inflation is also frequently referred to as
- 25 "blowing out". At any rate, the inflation likewise takes place through the filling head and the filling cap.

- The result is a bottle, in particular a PET bottle, which has a final form as is known from the trade. The bottle, once inflated, is filled directly with the desired product to be
- 30 bottled, e.g. mineral water, spritzer, juice, milk, carbonated drinks (e.g. cola) or the like, and also medicaments, in particular in liquid form. The filling takes place via the filling head and the filling cap. After filling, the bottle is sealed, in particular by welding the filling cap in the region of the first end, and the filling head is removed.

Compared with conventional methods, thus merely the bottle blank - and not the entire bottle - has to be cleaned, i.e. in particular be disinfected, be sterilised and/or undergo germ removal. The bottle blank has a substantially smaller volume compared with the finished shaped PET bottle, and therefore a substantially smaller amount of media needs
5 to be used for the cleaning. Therefore the cleaning and thus the bottling overall can be carried out substantially more cheaply. This cleaning of the bottle blank instead of the bottle is however only made possible in that only the filling head and the filling cap permit access to the interior of the bottle blank even before inflation of the bottle blank
10 and thus contamination of the bottle between inflation and filling is no longer possible. Further, antiseptic bottling is possible.

Accordingly, the interior of the bottle or the volume of the bottle during cleaning, in particular disinfecting and/or sterilising, and also during inflation and filling, can remain
15 closed off from the surroundings. That is to say that the volume is blocked off from the surroundings before the bottle blank is cleaned, and does not have to be opened until after the bottle has been filled and sealed. This is possible since the inflation of the bottle blank and also the filling of the bottle take place in the same device.

20 According to a first embodiment, the inflation and/or the filling take(s) place with a rod, in particular a stretching rod. According to a further embodiment, at least part of the rod is introduced into the volume or the interior of the bottle blank already before the cleaning, disinfecting and/or sterilisation. This yields the advantage that this already-introduced part of the stretching rod is directly jointly cleaned, disinfected and/or
25 sterilised during the cleaning, disinfection or sterilisation step. According to a further embodiment, it is also conceivable for the cleaning medium to be introduced directly into the volume or the interior of the bottle blank by means of the rod with which the bottle which is cleaned in each case will also later be inflated and filled.

30 According to a further embodiment of the method, the bottle is sealed immediately once the rod has been removed. The bottle, which is thus substantially sterile, is thereby kept substantially sterile with respect to the surroundings.

In accordance with the device according to the invention for filling bottles, in particular PET bottles, this comprises at least one blow mould which is designed at least for inflating bottle blanks. Further, the device is set up to arrange a filling cap, and on the filling cap a filling head, on the bottle blank prior to inflation, and to clean the bottle
5 blank through the filling head and the filling cap.

Accordingly, the filling (with the product to be bottled, e.g. mineral water, spritzer, fruit juice, milk, carbonated drinks (e.g. cola) etc. and also medicaments, in particular in liquid form) and the inflation take place in one and the same machine, so that transport
10 from an inflation machine to a bottling machine is dispensed with. Thus the cleaning, in particular the disinfection and/or sterilisation, of only the bottle blank instead of the finished bottle can take place, so that cleaning of the bottle itself becomes unnecessary. Further, only a single device is necessary for filling and inflation, so that inflation can also take place in bottling companies whose production facilities hitherto had been
15 unable to provide any capacity for a separate inflation machine in addition to the bottling machine. The originally installed bottling machine of such companies can therefore advantageously be replaced simply by a bottling machine which at the same time is suitable for inflation.

20 According to one embodiment of the device, it has a conveyor, in particular a circular conveyor, for receiving and conveying bottle blanks and bottles. That is to say that only a single conveyor which receives the bottle blanks at a first point and discharges the filled bottles at another point is necessary.

25 According to a further embodiment of the device, the circular conveyor has a plurality of regions. One of the regions is a cleaning region or sterilisation region, in which the bottle blank(s) is/are sterilised or cleaned. In the subsequent blowing-out region or inflation region, the bottle blanks are inflated or blown out to form a bottle. The blown-out bottle is then filled in a subsequent filling region. Thus it is possible to fill the bottle
30 without renewed cleaning after the inflation with a single device.

According to a further embodiment, the conveyor additionally has a receiving region for receiving bottle blanks before the cleaning region. In this receiving region, further a

filling cap and a filling head on the filling cap are arranged on the bottle blank. In addition, the conveyor after the filling region has a sealing region for sealing the filled bottles and a discharge region for discharging the filled, closed bottles. Accordingly, the bottle-filling machine is suitable to receive bottle blanks - in particular preheated for
5 inflation - directly, to provide them with a filling cap and a filling head, and to clean, inflate, fill and seal them. In the discharge region, the filled bottles are then discharged directly for storage or for transporting to the point of sale.

According to a further embodiment of the device, the rod has at least a first duct with
10 first openings and at least a second duct with second openings. Accordingly, a first duct with its openings is suitable for guiding for example compressed air for blowing out or inflating the bottle blank from the outer region into the interior of the bottle blank. It goes without saying that this compressed air is sterile or substantially sterile, so that the previously cleaned bottle blank is not contaminated again. In the second duct with the
15 second openings then for example a liquid or the medium which is to be poured into the bottle can be poured into the interior of the bottle. Accordingly, controlled dispensing of the blowing-out medium and the medium for filling is possible through separate ducts with openings, without these media mixing as the result of residues.

20 Further, the invention covers the use of a rod, in particular a stretching rod, for inflating a bottle blank, in particular a PET bottle blank, to form a bottle, in particular a PET bottle, and for filling the bottle. Further, the use of the same rod for inflating and for filling the bottle makes it possible to keep the bottle closed during the inflation and the filling subsequently to the cleaning, so that renewed sterilisation after blowing out and
25 before bottling is unnecessary.

Further advantageous examples of embodiment of the invention will be explained in greater detail below with reference to the drawings.

30 Fig. 1 shows a schematic representation of a bottle blank with a rod according to a first example of embodiment of the device,

Fig. 2 a schematic representation of the inflated or blown-out bottle blank to form a bottle,

Fig. 3 an example of embodiment of the device according to the invention with further
5 components for filling.

Fig. 4 an example of embodiment of a bottle with a filling head and filling cap arranged thereon,

10 Fig. 5 an example of embodiment of a cleaning step,

Fig. 6 an example of embodiment of a filling step,

Fig. 7 an example of embodiment of a sealing step, and
15

Fig. 8 the removal of a projecting part of the filling cap.

Fig. 1 shows a schematic representation of a bottle blank 10, also referred to as a preform. The bottle blank 10 is introduced into an inflation mould 11. In the upper
20 region, i.e. on the bottle head, the bottle blank has a circumambient thread 12 and also a circumambient collar 14. The bottle blank 10 is a bottle blank 10 for a PET bottle. In the region of the thread 12, the bottle blank 10 has an opening 15.

Through the opening 15, a rod 16, here a stretching rod, is introduced into the bottle
25 blank 10. The stretching rod has a first duct 17 and a second duct 18. The first duct 17 communicates with first openings 19 and the second duct 18 communicates with a second opening 20.

Further, a bottling cap 21 and a bottling head 22 or filling head 22 is illustrated. The
30 bottling cap 21, according to this example of embodiment, is arranged with its first end on the bottling head 22 and with its second end on the bottle blank 10, e.g. by screwing on the thread 12. Thus the interior 25 of the bottle blank 10 is closed off from the

surroundings, in particular in substantially airtight manner, and is only accessible via the bottling cap 21 and/or the stretching rod 16 or the openings and ducts thereof.

Fig. 2 shows, by comparison with Fig. 1, the bottle blank 10 which is now inflated to form the bottle 23. The form of the bottle 23 is adapted to the inflation mould 11. The bottle blank 10 has been inflated with compressed air via the first ducts 17 and the openings 19. The rod 16 continues to be located in the interior of the bottle 23. The bottling cap 21 after blowing out and prior to filling has not been removed from the opening 15 above the thread 12. Through the opening 20, via the second duct 18, a liquid 24 is poured into the bottle 23 through the rod 16.

Further, two welding heads 26 of a welding device, in particular an ultrasonic welding device, are illustrated schematically. The welding heads 26 are arranged to be movable in the direction of the arrow 27, and for sealing the filling cap 21, in particular for welding the filling cap 21, are pressed against the region of the first end of the filling cap 21, so that the outer walls of the filling cap 21 are pressed together until they touch, in order then to be in particular welded. Once the bottle 23 has thus been sealed, the filling head 22 is removed, whereas the filling cap 22 remains on the bottle 23 as a closure.

20

Fig. 3 shows a schematic sequence of an example of embodiment of the method with its steps using a schematic representation of an example of embodiment of the device.

First of all, a container 30, in which the bottle blanks 10 are stored and which is also referred to as a preform bunker, is shown. From the container 30, the bottle blanks 10 undergo the method or pass through the device and further components until a filled bottle 23 is discharged at the end 32. First of all, the bottle blanks 10, after leaving the container 30, are oriented in a roller sorter 34, in particular with their openings 15 upwards. The bottle blanks 10 are supplied to a heating tunnel 38 via a first deflecting section 36. In the heating tunnel 38, the bottle blanks are preheated in preparation for later blowing-out or inflation.

30

The preheated bottle blanks 10 are supplied to an example of embodiment of the device 41 according to the invention via a second deflecting section. The device 41 comprises a conveyor 42, here a circular conveyor, with a receiving region 43 for receiving the bottle blanks 10 and for arranging a filling cap 21 and a filling head 22 on the bottle blank, a cleaning or sterilisation region 44 for cleaning and/or sterilising the bottle blanks 10, an inflation region 46 for inflating the bottle blanks 10 to form a bottle 23, a filling region 48 for filling the bottle 23 and a sealing region 50 for sealing the filled bottle 23.

10 In a subsequent discharge region 52, the filled bottles are then transferred to a third deflecting section 53 in order to guide the filled bottles for example into a store, not shown.

The device 41 permits the inflation or blowing out of the bottle blanks 10 and also the filling of the bottles 23, and is thus space-saving. According to this example of
15 embodiment, likewise cleaning of the bottle blanks 10 instead of the bottles is possible with the device, the bottle blanks 10 having a smaller volume than the bottle 23 and thereby a saving in terms of the cleaning medium, in particular ozone, being made.

20 Further, Fig. 4 shows the bottle blank 10 with bottling cap 21 arranged thereon and the bottling head 22 arranged on the bottling cap 21. In Fig. 5, ozone 54 is then blown into the interior of the bottle. The inflation step is not shown. In Fig. 6, the inflated bottle 23 is filled with a liquid 24, and in Fig. 7 the filled bottle 23 is sealed with two ultrasonic welding heads 26. For this, the bottling cap 21 is compressed and welded in the middle
25 region. Fig. 8 shows the cutting-off of a part 55, which is no longer needed, of the bottling cap 21 with a severing means 56.

Patentkrav

1. Fremgangsmåde til fyldning af flasker (23), især PET-flasker, omfattende trinnene:
- 5 - at placere et påfyldningslåg (21) på et flaskeemne (10) og anbringe et påfyldningshoved (22) på påfyldningslåget (21),
 - at rengøre, især desinficere, sterilisere og/eller fjerne bakterier fra, flaskeemnet (10), især en preform, gennem påfyldningslåget (21) og påfyldningshovedet (22),
 - 10 - at puste flaskeemnet (10) op til en flaske (23) gennem påfyldningslåget (21) og påfyldningshovedet (22),
 - at fylde flasken (23) gennem påfyldningslåget (21) og påfyldningshovedet (22), især med en stang (16), f.eks. en reckstang,
 - at lukke påfyldningslåget (21) og fjerne påfyldningshovedet (22).
- 15 2. Fremgangsmåde ifølge krav 1, hvor oppustning af flaskeemnet (10) til en flaske (23) og fyldning af flasken med den samme stang (16), især en reckstang, sker, og/eller oppustning af flaskeemnet (10) til en flaske (23) og fyldning af flasken i hvert tilfælde sker i den samme blæseform (11).
- 20 3. Fremgangsmåde ifølge krav 2, hvor mindst en del af stangen (16) allerede indføres i flaskeemnet (10) med henblik på rengøring af flaskeemnet (10).
4. Fremgangsmåde ifølge et af de foregående krav, hvor flasken (23) lukkes umiddelbart efter fjernelse af stangen (16).
- 25 5. Indretning til fyldning af flasker (23), især PET-flasker, omfattende mindst en blæseform (11) til oppustning af flaskeemner (10), især preforme, gennem et påfyldningslåg (21) og et påfyldningshoved (22),
- kendetegnet ved, at**
- 30 indretningen er indrettet til at anbringe påfyldningslåget (21) på flaskeemnet (10) før oppustning og anbringe påfyldningshovedet (22) på påfyldningslåget og rengøre flaskeemnet (10) gennem påfyldningshovedet (22) og påfyldningslåget (21).

- 6.** Indretning ifølge krav 5, hvor indretningen omfatter en transportør (42), især en cirkulær transportør, til optagelse og transport af flaskeemner (10) og flasker (23).
- 5 **7.** Indretning ifølge krav 5 eller 6, hvor indretningen, især transportøren (42), omfatter følgende områder:
- et optagelsesområde (42) til optagelse af flaskeemnerne (10) og til anbringelse af påfyldningslåget (21) og påfyldningshovedet (22),
 - 10 - et rengøringsområde (44) til rengøring, især til desinficering af, sterilisering af og/eller fjernelse af bakterier fra, flaskeemnerne (10),
 - 15 - et oppustningsområde (46) til oppustning af flaskeemnerne (10) til en flaske (23) og
 - et fyldningsområde (48) til fyldning af flasken (23),
 - et lukkeområde (50) til lukning af de fyldte flasker (23) ved svejsning af påfyldningslåget (21).
- 8.** Indretning ifølge krav 6 eller 7, hvor transportøren (42) omfatter et afgivelsesområde (52) til afgivelse af de fyldte lukkede flasker (23).
- 20 **9.** Indretning ifølge et af kravene 5 til 8, hvor stangen (16) omfatter mindst en første kanal (17) med mindst en første åbning (19) og mindst en anden kanal (18) med mindst en anden åbning (20).
- 25

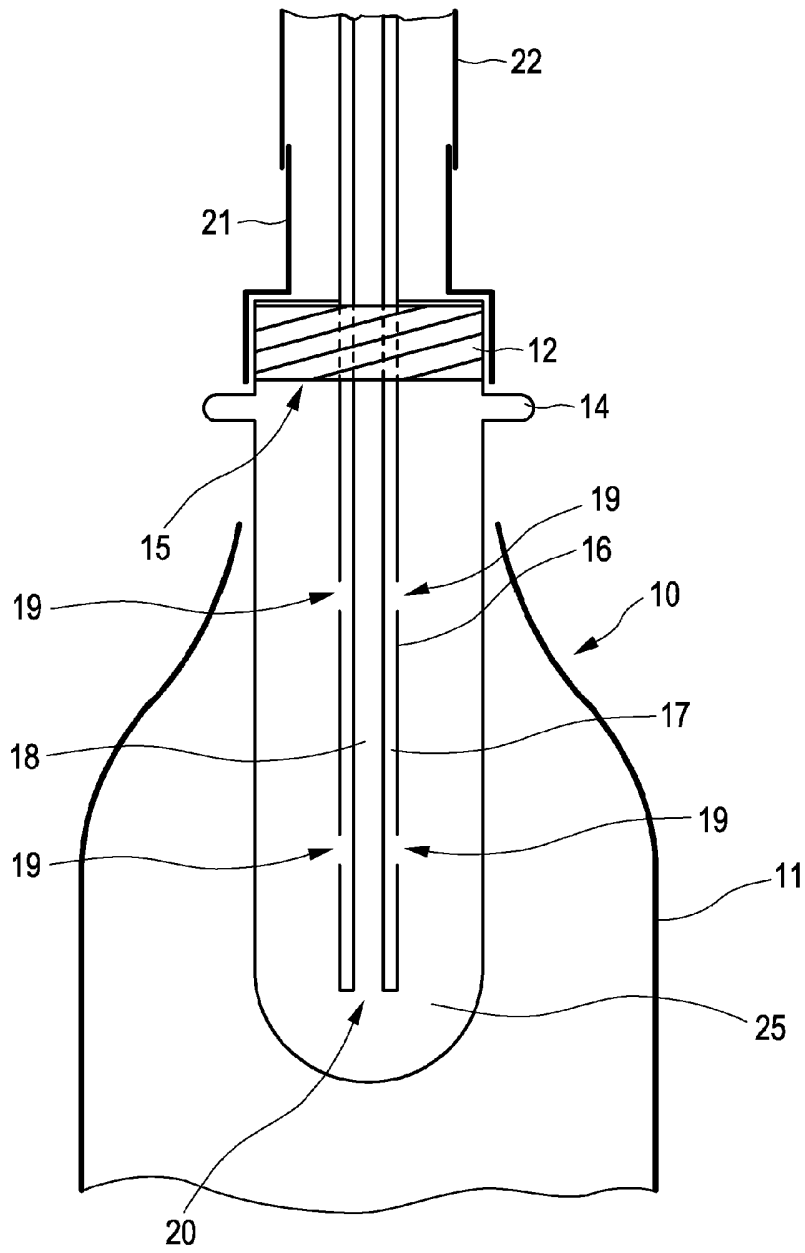

Fig. 1

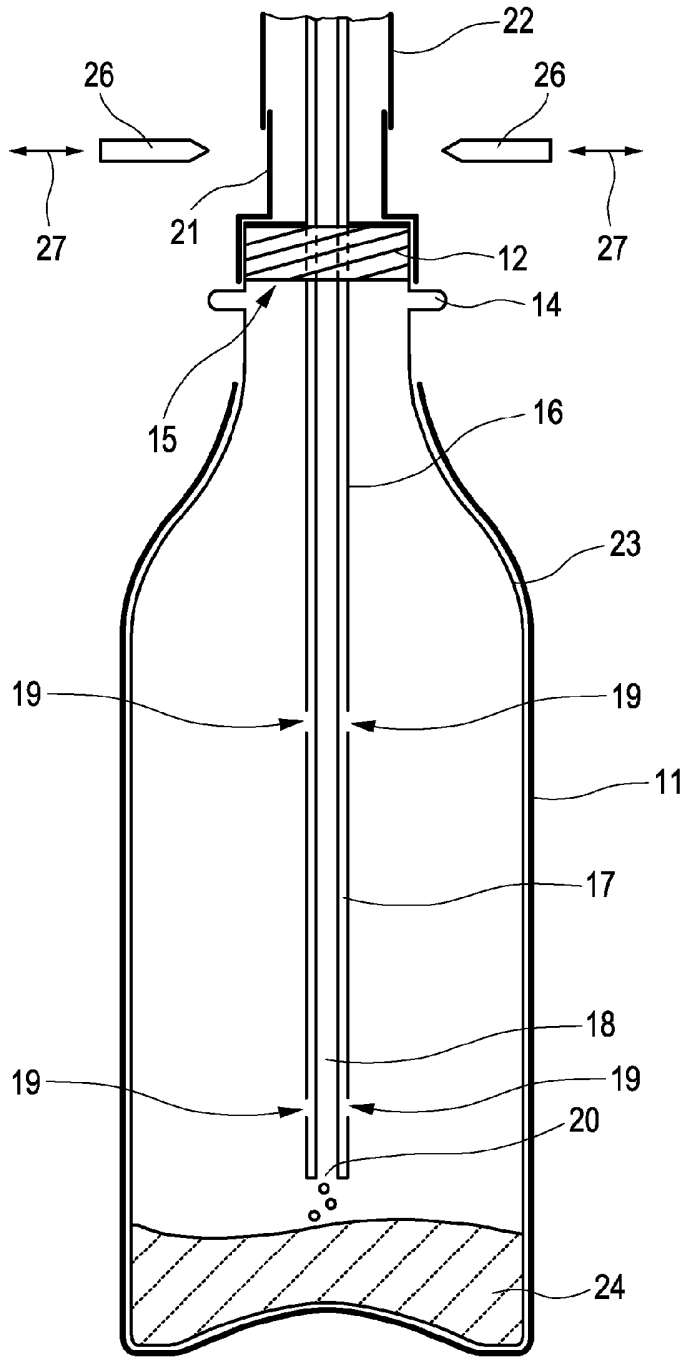

Fig. 2

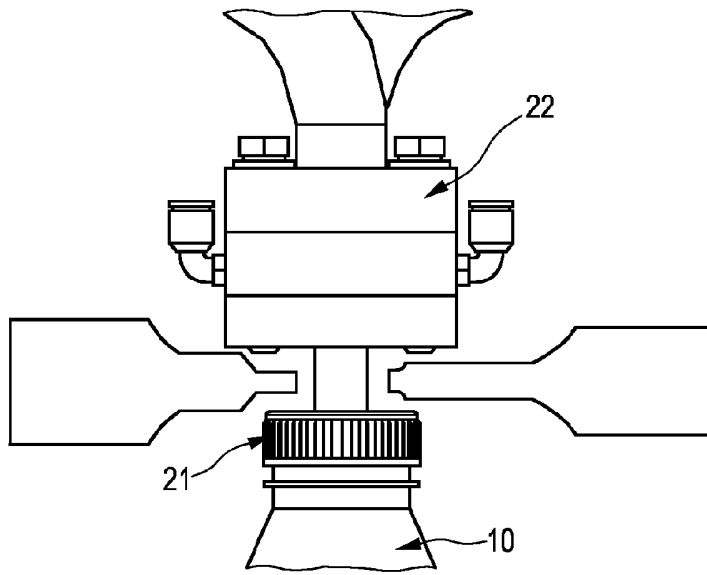

Fig. 4

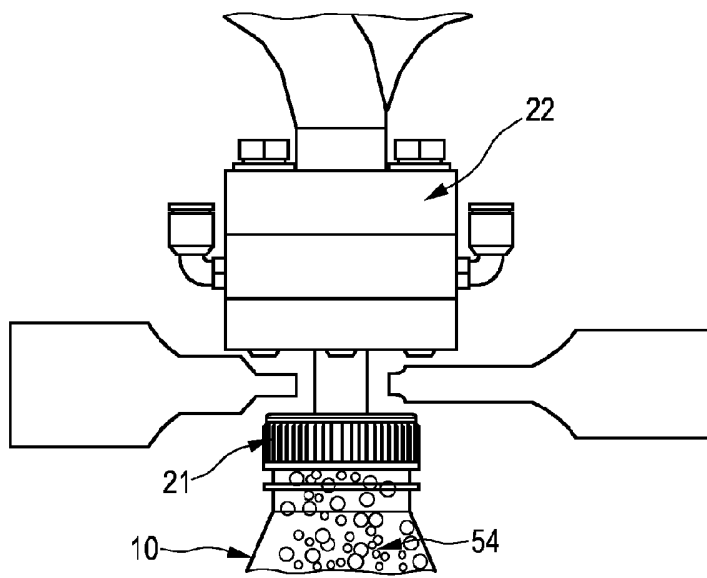
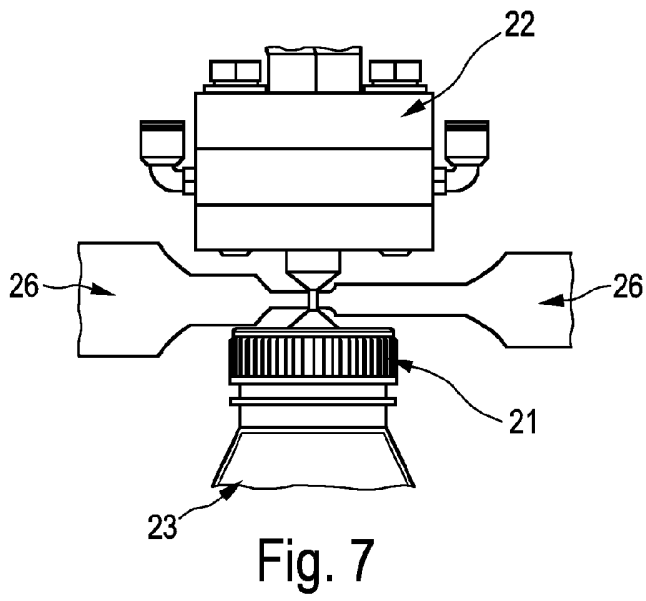
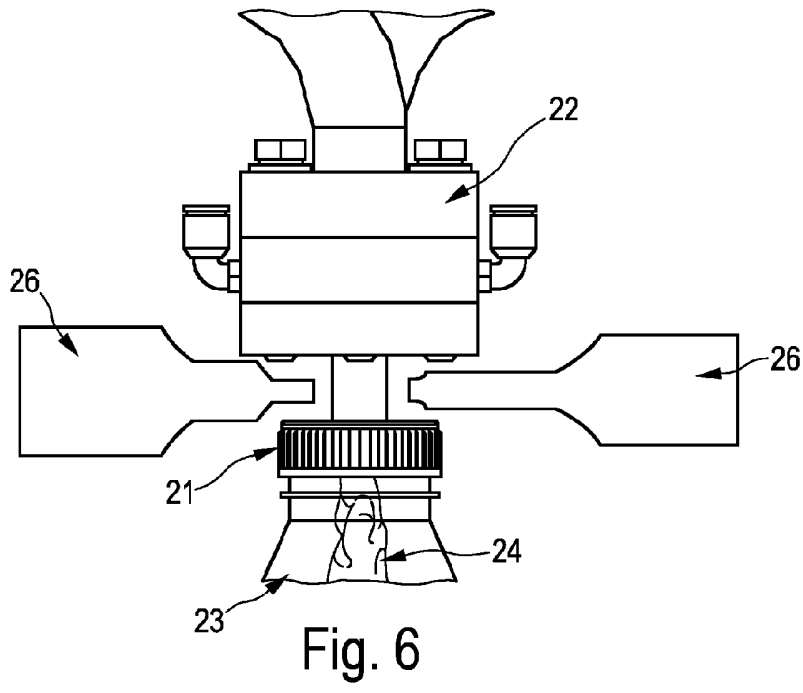

Fig. 5



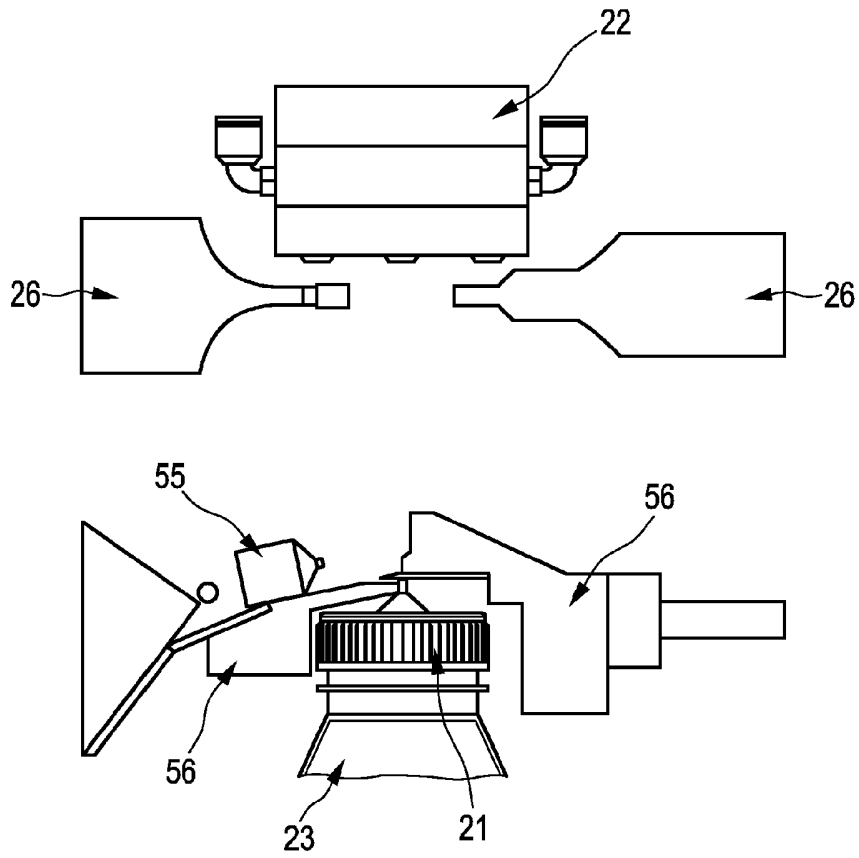

Fig. 8