

A. R. BULLOCK.
ELECTRICALLY OPERATING PRINTING DEVICE.
APPLICATION FILED APR. 24, 1913.

1,275,657.

Patented Aug. 13, 1918.

4 SHEETS—SHEET 1.

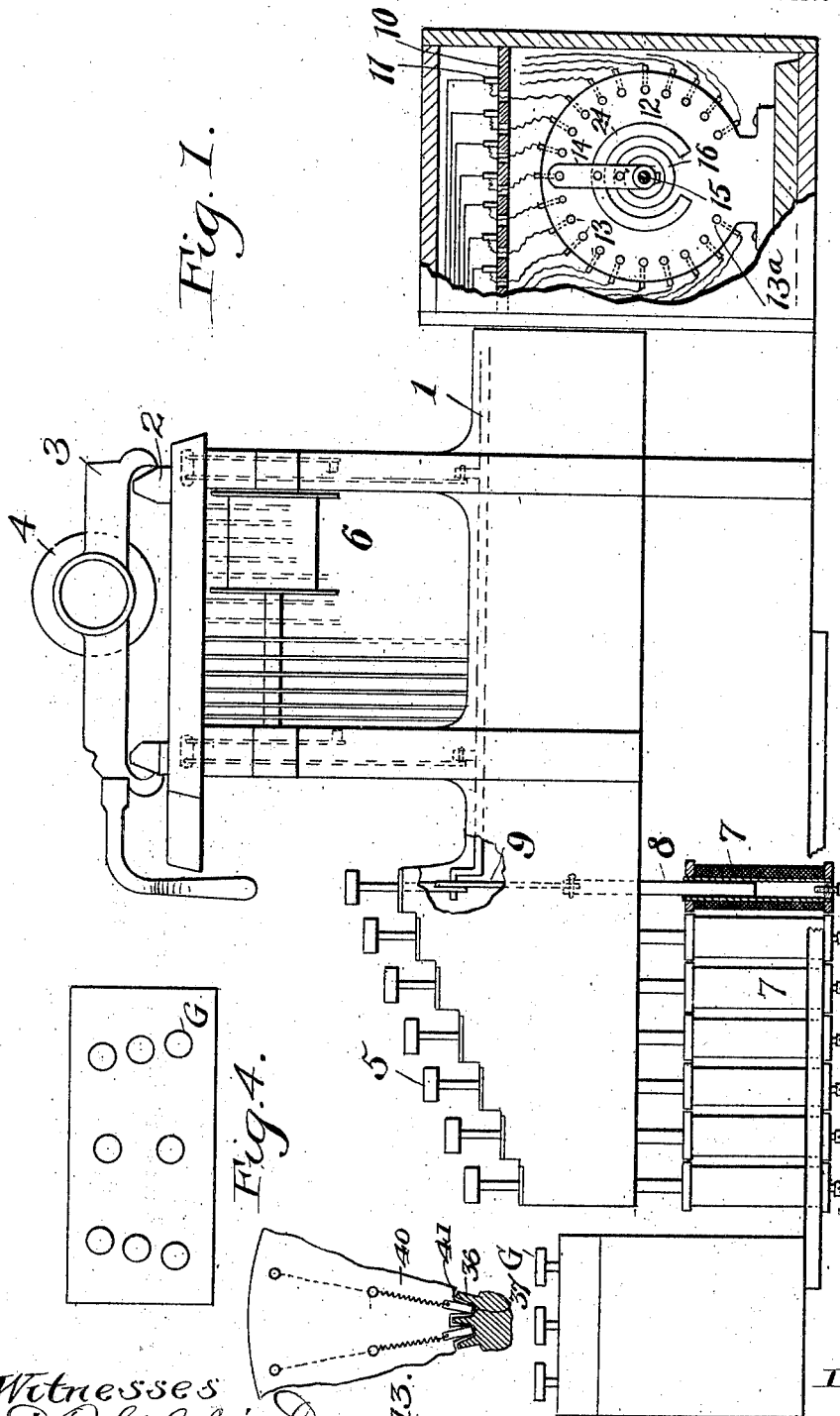

Fig. 1.

Fig. 4.

Fig. 13.

Witnesses
E. B. Gilphie
A. J. Hudson

Inventor
Arthur R. Bullock
by Thurston & King
attys

1,275,657.

Patented Aug. 13, 1918.
 4 SHEETS—SHEET 2.

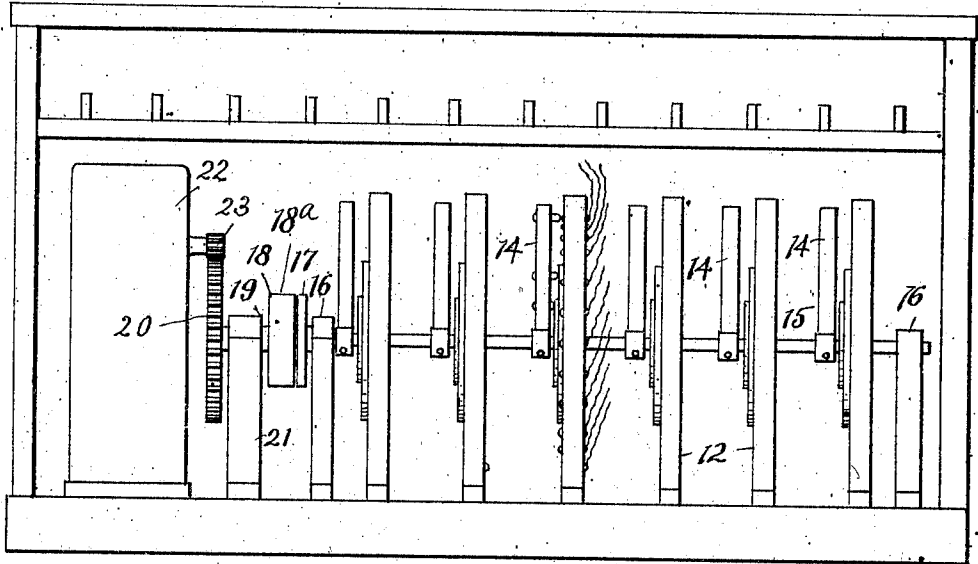

Fig. 2.

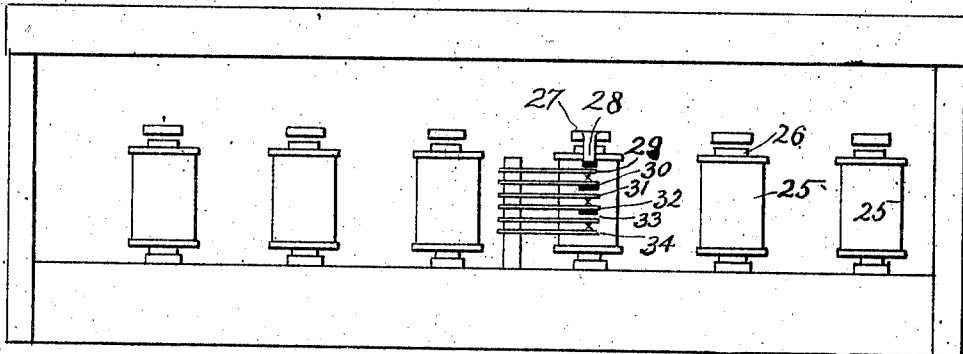

Fig. 3.

Witnesses
 E. B. Gilchrist
 A. J. Hudson

Inventor
 Arthur R. Bullock
 by Thurston & Kinn
 atty

A. R. BULLOCK.
ELECTRICALLY OPERATING PRINTING DEVICE.
APPLICATION FILED APR. 24, 1913.

1,275,657.

Patented Aug. 13, 1918.

4 SHEETS—SHEET 3.

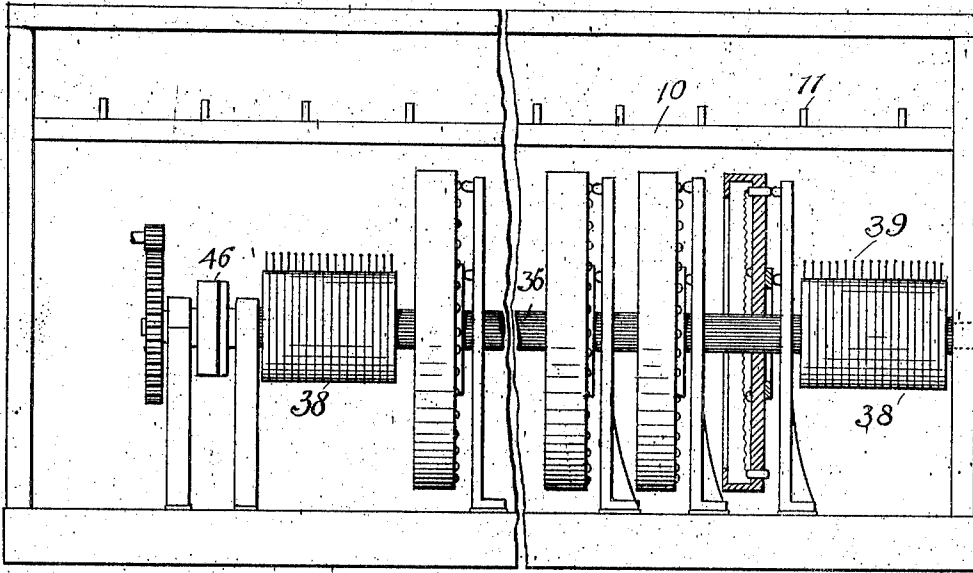

Fig. 5

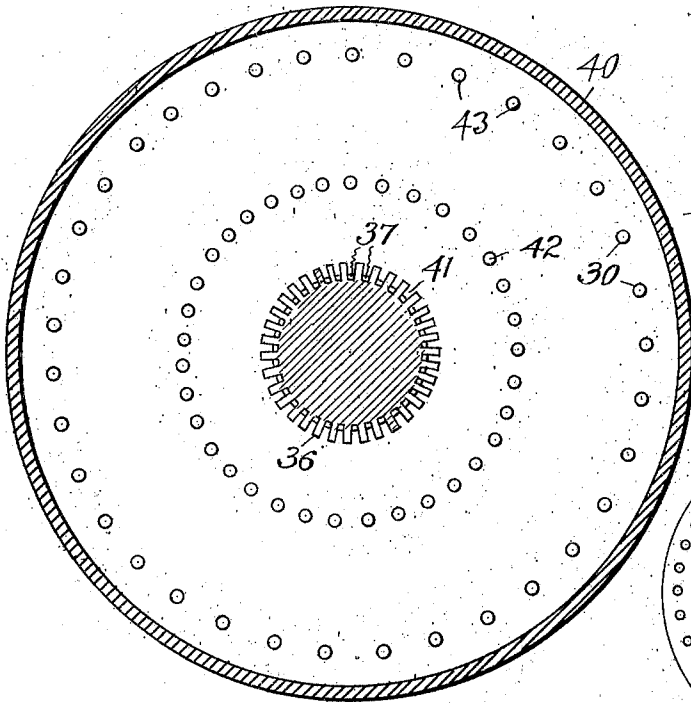

Fig. 7.

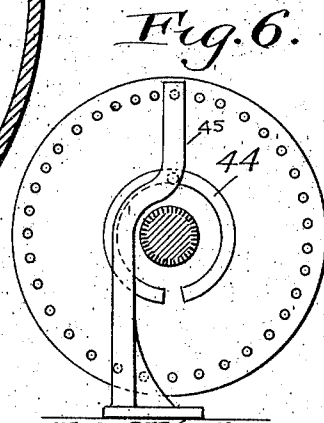

Fig. 6.

Witnesses
E. B. Gilchrist
A. J. Hudson

Inventor
Arthur R. Bullock
by Thurston & Kniss
attys.

A. R. BULLOCK.
ELECTRICALLY OPERATING PRINTING DEVICE.
APPLICATION FILED APR. 24, 1913.

1,275,657.

Patented Aug. 13, 1918.

4 SHEETS—SHEET 4.

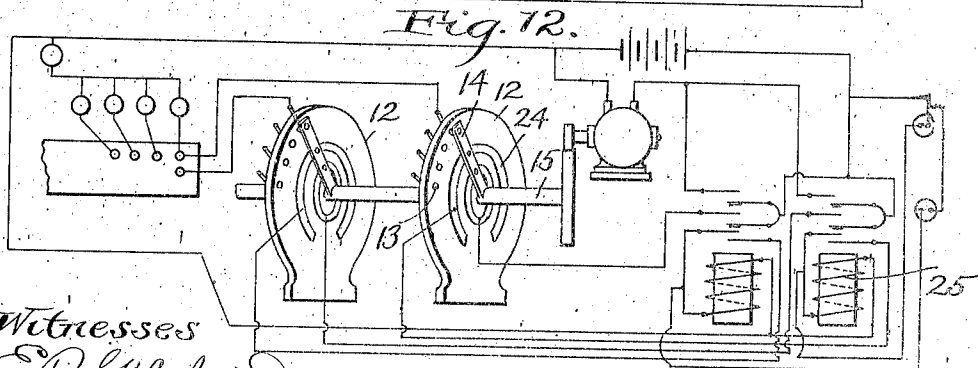
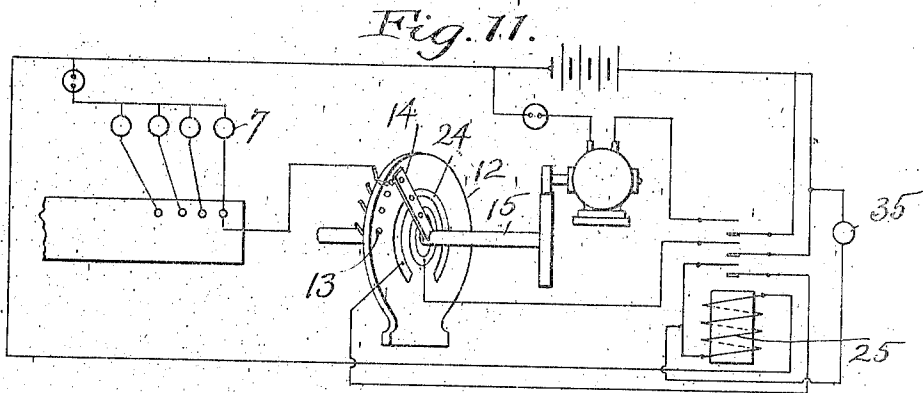
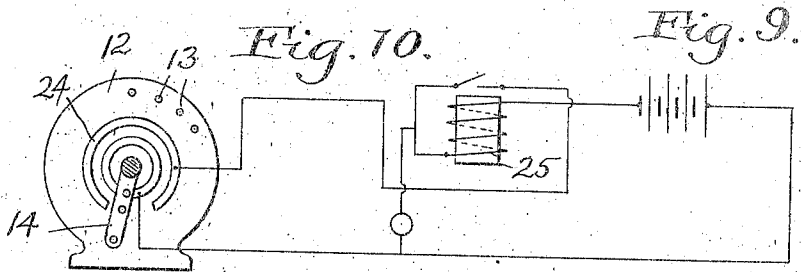
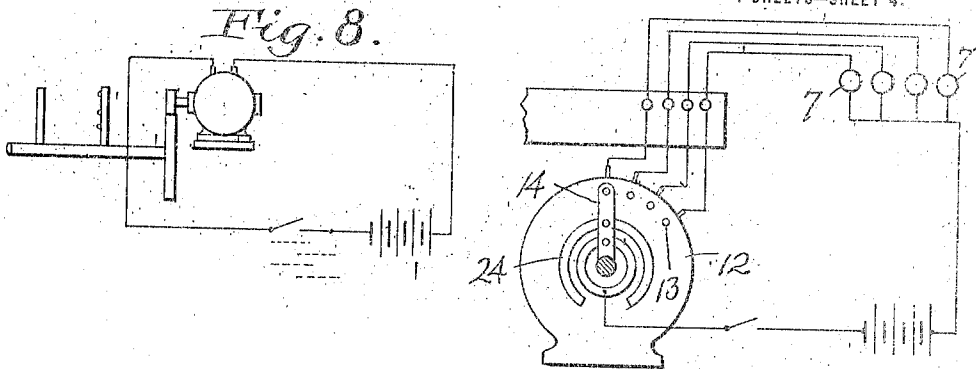

Witnesses
E. B. Gilchrist
A. J. Hudson

Inventor
Arthur R. Bullock
by Thurston W. Foster
attor

UNITED STATES PATENT OFFICE.

ARTHUR R. BULLOCK, OF CLEVELAND, OHIO.

ELECTRICALLY-OPERATING PRINTING DEVICE.

1,275,657.

Specification of Letters Patent. Patented Aug. 13, 1918.

Application filed April 24, 1913. Serial No. 763,200.

To all whom it may concern:

Be it known that I, ARTHUR R. BULLOCK, a citizen of the United States, residing at Cleveland, in the county of Cuyahoga and State of Ohio, have invented a certain new and useful Improvement in Electrically-Operating Printing Devices, of which the following is a full, clear, and exact description.

This invention relates to a mechanism for automatically causing the selection of printing elements according to a predetermined relationship.

The invention herein disclosed is applicable to linotype machines, typesetting machines or similar machines, as well as to printing machines such as typewriters and similar machines.

For purposes of disclosure, I will describe my invention as applied to a typewriting machine, but this forms no limitation upon its other uses.

Generally speaking, this invention, as applied to typewriters, has for its object to provide a typewriter, which will automatically write predetermined legends, such as words, phrases or sentences, all of which will be effected by making a proper connection to put in operation the mechanism for operating the type bars to produce the desired legend.

As is well known in every business, there are certain features which may be termed "stock phrases". For instance, such phrases as "Dear Sir", "Gentlemen", "Yours truly", and many others are practically all stereotype in form. There are also many business letters which are practically uniform, except that there might be slight changes relating to dates, prices or similar matter.

But it is, however, considered bad business form to send out these letters as a printed form. Good custom and business etiquette demand that a typewritten letter be sent, and therefore there is in many businesses a needless waste of time and energy in preparing such letters by ordinary manual methods.

By this invention the loss of time and energy incident to such letters as well as expense may be largely eliminated, for the typewriting can be made largely automatic in the writing of the various stereotype parts of the letter, stopping at such time as necessary for the operator to insert the special

item or matter and finally producing a finished letter largely, or perhaps wholly automatically written, yet presenting all the features of a manually typewritten letter.

Another feature of a machine of this character lies in the fact that the stenographer or operator is saved a large amount of needless labor, thereby making it possible for the operator to do more work in a given time, and to do it more efficiently.

I am aware that it has been proposed to place the type letters of a word or phrase of limited extent upon a single type bar, so that an operation of the single bar will cause the words or phrases to be printed by the one operation of the type bar. My device differs from such constructions in that the individual type bars carrying the letters composing the legend are operated successively and in proper sequence.

As will readily be seen this automatic writing may not only be a word or phrase, but a sentence or a succession of sentences multiplied to any extent.

One particular advantage of producing such automatic typewriting by the instrumentality of a typewriter lies in the fact that all the peculiarities of the particular machine appear throughout the automatically written part, so that there will be no typographical differences between the automatically written part and the hand written part.

Furthermore, the machine of this invention makes it possible to cause the type to make impressions of varying strength, thereby more clearly simulating the manually written part, for it is very well known that in manually written letters all the impressions of the letters are not of equal strength, due to the fact that the operator does not press all the keys with equal pressure.

Generally speaking, the invention may be said to comprise the elements and combinations thereof set forth in the accompanying claims forming a part of this specification.

Reference should be had to the accompanying drawings, in which Figure 1 is a side elevation with portions in section of a form of typewriter embodying my invention. Fig. 2 is a rear elevation of a portion of the mechanism of my invention. Fig. 3 is an elevation of certain relays employed.

Fig. 4 is a top plan view of the keys or switch button to make the inaugural electrical connection. Fig. 5 is a rear elevation similar to that shown in Fig. 2, but of a modified construction. Fig. 6 is a side elevation of a disk and contact bar such as shown in Fig. 5. Fig. 7 is an enlarged view of a modified form of legend disk. Fig. 8 is a diagrammatic illustration of the electrical connections between the motor and battery. Fig. 9 is a diagram of electrical connections between the battery, type-bar solenoids, the distributor board and a legend disk. Fig. 10 is a diagram of the electrical connections between the battery relay and time switch which holds the relay circuit closed. Fig. 11 is a diagram of the electrical connections between the various instrumentalities of my device, and a single battery when a single legend disk is used, Fig. 12 is a diagram similar to Fig. 11, except that two legend disks are used. Fig. 13 is an elevation with portions in section of one part of the machine.

In Fig. 1 there is illustrated a double keyboard typewriting machine, the construction of which for the purpose of this invention may be of ordinary and usual type and includes a base 1, carrying a track 2 upon which is mounted a traveling carriage 3, which in turn carries a platen 4. The keyboard is represented at 5, and is connected by suitable link elements with a nest of type-bars represented generally at 6. The mounting of the type-bars, as well as the mechanical connections between the type-bars and the keys is of usual construction.

There are a set of solenoids, one of which is represented at 7 in Fig. 1. In this particular instance, the number of solenoids corresponds to the number of characters or keys represented in the keyboard. Each solenoid is of ordinary construction and is provided with a hollow central portion, into which may slide a permeable core 8. The core of each solenoid is connected in the present instance directly with one of the keys, by means of a link such as illustrated at 9, in Fig. 1.

The particular showing of the connection between the solenoid cores, and the keyboard is but by way of illustration, and no particular claim is made to this feature. The important fact in connection with the construction is that the operation of the cores of the solenoid will effect a movement of the corresponding type-bar to which it is mechanically connected.

From the construction as just described, it will be clear that when any solenoid is electrically energized, it will cause a movement of its core into the solenoid. These cores are placed so that under ordinary conditions, they will extend only a short distance within the solenoid so that the cores will

be moved farther into the solenoids, as the various solenoids are energized. This movement of the core into the solenoids produces the movement of a corresponding type bar, which will in turn produce an impression upon the platen.

Each solenoid has one end of the winding thereof connected in parallel with a source of electrical energy, while the other end of the winding thereof is electrically connected to a distributing board, as shown at 10 in Fig. 1. This board is a platform provided with projecting posts, one of which is represented at 11, and to the proper posts there is connected the solenoid winding.

At 12, in Fig. 1, there is represented what I term a legend disk. In the particular form of the invention shown, this disk is secured upon a proper base. Upon one surface of the disk there is provided a series of contact points, represented at 13, which may be of any desired construction, and suitable electrical connections are made between the posts 11 of the distributing board and the contacts 13, to spell out the particular word, phrase or sentence which it is desired to automatically write. For instance if it be desired to write the words—"Dear Sir," the first contact 13^a will be connected to the distributing board, and to the post thereon connected to the solenoid which operates the "D" type bar, and so on through the word "Dear." To space the words, the fifth contact would be connected through the distributing board with the solenoid which operates the spacer bar. The electrical connection to effect the writing of the word "Sir" would, in kind, be just the same as that described, for the word "Dear."

If it be desired to capitalize the words "Dear" and "Sir," then the contact 13^a and the proper subsequent contacts would also be electrically connected through the distributing board with the solenoids which operate the keys carrying capital "D" and capital "S."

Of course it will be understood that in the event this invention be applied to a single keyboard machine, the contact 13^a and the sixth contact therefrom will be connected to the solenoid which operates the shift key.

Mounted upon the disk 12 is an arm 14, the same being secured upon the shaft 15 which extends through the central portion of the disk. Preferably the arm 14 is insulated from the shaft, and merely partakes of its rotary motion. At the outer part, the arm is provided with a portion which may engage with the contact 13, and near its inner portion the arm is provided with a contact which engages with a ring 16 of conducting material, which ring is mounted upon the disk. This ring is electrically connected with the source of electrical energy.

The electrical connections for the assemblage of instrumentalities which have just been described may be diagrammatically illustrated in Fig. 9, and from this it will be seen that as the shaft 15 is turned, the arm 14 will successively contact with the various contact members 13, and in so doing will complete the electrical circuits through the particular solenoids which are connected with the contacts upon the legend disk, and the solenoids will in turn operate their corresponding type bars.

It is my intention to use a separate legend disk carrying contact members to write a single line or portion thereof.

In Fig. 2 I have shown a series of disks 12 and each of these disks may be electrically connected with the solenoids to cause the automatic writing of a line or fraction thereof.

As before stated, the arms 14 are mounted upon a shaft 15, and this shaft is at its end journaled in standards 16. At one end of the shaft, there is rigidly mounted a plate 17, of permeable material, which is mounted opposite to a plate 18 also of permeable material. This plate is carried upon one end of a shaft 19 which at its opposite end carries a gear wheel 20. The shaft itself is mounted in a standard 21.

At 22 there is represented a motor, which upon its shaft is provided with a small gear wheel 23, meshing with the gear 20. The motor may be run continuously when the machine is in operation, so that the disk 18 is continuously operated. Suitable electrical connections may be made with a coil 18^a which is carried by the disk 18 and when this electrical coil is energized, the disks 17 and 18 will be attracted to each other and the friction between the disks will be sufficient to cause the shaft 15 to rotate.

It will be seen from the foregoing description that it is necessary to maintain the electrical circuit between the solenoids and the contacts on the legend disks, so that the circuit will be made at each contact point, and the relationship not be destroyed, as the arm 14 passes from contact point to contact point.

Of course, the circuits may be maintained, if a switch be mechanically held closed by the operator, but this would be somewhat inconvenient, and therefore, I have provided a means for electrically maintaining the circuits until the word, phrase, or sentence being printed is completed. The mechanism for accomplishing this result comprises a circular member 24, as shown in Fig. 1, which is carried by each of the disks 12. While this ring is circular in shape, it is not closed, there being a section removed.

The arm 14 carries a portion which contacts with this ring 24. The ring is electrically connected with a two-point switch,

which, during the writing of any legend, is held in contact by a relay which will presently be described.

In Fig. 3, there is shown a series of relays 25. The relays and disks correspond in number, so that each disk has its corresponding relay. These relays are of ordinary construction comprising a spool coil provided with a stationary permeable core 26, and above each core is a pivoted armature 27, which is provided with a depending arm 28. This arm is in the path of a series of point switches, the arms of which are flexible, their inherent flexibility normally holding them from contacting with each other. When, however, the relay is energized, and the armature is attracted toward the core, the arm 28 causes these switches to successively engage and thereby start the various instrumentalities for effecting the automatic operation of the typewriter.

The arms 29 and 30 form the switch terminals for the circuit which operates the magnetic clutch 17 and 18, shown in Fig. 3. The terminals 31 and 32 are connected with the return circuit from the arm 14 of each disk to the battery or source of power, while the contact members 33 and 34 are electrically connected in the circuit between the contact strip 24 and the winding which energizes the solenoid itself.

It will readily be seen that the circuit between the solenoid winding and the contact strip 24 cannot be made until the arm 14 is in such position that the contacts thereon may engage with the contact strip 24. Consequently, it is necessary to provide some means for causing an energization of the windings of the relay until the arm 14 and the contact strips 24 are in engagement. This is secured by providing a short circuiting switch which shall place the windings of the relay directly in circuit with the source of energy. This particular switch may conveniently take the form of a button switch or a switch which may simulate the keys usually employed upon typewriters. The manner in which this key or switch is electrically connected in the circuit may be noted at 35, in Fig. 11.

There will be as many of these switches or keys as there are disks and relays, and these switches may be grouped as shown in Fig. 4, either in front of the keyboard, as shown in Fig. 1, or at the side of the keyboard, or any other place that may be convenient to mount them. Each switch key will be provided with a suitable designation, which will indicate to the operator the particular legend which will be automatically written upon the pressure of the same.

It will be understood that as the button switch 35 is depressed, the circuit from the battery or source of current is closed through the coil of the relay, which causes

the attraction of the armature 27. In its descent the armature will cause the successive closure of the switches which are in its path. The first switch to be closed will preferably be the one closing the circuit between the battery and the magnetic clutch, so that the shaft 15 will immediately begin to turn. The next switch closed will complete the return circuit between the movable arm 14 and the source of current of the particular disk which is to be brought into operation, while the closure of the third switch completes the circuit between the contact switch 24 and the winding upon the relay. However, the circuit through the relay will not be maintained until the arm 14 is in contact with the contact strip 24, but as will be readily seen, the arm and the strip 24 will contact very shortly after the shaft begins to turn, and when this takes place, current will continuously flow through the coil of the relay while the arm 14 makes a revolution, during which time it is successively engaging the various contacts on the disk and causing the automatic operation of the type bars. When the shaft has made a complete revolution, the arm 14 passes from contact with the contact strip 24, thereby breaking the circuit through the winding of the relay, and releasing the armature 27, which in turn permits the various switches which have heretofore been held by the armature to open and break the circuits which have been heretofore closed by their contact. It will thus be seen that although all the arms carried by the shaft 15 will rotate, yet the circuits will be closed only through the particular disk whose relay has been energized by making electrical connections by pressing the proper starting button.

The showing in Fig. 11 diagrammatically represents the electrical connections between the source of energy the solenoids, distributing board, magnetic clutch, legend disk and relay, where a single disk is used.

Fig. 12 illustrates the electrical connection between the same instrumentalities except that two legend disks are shown, and it will be apparent that the same electrical connection will be employed in using three or more disks, as suggested in Fig. 12.

In Fig. 5 there is illustrated a modification of the device heretofore explained. In this modification, the legend disks are mounted directly upon a shaft so as to turn therewith, while the contact arms are stationarily mounted. This form of the invention permits various disks bearing different legends to be put on or removed from the shaft.

In this form of the invention, a shaft 36 is provided with a series of grooves which extend substantially throughout the length of the shaft. The shaft is of insulating material and in the bottom of each groove there

is a strip 37 of conducting material. This strip extends throughout the length of the shaft and is electrically connected with one of the rings 38. These rings 38 are of conducting material, and are insulated from each other, making contact only with one of the conducting strips 37, as heretofore explained. Upon each ring there bears a brush 39, and each brush is connected with one of the posts 11 of the distributing board.

It will be understood that there are a sufficient number of rings 38 and grooves in the shaft to correspond with the keys of the typewriter, upon which the invention is used.

Each legend disk as represented at 40, will be provided with a series of inwardly extending prongs or teeth 41, which will be of proper form and size to fit within the grooves and contact with the strips of conducting material 37. These projections 41 are of conducting material, while the body of the legend disk is preferably of non-conducting material, wherefore these various projections 41 will be suitably insulated from each other.

Each of the projections 41 is electrically connected with a corresponding binding post 42, and there are in number binding posts corresponding with the number of projections 41, or in other words, the binding posts correspond in number with the keys of the typewriter. There is also a series of binding posts upon each disk 40, as represented at 43. These contact members extend through the disk and project upon the face thereof. The inner portions of these members 43 are connected in a suitable manner with the binding posts 42, the connection being such as will automatically produce the operation of the type bars in proper sequence to print the desired word or legend. Of course care must be taken that the disks be assembled in proper relation to the shaft, that is that the projections 41 of the disks shall seat in the proper grooves in the shaft.

Each one of these disks 40 is provided with the circular contact strip 44 which is similar to the contact strip 24, which has heretofore been described.

At 45 there is represented a contact arm which is stationarily mounted adjacent each legend disk, this arm being in proper position to contact with the row of contacts 43, and also being provided with a contact which engages with a circular ring 44,—these last mentioned electrical connections being the same as those which have heretofore been described with respect to the other form of my invention.

At 46 there is shown a magnetic clutch arrangement which is of the same construction as that which has heretofore been explained, and the operation of this clutch

is such as to cause the shaft to turn, and with it the legend disks.

The operation and the electrical circuits for the operation of the modified form of device which I have just described, are the same as that described in connection with my first form of machine.

Having described my invention, I claim:

1. In a machine of the character described, the combination with a plurality of symbol carrying members of electrical means, including a movable contact member for automatically selecting and operating in proper sequence a plurality of said symbol carrying members.

2. In an automatic printing machine, a plurality of symbol carrying members, electrically actuated means for operating said symbol carrying members individually, a legend member having a series of contacts, each of said contacts being electrically connected to a separate means for operating the symbol carrying member, a contact member adapted to successively engage the aforesaid contacts, and a source of electrical energy connected in circuit with the contact member, and aforesaid electrically actuated means for operating the symbol carrying members.

3. In an automatic printing machine, a plurality of symbol carrying members, electrically actuated means for individually operating said symbol carrying members, a legend member having a series of contacts, each contact being electrically connected to a separate means for operating the symbol carrying members, a contact member adapted to successively engage the said contacts, the said contact member and legend member being relatively movable, and a source of electrical power connected in series with the contact member and in parallel with the means for individually operating the symbol carrying member.

4. In a typewriter, the combination with a plurality of type bars, and means for operating said type bars, electrically operated means for individually operating said type bars, a legend disk having a series of contacts thereon, said contacts being individually electrically connected to a separate electrically operated means for operating the type bars, a contact member adapted to successively engage the said contacts, the said contact member and legend disk being relatively movable, a source of electrical energy connected in series with the contact member, and in parallel with the means for individually operating the type bars.

5. In an automatic printing machine, a plurality of symbol carrying members, a plurality of solenoids, a member adjacent each solenoid which is adapted to be moved as the solenoid is energized, means connecting each of the said members with an indi-

vidual symbol carrying member, a legend member provided with a series of contacts, said contacts being each connected with the windings of a separate solenoid, a contact member adapted to successively engage the aforesaid contacts, the said contact member and legend member being relatively movable, and a source of electrical energy connected in series with the contact member and in parallel with the windings upon the solenoids.

6. In a typewriter, the combination with a plurality of type bars, a plurality of solenoids, a member adjacent each solenoid and adapted to be moved as its solenoid is energized, operative connections between each of said members, and an individual type bar, a legend disk having a series of contacts, each contact being electrically connected with the winding upon one of the solenoids, a contact member adapted to successively engage the said contacts, the said contact member and legend disk being relatively movable, and a source of electric energy connected in series with the contact member and in parallel with the winding upon each solenoid.

7. In an automatic printing machine, a plurality of symbol carrying members, a plurality of solenoids, each of said solenoids being provided with a movable central core, means connecting each of said cores with an individual symbol carrying member, a legend member provided with a series of contacts, said contacts being individually connected with the windings of a separate solenoid, a contact member adapted to successively engage the aforesaid contacts, the said contact member and legend member being relatively movable, and a source of electrical energy connected in series with the contact member and in parallel with the windings upon each solenoid.

8. In a typewriter, the combination with a plurality of type bars, a plurality of solenoids, each solenoid being provided with a movable core, operative connections between each core and an individual type bar, a legend disk having a series of contacts, each contact being electrically connected with the winding upon one of the solenoids, a contact member adapted to successively engage the said contacts, the said contact member and legend disk being relatively movable, and a source of electrical energy connected in series with the contact member, and in parallel with the winding upon each solenoid.

9. In a typewriter, the combination with a plurality of type bars, a plurality of solenoids, a member adjacent each solenoid which is adapted to be moved as its solenoid is energized, operative connections between each of said members and an individual type bar, a legend disk stationarily mounted, a plurality of contact members carried by said

disk, electrical connections between each of said disks and the winding upon one of the solenoids, a contact member adapted to successively engage each of the said contacts, means for causing said contact member to rotate, and a source of electrical energy connected with the solenoids and with the movable contact member.

10. In a typewriter, the combination with a plurality of type bars, a plurality of electromagnetic devices, each of said devices being operatively connected with a type bar so as to move the same when the device is electrically energized, a legend disk having a series of contacts, each of said contacts being electrically connected with the winding upon one of the electromagnetic devices, a contact member adapted to successively engage the contacts on the disk, and a source of electrical energy connected in series with the contact member and in parallel with the windings upon each of the electromagnetic devices.

11. In a typewriter, the combination with a plurality of type bars, a plurality of electromagnetic devices, operative connections between each electromagnetic device and a type bar whereby the type bar will be operated as the electromagnetic device is energized, a plurality of legend disks, each disk having a series of contacts thereon, electrical connections between each contact on the disks and the windings upon one of the electromagnetic devices, a shaft, a plurality of contact members carried by said shaft, there being one contact member adjacent each disk, said contact member being adapted to engage in succession the contacts upon the disk, means for rotating said shaft, a source of electrical energy connected in series with the contact member and in parallel with the windings upon each of the electromagnetic devices.

12. In a typewriter, the combination with a plurality of type bars, a plurality of electromagnetic devices, each of said devices being operatively connected with one of the type bars, a legend disk, a series of contact upon said legend disk, electrical connections between each of said contact members and one of the electromagnetic devices, a contact member adapted to engage each of the contacts upon the disks in succession, means for moving said contact member, a plurality of switches, the closure of one of said switches causing the means for moving the contact member to operate, another of said switches closing the circuit through the contact member, a member adapted by its movement to cause said switches to successively close, and a source of electrical energy connected in series with the contact member and in parallel with the winding upon each of the electromagnetic devices.

13. In an automatic printing machine, a

plurality of symbol carrying members, electrically actuated means for individually operating said symbol carrying members, a legend member having a series of contacts, each contact being electrically connected to a separate means for operating the symbol carrying members, a contact member adapted to successively engage the said contacts, the said contact member and legend member being relatively movable, a circuit connected with a source of electrical energy, and connected in series with the contact member and in parallel with the means for individually operating the symbol carrying member, means for closing the circuit, and means for holding the circuit closed throughout a printing operation, said means automatically opening the circuit when the printing is complete.

14. In an automatic printing machine, a plurality of symbol carrying members, electrically actuated means for individually operating said symbol carrying members, a legend member having a series of contacts, each contact being electrically connected to a separate means for operating the symbol carrying members, a contact member adapted to successively engage the said contacts, the said contact member and legend member being relatively movable, a motor for causing the relative movement between the legend member and contact member, a circuit connected with a source of electrical energy and connected in series with the contact member and in parallel with the motor, and the means for individually operating the symbol carrying member, means for closing the circuit, and means for maintaining said circuit closed during a printing operation and automatically opening the circuit at the completion of the printing.

15. In a typewriter, the combination with a plurality of type bars, a plurality of electromagnetic devices, each of said devices being connected with a type bar, a legend disk having contacts thereon, each of said contacts being connected with the winding upon one of the electromagnetic devices, a movable contact member adapted to engage the contacts upon the said disks in succession, means for causing said contact member to move, a source of electrical energy connected in series with the contact member and in parallel with the winding upon each of the electromagnetic members, said source of electrical energy also being connected in series with the means for causing the contact member to move, a plurality of switches, one of said switches lying in circuit with the movable contact member, the other of said switches lying in circuit with the means for causing the contact member to move, a member adapted to engage said switches to cause them to successively contact.

16. In a typewriter, the combination with

a plurality of type bars, a plurality of electromagnetic devices, each of said devices being connected with a type bar, a legend disk having contacts thereon, each of said contacts being connected with the winding upon one of the electromagnetic devices, a movable contact member adapted to engage the contacts upon the said disks in succession, means for causing said contact member to move, a source of electrical energy connected in series with the contact member and in parallel with the winding upon each of the electromagnetic members, said source of electrical energy also being connected in series with the means for causing the contact member to move, a plurality of switches, one of said switches lying in circuit with the movable contact member, the other of said switches lying in circuit with the means for causing the contact member to move, a member adapted to engage said switches, to cause them to successively contact, and means for retaining the member which engages the said switches to hold said switches closed while the contact member successively engages the contacts on the disk.

17. In a typewriter, the combination with a plurality of type bars, a plurality of electromagnetic devices, each of said devices being connected with a type bar, a legend disk having contacts thereon, each of said contacts being connected with the winding upon one of the electromagnetic devices, a movable contact member adapted to connect the contacts upon the said disks in succession, means for causing said contact member to move, a source of electrical energy connected in series with the contact member and in parallel with the winding upon each of the electromagnetic members, said source of electrical energy also being connected in series with the means for causing the contact member to move, a plurality of switches arranged adjacent each other, one of said switches lying in circuit with the movable contact member, another of said switches lying in circuit with the means for moving the contact member, a relay, an armature adapted to be moved as the relay

is energized, said armature by its movement being adapted to engage the said switches to close the same, said relay being electrically connected with the source of electrical energy, and means for closing the circuit through the said relay.

18. In a typewriter, the combination with a plurality of type bars, a plurality of electromagnetic devices, each of said devices being operatively connected with one of the type bars, a legend disk having a series of contacts thereon, each contact being electrically connected with the winding upon one of the electromagnetic devices, a segmented contact strip carried by said disk, a movable contact member adapted to successively engage the said contacts, and also to engage with the segmented contact strip, means for moving said contact member, a source of electrical energy connected in series with the contact member, also with the means for causing the moving of the contact member and with the segmented contact strip, said source of electrical energy being connected in parallel with the windings upon the electromagnetic devices, a relay, an armature for said relay, a plurality of switches lying in the path of movement of the armature, one of said switches being connected in series with the movable contact member, another of said switches being connected in series with the means for causing the movement of the contact member, and another of said switches being connected in series with the winding upon this relay, a switch for directly connecting the winding upon the relay with the source of electrical energy, whereby the armature of the relay is depressed and the aforesaid switches are closed, the armature being retained in depressed position while the contact member successively engages the contacts upon the legend disk.

In testimony whereof, I hereunto affix my signature in the presence of two witnesses.

ARTHUR R. BULLOCK.

Witnesses:

N. C. HUBBARD,
A. J. HUDSON.