



US 20080153676A1

(19) **United States**
(12) **Patent Application Publication**
Krietzman

(10) **Pub. No.: US 2008/0153676 A1**
(43) **Pub. Date: Jun. 26, 2008**

(54) **DYNAMIC VARIABLE WEIGHT EXERCISE DEVICE AND METHOD**

Related U.S. Application Data

(60) Provisional application No. 60/877,122, filed on Dec. 22, 2006.

(76) Inventor: **Mark H. Krietzman**, Palos Verdes Estates, CA (US)

Publication Classification

(51) **Int. Cl.**
A63B 21/06 (2006.01)
(52) **U.S. Cl.** 482/93
(57) **ABSTRACT**

Correspondence Address:
GREENBERG TRAUER LLP (LA)
2450 COLORADO AVENUE, SUITE 400E,
INTELLECTUAL PROPERTY DEPARTMENT
SANTA MONICA, CA 90404

A hand held ring exercise device and method of use with an internal channel containing a weighted flowable particulate media. By moving the ring device a user exercises against a flowing mass of particulate within the ring which is subject to continuous change. Variable center of weights allows a user to exercise against different apparent weights.

(21) Appl. No.: 11/744,194

(22) Filed: May 3, 2007

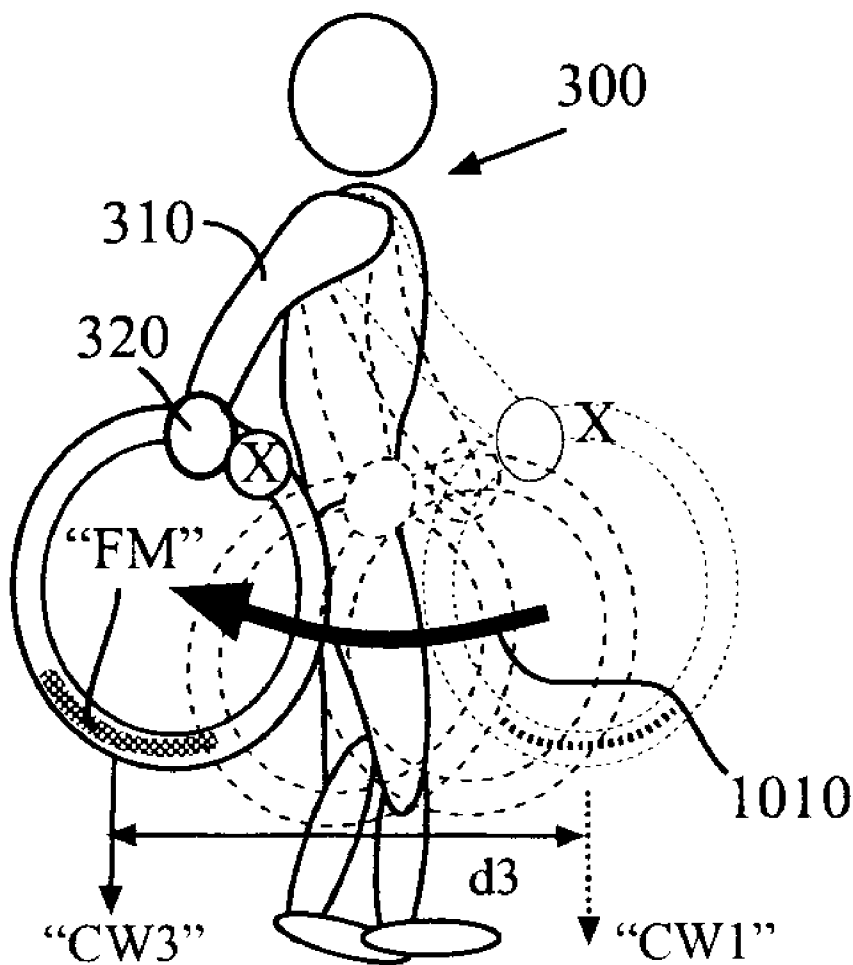

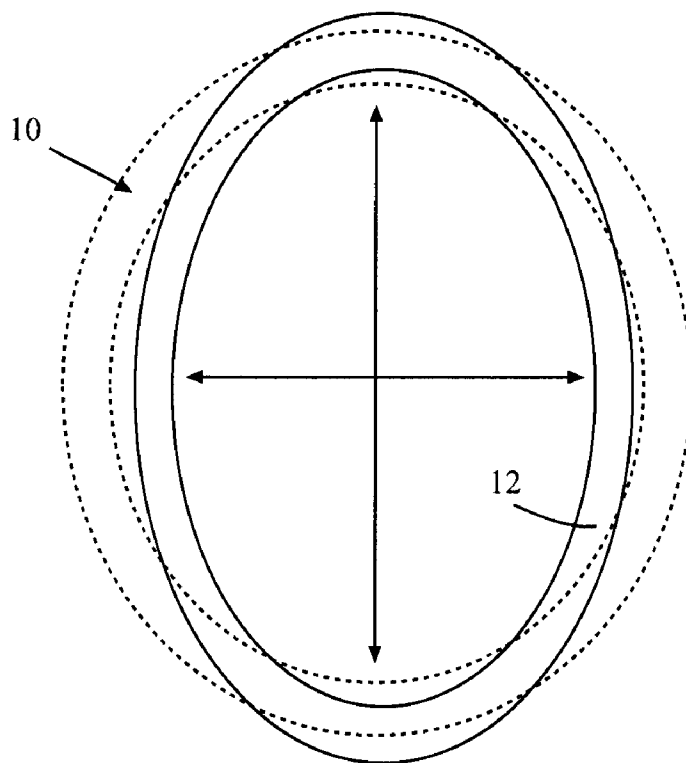

FIG. 1

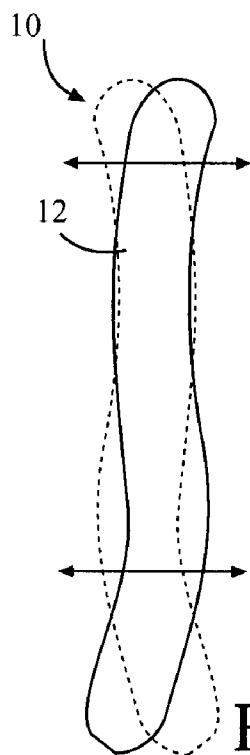

FIG. 2

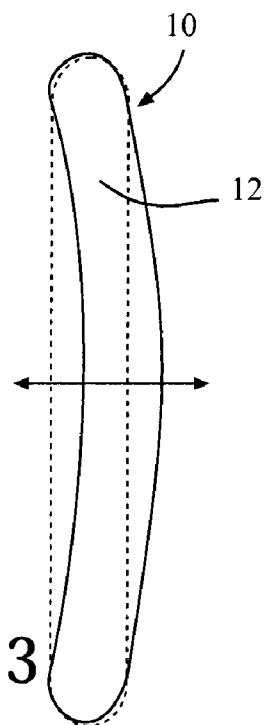
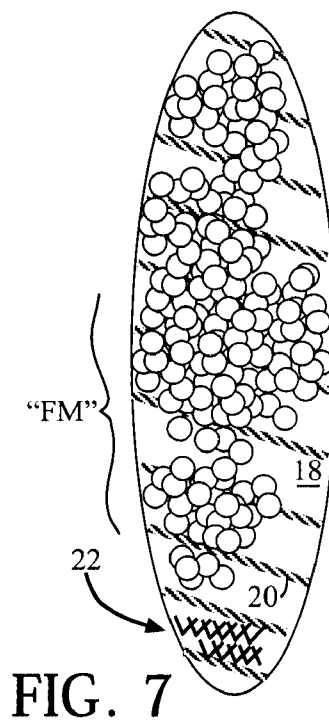
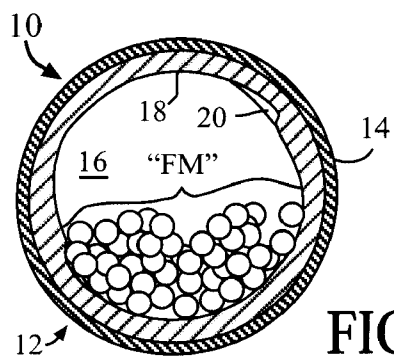
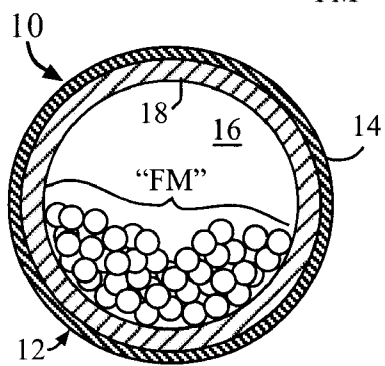
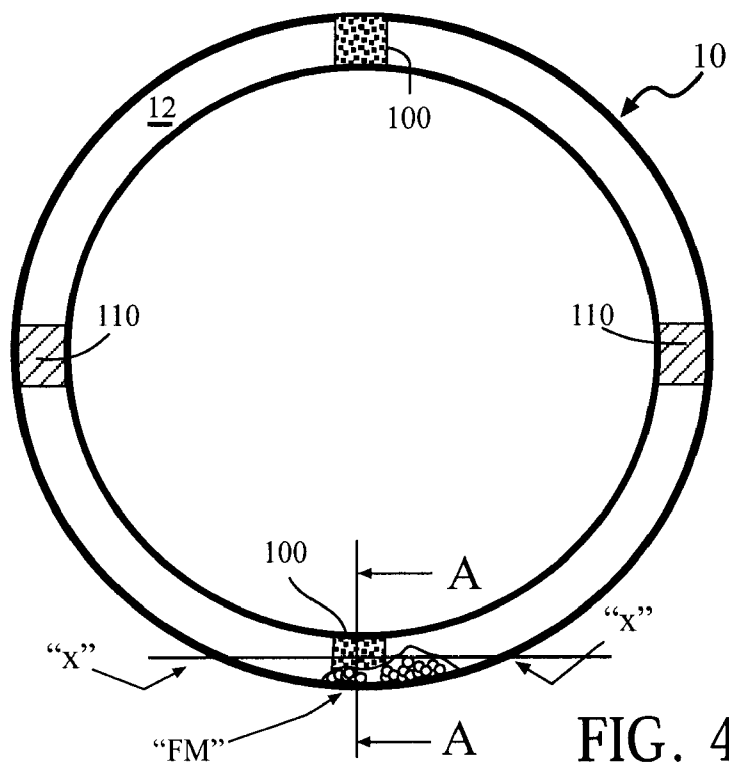

FIG. 3



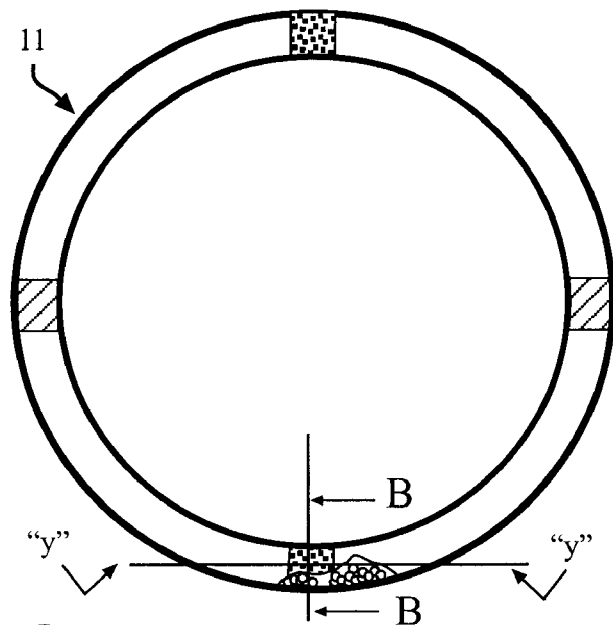

FIG. 8

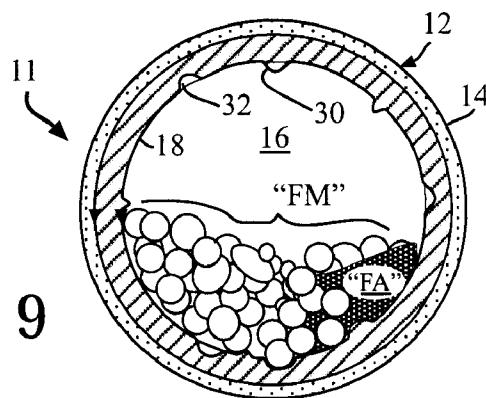

FIG. 9

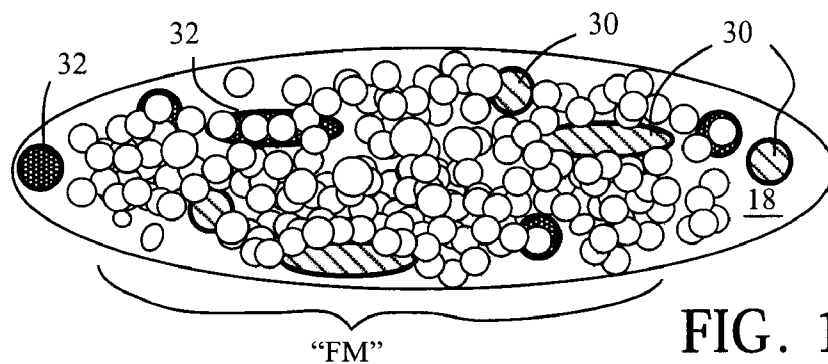

FIG. 10

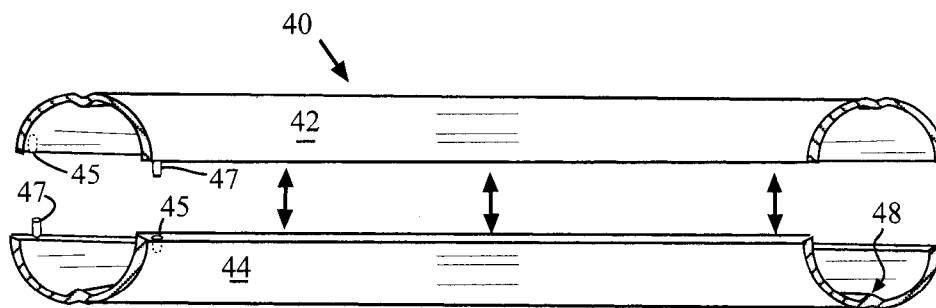

FIG. 11

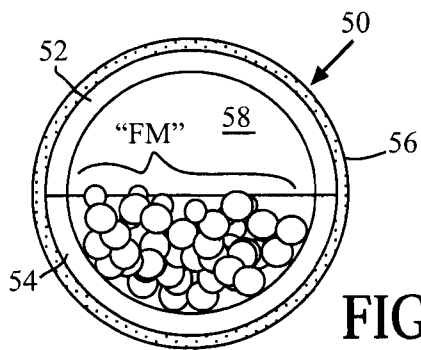

FIG. 12

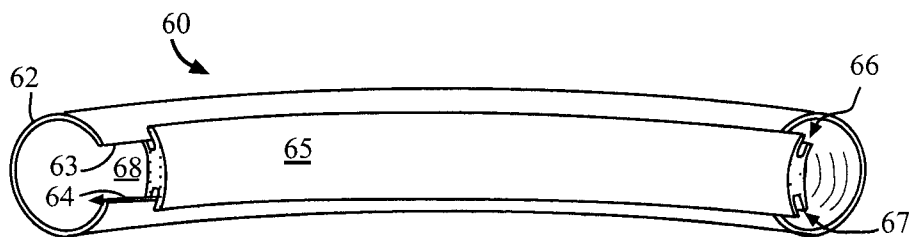

FIG. 13

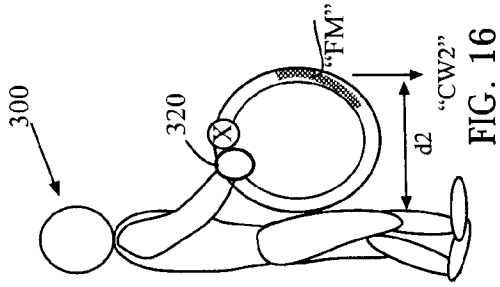

FIG. 14

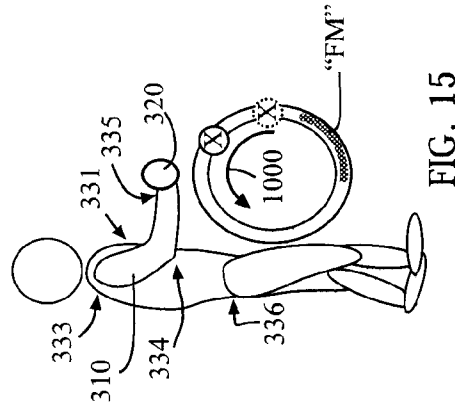

FIG. 15

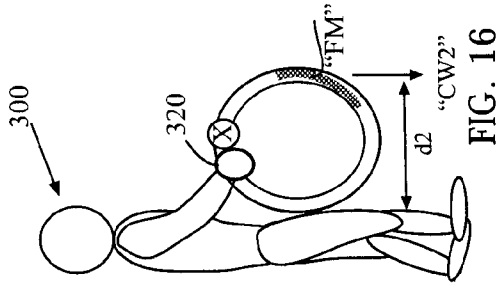

FIG. 16

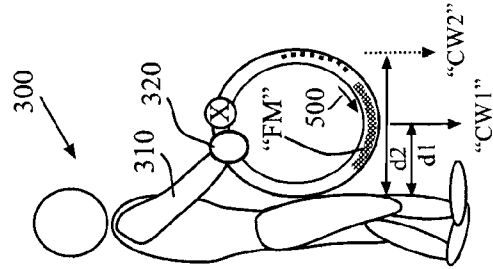

FIG. 17

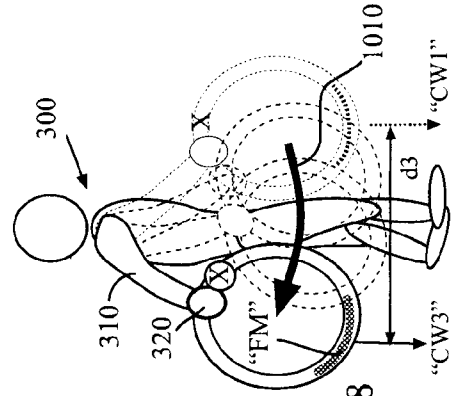

FIG. 18

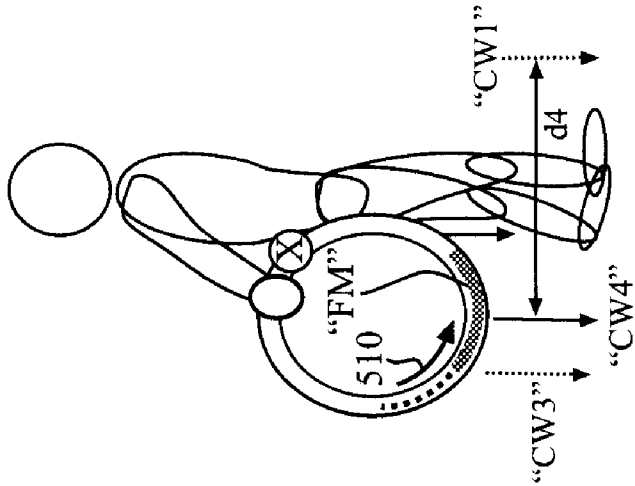

FIG. 19

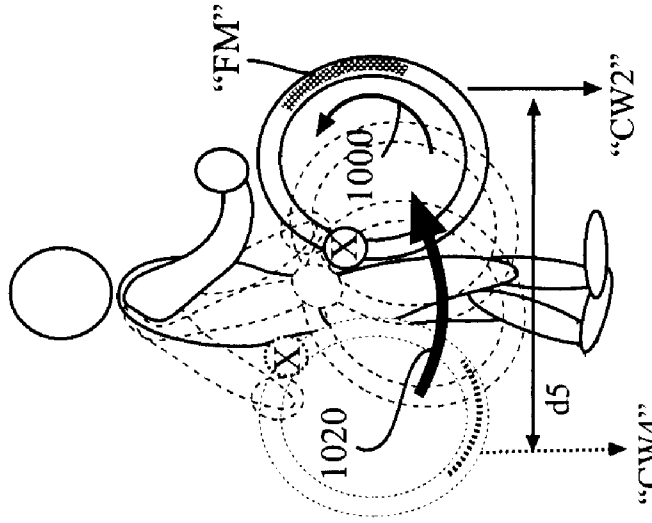

FIG. 20

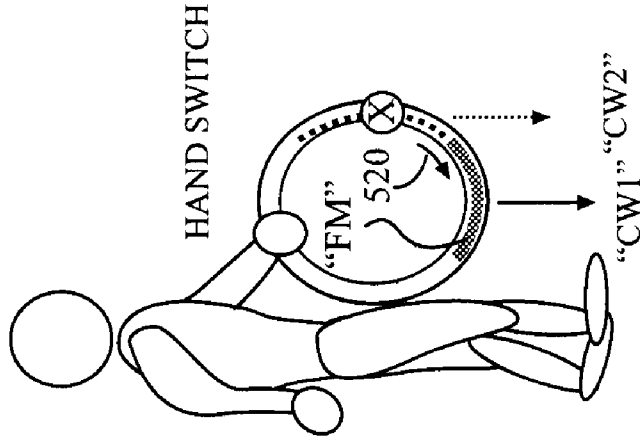

FIG. 21

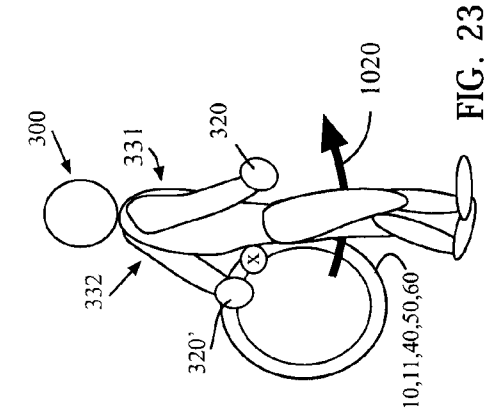

FIG. 23

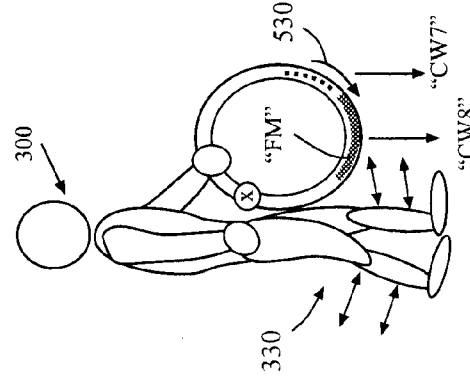

FIG. 25

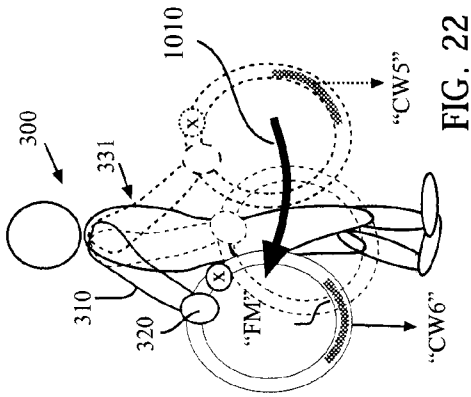

FIG. 22

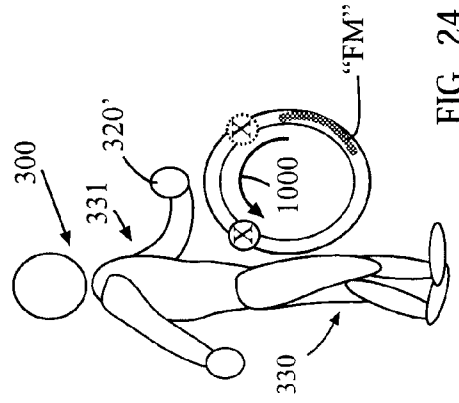

FIG. 24

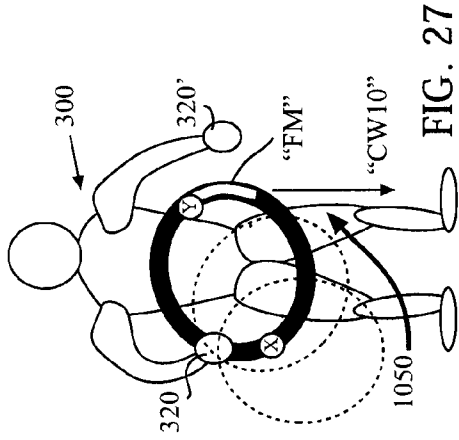

FIG. 27

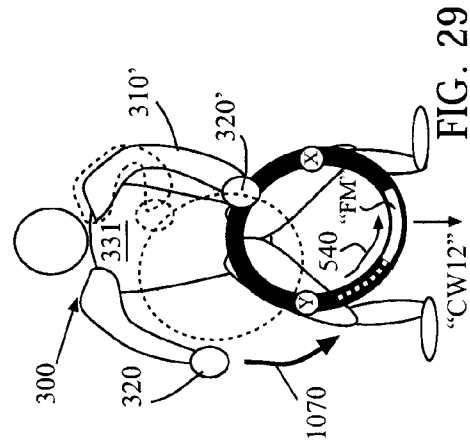

FIG. 29

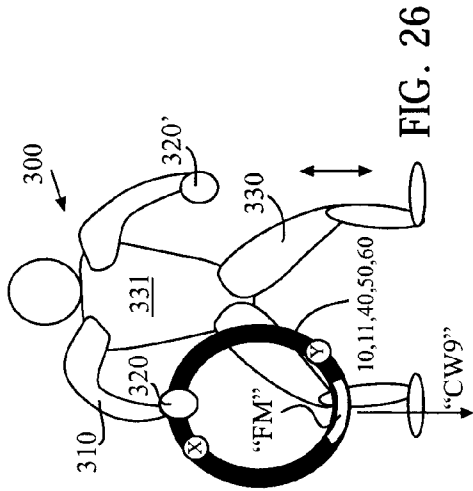

FIG. 26

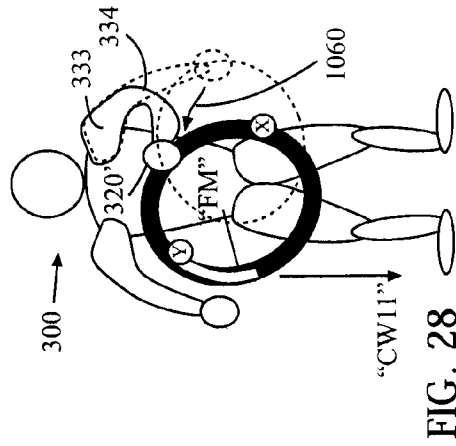

FIG. 28

DYNAMIC VARIABLE WEIGHT EXERCISE DEVICE AND METHOD

RELATED APPLICATION

[0001] This application claims the benefit under 35 U.S.C. Section 119(e) of provisional Application Ser. No. 60/877, 122 entitled "Variable Weight Inertial Dampened Exercise Loop Device and Method" filed Dec. 26, 2006 which is incorporated by reference herein.

BACKGROUND

[0002] 1. Field of the Invention

[0003] This present invention relates to dynamic variable weight (DVW) exercise device and method of use. More specifically, to a continuous body, such as a closed loops, containing at least a flowable particulate to provide forces to exercise with.

[0004] 2. Background Art

[0005] Tai Chi is a system of controlled movements which when properly executed is believed by practitioners to develop the internal life energy or "Chi" of the practitioners. Tai Chi is suitable for all age groups, is non-jarring and can build stamina and strength. Tai Chi movements derive from a concept of "yin" and "yang" which roughly means opposing forces, smooth fluid controlled movements are a hallmark of Tai Chi Learning the controlled Tai Chi movements is accomplished through repetitive practice.

[0006] Benefits of Tai Chi are said to include greater muscle tone, balance and energy. Tai Chi also provides aerobic exercise, strengthening and muscle development.

[0007] Moving with or against the inertia of an element, opponent or device, is a practice to develop balance and core strength. In Tai Chi, the activity is also known as "Push Hands". Hand held free weights, linear sticks, or other weighted devices have fixed weight do not vary in response to movement of the user. Linear bars and with falling weighted interior parts have ends that limit the weight movement.

[0008] It is therefore a desideratum to have an exercise method and device which encourages at least dynamic variable weight (DVW) exercise.

Definitions

[0009] The term "dynamic" as used in "dynamic variable weight (DVW)" means "subject to continuous change, activity, or progress".

[0010] The phrase "dynamic variable weight (DVM)" means "a movable mass (weight) subject to continuous change, activity, or progress".

[0011] The phrase "flowable particulate media (FM)" means an aggregate of particles each particle having mass and the particles capable of moving together as a group in which the movement together promotes friction, impacts, collisions, destructive and/or constructive interferences between the particles which affects the group movement of the particles.

SUMMARY OF THE DISCLOSURE

[0012] A hand held continuous channel device having dynamic variable weight (DVW) center of weight.

[0013] A hand held continuous channel device having DVW via the movement of weighted flowable particulate media.

[0014] A hand held continuous channel device having DVW via the movement of weighted flowable particulate media in response to the movement of the device.

[0015] A method of exercise including at least the steps of hand grasping a continuous channel device containing a DVW flowable particulate media, releasing the device in mid-air while imparting rotation and then catching the device.

[0016] A method of exercise including at least the steps of hand grasping a continuous channel device containing a DVW flowable particulate media, releasing the device in mid-air while imparting rotation, catching (regrasping) the device and holding the device allowing the flowable particulate media to flow in the continuous channel thereby altering the apparent center of weight of the device.

[0017] A method of exercise including at least the steps of hand grasping a continuous channel device containing a DVW flowable particulate media, releasing the device in mid-air while imparting rotation, catching (regrasping) the device and holding the device allowing the flowable particulate media to flow in the continuous channel whereby the rotation repositioned the DVW flowable particulate media within.

[0018] A method of exercise including at least the steps of hand grasping a continuous channel device containing a DVW flowable particulate media, releasing the device in mid-air while imparting rotation, catching (or grasping) the device and holding the device allowing the DVW flowable particulate media to flow in the continuous channel whereby the rotation repositioned the flowable particulate media from a higher potential to a lower potential.

[0019] A method of exercise including at least the steps of hand grasping a continuous channel device containing a DVW flowable particulate media with a first hand, tossing and releasing the device in mid-air while imparting rotation, catching (regrasping) the device with a second hand and holding the device allowing a flowable particulate media with DVW to flow in the continuous channel altering the apparent center of weight of the device.

[0020] A method of exercise including at least the steps of hand grasping a continuous channel device containing a DVW flowable particulate media with a first hand, tossing and releasing the device in mid-air while imparting rotation, catching (regrasping) the device with a second hand and holding the device allowing the flowable particulate media to flow in the continuous channel whereby the rotation repositions a particulate flowable media with DVW which flows from a higher potential to a lower potential.

[0021] An hand held exercise body of one or more of rigid, semi-rigid, flexible, body sections forming a continuous channel or track.

[0022] An hand held exercise body of one or more of rigid, semi-rigid, flexible, body sections forming a closed channel wherein a particulate flowable media with DVW can flow.

[0023] A hand held exercise device with at least one of a guide, track and channel wherein a DVW flowable particulate media is placed.

[0024] A hand held exercise device with at least one of a guide, track and channel wherein a DVW particulate media is placed. The media flow being reactive at least in part to the movement of the device.

[0025] A hand held exercise device with at least one of a guide, track and channel in which a DVW flowable particulate media flows over a surface of the interior of the guide and that interior surface affects the flow.

[0026] In one aspect, the flow of a DVW particulate media within a closed channel device alters the apparent center of weight of the device, relative to a selected point.

[0027] In one aspect, the flow of a DVW particulate media within a closed channel device alters the apparent center of weight of the device, relative to a selected point, via the interior diameter of one or more regions in the closed channel of the device.

[0028] In some exemplary implementations the flow of a DVW particulate media within a closed channel device alters the apparent center of weight of the device, relative to a selected point, via the interior features of the inside of the channel which include but are not limited to plastic and/or fiber texture, ribs, wells, dimples, bumps, walls, slots, coils, gaps, tracks, coils, ledges, guides and the like.

[0029] The flowable media is a weighted particulate that maybe homogenous or non-homogeneous in composition, size, weight and shape.

[0030] In one aspect the flowable particulate media may be combined with granules, powder, powdered graphite, powdered lubricants, dehydrating compounds, desiccant material and/or anti-clumping material.

[0031] In one aspect, the particulate flowable media within the exercise device may be combined with viscous fluid and/or lubricants.

[0032] In some exemplary implementations exercise is achieved by using at least one hand and arm to impart rotation to a hand held ring-like device whereby the center of weight of the device is altered corresponding to at least in part the location and or movement of the weighted flowable particulate media therein.

[0033] In some exemplary implementations exercise is achieved by at least waist twisting, hand to hand passing, and rotating of a hand held ring-like device wherein the movement of the flowable media varies and revaries the apparent center of weight of the device during use.

[0034] Other features and advantages of the present disclosure will be set forth, in part, in the descriptions which follow and the accompanying drawings, wherein embodiments and some exemplary implementations are described and shown, and in part, will become apparent to those skilled in the art upon examination of the following detailed description taken in conjunction with the accompanying drawings or may be learned by practice of the disclosure. Advantages may be realized and attained by means of the instrumentalities and combinations of elements and instrumentalities particularly pointed out in the appended claims.

BRIEF DESCRIPTIONS OF THE DRAWINGS

[0035] The above-mentioned features and objects of the present disclosure will become more apparent with reference to the following description taken in conjunction with the accompanying drawings wherein like reference numerals denote like elements and in which:

[0036] FIGS. 1-3 are external views of a hand held closed loop exercise device.

[0037] FIGS. 4-7 are front and cut-away views of a hand held closed loop exercise device.

[0038] FIGS. 8-10 are front and cut-away views of a hand held closed loop exercise device.

[0039] FIGS. 11-13 are partial assembly and cut-away views of another hand held closed loop exercise device.

[0040] FIGS. 14-21 show a sequence of uses of a hand held closed loop exercise device.

[0041] FIGS. 22-25 show a sequence of uses of a hand held loop exercise device.

[0042] FIGS. 26-29 show a sequence of uses of a hand held loop exercise device.

[0043] It should be appreciated that for simplicity and clarity of illustration, elements shown in the Figures have not necessarily been drawn to scale. For example, the dimensions of some of the elements are exaggerated relative to each other for clarity. Further, where considered appropriate, reference numerals have been eliminated on repeated elements, or in some case repeated among the Figures to indicate corresponding elements.

DETAILED DESCRIPTION OF THE EXEMPLARY IMPLEMENTATIONS

[0044] Detailed exemplary implementations are disclosed herein; however, it is to be understood that the disclosed items are merely exemplary implementations of the disclosure. The disclosure may be embodied in various forms and combination of forms. Therefore, specific structural and functional details disclosed herein are not to be interpreted as limiting, but merely as a basis for claims and as a representative basis for teaching one skilled in the art to variously employ the disclosure in virtually any appropriately detailed structure.

[0045] Shown in FIGS. 1-3 are external views of a loop exercise device 10. The loop exercise device 10 has a loop body 12 which borders (or forms) a loop channel (not shown). The loop body may be a single unitary structure that is rigid, semi-rigid or flexible. The loop body may alternatively have sections that are one or more of rigid, semi-rigid or flexible in the same device. FIGS. 2 and 3 are side views of a not completely rigid variation of the device. The degree of flexibility of the loop body, if any, will impact the movement and rate of movement of a flowable particulate media within the loop exercise device.

[0046] Shown in FIGS. 4-7 are views of an exercise loop device. FIG. 4 shows a partially exploded exterior view of a loop body 12. Coded external regions 100 & 110 are shown as being at about 90 degree separation from each other. That 90 degree separation is not a limitation and is merely for reference, more or fewer coded regions may be used and they may be in evenly or unevenly spaced positions. A coded regions may be visually coded by color, by pattern. Other examples coding include, but are not limited to, tactile by material, patterning, or brush-like texture such as fibers or tufts. A tactile coding may be by surface texture, softness or diameter. The coded regions may be integral to the loop body 12 or they may be attached. A flowable particulate media "FM" is within the loop body 12.

[0047] Shown in FIGS. 5 and 6 are cut away views at line A-A. FIG. 5 shows the exercise loop body 12 as a body layer 14 of the loop device 10 bordering a loop channel 16 with an intervening channel layer 18. The two layer structure of loop body 12 and channel layer is not a limitation and the loop body 12 bordering the loop channel 166 may be a single layer multiple layers. A channel layer 18 may be integral with the body layer 14. The loop body 12 may be constructed out of round, ovoid, and ellipse; geometric or other cross sectional structures.

[0048] Constructions options may include molding, milling, blow molding, injection molding, vacuum forming, layering, vulcanizing rubber, and extruding. Inside the loop channel 16 is the flowable particulate media "FM" which is in contact with the channel layer 18. The flowable media is a

non-aqueous weighted particulate. The flowable particulate media "FM" may be homogenous and/or non-homogeneous in composition, size, weight and shape. Beads or balls of about 1/16 to 1 and 1/4 inch diameter may be suitable particulate depending on the channel size. Balls or beads in the 1/4 inch to 3/4 inch are more preferred. Particulate which is too small tends to pack and bind within a flow channel.

[0049] Shown in FIGS. 6-7 is are cut-away view at line A-A and X-X, respectively, of FIG. 4. The channel layer 18 is indicated to have a regularly textured surface with raised or lowered ridges 20 which may traverse all or a portion of the channel layer 18. Although indicated as a spiral in FIG. 7 the raised or lowered ridge 20 may be a repeating or non-repeating pattern such as rings or spirals. Rings may also be oriented perpendicular to the diameter of the loop channel 16 or parallel to the loop channel. A textured region 22 which may be constructed of plastic tufts, or other material bristles or brushes can be added. The purpose of the raised or lowered ridge and the textured region is to impact the movement of the flowable particulate media "FM" inside the loop channel 16.

[0050] Shown in FIGS. 8-10 is another hand held exercise device 11. The exercise loop 11 is shown cut-away at line B-B of FIG. 8 in FIG. 9 and cut-away at line Y-Y of FIG. 8 in FIG. 10. Inside the exercise loop device of FIG. 10 are surface features of the inner layer (shown as a channel layer 18—but which can also be the inner layer of the body layer 14 or the loop body can actually be the exterior of the channel layer). The surface features shown in these figures may also be combined with the surface feature of raised or lowered ridges shown in FIG. 5-7.

[0051] In FIGS. 9 and 10 the surface features are shown as raised dimples, ridges or bumps 30 and lowered wells, divots or dimples 32. The purpose of the bumps 30 or dimples 32 is to impact the movement of the flowable particulate media "FM" inside the loop channel 16. Flow additives "FA" may be added to the flowable particulate media "FM". Flow additives "FA" may include powders, lubricants, anti-clumping chemical, dehydration chemicals, anti oxidant chemicals, viscous fluid, and other chemical or small granular material like sand.

[0052] FIG. 11 shows an exemplary implementations of assembly of a hand held ring-like exercise devices. In FIG. 11 a ring-like exercise device 40 is formed from a two part ring body with a first half 42 and a second half 44. Alignment slots 45 and raised pins 47 that align the first and second halves during assembly are shown. Interior ridges 48 or other previously described flow altering interior features may be added to the interior channel or track of the ring device.

[0053] FIG. 12 is a cut away of a hand held exercise device 50 also formed from a two part ring body with a first half 52 and a second half 54. An outer materials or coating 56 is included. That outer layer 56 may be a dipped coating such as a vinyl (PVC), neoprene, plastic, fabric, or rubber-like material. The outer layer may separate or integrated, an over sleeve or a fixed layer. The flowable particulate media "FM" is shown within the ring channel 58. The outer layer can be added to any of the closed channel hand held devices described within.

[0054] In FIG. 13 another multi-part hand held exercise device 60 is shown. The main wheel body 62 is a configuration suitable for blow molding or vacuum forming with a free first and second edge 63/64. An inner rim area 65 is an extruded or molded part with a first groove 66 and a second groove 67 to receive the first and second edges 63/64 to close

the wheel channel 68 and prevent the departure of the flowable particulate media from the wheel channel.

[0055] FIGS. 14-29 show examples of a discreet uses of hand held loop-like DVW exercise device. Those of ordinary skill in the art will recognize the examples of use are not limiting. Those of ordinary skill in the art will recognize that the alteration or dampened of the flow of the weighted flowable particulate media within the device is suitable to provide DVW as a force to exercise with in many different exercise sequences. This disclosure is not limited to the sequence, or the order of steps in a sequence. Sequences of use illustrate many individual exercises all of which may be used with the DVW hand held exercise loop-like devices disclosed herein. One or more aspects of an exercise sequence (FIGS. 14-21, FIGS. 22-25 and/or FIGS. 26-29) may be combined with other aspects in other sequences or with new moves.

[0056] The flowable particulate media "FM" can alter the center of weight (CW) of a device relative to a selected position of a user. Examples are movements of the center of weight, relative to the user's position, indicated in FIGS. 14-29 as changes of any of center of weight one through center of weight twelve "CW1-CW12". The changes of a center of weight "CW" are gradual and not fixed. The examples of center of weight "CW" called out in the figures at discreet locations are for illustration, the flowable particulate is a DVW media and unless at the point of lowest potential the particulate will move, shift, flow and vary in reaction to movement and position of the loop-like device to seek a lower potential.

[0057] Shown in FIGS. 14-21 is a method of using a hand held loop-like exercise device 10,11,40,50 or 60. Exercise begins with a gripping or holding of the device by a user 300. The user's hand 320/320' grips the device and holds the device above the ground. The user can add roll, spin or rotation to the device by releasing it with a movement of the user's arm 310 and hand 320 imparting a movement towards the front 331 of the user 300 by generally spinning the device along the path of arrow 1000. The flowable particulate media "FM" within a track or channel inside the device (see FIGS. 4-6, 8, 9 and 12) is repositioned along with the spun device.

[0058] Repositioning the flowable particulate media "FM" changes the relative center of weight "CW" of the device. For example, the center of weight shown as the center of weight one "CW1" in FIG. 14 becomes the center of weight two "CW2" in FIG. 16 after the user 300 tosses the device towards the user's front 331. The device has a fixed weight when at rest. During exercise the distance of the center of weight "CW" of the device to the user's body changes, for example from "d1" to "d2" (as the flowable particulate media "FM" inside the device channel is repositioned). The change in distance relocates the center of weight "CW" of the device closer or further from a pivot point (such as the user's shoulder 333, elbow 334, wrist 335, hips 336) which in turn causes the apparent weight of the device the user exercises against to vary. The DVW particulate media flows during the change in distance or position dampens and varies the relocation of the center of weight "CW" and thereby varies the apparent weight. The flow of the particulate provides the DVW which can be a continually varying force (except when at rest) to exercise with.

[0059] The apparent weight of the device (at any give point during movement) is derived from sum of the mass of the flowable media "mFM" and the distance of the center of weight dCW (apparent weight=mFMxdCW) from a pivot

such as the user's, hand, wrist, arm, elbow, shoulder, back, legs, hip etc. Other aspects of the loop-like device such as rigidity or flexibility can alter the flow of the media within the device. Selected features inside the device channel, as discussed above, may be used to impact the flow of the DVW particulate media. The internal structures, coefficient of friction, size and shape of the closed channel as well as the characteristics of the media can be used to enhanced or dampened the device's DVW via the flow of the flowable particulate media "FM".

[0060] Examples of a sequences of exercise is illustrated in FIGS. 11-24. Rotation of the loop-like device around itself is imparted by the user to the device 10, 11, 40, 50 and 60. The path of arrow 1000 is one example of a rotational pathway.

[0061] Called out as a positional identifier, in some figures, are an "X" or an "X" and "Y" indications on the device. To aid understanding the disclosure the positional identifier indicates relative positions of the device to the user's hand 320/320' and body, the flowable particulate media "FM" within a device. The flowable particulate media "FM" has inertia and depending on the variables such as flowable particulate media "FM" size, shape, contours and composition (such as particulate, granular, metal, stone, plastic, bead, pellet, BB, ball bearing, pebble and sand) and the surface features and sizes of the channel or channels inside the device, the flowable particulate media "FM" will not necessarily move linearly with the swinging, spinning, rotating or rolling of the device.

[0062] Rotation relocates the body of the loop-like device (as shown by the location of identifiers "X"). The position the flowable particulate media "FM" within the device is repositioned as the loop-like device is rotated. A flick of the user's grasped hand upward or downward can be used to urge or toss the device upward, forward and/or backward to reposition the device as shown by the movement off "X" in FIGS. 14 and 29. The sequence shown continues with a user catching (grasping) the device after tossing it. Repositioning of the flowable particulate media "FM" may also be achieved by transferring the momentum of a swing, or via a swing with a grasped hand 320 and then ungrasping the hand 320 while the loop device hangs in mid air or moves loosely within the user's substantially ungrasped hand 320 as illustrated in FIGS. 15, 20, 24 and 27-29.

[0063] Movements includes all around the user. Movements may come from the front of the user 331 to back of the user 332 along the line of arrow 1010, or from the back of the user 332 to the front of the user 331 along the line of arrow 1020. By swinging the device (FIGS. 18, 20, 22, 27 and 28) momentum is imparted to the device. When the user goes through, all or part of, the sequence of swing, rotation, ungrasp and then catch (regrasp) the device conserves the moment of swing by imparting the rotation or roll and the flowable particulate media "FM" inside the device is repositioned (see generally FIGS. 12, 17, 19, 21, 25 and 29) along with the device. Following a swing, even if a user then holds the device in a fixed position, any repositioned flowable particulate media "FM", at a higher potential due to the repositioning of the device, will flow (towards the lowest (nearest to the ground) region of the loop device) thereby affecting the center of weight.

[0064] In FIG. 11-16 flowable particulate media "FM" is at center of weight one "CW1" and center of weight two "CW2". Exercise is achieved by swinging the device from front to back of the user's body 300 as shown in FIGS. 14-21 wherein the center of weight "CW" is moved to different

distances (d1-d5). The center of weight "CW" is shown altered between center of weight one "CW1", center of weight two "CW2, center of weight three "CW3" and center of weight four "CW4" (and all positions there between). After a repositioning of the flowable particulate media "FM" the media being dynamic gently alters the center of weight by flowing to a lower potential as indicated by arrows 500, 510, and 520. The swing from back to front of the user's body 300 may be added to a exercise set, or a stand-alone exercise. The relocation of the DVW particulate media shown from center of weight four "CW4" back to center of weight one "C1" illustrated in FIGS. 15-17 completes a sequence any part of which may be a stand alone use and/or which may be combined with other sequences. A hand off of the device from hand 320 to hand 320' either in front of the body or behind the back is also illustrated in FIGS. 14-25.

[0065] During a use, the center of weight "CW" is adjustable through one or more of the movement of the loop device. The center of weight "CW" is also altered by the movement and position of the parts making up the DVW of the flowable particulate media "FM". Any of the exercise illustrated herein may be repeated on either side of the body with the flowable particulate media "FM" moving within the device (such as along the line of arrows 500, 510, 520, 530 and 540) resulting in a change in the apparent weight of the device relative to the user.

[0066] The flowable particulate media "FM" has weight and therefore it has potential. The repositioning of the flowable particulate media "FM" can change the potential of the loop-like device. As the flowable articulate media "FM" seeks a lower potential, the user, by repositioning the mass of flowable particulate media "FM" rotation of the body, can raise the inertial mass from low to higher potential—the DVW results from the mass of flowable particulate media "FM" moving between states of potential.

[0067] Many of the exercise movements shown in FIGS. 11-25 may include the use of a hand held device in each hand 320/320'. When using two hand held devices together the user may swing hands, arms and hand held devices therein in phase with (both rings reaching the end of a swing (either front or back) at approximately the same time) or the arm hand device movement may be out of phase wherein one device will reach the end of its swing path 1010 or 1020 at substantially before the other device reaches the end of its swing path.

[0068] FIGS. 26-29 show a sequential front located exercise. The loop-like exercise device 10, 11, 40, 50, and 60 are shown with identifiers "X" and "Y". The identifiers represent fixed positions on the device body and are provided to compare the positions of the body, the flowable particulate media "FM" and the user (including the user's appendages such as arms 310, legs 330 and hands 320). The device with a flowable particulate media "FM" within may be passed in front of a user 300 from hand 320 to hand 320'. The loop body may be lifted up and down, swung around a swing path as indicated by arrows 1050, 1060 and 1070, passed from hand 320 to hand 320' and/or spun (transition from FIG. 27 to 28). The various movement activities act to alter the center of weight "CW" of the device from center of weight nine through center of weight 12 "CW9-CW12".

[0069] Since certain changes may be made in the above apparatus without departing from the scope herein involved, it is intended that all matter contained in the above descrip-

tion, as shown in the accompanying drawing, and in the appended claims shall be interpreted in an illustrative, and not a limiting sense.

[0070] While the apparatus and method have been described in terms of what are presently considered to be the most practical and preferred embodiments, it is to be understood that the disclosure need not be limited to the disclosed embodiments. It is intended to cover various modifications and similar arrangements included within the spirit and scope of the claims, the scope of which should be accorded the broadest interpretation so as to encompass all such modifications and similar structures. The present disclosure includes any and all embodiments of the following claims.

1. A method of dynamic variable weight exercise comprising:

a user grasping in a hand a ring with an internal channel containing a weighted flowable particulate media comprising the steps of:

- A. swinging the ring along the side of the user's body;
- B. ungrasping the ring in mid air and spinning the ring and weighted flowable particulate media within towards the user's body;
- C. catching the ring in mid air; and,
- D. grasping the ring and allowing the weighted flowable particulate media, that was relocated during the rotation, to flow.

2. The method of claim 1 wherein the user repeats steps A-D.

3. The method of claim 1 the method further comprising the user moving at least one leg forward or back during at least one of steps A-D.

4. The method of claim 1 wherein the user ungrasps and catches the ring using different hands.

5. A method of dynamic variable weight exercise the method comprising:

a user grasping in a hand a weighted ring with a channel containing a weighted flowable particulate media;
 the user rotates the ring containing the weighted flowable particulate media backwards towards the user's body;
 the user releases the ring in mid air;
 the user allows the ring to rotate in mid air, thereby raising the potential of the weighted flowable particulate media within;
 the user catches the ring, after the ring has rotated; and, while grasping the caught ring the weighted flowable particulate media moves inside the ring to a lower potential.

6. The method of claim 5 wherein the user ungrasps and catches the ring with different hands.

7. A method of dynamic variable weight exercise comprising the steps of:

- A. a user holds a weighted ring with a closed channel containing a weighted flowable media in each hand;
- B. the user swings each ring front to back along the user's sides;
- C. the user tosses one ring while imparting a rotation to the ring;
- D. the user catches the tossed ring and continues to swing the ring as the flowable particulate media within flows;
- E. the user tosses the other ring while imparting a rotation to that ring; and,
- F. the user catches the other tossed ring and continues to swing that ring as the flowable particulate media within flows.

8. The method of claim 7 wherein the user swings the rings out of phase with each other.

9. The method of claim 7 wherein the user swings the rings in phase with each other.

* * * * *