

Aug. 20, 1940.

H. KIELBERG

2,212,476

MULTIPLE PAIL

Filed Dec. 8, 1937

2 Sheets-Sheet 1

Fig. 1.

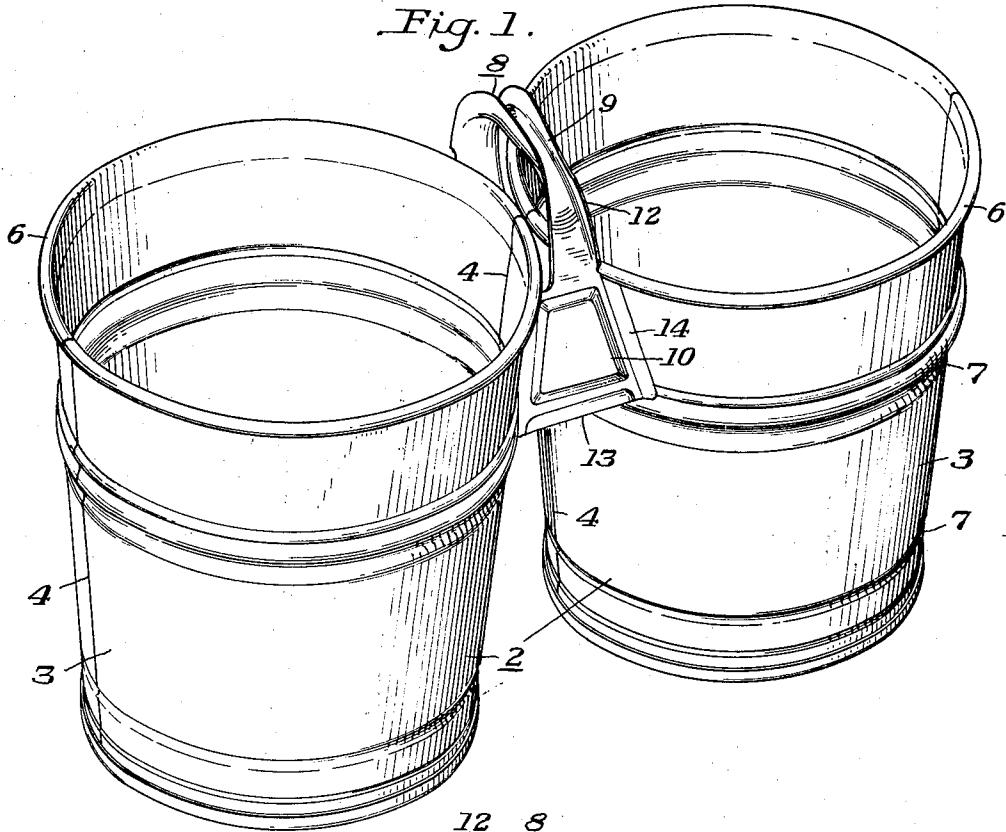
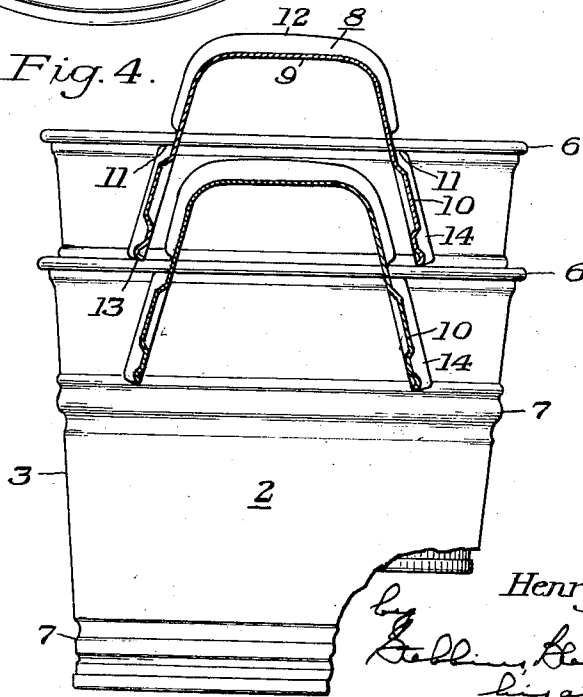

Fig. 4.



INVENTOR

Henry Kielberg

by *Edling, Benson, Samuelson*  
his attorney

Aug. 20, 1940.

H. KIELBERG

2,212,476

MULTIPLE PAIL

Filed Dec. 8, 1937

2 Sheets-Sheet 2

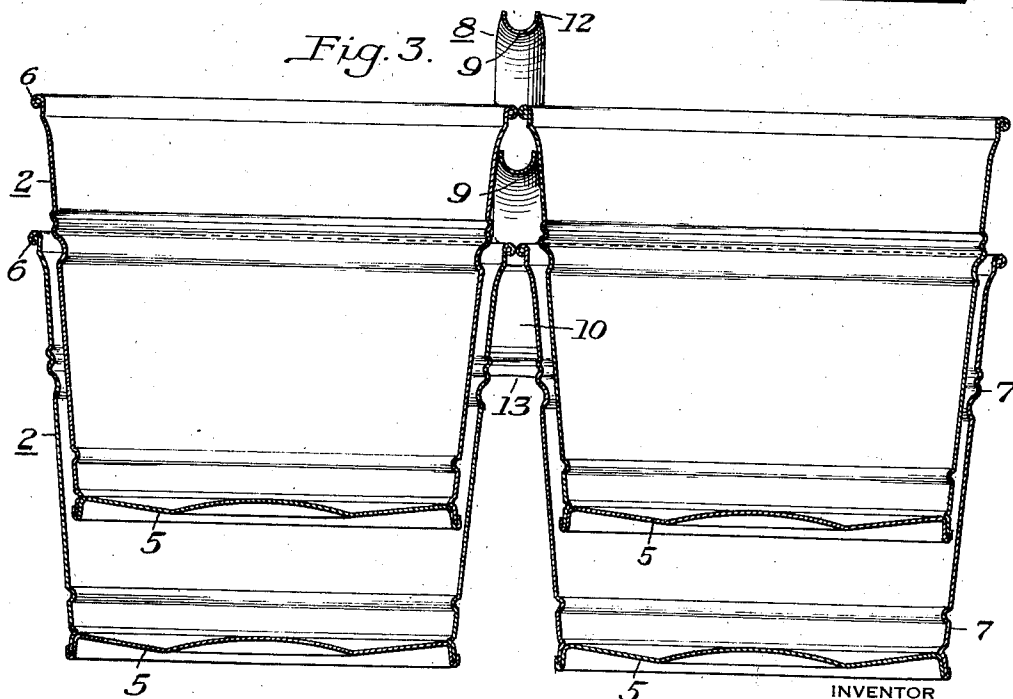
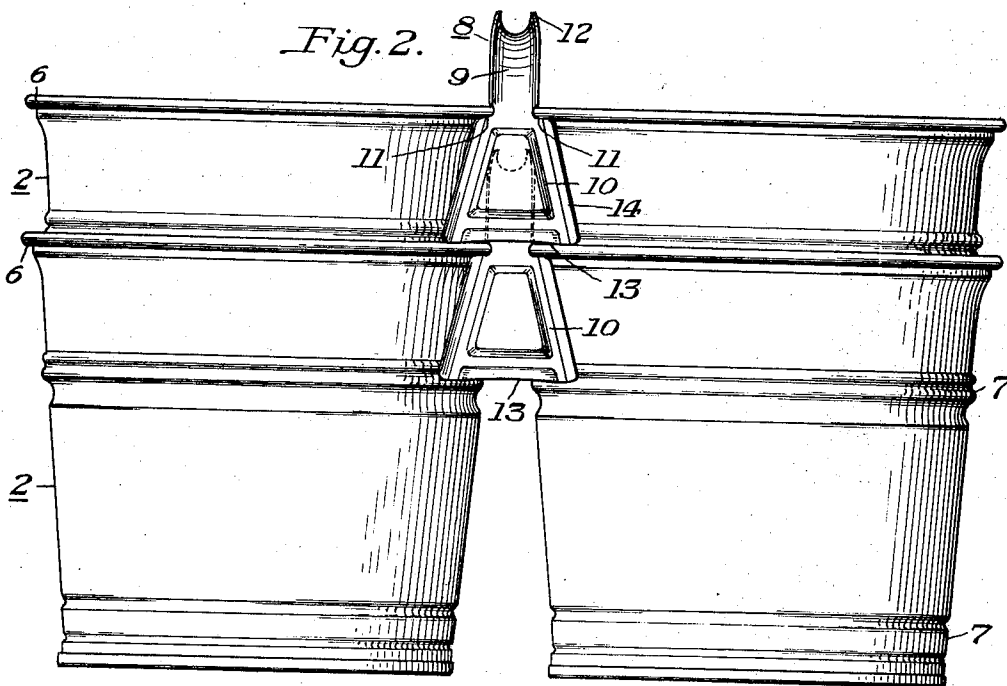

INVENTOR

Henry Kielberg

by *William James Dunne*  
his attorney

# UNITED STATES PATENT OFFICE

2,212,476

## MULTIPLE PAIL

Henry Kielberg, Martins Ferry, Ohio, assignor to  
Wheeling Steel Corporation, Wheeling, W. Va.,  
a corporation of Delaware

Application December 8, 1937, Serial No. 178,710

6 Claims. (Cl. 220—94)

This invention relates broadly to multiple pails, and more particularly to multiple pails such as are used for household and cleaning purposes. It relates still more particularly to a stackable or nestable multiple pail which can be fabricated at exceptionally low cost and which has important advantages in utility.

Multiple pails of various types have heretofore been made, but they have all, so far as I am aware, been subject to certain disadvantages. One of the primary disadvantages of such pails has been that they have not been nestable or stackable like ordinary single pails. This has ordinarily been due to the fact that nesting or stacking of multiple pails has been prevented by the very shape or construction thereof or by the nature and location of the handle member or both.

Nestability of metal ware of the type above referred to is highly important in shipping. If the ware can be nested the cost of shipping is very much lower than if it cannot be nested, as the space consumed is reduced to a fraction of the space necessarily consumed without nesting, and also lower transportation rates obtain and less expensive means of packing need be employed. The problem of designing a nestable multiple pail has long existed in the art, as multiple pails have been used for many years, but so far as I am aware this problem has never been satisfactorily solved prior to the present invention.

I provide a multiple pail comprising a plurality of pail members and handle means for the multiple pail, the pail members and handle means being connected together in such a way that the multiple pail may be nested or stacked with respect to other similar multiple pails. I preferably employ ordinary full round tapered pails and connect them together with their open tops lying substantially in the same plane and with handle means connected thereto and extending thereabove, the bottoms of the pail members being spaced apart to receive the handle of a similar multiple pail when the first mentioned multiple pail is stacked upon the second mentioned multiple pail. The handle means is preferably designed so as to offer a minimum of interference to full access to both pails when the multiple pail is in use and it offers a sturdy and convenient manner of carrying the multiple pail.

Other details, objects and advantages of the invention will become apparent as the following description of a present preferred embodiment thereof proceeds.

In the accompanying drawings I have shown a

present preferred embodiment of the invention, in which

Figure 1 is a perspective view of a multiple pail;

Figure 2 is an elevational view of two multiple pails such as the multiple pail shown in Figure 1 stacked or nested one upon or within the other;

Figure 3 is a central longitudinal cross-sectional view through the two stacked or nested multiple pails shown in Figure 2; and

Figure 4 is a central transverse cross-sectional view through the two stacked or nested multiple pails shown in Figure 2.

Referring now more particularly to the drawings, there are provided two full round sheet metal pails 2 which may be of ordinary construction. As shown in the drawings these are standard seamed and swaged sheet metal pails having bottoms seamed thereto and having the usual wire top rims. Indeed they are preferably identical with ordinary single pails as now on the market save that the bail ears and bails employed on ordinary single pails are not provided. The pails 2 are preferably taken off the regular standard pail production line in the pail factory prior to attachment of the bail ears and bails. This avoids the necessity of making special pails for my multiple pail and hence greatly reduces the cost of the multiple pail.

In the pails 2 the side walls are shown at 3, they being seamed together in usual manner at 4. The bottoms of the pails are shown at 5 and the wire rims at 6. The side walls or bodies 3 of the pails are swaged as shown at 7 whereby to strengthen them relatively to similar unswaged pails. The fact that the pails 2 are of circular cross section rather than of non-symmetrical cross section, as has ordinarily been the case in the provision of pail members for multiple pails, enables the pails 2 to be swaged on the ordinary rotary swaging dies employed in pail factories.

In making my multiple pail two or more of the pails 2 may be employed, two of such pails being employed in the embodiment shown in the drawings. The pails are positioned with their top rims substantially coplanar and substantially in contact. I prefer that the top rims shall be in actual contact, but improved results of my invention are obtained if they are spaced slightly apart. I then provide and connect to the two pail members 2 a common handle and connecting member designated generally by reference numeral 8.

The common handle and connecting member 8 is preferably blanked out of sheet metal and

stamped and formed to the shape shown in the drawings. When so formed it comprises an upper or grip portion 9 and two similar opposed depending connecting portions 10. Each of the portions 10 extends generally downwardly and somewhat outwardly relatively to the pail members 2 as shown in Figure 4. It is made gradually tapered to greater width from its upper portion downwardly so as to fit between and lie against the opposed side faces of the pail members 2. Opposed shoulders 11 are provided at the upper portions of the respective connecting portions 10, and these shoulders 11 directly underlie and contact with the under faces of the rims 6 of the pail members 2 whereby to afford a measure of support for the pail members independently of the welded connections between the connecting portions 10 and the pail members, as will presently be described.

The grip portion 9 of the member 8 has the metal at its side edges turned upwardly as shown at 12 whereby to strengthen and stiffen the member 8 and provide a smooth comfortable grip portion. The grip portion is of least width at its center and its width gradually increases from the center toward both ends of the member 8, as shown in Figures 1 and 2. This not only makes the grip portion exceptionally comfortable when the multiple pail is being carried, but also provides for conformation of the grip portion with the exteriors of the pail members of a similar multiple pail when the second mentioned multiple pail is stacked on the first mentioned multiple pail. This conformation may be understood from the shape of the grip portion 9 as shown in Figure 1 and also from Figures 2 and 3 in which (as is also the case in Figure 4) two identical multiple pails are shown stacked or nested one upon or within the other. As the two multiple pails are identical the reference numerals apply equally to them both.

When the multiple pails are stacked the bottom edges 13 of the respective portions 10 of the member 8 of the upper multiple pail rest upon the rims of the pail members 2 of the lower multiple pail as shown in Figures 2 and 4. The bottoms of the pail members 2 of the upper multiple pail enter the upper portions of the pail members 2 of the lower multiple pail. The grip portion 9 of the member 8 of the lower multiple pail lies between the pail members 2 of the upper multiple pail and intermediate the portions 10 of the member 8 of the upper multiple pail. The grip portion 8 is preferably so designed, as indicated above, that it will fit snugly and conform to the opposed faces of the pail members of a multiple pail stacked upon the multiple pail of which it is a part. Thus the grip portion positions the two multiple pails relatively to one another horizontally whereas the vertical positioning thereof is effected by the lower edges 13 of the portions 10 of the member 8 of the upper multiple pail. As shown in the drawings, the lower edges 13 of the portions 10 of the member 8 of the upper multiple pail rest on the rims 6 of the pail members of the lower multiple pail and thus prevent sticking of the multiple pails when nested.

The member 8 is preferably connected with the pail members 2 by spot welding each of the portions 10 to each of the pail members along the respective edge portions 14 thereof. This provides a strong permanent union and adapts the multiple pail to be carried by the common handle and connecting member 8 while main-

taining the respective pail members 2 in their proper relative positions even when they are filled with water or other liquid. The multiple pail is preferably galvanized or otherwise suitably dip coated, and I prefer to do this after assembly of the pail members 2 and the member 8 and the spot welding together thereof, as the coating covers the welding. However, the individual pail members 2 and the member 8 may, if desired, be individually coated and then connected together.

As will be seen from Figure 1, the handle member is so positioned and is of such character that it does not materially interfere with access to both of the pails throughout their respective entire cross-sectional areas. Thus, even though full round pails are preferably employed, their manner of connection and support is such that their complete individual utility is not impaired.

My multiple pails are, as above described and as shown in the drawings, stackable or nestable so that they can be shipped, stored and displayed in stacked or nested relationship. Any desired number of the multiple pails may be stacked or nested together and they may conveniently be stacked for shipment in dozen lots. The multiple pails in each lot or stack may be held together by the simple expedient of passing a cord or wire over the grip portion 9 of the top multiple pail so that it lies between the opposed portions 12 thereof and thence downwardly and under the connecting member of the lowermost multiple pail.

The word "pail" is used herein as a word of broad definition and not of limitation and is not intended to be limited to the specific type of container which is commonly referred to commercially as a pail.

While I have shown and described a present preferred embodiment of the invention, it is to be distinctly understood that the invention is not limited thereto but may be otherwise variously embodied within the scope of the following claims.

I claim:

1. A nestable double pail comprising a pair of pails each of smaller dimension at the bottom than at the top and an integral connecting and carrying member comprising a pair of opposed connecting portions disposed respectively on opposite sides of a plane containing the axes of the pails and connecting the pails to form a double pail unit and a handle portion for carrying the double pail unit extending between the respective connecting portions, the lower portions of the pails being spaced apart a distance sufficient to receive the handle portion of a similar double pail to permit nesting.

2. A nestable double pail comprising a pair of pails each of smaller dimension at the bottom than at the top, and a generally U-shaped member arranged with its ends extending generally downwardly and with each of said ends connected with each of the pails whereby to form a double pail unit, the intermediate portion of said member extending above the top rims of the pails and serving as a handle for the double pail unit, the lower portions of the pails being spaced apart a distance sufficient to receive the handle portion of a similar double pail to permit nesting.

3. A nestable double pail comprising a pair of pails in side-by-side relation, each of smaller dimensions at the bottom than at the top, a handle member positioned between said pails and

5 securing them rigidly together, said handle member comprising a substantially horizontal hand grip portion disposed above the pails and portions connected to the hand grip portion adjacent  
10 its ends extending downwardly therefrom between the pails, said downwardly extending portions being rigidly connected to both pails, the said downwardly extending portions being spaced apart a distance greater than the length of the  
15 hand grip portion and securing said pails in sufficiently spaced relation below the tops thereof to receive the hand grip portion of a similar double pail to permit nesting.

4. A nestable double pail comprising a pair of  
15 pails in side-by-side relation, each of smaller dimensions at the bottom than at the top, a handle member positioned between said pails and securing them rigidly together, said handle member comprising a substantially horizontal hand  
20 grip portion disposed above the pails and portions connected to the hand grip portion adjacent its ends extending downwardly therefrom between the pails, said downwardly extending portions being rigidly connected to both pails, the  
25 said downwardly extending portions being spaced apart a distance greater than the length of the hand grip portion and securing said pails in sufficiently spaced relation below the tops thereof to receive the hand grip portion of a similar double  
30 pail to permit nesting, said hand grip portion being shaped to engage the adjacent walls of a superimposed double pail when nested and thus laterally position the pails relative to each other.

5. A nestable double pail comprising a pair of  
35 pails in side-by-side relation, each of smaller dimensions at the bottom than at the top, a handle

member positioned between said pails and securing them rigidly together, said handle member comprising a substantially horizontal hand grip portion disposed above the pails and portions connected to the hand grip portion adjacent its ends  
5 extending downwardly therefrom between the pails, said downwardly extending portions being rigidly connected to both pails and bridging the space therebetween, the said downwardly extending portions being spaced apart a distance greater  
10 than the length of the hand grip portion and securing said pails in sufficiently spaced relation below the tops thereof to receive the hand grip portion of a similar double pail to permit nesting,  
15 said downwardly extending portions of the handle member of said double pail contacting the upper edges of an adjacent lower double pail when nested and supporting said first mentioned double pail thereon.

6. A nestable double pail comprising a pair of  
20 pails each of smaller dimension at the bottom than at the top and a connecting and carrying member comprising a pair of opposed upwardly extending elements disposed respectively on opposite sides of a plane containing the axes of the  
25 pails and rigidly connecting the pails together in side-by-side relation to form a double pail unit and a handle portion for carrying the double pail unit extending between the respective upwardly  
30 extending elements and connected to the upper ends thereof, the lower portions of the pails being spaced apart a distance sufficient to receive the handle portion of a similar double pail to permit nesting.

HENRY KIELBERG. 35