

(12) INTERNATIONAL APPLICATION PUBLISHED UNDER THE PATENT COOPERATION TREATY (PCT)

(19) World Intellectual Property Organization
International Bureau



(43) International Publication Date
21 December 2000 (21.12.2000)

PCT

(10) International Publication Number
WO 00/77609 A1

- (51) International Patent Classification⁷: G06F 7/50, 15/00, 17/00, 17/21, 17/28
- (21) International Application Number: PCT/US00/16482
- (22) International Filing Date: 14 June 2000 (14.06.2000)
- (25) Filing Language: English
- (26) Publication Language: English
- (30) Priority Data: 60/138,979 14 June 1999 (14.06.1999) US
- (71) Applicant (for all designated States except US): THE THOMSON CORPORATION [US/US]; Metro Center, One Station Place, Stamford, CT 06902 (US).
- (71) Applicant and
(72) Inventor: ZAHARKIN, Michael, S. [US/US]; 25 Archer Road, Rochester, NY 14624 (US).
- (74) Agent: VIKSNINS, Ann, S.; Schwegman, Lundberg, Woessner & Kluth, P.O. Box 2938, Minneapolis, MN 55402 (US).
- (81) Designated States (national): AE, AG, AL, AM, AT, AU, AZ, BA, BB, BG, BR, BY, CA, CH, CN, CR, CU, CZ, DE, DK, DM, DZ, EE, ES, FI, GB, GD, GE, GH, GM, HR, HU, ID, IL, IN, IS, JP, KE, KG, KP, KR, KZ, LC, LK, LR, LS, LT, LU, LV, MA, MD, MG, MK, MN, MW, MX, MZ, NO, NZ, PL, PT, RO, RU, SD, SE, SG, SI, SK, SL, TJ, TM, TR, TT, TZ, UA, UG, US, UZ, VN, YU, ZA, ZW.
- (84) Designated States (regional): ARIPO patent (GH, GM, KE, LS, MW, MZ, SD, SL, SZ, TZ, UG, ZW), Eurasian patent (AM, AZ, BY, KG, KZ, MD, RU, TJ, TM), European patent (AT, BE, CH, CY, DE, DK, ES, FI, FR, GB, GR, IE, IT, LU, MC, NL, PT, SE), OAPI patent (BF, BJ, CF, CG, CI, CM, GA, GN, GW, ML, MR, NE, SN, TD, TG).
- Published:
— With international search report.
- For two-letter codes and other abbreviations, refer to the "Guidance Notes on Codes and Abbreviations" appearing at the beginning of each regular issue of the PCT Gazette.

(54) Title: SYSTEM FOR CONVERTING DATA TO A MARKUP LANGUAGE

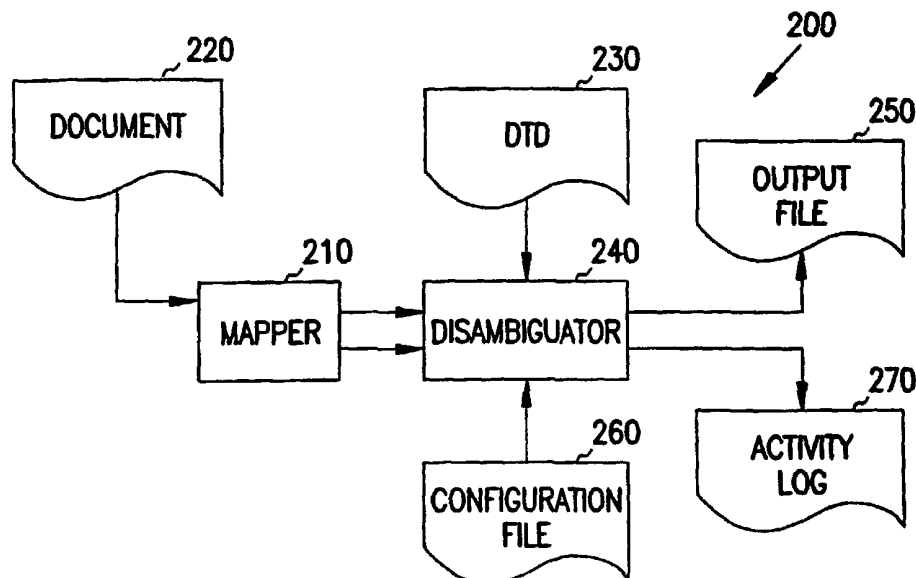

(57) Abstract: A set of systems and methods are provided for parsing data utilizing a document type definition. A list of possible paths of non-compliant document type definition input elements is generated, and a path indicative of a best fit for a document type definition is determined, including parsing said path against the document type definition. The element is then generated in the syntax of the document type definition. The best fit is expressed as a scoring scale in which the best score indicates the best fit. The system utilizes a disambiguator (240), which receives data from a document (220), a mapper (210), a DTD (230), and a configuration file (260) to produce an output file (250). A history is recorded by way of an activity log (270).

WO 00/77609 A1

5

SYSTEM FOR CONVERTING DATA TO A MARKUP LANGUAGE

RELATED APPLICATION

This application claims the benefit of U.S. Provisional Application Serial
10 Number 60/138,979 filed June 14, 1999 under 35 U.S.C. 119(e), and which is
incorporated herein by reference.

TECHNICAL FIELD

This invention concern methods of converting electronic documents from
15 one format to another format, particularly methods of converting documents to a
Standard Generalized Markup Language (SGML) or an Extensible Markup
Language (XML).

BACKGROUND OF THE INVENTION

20 Some electronic documents include text and annotation elements which
indicate the semantics, hierarchy, structure, or format of the documents. The
annotation elements, known as markups, within a document generally conform
to a markup language which defines a set of annotation elements. The markup
language defines which elements in the are required elements, which elements
25 are optional elements, and how annotation elements distinguish from
neighboring text. Examples of markup languages include Standard Generalized
Markup Language (SGML), Extensible Markup Language (XML), and hypertext
markup language (HTML).

30 Additionally, electronic documents with markups are also associated with
document type definition (DTD). The DTD for a particular document defines
the rules and format of the document in terms of a set of declarations for a
markup language, such as SGML or XML. The DTD for the document is either

embedded in the document or resides in a separate document associated the document. The DTD is used in parsing the document, that is, breaking the document into smaller chunks of data for further processing.

Conventionally, marking up documents according a markup language
5 entails inputting the document into a specific custom-conversion program
designed for marking up documents in the markup language. Examples of
custom conversion programs are programs created using tools such as
Omnimark™ and Balise™. Thus, for example, marking up a document in
SGML requires use of an SGML conversion program and marking up a
10 document in HTML requires use of an HTML conversion program. In other
words, the conventional approach to marking up documents using DTD-specific
conversion programs.

This conventional approach suffers from at least five problems. First,
because the converters are dependent on the structure of a single DTD, they
15 cannot be used to markup documents according to other markup languages.
Second, the converter cannot easily adapt to changes to its corresponding DTD,
since the grammatical and semantic rules of the DTD are hard-coded into the
converter, requiring the logic of the converter to be reprogrammed. Third, the
hard-coded DTD semantics in the converter increases its size and complexity,
20 and thus reduce its reliability. Fourth, the dependency of the converter on a
specific DTD also reduces the reusability of its source code for other DTDs.
And fifth, conventional converters follow an all-or-nothing approach to markup,
which prevents them from outputting a document with marked and unmarked
portions. This restriction reduces the flexibility and application of the translator.

25 Accordingly, there is a need in the art for a better ways of marking up
documents.

SUMMARY

To address these and other problems, the inventor devised systems, methods, and software for handling documents with different document type definitions (DTDs.) One exemplary method receives a document and an associated DTD, generates a mapping file from the document and the DTD, with the mapping file having one node representing each possible mapping of an element of the DTD to a portion of the document. The exemplary method further generates one or more paths representing possible paths from one node in the mapping file to another node in the mapping file, scores each possible path, and selects one of the paths based on the scores. Finally, the selected path is converted into a language described by the DTD.

BRIEF DESCRIPTION OF THE DRAWINGS

FIG. 1 is a block diagram of an exemplary computer system incorporating the invention.

FIG. 2 is a block diagram of an exemplary system for disambiguating data according to the invention.

FIG. 3 is a flowchart of an exemplary method for disambiguating data according to the invention.

FIG. 4 is a block diagram of an apparatus of an embodiment of the disambiguator of the present invention.

FIG. 5 is a block diagram of an exemplary method for producing a SGML DTD parseable file of an embodiment of the present invention.

FIG. 6 is a block diagram of an exemplary mapping file data structure incorporating the invention.

FIG. 7 is a block diagram of an exemplary data structure for representing candidate paths of a segment of an element of ambiguated document in an implementation of the invention.

FIG. 8 is a block diagram of an exemplary data structure for representing candidate paths of two contiguous segments of elements of ambiguated document in accord with the invention.

5 **DETAILED DESCRIPTION OF THE PREFERRED EMBODIMENTS**

The following detailed description, which references and incorporates the Figures, describes and illustrates one or more specific embodiments of the invention. These embodiments, offered not to limit but only to exemplify and teach the invention, are shown and described in sufficient detail to enable those skilled in the art to practice the invention. Thus, where appropriate to avoid obscuring the invention, the description may omit certain information known to those of skill in the art.

The detailed description is divided into five sections. The first section describes an exemplary computer system that incorporates the invention. The second section provides a system level overview of the invention. The third section describes examples of methods for an embodiment of the invention. The fourth section describes a particular SGML based implementation of the invention. Finally, the fifth section summarizes some advantages or salient features of the exemplary embodiment.

Exemplary Computer System Incorporating Invention

FIG. 1 is a block diagram of an exemplary computer system (or environment) 100 incorporating the invention. The description of FIG. 1 provides an overview of a computer hardware and a suitable computing environment in conjunction with which some embodiments of the present invention can be implemented. Embodiments of the present invention are described in terms of a computer executing computer-executable instructions. However, some embodiments of the present invention can be implemented entirely in computer hardware in which the computer-executable instructions are implemented in read-only memory. One embodiment of the invention can also be implemented in client/server computing environments where remote devices that are linked through a communications network perform tasks. Program modules can be located in both local and remote memory storage devices in a distributed computing environment.

Computer 110 includes a processor 118, commercially available from Intel, Motorola, Cyrix and others, software 120, and a system bus 126, that operatively couples various system components including the system memory to the processing unit 118. For example, some embodiments implement one or more portions of system 100 using one or more mainframe computers or servers, such as the Sun Ultra 4000 server.

The processor 118 executes exemplary DTD-independent document-conversion software 120. Embodiments of the present invention are not limited to any type of computer 110. In varying embodiments, computer 110 comprises a PC-compatible computer, a MacOS-compatible computer or a UNIX-compatible computer. The construction and operation of such computers are well known within the art.

Furthermore, computer 110 can be communicatively connected to the Internet 130 via a communication device 128. In one embodiment, a communication device 128 is a modem that responds to communication drivers to connect to the Internet via what is known in the art as a "dial-up connection."

In another embodiment, a communication device 128 is an Ethernet or similar hardware (network) card connected to a local-area network (LAN) that itself is connected to the Internet via what is known in the art as a "direct connection" (e.g., T1 line, etc.).

5 Computer 110 can be operated using at least one operating environment to provide a graphical user interface including a user-controllable pointer. Such operating environments include operating systems such as versions of the Microsoft Windows and Apple MacOS operating systems well-known in the art. Embodiments of the present invention are not limited to any particular operating
10 environment, however, and the construction and use of such operating environments are well known within the art.

The computer 110 can operate in a networked environment using logical connections to one or more remote computers. These logical connections are achieved by a communication device coupled to, or a part of, the computer 110.
15 The logical connections depicted in FIG. 1 include a local-area network (LAN) 151 and a wide-area network (WAN) 152.

Exemplary System Level Overview

FIG. 2 shows an exemplary DTD-independent document-conversion
20 system 200 incorporating the present invention. System 200 includes a mapper 210 that receives a document 220 of ambiguated and/or ambiguous data. The mapper 210 creates a mapping file (not shown) from the document 220. The mapping file (not shown) is transmitted to the disambiguator 240. The disambiguator 240 receives the mapping file and the document type definition
25 (DTD) 230. The disambiguator 240 converts the mapping file into an output file 250 that complies with the DTD 230 and/or disambiguates the mapping file in reference to, or based on, the DTD. The disambiguator 240 eliminates the need for specific programmatic solutions. The disambiguator 240 satisfies the need for a DTD-specific or a DTD-dependent translator.

System 200 includes a configuration file 260 that is received by the disambiguator 240 which specifies predetermined settings and/or parameters describing how the disambiguation process of the disambiguator 240 operate. For example, one setting and/or parameter that specifies the markup syntax of the DTD 230 and the output file 250, such as Extensible Markup Language (XML) and/or Standard Generalized Markup Language (SGML).

System 200 also includes an activity log 270 that receives from the disambiguator 240 information that describes the activity of the conversion process of the disambiguator 240, and records the information. The disambiguator 210 can be embodied as computer hardware circuitry or as a computer-readable program, or a combination of both.

System 200 also includes one or more DTDs in addition to DTD 230, which enables selective conversion to one of a plurality of markup languages. DTD input is selected from one of the plurality of DTDs. The indicator of which DTD to select is in the document 220, the configuration file 260, or from a different source.

Exemplary Methods of the Invention

In the previous section, a system level overview of the operation of an embodiment of the invention was described. In this section, the particular methods performed by the server and the clients of such an embodiment are described by reference to a series of flowcharts. Describing the methods by reference to a flowchart enables one skilled in the art to develop such programs, firmware, or hardware, including such instructions to carry out the methods on suitable computerized clients or servers. In computerized clients, one or more processor of the clients execute the instructions from computer-readable media, and in computerized servers, one or more processors of the clients execute instructions from computer-readable media.

FIG. 3 shows an exemplary method 300 for disambiguating data according to the invention. Method 300 is performed by a program executing on,

or performed by firmware or hardware that is a part of, a computer, such as computer 110 in FIG. 1. Method 300 can be embodied on a computer-readable magnetic, electronic, or optical medium comprising computer-executable instructions.

5 Ambiguous or ambiguated data has more than one grammatical or semantic interpretation. Ambiguated data is not parseable because the data does not subscribe to a particular set of grammatical or semantic rules that are used in interpreting the data during parsing. More specifically, ambiguous data is data in which it is not certain which path in the tree structure of the DTD to follow in
10 parsing the document, thus the data is unparseable.

Method 300 includes receiving a document and an associated document type definition (DTD). In varying embodiments, the document is received before, during or after the DTD is received.

Method 300 includes applying markup rules in the DTD to the document
15 305, wherein the markup rules are defined as any programs or pattern-matching processes that can locate the elements of the DTD. The rules must locate the elements in the input file without context of other elements. For example if a rule to locate all “<para>” elements in the input file, when referencing the DTD, the “<para>” element may exist within a “<section>” element and also within a
20 “<chapter>” element. It is frequently necessary to locate the parent elements first, which may in turn have parent elements.

Next, method 300 entails creating a mapping file 310. The mapping file contains all of the locations of the DTD elements in the input file as specified by the markup rules. The mapping file includes one or more nodes, each node
25 representative of a possible mapping of an element of document type definition to a portion of the document. The mapping file is generated from the document and the document type definition

Subsequently, method 300 includes generating one or more candidate paths from the mapping file. Each candidate path represents a possible path
30 from one node in the mapping file to another node in the mapping file.

Subsequently, method 300 includes receiving the candidate paths 315 that compose a segment in the mapping file. A segment is a one or more candidate paths starting with a common node and ending with a common node. Disambiguation begins in action 315.

5 Next, method 300 applies a scoring methodology to the candidate paths 320. A score for each of the one or more candidate paths is determined. In one example, determining one or more scores includes determining two or more scores for each one of the one or more candidate paths and defining the highest of the two or more scores as the determined score for the one of the one or
10 more candidate paths. DTDs are commonly structured as a hierarchical tree, the tree representing the abstract syntax of tokens in the DTD. In another example, determining the score(s) of the candidate path(s) includes parsing the candidate paths against the DTD by traversing the tree structure of the DTD, comparing a candidate path to the DTD and determining if the candidate path is a valid path
15 or not.

Each node in the DTD tree structure represents a DTD element. The DTD tree structure is traversed by picking a unique path in the DTD tree structure starting at the root node and traversing from node to node to an end node in the tree structure. As the DTD tree structure is traversed, the DTD is
20 mapped to a document encoded according to the DTD. At some particular points in the traversal, the path is ambiguous because there is no unequivocal indication from the encoded document of which one of a number of nodes in the DTD to traverse. Ambiguous situations are problematic because that is a lack of certainty as to how to interpret the elements in the encoded document in
25 consideration of the DTD.

The highest score represents the closest match to the current position in the DTD.

Applying a scoring methodology to the candidate paths includes determining a score in reference to, or based on, compliance with the document
30 type definition without inferring additional tags for each of the one or more

candidate paths. More specifically, this action scores a path highly if the path is directly acceptable to the DTD without inferring any additional tags. In two examples, a high score is represented by a "TRUE" in a Boolean scale, or as a score of 100 on a scale of 0 to 100 in which 100 is the highest score.

- 5 Conversely, a path is scored low if the path is not directly acceptable to the DTD without inferring any additional tags. In two examples, a low score is represented by a "FALSE" in a Boolean scale, or as a score of 0 on a scale of 0 to 100 in which 0 is the lowest score.

Alternatively, a score for each of the candidates paths is determined by
10 determining a score in reference to, or based on, compliance with the document type definition with inferring tags for each of the one or more candidate paths. More specifically, this action scores a path highly, such as a score of 99 on a scale of 0 to 100 in which 100 is the highest score, if the path is acceptable to the DTD with tag inference in reference to, or based on, the rules of the markup
15 language of the DTD, such as SGML. Conversely, a path is scored low, such as a score of 0 on a scale of 0 to 100 in which 0 is the lowest score, if the path is not acceptable to the DTD with tag inference in reference to, or based on, the rules of the markup language of the DTD, such as SGML.

Alternatively, a score for each of the candidates paths is determined by
20 determining a score in reference to, or based on, a recursive examination of each path for a predetermined extent from each node in the tree structure of the mapping file for each of the one or more candidate paths. More specifically, acceptable paths are constructed by "looking ahead" to the other nodes in the document to determine if a particular path will lead to an acceptable path. The
25 look-ahead process is controlled by a parameter stored in configuration file that controls how far ahead an attempt to make an invalid path valid is made. This alternative scoring process is a conventional "game tree" action in which a set of N possibilities or the next progression down the tree structure path, each progression is attempted. The scoring process is repeated to determine of the
30 path leads to a successful outcome.

Thereafter, the candidate with the highest score is selected or retrieved
325. Selecting one of the candidate paths based on, or from, the one or more
scores generated in action 320.

A determination as to whether the scores of all the candidate paths
5 indicate no match 330. If the determination is negative, then the method
continues at action 360. Otherwise, the determination is affirmative and method
300 continues with determining whether or not the disambiguation that began at
action 315 must be reset 335. When the determination as to whether or not the
disambiguation must be reset, disambiguation is reset 340 in which all data
10 structures associated with disambiguation are reset, and the method continues
with receiving a list of candidate paths 315. When the determination as to
whether or not the disambiguation must be reset is not affirmative, an attempt to
resynchronized 345 in which a determination as to whether any of the candidates
paths in the segment are valid, in which the last open start-tag is closed, a list of
15 valid start and end tags that can exist in the DTD are received, and a
determination as to whether or not any successful matches to at least one of the
candidates paths exist.

After attempting to resynchronize 345, a determination of the success of
the resynchronization is performed 350. When the determination indicates that
20 the resynchronization is not successful, the method continues in skipping current
candidate paths 355 and the method continues with receiving a list of candidate
paths 315, such as a next list of candidate paths.

When the determination 330 that the scores of all the candidate paths
indicate a match 330, a determination of whether or not there are multiple paths
25 that have equal scores to each other 360 is performed. When the determination
360 indicates that multiple paths have equal scores, then applying tie-breaking to
determine the best path 365 is performed.

When the determination 350 indicates that the resynchronization is
successful, or the determination 360 that there are not multiple paths having
30 equal scores, or the determination 360 that multiple paths have equal scores and

applying score tie-breaking 365 is performed, thereafter, the candidate path with the highest score is converted to SGML and/or XML (SGML/XML) and transmitted to an output file 370. The selected candidate path is converted into a language described by the DTD 230, which could be SGML or XML depending upon whether the DTD 230 specified SGML or XML. More specifically, an element is generated that complies with the markup language described by the DTD.

Subsequently, a determination of whether more candidates exist in the mapping file 375. If the determination that more candidate paths exist in the mapping file, then the method continues with receiving a list of candidate paths 315, such as a next list of candidate paths.

Where the mapping file includes more than one segments, actions 315 – 370 will be repeated for each of the additional segments beyond the first segment, in which generating one or more candidate paths from the mapping file will use a singular segment from the mapping from which to generate candidate paths. A segment is a one or more candidate paths starting with a common solid node and ending with a common terminal node.

SGML/XML Implementation

In FIG. 4, a particular SGML and/or XML (SGML/XML) implementation of the invention is described in conjunction with the system overview in FIG. 2 and the method described in conjunction with FIG. 3 that is SGML/XML related.

Embodiments of the invention are described as operating in a multi-processing, multi-threaded operating environment on a computer, such as computer 110 in FIG. 1.

FIG. 4 is a block diagram of an apparatus 400 of an embodiment of the disambiguator 240 of FIG. 2 of the present invention.

Apparatus 400 includes a permutater 420 of one or more candidate paths 430 from the mapping file 410. The permutater 420 is operatively coupled to the

mapping file 410, with each of the one or more candidate paths 430 representing a possible path from one node in the mapping file 410 to another node in the mapping file 410.

A scorer 440 receives the one or more candidate paths 430 from the
5 permutater, yielding a corresponding number of one or more scores 450.

Apparatus 400 also includes a selector 460 that receives the candidate paths 430, and the one the one or more scores 450, and selects candidate path having the highest score, yielding a selected candidate path.

A converter 480 converts the selected candidate path 470 into an output
10 file 490 encoded in the markup language described by the DTD 495, the markup language being either SGML or XML depending upon which markup language is described by the DTD 495. The converter 480 is operatively coupled to the selector 460 and receives the selected candidate path 470 and also receives the document type definition 495.

15 FIG. 5 is a block diagram of a method 500 for producing a SGML DTD parseable file of an embodiment of the present invention. Method 500 includes receiving a non-SGML document 510. The method also includes receiving a SGML DTD associated with the document 520. In varying embodiments, receiving 510 can be performed before, during or after receiving 520. The DTD
20 may also be embedded in the document. Thereafter, the method includes disambiguating the document in reference to, or based on, the SGML DTD 530. Disambiguating 530 yields disambiguated data. Subsequently, the method includes converting the disambiguated data into a file parseable in reference to, or based on, the SGML DTD 540.

25 FIG. 6 is a block diagram of a mapping file data structure 600 on a computer-readable medium for representing a possible mapping of one or more elements of a document type definition to a portion of a document in an implementation of the invention. The mapping file data structure includes one or more segments, such as a first segment 610 and a second segment 620. A

segment is a one or more candidate paths starting with a common solid node and ending with a common terminal node.

Each of the segments includes a field storing data representing a solid node 630. A solid node 630 is a node encoded in SGML/XML markup language as the node originally existed in the document. The solid node 630 can represent
5 either a SGML/XML start-tag, represent a SGML/XML end-tag, or represent the result of a markup rule locating a single element, such as a SGML/XML start-tag or a SGML/XML end-tag, at the position of the node in the document. The solid node 630 contains the SGML/XML element. One example of a
10 SGML/XML element that a segment could comprise is chapter element.

Furthermore, each of the segments includes a field storing data representing a quantum node, such as quantum nodes 640 of segment1 610 and quantum node 645 of segment2 620. A quantum node is a node that represents multiple alternative tagging options for a single point in the document as created
15 by the markup rules. Quantum nodes 640 and 645 represent two or more of the following: a SGML/XML start-tag, a SGML/XML end-tag, and a SGML/XML end-tag. A full-tag represents the start-tag followed by the content of the start-tag followed by the corresponding end-tag. Quantum node 640 contains one or more SGML/XML elements, such as a section element, a part element or a topic
20 element, where the solid node 630 contains a chapter element. The quantum node 630 of segment 2 620 contain a SGML/XML element.

Each of the segments also includes a field storing data representing a terminal node, such a terminal 650 of segment1 of 610 and terminal node 655 of segment2 620. A terminal node cannot contain further subnodes. The terminal
25 node 650 contains text "Hello World" and the terminal node 655 contains text "some text."

In addition, where the mapping file data structure 600 comprises two or more segments, such as segment 1 and segment 2, and where two contiguous segments, such as segment 1 and segment 2 are joined, in such a manner that the

field storing data representing a terminal node of the first segment is the field storing data representing a solid node of the second segment.

FIG. 7 is a block diagram of a data structure 700 on a computer-readable medium for representing candidate paths of a segment of an element of
 5 ambiguated document in an implementation of the invention.

Data structure 700 is a tree structure that represents the first segment 610 in FIG. 6. Node 710 represents the solid node 630 in FIG. 6. Node 710 is linked to node 720, node 730, and node 740, which represent each of the elements “” “<C>” and “<D>” in quantum node 640 of the first segment 610 in FIG.
 10 6, respectively. Node 750 represents the terminal node 650 of the first segment 610 in FIG. 6.

All permutations of the various paths that can be traversed in data structure 700 are shown in Table 1:

15	<A>Hello World <A><C>Hello World <A><D>Hello World
----	---

Table 1

Table 1 identifies the candidate paths that are scored and from which a candidate path is selected. Each candidate path represents a possible path from
 20 one node in the mapping file to another node in the mapping file data structure 700.

FIG. 8 is a block diagram of a data structure 800 on a computer-readable medium for representing candidate paths of two contiguous segments of elements of ambiguated document in an implementation of the invention. Data
 25 structure 800 is a tree structure that represents the contiguous first segment 610 and second segment 620 in FIG. 6. Node 810 represents the solid node 630 in FIG. 6. Node 810 is linked to node 820, node 830, and node 840, which represent each of the elements “” “<C>” and “<D>” in quantum node 640 of the first segment 610 in FIG. 6, respectively. Node 850 represents the terminal
 30 node 650 of the first segment 610 in FIG. 6. Node 850 is linked to node 860 and

node 870, which represent each of the elements “<X>” and “<Y>” in quantum node 640 of the second segment 620 in FIG. 6, respectively. Node 860 and node 870 are linked to node 880 which represents the terminal node 650 of the second segment 620 in FIG. 6.

5 All permutations of the various paths that can be traversed in data structure 800 are shown in Table 2:

10	<A>Hello World<X>some text <A><C>Hello World<X>some text <A><D>Hello World<X>some text <A>Hello World<Y>some text <A><C>Hello World<Y>some text <A><D>Hello World<Y>some text
----	--

Table 2

Table 2 identifies the candidate paths that are scored and from which a candidate path is selected. Each candidate path represents a possible path from one node in the mapping file to another node in the mapping file data structure 800.

Apparatus 200 and 400 can be embodied on a computer-readable magnetic, electronic, or optical medium comprising computer-executable instructions to perform method 300. Furthermore, data structures 600, 700 and 800 can be embodied on a computer-readable magnetic, electronic, or optical medium.

More specifically, in the computer-readable program embodiment, the programs can be structured in an object-orientation using an object-oriented language such as Java, Smalltalk or C++, and the programs can be structured in a procedural-orientation using a procedural language such as COBOL or C. The software components communicate in any of a number of means that are well-known to those skilled in the art, such as application program interfaces (A.P.I.) or interprocess communication techniques such as remote procedure call (R.P.C.), common object request broker architecture (CORBA), Component

Object Model (COM), Distributed Component Object Model (DCOM), Distributed System Object Model (DSOM) and Remote Method Invocation (RMI) . The components execute on as few as one computer as in computer 110 in FIG. 1, or on at least as many computers as there are components.

5

Conclusion

In furtherance of the art, the inventors have devised systems, methods, and software for generating data parseable against an arbitrary set of one or more document type definitions (DTDs). One exemplary method entails generating a list of a possible paths of an input element of data that is not encoded according to the DTD, determining the path that is the best fit with the DTD, and then generating the element in the syntax of the DTD. Determining the path that is the best fit entails parsing the path against the DTD. The best fit is expressed in a scoring scale, in which the best score indicates the best fit. Thereafter, the path with the best fit is translated in accordance to the DTD.

Although specific embodiments have been illustrated and described herein, any arrangement which is calculated to achieve the same purpose may be substituted for the specific embodiments shown. This application is intended to cover any adaptations or variations of the present invention. One of ordinary skill in the art will appreciate that the invention can be implemented in an object-oriented design environment, a procedural design environment, or any other design environment that provides the required relationships. In particular, one of skill in the art will readily appreciate that the names of the methods and apparatus are not intended to limit embodiments of the invention. Furthermore, additional methods and apparatus can be added to the components, functions can be rearranged among the components, and new components to correspond to future enhancements and physical devices used in embodiments of the invention can be introduced without departing from the scope of embodiments of the invention. One of skill in the art will readily recognize that embodiments of the invention are applicable to future communication devices, different file systems, and new data types.

The embodiments described above are intended only to illustrate and teach one or more ways of practicing or implementing the present invention, not to restrict its breadth or scope. The actual scope of the invention, which

embraces all ways of practicing or implementing the teachings of the invention,
is defined only by the following claims and their equivalents.

CLAIMS

1. A method comprising:
 - receiving a document and an associated document type definition;
 - generating a mapping file from the document, comprising one or more
5 nodes, each node representative of a possible mapping of an
element of the document type definition to a portion of the
document;
 - generating one or more candidate paths from the mapping file, with each
candidate path representing a possible path from one node in the
10 mapping file to another node in the mapping file;
 - determining a score for each of the one or more candidate paths;
 - selecting one of the candidate paths based on the one or more scores; and
 - converting the one of the candidate paths into a language described by
the document type definition.
- 15 2. The method of claim 1, wherein the document is received after the
document type definition.
3. The method of claim 1, wherein the document type definition comprises
20 a Standard Generalized Markup Language and/or an Extensible Markup
Language document type definition.
4. The method of claim 1, wherein the determining a score for each one or
more candidate paths comprises:
 - 25 determining a score based on compliance with the document type
definition without inferring additional tags for each of the one or
more candidate paths.
5. The method of claim 1, wherein the determining a score for each one or
30 more candidate paths comprises:

determining a score based on the document type definition with inferring tags for each of the one or more candidate paths.

6. The method of claim 1, wherein the determining a score for each one or more candidate paths comprises:
- 5 determining a score based on a recursive examination of each path for a predetermined extent from each node in the tree structure of the mapping file for each of the one or more candidate paths.
- 10 7. The method of claim 1, wherein determining one or more scores comprises determining two or more scores for each one of the one or more candidate paths and defining the highest of the two or more scores as the determined score for the one of the one or more candidate paths.
- 15 8. The method of claim 1, wherein the document comprises a plurality of segments; and
- wherein the actions of generating one or more candidate, determining a score, selecting one of the candidate paths, and converting the one of the candidate paths are performed for each of the plurality of
- 20 segments.
9. A method comprising:
- receiving a document and an associated document type definition;
- generating a mapping file from the document and the document type
- 25 definition, with the mapping file comprising one or more nodes, each node representative of a possible mapping of an element of the document type definition to a portion of the document; and
- disambiguating the mapping file based on the document type definition.
- 30 10. The method of claim 9, wherein the disambiguating comprises:

- generating all of the permutations of the candidate paths from the mapping file, with each candidate path representing a possible path from one node in the mapping file to another node in the mapping file;
- 5 determining a score for each one or more candidate paths; selecting one of the candidate paths based on the one or more scores; and converting the one of the candidate paths into a language described by the document type definition.
- 10 11. A Standard Generalized Markup Language document-type-definition parseable file produced by a process comprising:
- receiving a non-Standard Generalized Markup Language document; receiving a Standard Generalized Markup Language document-type-definition associated with the document;
- 15 disambiguating the document based on the Standard Generalized Markup Language document-type-definition, yielding disambiguated data; and converting the disambiguated data into a file parseable based on Standard Generalized Markup Language.
- 20
12. The Standard Generalized Markup Language document-type-definition parseable file produced by the process of claim 11, wherein receiving a Standard Generalized Markup Language document-type-definition associated with the document comprises receiving a Standard
- 25 Generalized Markup Language document-type-definition in the document.
13. A computer-readable magnetic, electronic, or optical medium comprising computer-executable instructions for:

- causing a computer to read a document and an associated document type definition;
- causing a computer to generate a mapping file based on the document and the document type definition, with the mapping file
- 5 comprising one or more nodes, each node representative of a possible mapping of an element of the document type definition to a portion of the document;
- causing a computer to generate one or more candidate paths from the mapping file, with each candidate path representing a possible
- 10 path from one node in the mapping file to another node in the mapping file;
- causing a computer to determine one or more scores from the one or more candidate paths;
- causing a computer to select one of the candidate paths based on the one
- 15 or more scores; and
- causing a computer to convert the one of the candidate paths into a language described by the document type definition.

14. A system comprising:
- 20 means for receiving a document and an associated document type definition;
- means for generating a mapping file based on the document and the document type definition, with the mapping file comprising one or more nodes, each node representative of a possible mapping of
- 25 an element of the document type definition to a portion of the document;
- means for determining one or more scores for one or more candidate paths, with each candidate path representing a possible path from one node in the mapping file to another node in the mapping file;
- 30 and

means for selecting one of the candidate paths based on the one or more scores.

15. The system of claim 13, wherein the means for receiving, the means for
5 generating, the means for determining, and the means for selecting exist as
respective software modules in a memory coupled to one or more computer
processors or within various parts of a mainframe computer or within a SUN
Ultra 4000 Server or within an IBM-compatible personal computer.

10 16. A system for transacting in electronic commerce comprising:
a processor;
a storage device coupled to the processor;
software means operative on the processor for disambiguating
ambiguated data based on a document type definition.

15

17. The system of claim 16, wherein the software means comprises:
software means for generating all of the permutations of the candidate
paths from a mapping file of the ambiguated data, with each
candidate path representing a possible path from one node in the
20 mapping file to another node in the mapping file.

20

18. A computerized system comprising:
a document of ambiguous data;
a document type definition;
25 a mapper of ambiguous data, operatively coupled to the document and
operatively coupled to the document, yielding a mapping file
from the document and the document type definition;
a disambiguator operatively coupled to the mapping file and the
document type definition, yielding an output file; and
30 wherein the document type definition describes a markup syntax; and

30

wherein the output file complies with the syntax described by the document type definition.

19. The computerized system of claim 18, the system comprising:
5 a configuration file operatively coupled to the disambiguator which specifies predetermined settings and/or parameters of the disambiguator.
20. The computerized system of claim 18, the system comprising:
10 an activity log operatively coupled to the disambiguator that receives and record information that describes the activity of the conversion process of the disambiguator.
21. The computerized system of claim 18, the disambiguator comprising:
15 a permutater of one or more candidate paths from the mapping file, operatively coupled to the mapping file, with each candidate path representing a possible path from one node in the mapping file to another node in the mapping file;
a scorer of the one or more candidate paths, operatively coupled to the
20 permutater, yielding a corresponding number of one or more scores;
a selector of one or more candidate paths, based on the one or more scores, operatively coupled to the scorer, yielding a selected candidate path; and
25 a converter of the selected candidate path into a language described by the document type definition, operatively coupled to the selector of one or more candidate paths and operatively coupled to the document type definition.
- 30 22. The computerized system of claim 21, the disambiguator comprising:

- a selector of segments, operatively coupled to the mapping file and
operatively coupled to the permutator, that receives the mapping
file and transmits a segment of the nodes of the mapping file to
the permutator;
- 5 a comparator operatively coupled to the mapping file and the permutator
that determines the extent of remaining segments in the mapping
file.

23. The computerized system of claim 21, the scorer comprising:
10 a tie-breaker operatively coupled to the permutator that selects one of a plurality
of candidate paths have equal scores.

24. A computer-readable magnetic, electronic, or optical medium
comprising:
15 a converter; and
a plurality of document type definitions associated with the converter.

25. A computer-readable magnetic, electronic, or optical medium
comprising:
20 a document;
a document type definition associated with the document; and
a converter operably coupled to the document and the document type
definition that converts the document into an output file that
complies with the document type definition.

25
26. A data structure stored on a computer-readable medium for representing
a possible mapping of an element of a document type definition to a portion of a
document comprising:
one or more segments.

30

27. The data structure of claim 26, wherein each of the one or more segments comprises:

- a field storing data representing a solid node;
- a field storing data representing a quantum node; and
- 5 a field storing data representing a terminal node.

28. The data structure of claim 27, wherein the data structure comprises two or more segments, and wherein two contiguous segments further comprising, a first segment and a second segment, are joined whereby the field storing data
10 representing a terminal node of the first segment further comprises the field storing data representing a solid node of the second segment.

29. A computer data signal embodied in a carrier wave and representing a sequence of instructions which, when executed by a processor, cause the
15 processor to perform:

- receiving a non-Standard Generalized Markup Language document;
- receiving a Standard Generalized Markup Language document-type-
definition associated with the document;
- disambiguating the document based on the Standard Generalized Markup
20 Language document-type-definition, yielding disambiguated data;
- and
- converting the disambiguated data into a file parseable based on Standard
Generalized Markup Language.

25 30. A computer data signal embodied in a digital data stream comprising data comprising:

- a representation of a solid node;
- a representation of a quantum node; and
- a representation of a terminal node;

30 wherein the computer data signal is generated by a method comprising:

generating a mapping file from the document and the document type definition, with the mapping file comprising one or more nodes, each node representative of a possible mapping of an element of the document type definition to a portion of the document.

5

31. A computer data signal embodied in a digital data stream comprising data comprising:

a representation of a Standard Generalized Markup Language document-type-definition parseable file;

10

wherein the computer data signal is generated by a method comprising:

generating one or more candidate paths from a mapping file of an ambiguated document and a document type definition, with each candidate path representing a possible path from one node in the mapping file to another node in the mapping file;

15

determining a score for each of the one or more candidate paths;

selecting one of the candidate paths based on the one or more scores; and

converting the one of the candidate paths into Standard Generalized Markup Language document-type-definition parseable file described by the document type definition.

20

32. A method comprising:

providing a disambiguator;

disambiguating a first document based on a first DTD using the disambiguator;

25

disambiguating a second document based on a second DTD using the disambiguator, with the second DTD being different than the first DTD.

33. A method of disambiguating electronic documents, comprising:

30

providing a set of two or more DTDs;

receiving a first document for disambiguation; and
selecting at least one of the set of DTDs; and
disambiguating the first document based on the selected one of the set of
DTDs.

5

34. A method of disambiguating electronic documents, comprising:
receiving a first document for disambiguation, the document having first
and second portions, each portion being ambiguated;
disambiguating the first portion of the document and not the second
portion of the document; and
outputting a second document comprising the disambiguated first portion
of the document and second portion of the first document.

10

35. A method comprising selectively converting to one of a plurality of
markup languages.

15

20

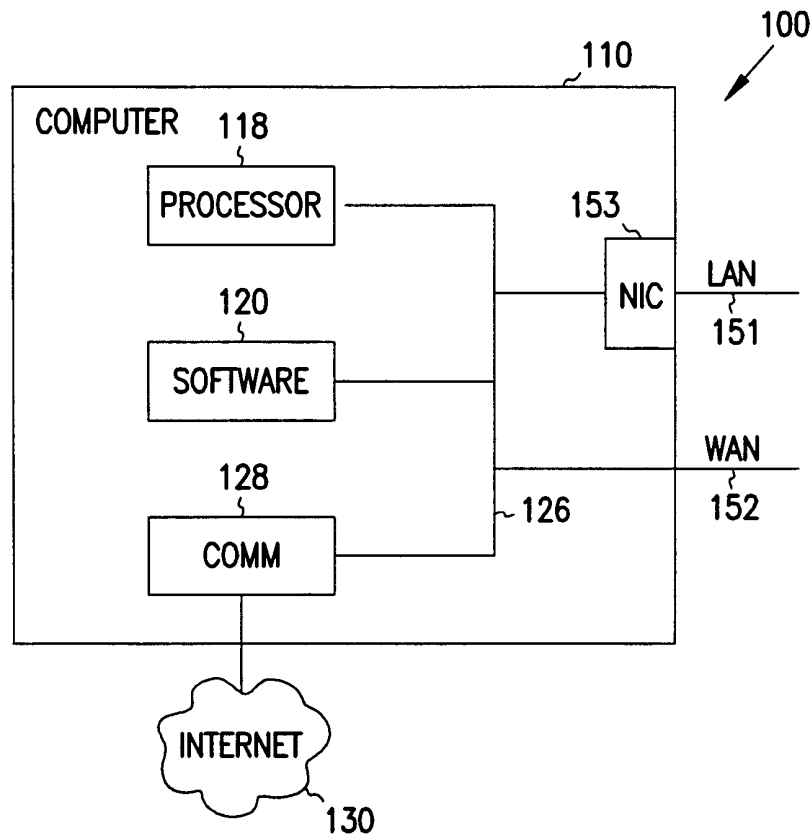

FIG. 1

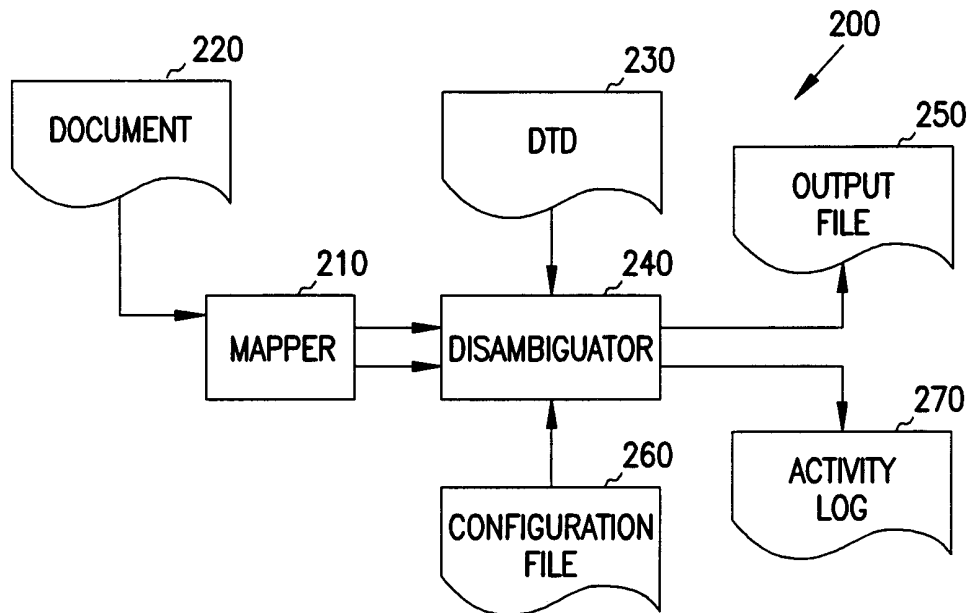

FIG. 2

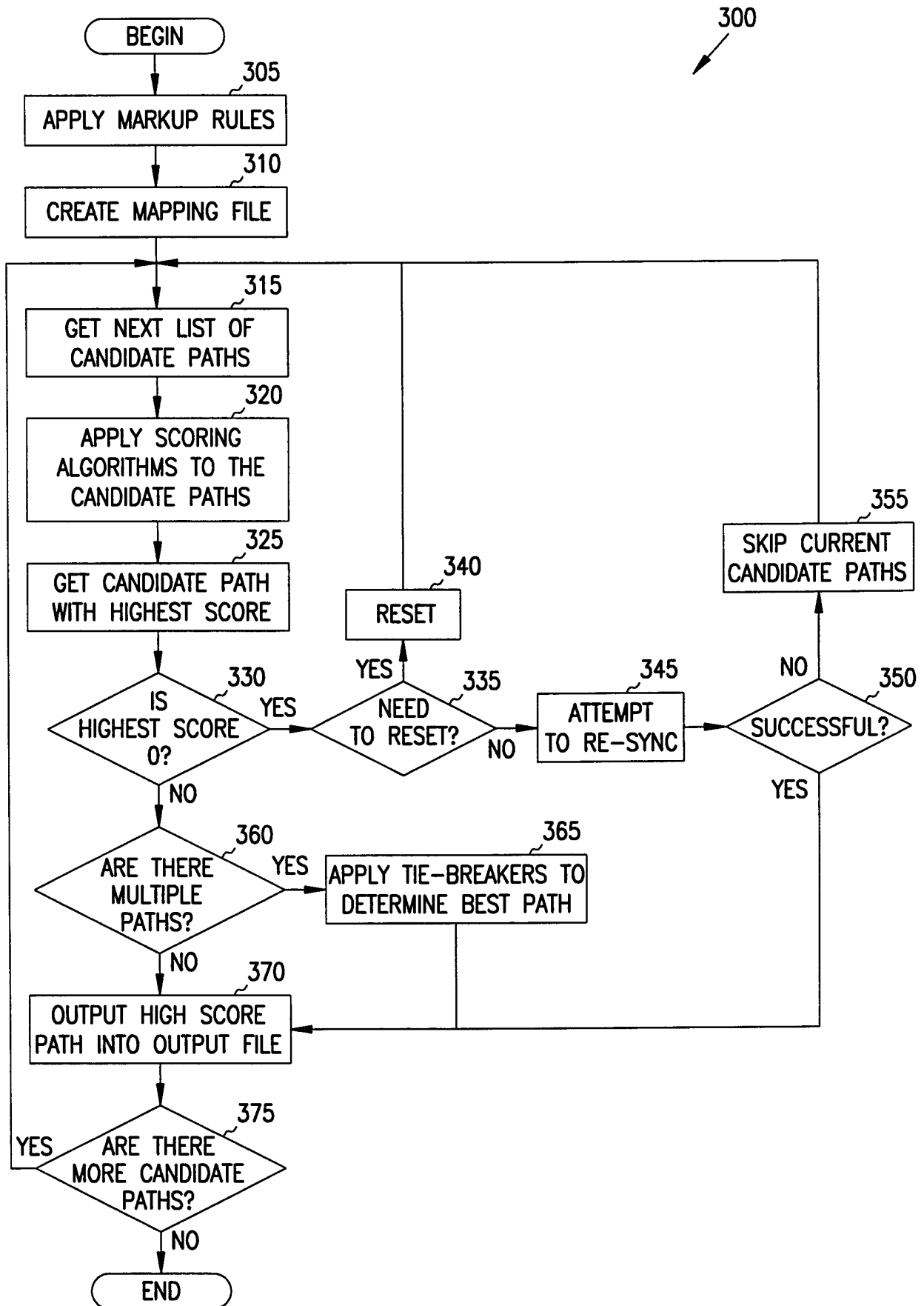

FIG. 3

PAGE MISSING AT THE TIME OF PUBLICATION

4/6

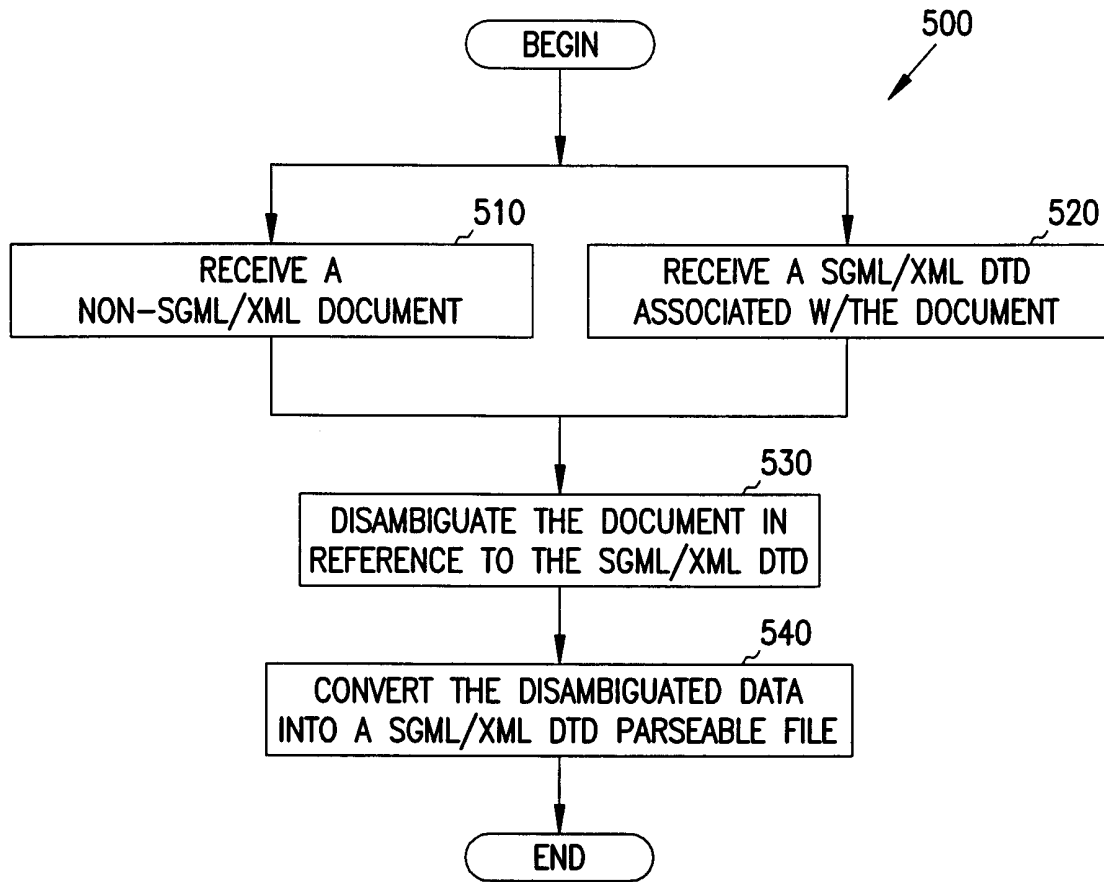

FIG. 5

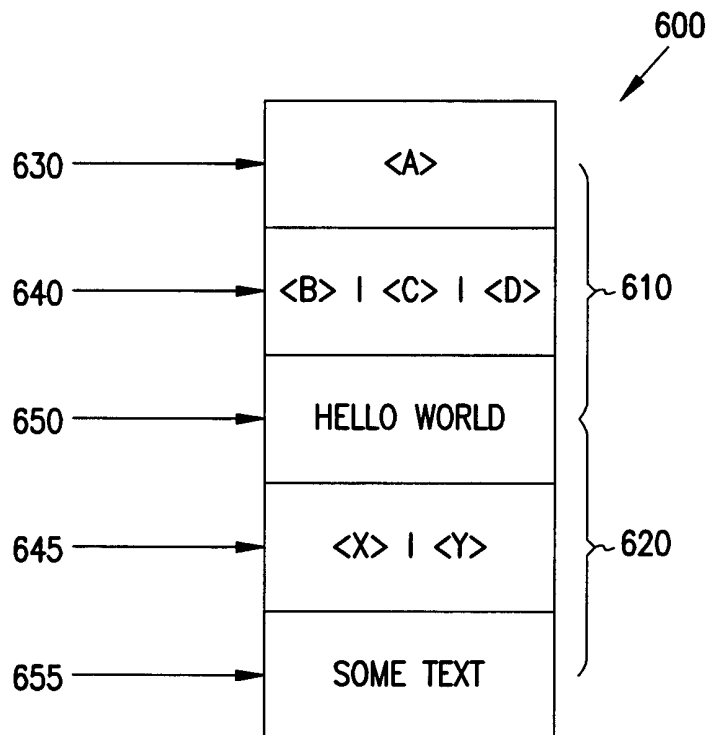

FIG. 6

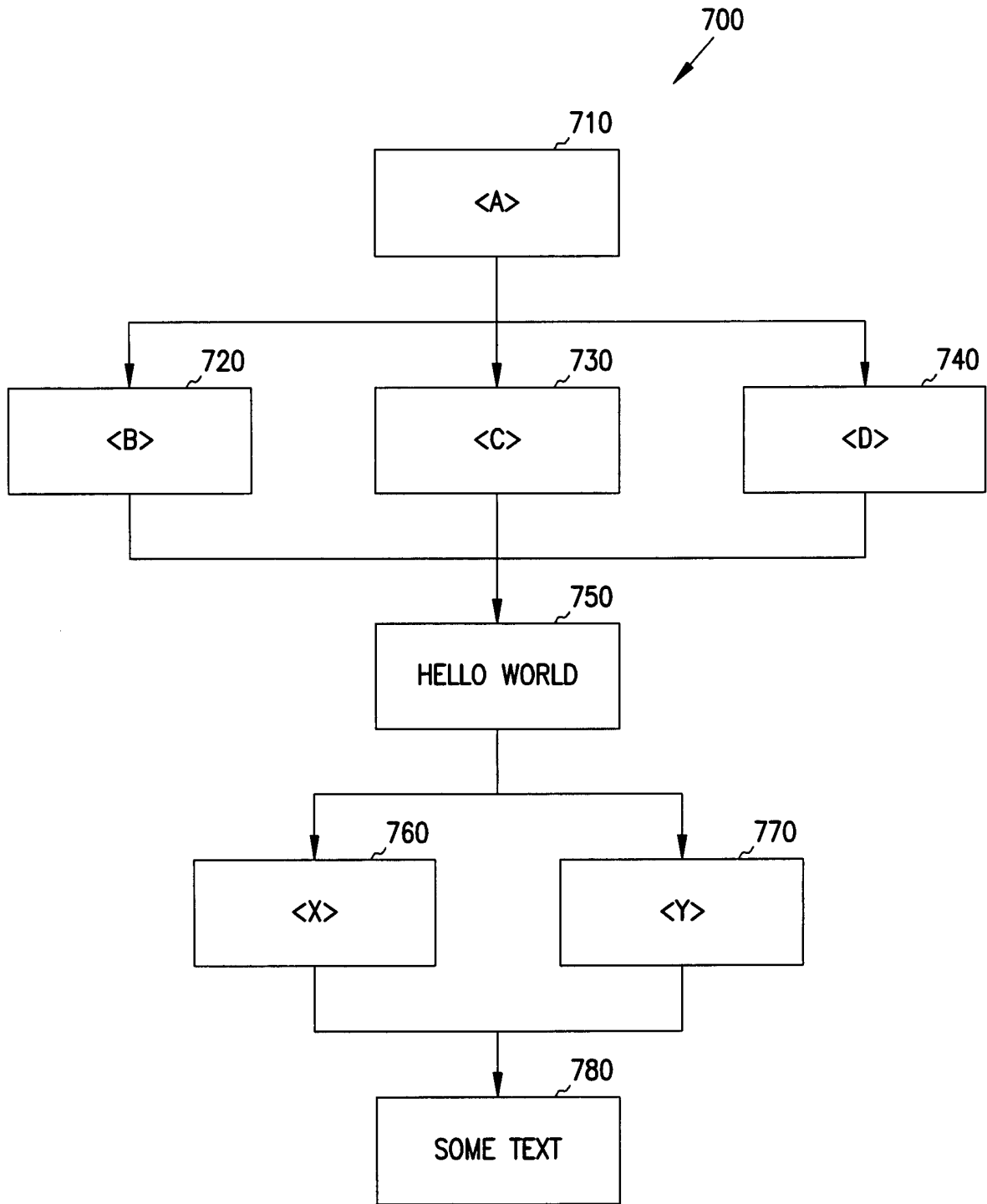

FIG. 7

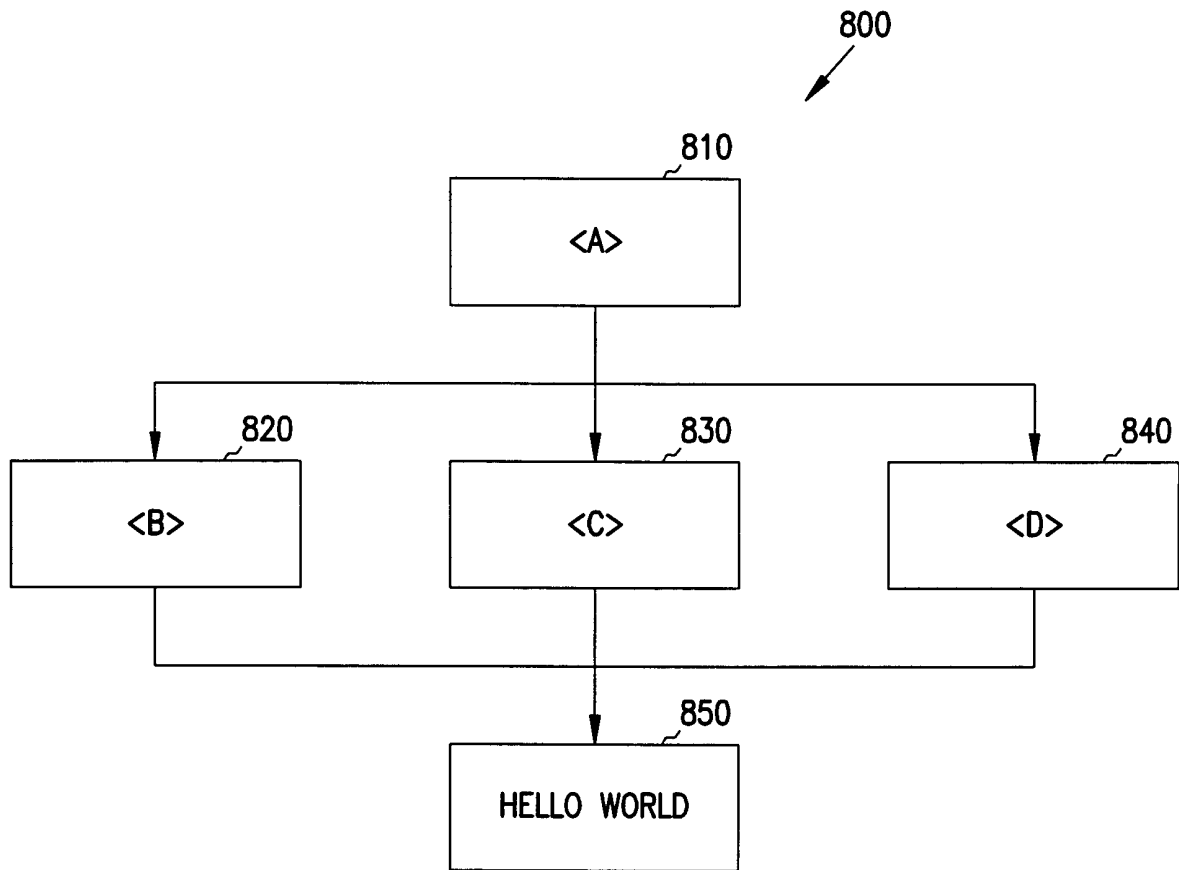

FIG. 8

INTERNATIONAL SEARCH REPORT

International application No.
PCT/US00/16482

A. CLASSIFICATION OF SUBJECT MATTER		
IPC(7) :G06F 7/50, 15/00, 17/00, 17/21, 17/28 US CL :704/5; 707/532; 708/705 According to International Patent Classification (IPC) or to both national classification and IPC		
B. FIELDS SEARCHED		
Minimum documentation searched (classification system followed by classification symbols) U.S. : 704/5; 707/532; 708/705		
Documentation searched other than minimum documentation to the extent that such documents are included in the fields searched		
Electronic data base consulted during the international search (name of data base and, where practicable, search terms used) IEEE search terms: DTD, document, conversion, SGML		
C. DOCUMENTS CONSIDERED TO BE RELEVANT		
Category*	Citation of document, with indication, where appropriate, of the relevant passages	Relevant to claim No.
X --- Y	US 5,848,386 A (MOTOYAMA) 08 December 1998, col.2, lines 43-63.	16, 17, 24-26, 32-35 ----- 1-15, 18-23, 27-31
Y	US 5,629,846 A (CRAPO) 13 May 1997, whole document.	1-15, 18-23, 29, 31
Y	US 5,583,762 A (SHAFER) 10 December 1996, whole document.	27, 28, 30
<input checked="" type="checkbox"/> Further documents are listed in the continuation of Box C. <input type="checkbox"/> See patent family annex.		
* "A" "E" "L" "O" "P"	Special categories of cited documents: document defining the general state of the art which is not considered to be of particular relevance earlier document published on or after the international filing date document which may throw doubts on priority claim(s) or which is cited to establish the publication date of another citation or other special reason (as specified) document referring to an oral disclosure, use, exhibition or other means document published prior to the international filing date but later than the priority date claimed	"T" "X" "Y" "&" later document published after the international filing date or priority date and not in conflict with the application but cited to understand the principle or theory underlying the invention document of particular relevance, the claimed invention cannot be considered novel or cannot be considered to involve an inventive step when the document is taken alone document of particular relevance, the claimed invention cannot be considered to involve an inventive step when the document is combined with one or more other such documents, such combination being obvious to a person skilled in the art document member of the same patent family
Date of the actual completion of the international search 23 AUGUST 2000		Date of mailing of the international search report 19 SEP 2000
Name and mailing address of the ISA/US Commissioner of Patents and Trademarks Box PCT Washington, D.C. 20231 Facsimile No. (703) 305-3230		Authorized officer MICHAEL RAZAVI <i>Rugenia Zogian</i> Telephone No. (703) 305-3900

INTERNATIONAL SEARCH REPORT

International application No.
PCT/US00/16482

C (Continuation). DOCUMENTS CONSIDERED TO BE RELEVANT

Category*	Citation of document, with indication, where appropriate, of the relevant passages	Relevant to claim No.
A	HUNTER, B. Conversion of documents to and from SGML IEEE Colloquium on Adding Value to Documents with Markup Languages 1994, pages 5/1 - 5/4.	1-35