

No. 681,445

Patented Aug. 27, 1901.

T. C. DEXTER.

DEVICE FOR CONTROLLING THE ACTION OF PRINTING PRESSES.

(Application filed July 9, 1900.)

(No Model.)

7 Sheets—Sheet 1.

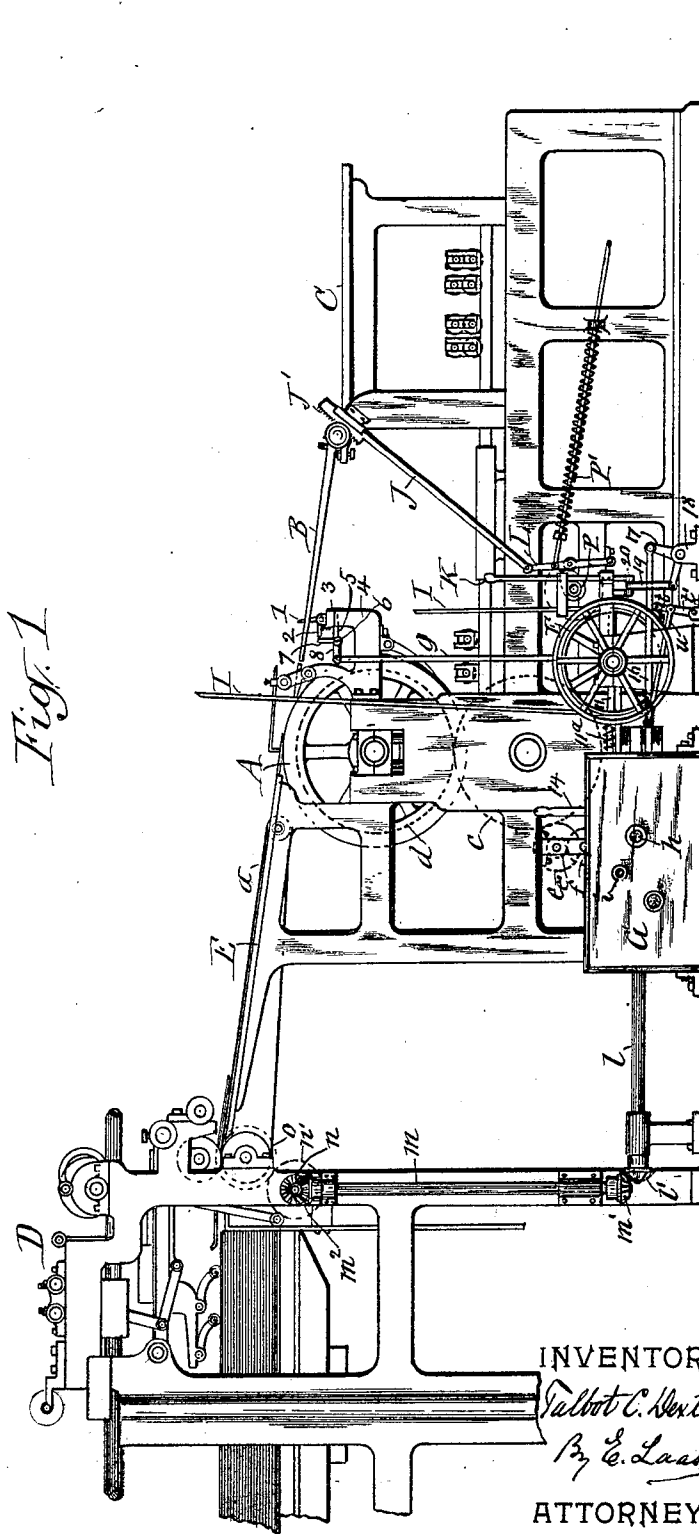

Fig. 1

WITNESSES:

H. S. Smith

J. J. Laess

INVENTOR

Talbot C. Dexter

By E. Laess

ATTORNEY

No. 681,445.

Patented Aug. 27, 1901.

T. C. DEXTER.

DEVICE FOR CONTROLLING THE ACTION OF PRINTING PRESSES.

(Application filed July 9, 1900.)

(No Model.)

7 Sheets—Sheet 2.

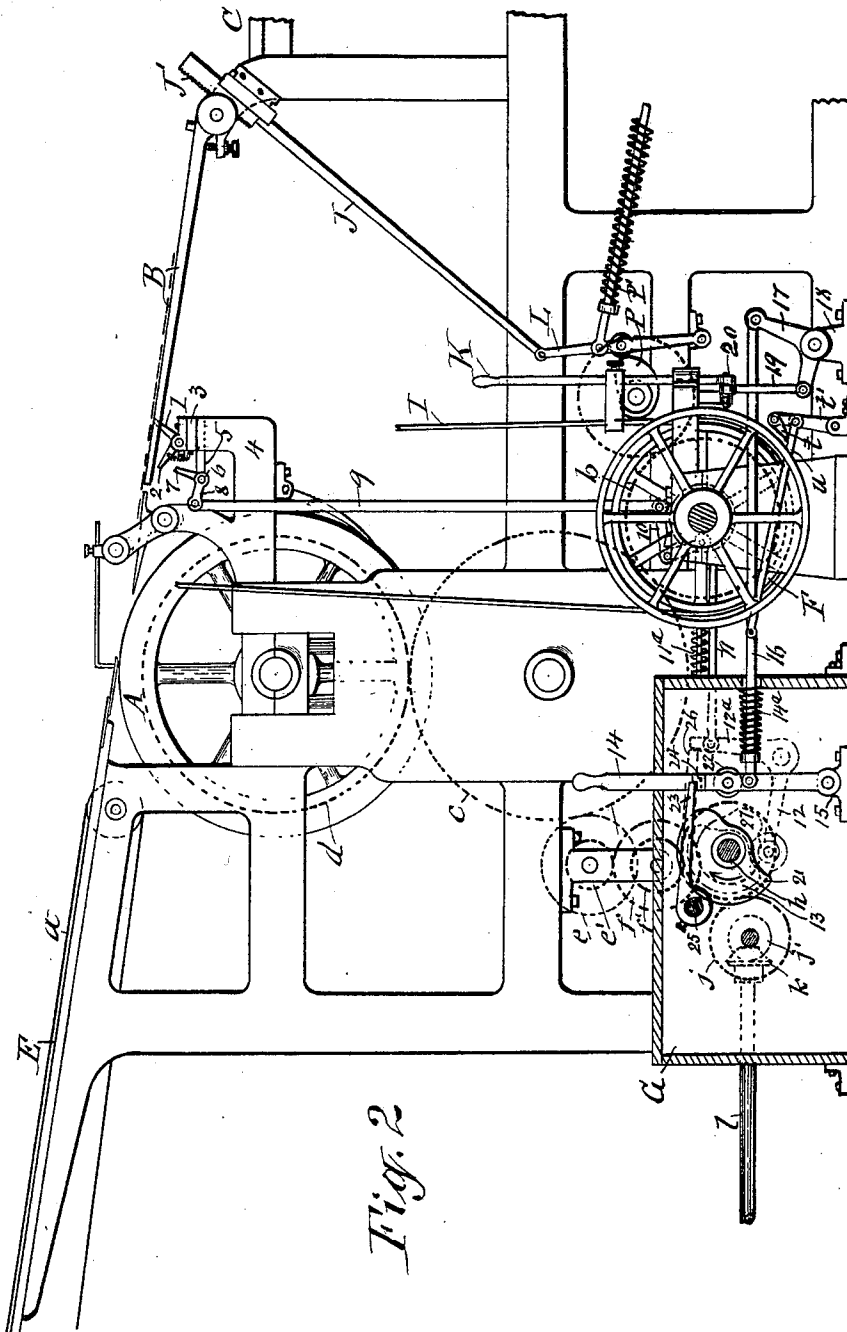

Fig. 2

WITNESSES:
H. B. Smith,
J. J. Laass

INVENTOR
Talbot C. Dexter
By E. Laass
ATTORNEY

No. 681,445.

Patented Aug. 27, 1901.

T. C. DEXTER.

DEVICE FOR CONTROLLING THE ACTION OF PRINTING PRESSES.

(Application filed July 9, 1900.)

(No Model.)

7 Sheets—Sheet 3.

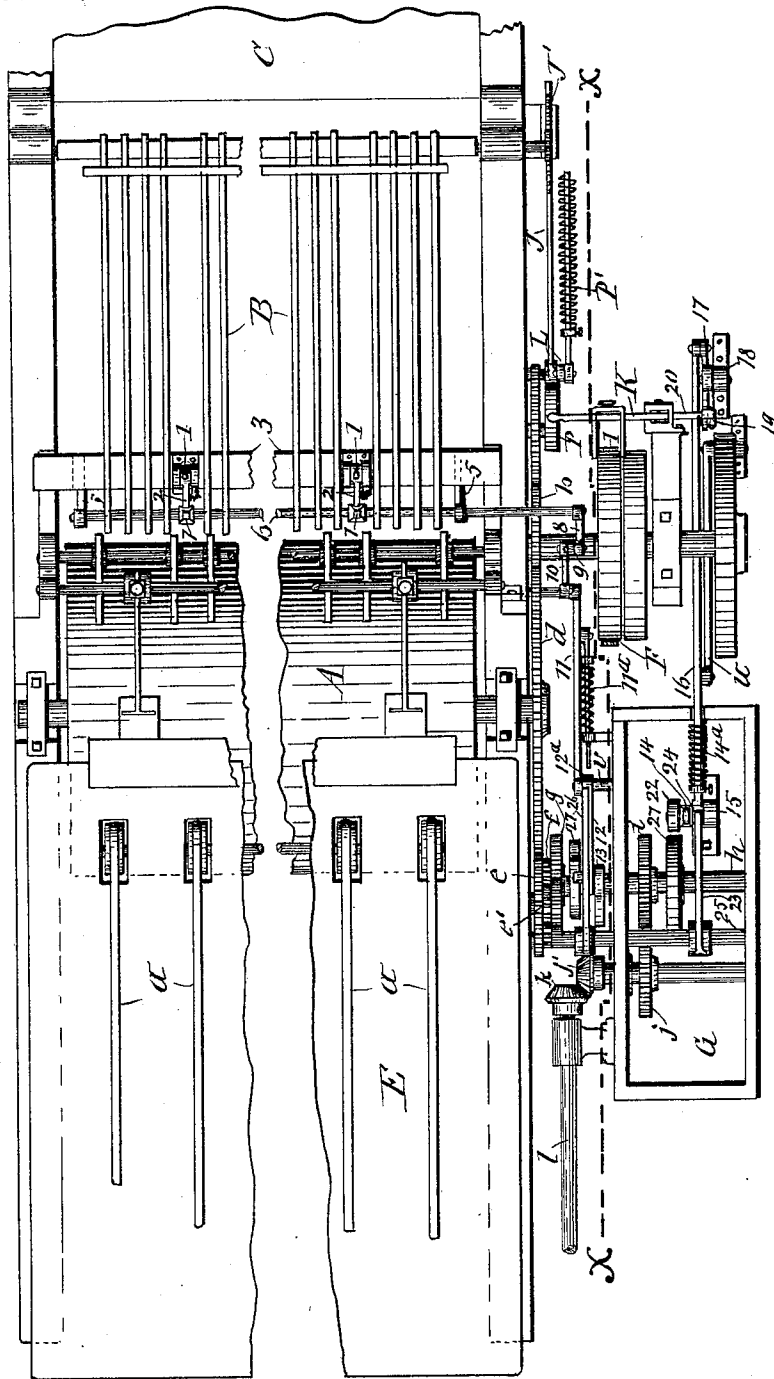

Fig. 3

WITNESSES:

H. B. Smith.

J. J. Laess

INVENTOR

Talbot C. Dexter

By E. Laess

ATTORNEY

No. 681,445.

Patented Aug. 27, 1901.

T. C. DEXTER.

DEVICE FOR CONTROLLING THE ACTION OF PRINTING PRESSES.

(Application filed July 9, 1900.)

(No Model.)

7 Sheets—Sheet 5.

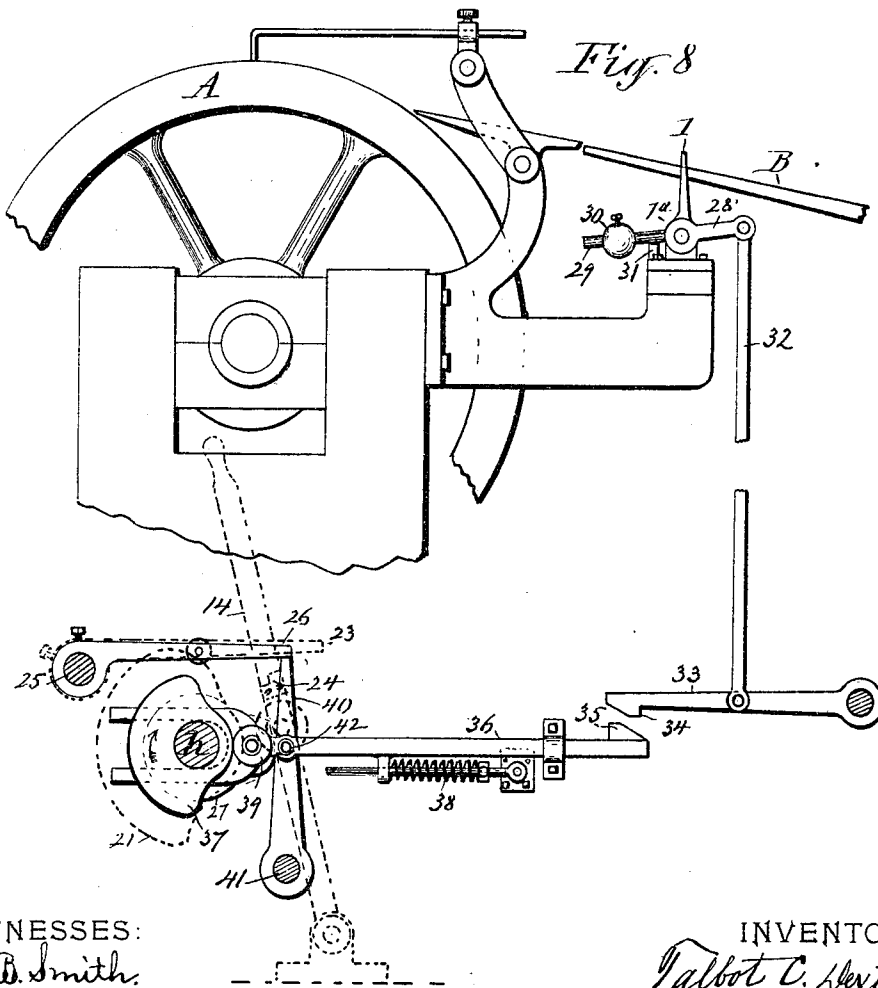
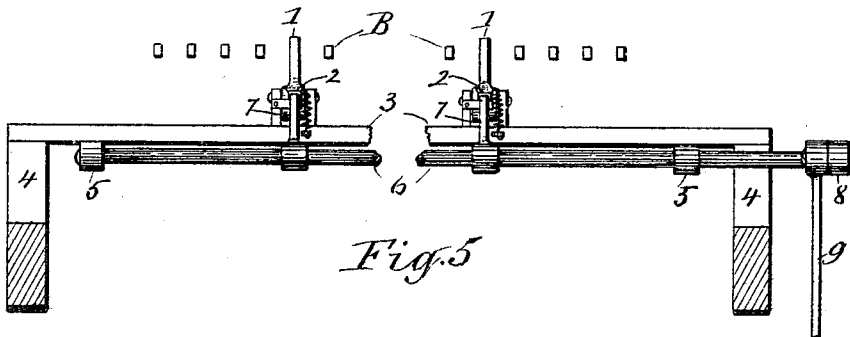

WITNESSES:
H. B. Smith.
J. J. Luce.

INVENTOR
Talbot C. Dexter
By E. Luce
ATTORNEY

T. C. DEXTER.

DEVICE FOR CONTROLLING THE ACTION OF PRINTING PRESSES.

(Application filed July 9, 1900.)

(No Model.)

7 Sheets—Sheet 7.

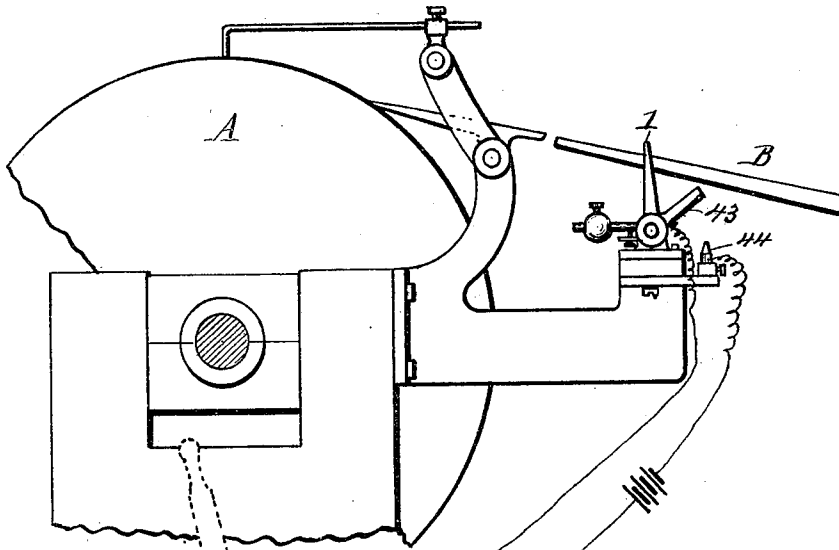

Fig. 9

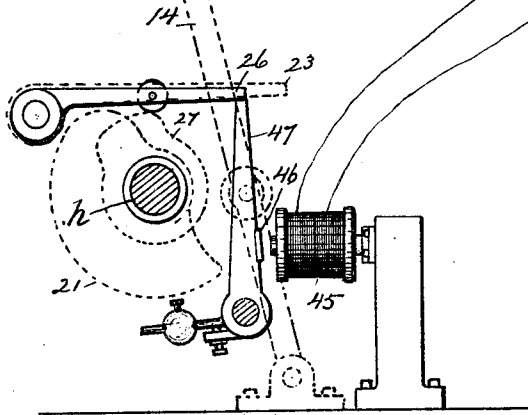

Fig. 10

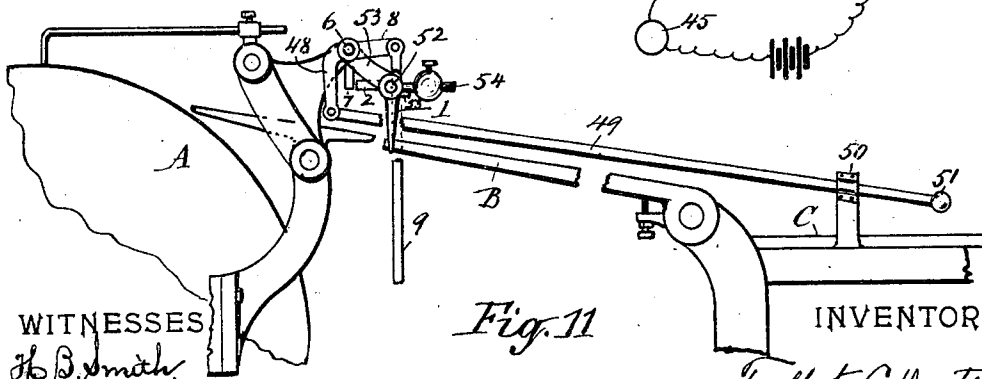
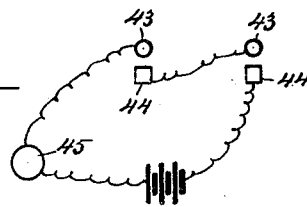

Fig. 11

WITNESSES

H. B. Smith

J. J. Lasse

INVENTOR

Talbot C. Dexter

By E. Lasse

ATTORNEY

UNITED STATES PATENT OFFICE.

TALBOT C. DEXTER, OF PEARL RIVER, NEW YORK.

DEVICE FOR CONTROLLING THE ACTION OF PRINTING-PRESSES.

SPECIFICATION forming part of Letters Patent No. 681,445, dated August 27, 1901.

Application filed July 9, 1900. Serial No. 22,957. (No model.)

To all whom it may concern:

Be it known that I, TALBOT C. DEXTER, a citizen of the United States, and a resident of Pearl River, in the county of Rockland, in the State of New York, have invented new and useful Improvements in Devices for Controlling the Action of Printing-Presses, of which the following, taken in connection with the accompanying drawings, is a full, clear, and exact description.

This invention relates to the class of printing-presses which are provided with a fly in front of the impression-cylinder to carry the printed paper away from said cylinder; and the invention is specially designed for printing-presses of the aforesaid class equipped with a paper-feeding machine supplying the paper automatically to the impression-cylinder. In the operation of such printing-presses some difficulty has been experienced in the delivery of the paper from the impression-cylinder onto the fly, owing to the liability of the front edge of the sheet in transit encountering the ends of the fly-fingers or the ends of other fingers usually arranged to pick the front edge of the sheet from the impression-cylinder. Such accidental encounter arrests the sheet in its passage from the impression-cylinder and causes the press to become clogged by the continuation of the automatic supply of paper to the press, and such clogging results in serious damage to the delicate faces of the plates comprising the forms on the press-bed.

The object of this invention is to obviate the aforesaid injurious results, and to that end the invention consists, essentially, in the combination, with a printing-press, automatic paper-feeder, mechanisms actuating said press and feeder in common, and delivering means disposed to receive the paper from the impression-cylinder, of stop mechanism organized to automatically arrest the aforesaid actuating mechanisms, detectors normally in the path of the paper to the aforesaid delivering means, and mechanism restraining the stop mechanism and controlled by the detectors; and the invention also consists in novel features of the details of construction and the combination of its component parts, as hereinafter described, and set forth in the claims.

The invention is fully illustrated in the annexed drawings, in which—

Figure 1 is a side elevation of a printing-press equipped with a paper-feeding machine and with my invention for controlling the action of said machine. Fig. 2 is an enlarged side view of said printing-press with a vertical longitudinal section of the case which incloses portions of the tripping or stop mechanism. Fig. 3 is a plan view of Fig. 2. Fig. 4 is a side elevation in a plane along the line X X in Fig. 3. Fig. 5 is an enlarged transverse section on line Y Y in Fig. 4 viewed in the direction of the dart. Figs. 6 and 7 are enlarged detail views illustrating more clearly the operation of my invention, and Figs. 8, 9, 10, and 11 illustrate modifications of my invention.

Similar characters of reference indicate corresponding parts.

A represents the impression-cylinder of a printing-press, which may be of the type designated "two-revolution" press or any other analogous form in which the printed paper is delivered from the front of the impression-cylinder onto a fly B, which carries the paper to the usual fly-board C. The fly is operated by a pitman J, which has affixed to one of its ends a rack J', engaging a pinion on the shaft of the fly. The opposite end of said pitman is connected to a lever L, which receives oscillatory motion from a rotary cam P, with which it is held in contact by means of a spring-actuated rod P', as shown in Figs. 2 and 4 of the drawings.

D denotes a paper-feeding machine, which may also be one of any suitable and well-known construction to automatically supply the paper to the impression-cylinder, to which it is conducted by the feed-board E and paper-conveying tapes a, traveling lengthwise of said feed-board.

F represents the main driving-pulley, to the shaft of which is fastened a gear-wheel b, which meshes with a gear-wheel c, mounted on a shaft which is journaled in bearings on the press-frame. The wheel c engages a gear-wheel d, fastened to the shaft of the impression-cylinder A, which thus receives its rotary motion.

The feeding-machine D is caused to operate in unison with the impression-cylinder by a

suitable train of gears, which in this instance is represented to consist of a gear *e*, meshing with the gear *c* and having fastened to its side a pinion *e'*, engaging a gear *f*, which has also a pinion *f'* fastened to its side. This latter pinion engages a gear *g*, mounted on a shaft *h*, which is supported in bearings secured to the sides of a box or case G, disposed near the side of the press-frame and securely fastened in its position. To the shaft *h* is fastened a second gear *i*, which engages a gear *j*, mounted on a shaft journaled in the sides of the box G. A miter-pinion *j'* on this shaft engages a corresponding pinion *k*, fastened to a shaft *l*, which is extended to the feeding-machine D, as shown in Fig. 1 of the drawings. In suitable bearings on the frame of said machine is journaled a shaft *m*, which has on one of its ends a miter-gear *m'*, meshing with a similar gear *l'* on the shaft *l*. Another miter-gear *m²* on the opposite end of the shaft *m* meshes with a corresponding gear *n*, secured to a shaft which extends across the frame of the feeding-machine. To this shaft is also fastened a gear *n'*, meshing with a gear *n²*, mounted on the shaft of the feed-roller *o* of the feeding-machine.

The described mechanism for actuating the printing-press and feeding-machine in common is only one of many differently-arranged mechanisms adapted for the same purpose, and I therefore do not limit myself to any specific construction and arrangement of said mechanism.

I represents the driving-belt, and K the belt-shifting lever.

The purpose of my present invention is to automatically actuate the belt-shifting lever K so as to throw the belt from the driving-pulley F onto the loose pulley and at the same time applying the brake *t*, and thus instantly stop the motion of the printing-press and paper supplying or feeding machine in case the delivery of the printed paper from the impression-cylinder onto the fly B becomes clogged, as hereinbefore described. To effect this automatic stopping of the actuating mechanisms of the press and feeding-machine, I employ mechanical detectors or suitable means arranged to be actuated by the paper in transit from the impression-cylinder to the fly and controlling the aforesaid actuating mechanisms. The most essential feature of the invention resides in the arrangement of said detectors 1, which are normally in the path of the paper to the fly. The means for utilizing these detectors for accomplishing the automatic stopping of the actuating mechanism of the press and feeding-machine are susceptible of modifications, as illustrated in the annexed drawings, in which Figs. 1 to 7, inclusive, show my preferred construction. The aforesaid detectors I prefer to form of bell-cranks pivoted to brackets mounted on a stationary bar 3, which is arranged at right angles to the fly-fingers and parallel to the plane thereof and supported at opposite ends on brackets 4, fas-

tened to the press-frame. Said bell-cranks are disposed between the fly-fingers and oscillate in planes parallel with said fingers. One of the limbs of each of said bell-cranks constitutes one of the detecting-fingers 1 and is sustained with its free end normally in the path of the paper to the fly, as represented in Figs. 1 and 6 of the drawings. The limb of the bell-crank projects from the heel of the detecting-finger 1 toward one end of the fly. Inasmuch as it is quite common that the sheet is cut in two in the center while passing through the press, it is necessary to employ two detectors 1 1 at opposite sides of the center of the path of the paper to the fly, and each of said detectors is to operate independently of the other.

Parallel with the bar 3 is a rock-shaft 6, mounted at its ends on suitable supports 5, secured to the brackets 4. To this rock-shaft are fastened arms 7 7, which are positioned to encounter the free ends of the limbs 2, and thereby limit the motion of the rock-shaft, which derives its motion from the following mechanism, to wit: On a stud *v*, projecting, either from the case G or from the press-frame, is pivoted a bell-crank lever 12, which receives intermittent oscillatory motion by means of a spring 11^a, forcing said lever in one direction and causing it to bear on a cam 13, mounted on the rotary shaft *h* which cam forces the lever in the opposite direction. The arm 12^a of said lever is connected by a rod 11 to one of the arms of a bell-crank 10, pivoted to a suitable support on the press-frame. The other arm of the bell-crank 10 is connected by a pitman 9 to an arm 8, fastened to the end of the rock-shaft 6. The action of this rock-shaft is timed with the operation of the printing-press to throw the arms 7 of said shaft toward the limbs 2 of the detecting-fingers 1 at the time the printed sheet is due to pass across the said detecting-fingers. This timing of said mechanism is essential for the purpose hereinafter explained.

14 denotes a lever which is preferably pivoted to a block 15, fastened to the bottom of the interior of the case G. This lever is connected by a rod 16 to one of the arms of a bell-crank 17, pivoted to a suitable stationary support 18 near the driving-pulley F. The other arm of the bell-crank 17 is connected by a rod 19 to an arm 20, which projects at right angles from the belt-shifting lever K, at or near the pivot thereof. The described connection allows the lever 14 to actuate the lever K so as to throw the belt I from the driving-pulley F onto the loose pulleys.

A brake-shoe *t* is attached to a lever *t'*, which is connected by a rod *u* to the rod 16, and thus said brake is applied to the usual balance-wheel of the press simultaneously with the shifting of the belt onto the loose pulley.

The action of the lever 14 is controlled by a cam 21, secured to the rotary shaft *h*, which cam is shaped to press at predetermined intervals of time against a roller 22, pivoted to

the lever 14, and by said pressure said lever is forced to a position which causes the lever K to maintain the belt I on the driving-pulley, as represented in Fig. 7 of the drawings.

5 A rock-arm 23 periodically engages a shoulder 24 on the lever 14, and thereby retains said lever in the aforesaid position during the period of the release of said lever from the pressure of the cam 21, as shown in Fig. 2 of the drawings. The rock-arm 23 is attached to a shaft 25, which is journaled in suitable bearings in the sides of the case G and receives rocking motion by means of another arm 26, fastened to said shaft and extending across the top of a cam 27, attached to the rotary shaft *h*, which cam intermittently lifts said arm. This arm is extended toward the upwardly-extending arm 12^a of the bell-crank lever 12 sufficiently to cause the descending free end of the arm 26 to encounter the top of the arm 12^a of the bell-crank lever 12 when the latter is swung toward the arm 26 by the action of the cam 13, as shown in Figs. 4 and 6 of the drawings. This encounter prevents the other arm 23 from dropping to a position to engage the shoulder 24 on the lever 14, which is thereby allowed to be swung by force of the spring 14^a to a position which causes the lever K to shift the belt from the driving-pulley F onto the loose pulley, and thus stop the actuating mechanisms of the press and its paper-feeding machine. The aforesaid movement of the bell-crank lever 12 toward the arm 26 and the consequent stopping of the actuating mechanism, as last described, is controlled by the detectors 1 1, which are sustained normally in the path of the paper to the fly B, as shown in Figs. 1 and 6 of the drawings, and when in said position the limbs 2 2 of said detectors are opposed to the movement of the arms 7 7 of the rock-shaft 6. The encountering of said arms with the ends of the limbs 2 2 locks the rock-shaft and confines the bell-crank lever 12 in the position to which it is moved by the cam 13, as more clearly shown in Fig. 6 of the drawings, said position arresting the descent of the arm 26, and thus causing the arm 23 to release the lever 14, which by its connection with the belt-shifting lever throws the belt onto the loose pulley. The press and feeding-machine are set in motion by the person in charge operating the belt-shifting lever K to throw the belt onto the driving-pulley in the usual manner. The printed paper passing from the impression-cylinder onto the top of the fly comes in contact with the projecting ends of the detectors 1 1 and tilts said detectors, as shown in Fig. 7 of the drawings. This holds the limbs 2 of the detectors in position to allow free action of the arms 7 of the rock-shaft 6, and thus permits the driving-belt to remain on the driving-pulley. In case the printed paper becomes accidentally arrested in its transit from the impression-cylinder to the fly and is thus prevented from passing onto the top of the fly the detectors 1 1 remain in

their normal position, as shown in Figs. 1 and 6 of the drawings, and consequently the actuating mechanism of the press and feeding-machine is instantly stopped in the manner hereinbefore described. This automatic stopping of the press and feeding-machine effectually guards against clogging of the press, and thus obviates the injurious effects resulting from said clogging.

If desired, an additional lever similar to the lever 14 and operated and controlled in substantially the same manner may be employed for automatically tripping the impression-cylinder of a two-revolution press, as illustrated in my prior application for Letters Patent, Serial No. 9,201, filed March 19, 1900.

Although the hereinbefore-described devices for automatically controlling the actuating mechanisms of the press are capable of effectually performing their ascribed functions, yet I wish it to be understood that I do not limit myself to the use of the same, inasmuch as other means may be resorted to for accomplishing the desired result, as illustrated in Figs. 8, 9, and 11 of the accompanying drawings.

Referring to Fig. 8, the detector 1 in this case is fastened to a shaft 1^a, which has also attached to its end two arms 28 and 29, extending in opposite directions from the shaft. The arm 29 has adjustably mounted on it a weight 30, which causes said arm to normally rest upon a stop 31 and the detector 1 to project with its free end above the plane of the fly when in position to receive the printed paper from the impression-cylinder. The other arm 28 is connected by a rod 32 to a dog 33, which is provided with a hook 34, facing a similar hook 35, formed on the end of a rod 36, which receives intermittent reciprocating motion by means of a cam 37, attached to the rotary shaft *h*, and by the assistance of a spring 38, pushing the rod 36 toward said cam and maintaining in contact therewith a roller 39, pivoted to the rod. To the shaft *h* are also attached the cams 21 and 27, which actuate, respectively, the lever 14 and arm 26 substantially in the same manner as hereinbefore described. In the present instance the action of the arm 26 is controlled by a prop 40, which is pivoted at its lower end, as shown at 41, to the case G or to other suitable support. The free end portion of said arm is pivotally connected to the rod 36, as shown at 42, and thus partakes motion from said rod. The operation of this modification of my invention is as follows: When the paper passes properly from the impression-cylinder to the fly B, said paper tilts the detector from the passage of the paper and turns the shaft 1^a sufficiently to cause the arm 28 to lower the free end of the dog 33, so as to catch by its hook 34 onto the hook 35 of the rod 36 when pushed toward the dog by the cam 37. By this movement of the rod 36 the prop 40 is swung into a position which allows the arm 26 to freely follow the move-

ment of its actuating-cam, and in descending it carries down with it the arm 23 to a position to engage the shoulder 24 on the lever 14, which engagement serves to maintain the belt on the driving-pulley in the manner hereinbefore described. If, however, the paper becomes entangled on the ends of the fly-fingers, and is thus prevented from passing onto the fly, the detector 1 remains in its normal position in the path of the paper, as shown in Fig. 8 of the drawings, and by this position of the detector the arm 28 is caused to sustain the dog 33 out of the path of the rod 36, which is thus permitted to move longitudinally and to carry the prop 40 to a position to intercept the downward movement of the arm 26, which prevents the arm 23 from engaging the shoulder 24 of the lever 14, which is thereby permitted to actuate the belt-shifting lever K to throw the belt onto the loose pulley, and thus stop the motion of the press.

Another modification of my invention is illustrated in Fig. 9 of the drawings, in which the automatic stop mechanism of the press is controlled by electromagnetic connection with the detector 1. When two of such detectors are arranged at opposite sides of the longitudinal central line of the fly and are movable independently of each other, the electric circuit is to be arranged as shown diagrammatically in Fig. 10 of the drawings. Each of these detectors has affixed to it an electric contact-finger 43, facing one of the poles 44 of a circuit, which is open when the detectors are in their normal positions, as shown. A magnet 45 in the said circuit faces an armature 46, attached to a prop 47, which is pivoted at its lower end to a suitable stationary support, and has its upper free end sustained normally in position to intercept the downward movement of the arm 26, and thus prevent the arm 23 from engaging the lever 14, which is thereby free to shift the driving-belt onto the loose pulley. Consequently the motion of the press is stopped whenever the paper fails to pass from the impression-cylinder onto the fly and leaves the detectors in their normal position. The magnet 45 and armature 46 are so arranged in relation to the prop 47 that the attraction of the armature to the magnet throws the said prop out of its aforesaid normal position, and thereby liberates the arm 26, which allows the arm 23 to engage the shoulder of the lever 14, forced into engaging position by the cam 21, in the manner hereinbefore described, said engagement serving to maintain the belt on the driving-pulley. It is therefore readily perceived that when the printed paper passes properly onto the fly B the paper in transit tilts the detectors 1, and thereby throws the fingers 43 into contact with the poles 44, and the resultant closing of the circuit causes the magnet 45 to throw the prop 47 from under the arm 26, which permits the arm 23 to hold the lever 14 in position to maintain the

press in operation. A further modification is shown in Fig. 11 of the drawings, in which the detector 1 and rock-shaft 6 are located above the fly B. Aside from this change of location provision is made to afford to the person in charge of the press perfect control of the rock-shaft 6 for stopping the motion of the press without requiring him to manipulate the belt-shifting lever K. This control of the rock-shaft is obtained by an arm 48, fastened to the end of said shaft and having connected to its free end a rod 49, which is extended to the usual fly-board or table C, where it is supported in a suitable guide 50 and provided with a suitable handle 51 for manipulating said rod. In this instance the detecting-finger 1 is suspended from a rod 52, supported in arms 53, extending from brackets attached to the press-frame. Said finger 1 is sustained in its normal position by a weighted arm 54, attached to the heel of said finger and resting on a stop 55 on the rod 52. The rock-shaft 6 has fastened to it the arm 7, which by contact with the end of the limb 2 of the detecting-finger 1 controls the movement of said rock-shaft automatically. It is obvious that when the detector and rock-shaft are located above the fly, as aforesaid, the detector-supporting rod 52 and rock-shaft 6 must be placed a sufficient distance from the free end of the fly to prevent said rod and shaft from interfering with the movement of the fly.

What I claim as my invention is—

1. The combination with a printing-press, automatic paper-feeder, mechanisms actuating said press and feeder in common, and delivering means disposed to receive the paper from the impression-cylinder, of stop mechanism organized to automatically arrest the aforesaid actuating mechanism, detectors normally in the path of the paper to the aforesaid delivering means, and mechanism restraining the stop mechanism and controlled by the detectors as set forth.

2. The combination with a printing-press, automatic paper-feeder, mechanisms actuating said press and feeder in common, and delivering means disposed to receive the paper from the impression-cylinder, of stop mechanism organized to automatically arrest the aforesaid actuating mechanism, detecting-fingers sustained normally in the path of the paper on the aforesaid delivering means, a rock-shaft controlled by the detecting-fingers, and means actuated by the rock-shaft and controlling the stop mechanism as set forth.

3. On a printing-press provided with an automatic paper-feeder and with a fly arranged to receive the paper from the impression-cylinder, the combination with the actuating mechanism of said feeder, of detecting-fingers sustained normally in the path of the paper to the fly and yieldingly independent of each other in direction lengthwise of the fly-fingers, limbs projecting from the heels of the detecting-fingers, a rock-shaft disposed

transversely of the fly-fingers, arms projecting from said rock-shaft and in positions to encounter the aforesaid limbs, and thereby limit the action of the rock-shaft, and stop mechanism, for arresting the operation of the feeder and controlled by the action of the aforesaid rock-shaft.

4. On a printing-press provided with an automatic paper-feeder and a fly arranged to receive the paper from the impression-cylinder, the combination, with the actuating mechanism of the feeder, of a bar disposed at right angles to the fly-fingers and parallel to the plane thereof, detecting-fingers pivotally supported on said bar and movable independent of each other in planes parallel with the fly-fingers, means for sustaining said fingers normally in the path of the paper to the fly, limbs projecting from the heels of the detecting-fingers toward one end of the fly, a rock-shaft disposed parallel with the aforesaid bar, arms projecting from said rock-shaft and in positions to encounter the aforesaid limbs, and thereby limit the motion of the rock-shaft, mechanisms actuating said rock-shaft, and stop mechanism for arresting the operation of the feeder and controlled by the actuating mechanism of the aforesaid rock-shaft.

5. On a printing-press provided with a fly arranged to receive the paper from the impression-cylinder, mechanism for automatically supplying the paper to the press, and main actuating mechanisms transmitting motion to said press and paper-supplier in common, the combination of a bar disposed at right angles to the fly-fingers and parallel to the plane thereof, detecting-fingers pivotally supported on said bar and movable independent of each other in planes parallel with the fly-fingers, means for holding said fingers normally in the path of the paper to the fly, limbs projecting from the heels of the detecting-fingers toward one end of the fly, a rock-shaft disposed parallel with the aforesaid bar, arms projecting from said rock-shaft and in positions to encounter the aforesaid limbs and thereby arrest the movement

of the rock-shaft, mechanism actuating said rock-shaft, and stop mechanism for arresting the aforesaid main actuating mechanisms and controlled by the actuating mechanism of the aforesaid rock-shaft as set forth.

6. On a printing-press provided with an automatic paper-feeder, a fly arranged to receive the paper from the impression-cylinder, and main actuating mechanism transmitting motion to the press and feeder, the combination of detecting-fingers sustained normally in the path of the paper to the fly and yieldingly to contact with the paper, a rock-shaft controlled by the action of the detecting-fingers, an oscillatory lever actuating said rock-shaft, a rock-arm controlled by said lever, a press and feeder stopping lever controlled intermittently by said rock-arm, and a cam restraining the action of said stopping-lever while released from said rock-arm as set forth.

7. On a printing-press provided with an automatic paper-feeder and a fly arranged to receive the paper from the impression-cylinder, and main actuating mechanism transmitting motion to the press and feeder, the combination of detecting-fingers sustained normally in the path of the paper to the fly and yieldingly to contact with the paper, limbs projecting from the heels of said fingers, a rock-shaft disposed at right angles to the fly-fingers, arms projecting from said rock-shaft and in positions to encounter the aforesaid limbs and thereby limit the motion of the rock-shaft, an oscillatory lever actuating said rock-shaft and limited correspondingly, a rock-arm controlled by said lever, a lever for stopping the main actuating mechanism controlled intermittently by said rock-arm, and a cam restraining the action of said stopping-lever while released from said rock-arm as set forth.

In testimony whereof I have signed my name to this specification in the presence of two subscribing witnesses.

TALBOT C. DEXTER. [L. s.]

Witnesses:

JOHN K. KNOX,
EUGENE KETCHUM.