

(12) INTERNATIONAL APPLICATION PUBLISHED UNDER THE PATENT COOPERATION TREATY (PCT)

(19) World Intellectual Property Organization
International Bureau



(43) International Publication Date
28 August 2003 (28.08.2003)

PCT

(10) International Publication Number
WO 03/070051 A1

- (51) International Patent Classification⁷: A46B 3/18, 9/02, A46D 1/06, 9/02
- (21) International Application Number: PCT/EP03/02000
- (22) International Filing Date: 13 February 2003 (13.02.2003)
- (25) Filing Language: English
- (26) Publication Language: English
- (30) Priority Data:
0202381 25 February 2002 (25.02.2002) FR
- (71) Applicant (for all designated States except US): COTY SA [FR/FR]; 54, rue de Londres, F-75008 PARIS (FR).
- (72) Inventor; and
- (75) Inventor/Applicant (for US only): MATHIEZ, Jean-Louis [FR/FR]; 36, avenue de la Gare, F-91470 LIMOURS (FR).
- (74) Agents: CABINET ORES et al.; 36, rue de St Petersburg, F-75008 PARIS (FR).
- (81) Designated States (national): AE, AG, AL, AM, AT, AU, AZ, BA, BB, BG, BR, BY, BZ, CA, CH, CN, CO, CR, CU, CZ, DE, DK, DM, DZ, EC, EE, ES, FI, GB, GD, GE, GH, GM, HR, HU, ID, IL, IN, IS, JP, KE, KG, KP, KR, KZ, LC, LK, LR, LS, LT, LU, LV, MA, MD, MG, MK, MN, MW, MX, MZ, NO, NZ, OM, PH, PL, PT, RO, RU, SC, SD, SE, SG, SI, SK, SL, TJ, TM, TN, TR, TT, TZ, UA, UG, US, UZ, VC, VN, YU, ZA, ZM, ZW.
- (84) Designated States (regional): ARIPO patent (GH, GM, KE, LS, MW, MZ, SD, SL, SZ, TZ, UG, ZM, ZW), Eurasian patent (AM, AZ, BY, KG, KZ, MD, RU, TJ, TM), European patent (AT, BE, BG, CH, CY, CZ, DE, DK, EE, ES, FI, FR, GB, GR, IE, IT, LU, MC, NL, PT, SE, SK, TR), OAPI patent (BF, BJ, CF, CG, CI, CM, GA, GN, GQ, GW, ML, MR, NE, SN, TD, TG).
- Published:
— with international search report
- For two-letter codes and other abbreviations, refer to the "Guidance Notes on Codes and Abbreviations" appearing at the beginning of each regular issue of the PCT Gazette.

(54) Title: METHOD OF CUTTING BRISTLES OF A COSMETIC APPLICATOR BRUSH, GUIDE TUBE AND IMPLEMENTING MACHINE, AND CORRESPONDING BRUSH, APPLICATOR SYSTEM AND COSMETIC PRODUCT.

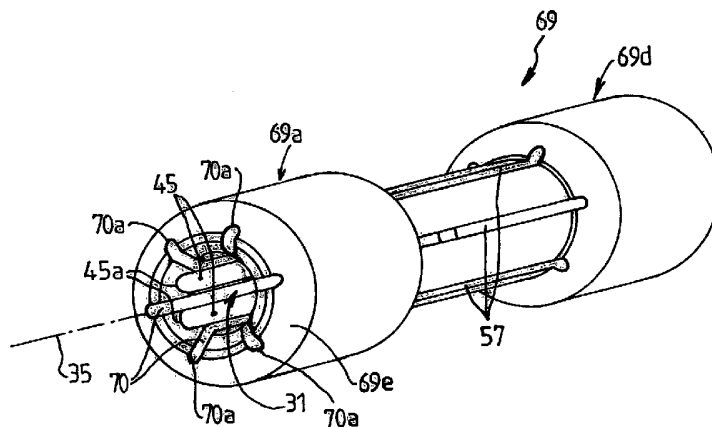

(57) Abstract: In order to apply mascara and comb the eyelashes, the invention proposes carrying out a selective, clean and adaptable cutting of the bristles twisted along a core by selecting some of the bristles located, along the wire, in angular sectors of adjustable amplitude and by continuously cutting the bristles thus selected at a predetermined height. The implementing guiding module has a guiding inlet head (69a) and a cylindrical tube body (69c), the head being for bristles remain curved. The cutting (70) and guiding (45) groove formed by an end piece with a conical outline extended by a hollow tube having a central channel (31) of the same diameter, cutting (70) and guiding (45) grooves being formed in the channel. The cutting grooves (70) are distributed longitudinally in order to select the brush bristles to be left untouched, alternating with grooves (45) for guiding brush bristles to be protected from being cut, the cutting grooves (70) forming, in the tube body, cutting slots (57) and guiding grooves (45) having a depth such that the selected grooves form indentations (45a, 75a) on the end of the end piece. The present invention is mainly applicable to the cosmetic industry.



WO 03/070051 A1

**METHOD OF CUTTING BRISTLES OF A COSMETIC APPLICATOR
BRUSH, GUIDE TUBE AND IMPLEMENTING MACHINE, AND
CORRESPONDING BRUSH, APPLICATOR SYSTEM AND
COSMETIC PRODUCT**

5

The present invention mainly relates to a method for cutting a brush intended for the application of a product for cosmetic use, in particular a pasty product such as mascara to be applied to the eyelashes or eyebrows; it also relates to the guide tube and to the cutting machine for
10 implementing the method, and to the brush cut according to said method and to the applicator system having such a brush, the stem on which it is mounted, and the wiper on which it is wiped.

In general, mascara is packaged in a bottle whose opening is restricted by
15 a wiper, and the brush is mounted at the end of a stem secured to a cap screwed onto the bottle.

In the storage condition, the brush is immersed in the pasty formula of the product and is therefore loaded, that is to say the interstices between the
20 bristles are filled with the paste.

The amount of paste present on the brush is controlled, on coming out of the bottle, by the wiper whose wiping lip, located around its orifice, scrapes off any excess. This orifice is generally circular, with a diameter close to
25 the diameter of the stem and less than the diameter of the brush.

The applicator system has a dual function: to apply the paste and to comb the eyelashes or eyebrows. The control of the amount of paste is determining for the performance of the application system: too small an
30 amount on the brush will not apply enough paste to the eyelashes, giving an insubstantial and inefficient makeup, while too high an amount will not allow the eyelashes and eyebrows to be correctly combed and separated. In the latter case, the makeup will be coarse and inaccurate.

For a given paste formula, it is known from the prior art that the proper amount of paste will be determined by a combination of appropriate diameters for the stem, the brush and the orifice of the wiper. The diameter of the stem is matched to the diameter of the wiper, so as to allow sliding with zero or moderate friction, while preventing the heavy loading of the stem which would be caused by an excessive clearance.

A small-diameter brush passes easily through the orifice of the wiper and keeps a high load of paste since only the ends of the bristles are wiped. However, such a solution is not efficient for combing.

In contrast, a large-diameter brush, that is to say having long bristles, carries too little product after wiping, since the bristles, which are bent back sharply when passing through the orifice, lose a large part of their load.

In addition to the respective dimensioning of the elements of the applicator system, the nature of the fibers used for the brush, and their cross section, their rigidity, their number, etc., are also to be taken into account depending on the texture and the viscosity of the formula in order to improve the performance.

Since the number of parameters linked together is high, designing a wiping system generally leads to a situation of compromise between the various desired qualities: thick coating (volume), separation of the eyelashes (combing), lengthening effect, curving effect, etc.

This compromise is especially difficult to achieve because some parameters change over time:

- the viscosity of the paste changes with temperature;
- the gradual evaporation of the water or solvents contained in the paste also changes its viscosity and its texture;
- the aging of the brush fibers, while immersed in the paste, tends to increase their diameter by impregnation, thereby decreasing their rigidity.

A known method for increasing the performance of an application system consists in using bristles of different lengths on the same brush: the short bristles and the presence of interstices between these bristles make it possible to store the product to be applied to the user's eyelashes, and the
5 long bristles make it possible to properly comb and efficiently separate the eyelashes.

To produce these two types of bristles for the same brush, document US 4 586 520 provides alternating rows formed from long and short
10 bristles, respectively. However, the envelope diameter of the short bristles is substantially greater than the diameter of the stem and of the wiper. They are therefore also wiped when passing through the wiper and then no longer contain enough material during the application.

15 Document US 5 595 198 describes bristle sizes having lengths graduated within a given range. Such a distribution of bristle lengths does not allow the two distinct functions mentioned above for use on applicators to be carried out correctly.

20 Document US 6 279 583 describes methods consisting in twisting the wire in two phases, before and after a sizing operation, so as to mix the short bristles with the long bristles. This method is relatively expensive, and does not allow the two distinct functions mentioned above to be carried out correctly, since the short bristles dispersed between the long bristles are
25 curved by the bending of the latter on passing through the orifice of the wiper.

Thus, none of these documents describe a cutting method. Furthermore, none of the existing cutting methods makes it possible to obtain bristles as
30 short as desired. This is because the known methods use a back plate cutting tool of the "trimmer" type, and the back plate entails a distance between the cutting element and the metal core of the brush at least equal

to its thickness. Furthermore, a safe distance between the blade and the metal core is needed so as not to damage the cutting tool.

5 The invention aims to alleviate the drawbacks mentioned above by making it possible to apply a large amount of mascara in a single application, in order to give volume to the eyelashes, and to comb, separate and curve the eyelashes. It is also an aim of the present invention to provide a mascara brush at a moderate cost price.

10 To achieve these aims, the invention proposes carrying out a selective and clean cut of the bristles by masking some bristles which are not to be cut.

More specifically, the subject of the invention is a method of cutting bristles of an applicator brush for a cosmetic product consisting, based on a brush
15 having a twisted core in which are trapped bristles whose envelope is an axisymmetric surface about the core, produced according to a commonly used method, in separating the bristles of the brush into angular sectors along the core, the bristles intended to be cut are brought together in a line in first cutting sectors, while the bristles of second sectors complementary
20 to the first are folded substantially parallel to the core in order to be left untouched, and in then carrying out an operation of cutting the aligned bristles. After this operation, the folded bristles are released and stand up again due to their own elasticity, in order to form rows of long bristles along the core of the brush.

25

According to particular embodiments:

- the bristles are separated by prior selection of the bristles to be cut and of the bristles to be left untouched into the corresponding sectors;
- 30 - the cutting is carried out over several cutting sectors, either simultaneously or sector by sector.

The invention also relates to a hollow module for guiding brush bristles into which the brush is inserted, comprising a head for selecting the bristles to be cut and to be left untouched, extended along the same axis by a tubular element with longitudinal slots in order to expose the ends of bristles to be cut. The external dimension of the tubular element determines the cutting length.

The selection head has an inlet orifice having a diameter less than the envelope diameter of the brush and of the longitudinal cutting grooves which select the bristles intended to be cut. The grooves may be radial through grooves in order to form slots, or else remain blind.

The tubular element has a central channel with a diameter less than the envelope diameter of the brush and slots continuing on from the cutting grooves. The tubular element has a thickness which determines the length of the bristles emerging from the slots and intended to be cut by at least one cutting tool. This associated cutting tool, which may be a grinding wheel or a milling cutter, with a blade or disk, bears on the tubular element or in the immediate proximity. The cut bristles are advantageously collected by means of a suction device. The cutting tool makes it possible to chop the bristles emerging from the slots corresponding to the cutting of at least one angular cutting sector. The cutting tool may also be a laser beam, a high pressure water jet, an ultrasound device or the equivalent.

According to particular embodiments:

- the longitudinal cutting grooves are formed along the entire length of the guiding module from the orifice of the selection head;
- complementary guiding grooves, intended to guide the folded bristles, are formed longitudinally between the cutting grooves along the entire length of the module from the orifice of the selection head;
- the cutting and guiding grooves are formed in the selection head with a depth such that the selected bristles remain folded down, and

the cutting grooves are distributed regularly alternating with the grooves for guiding brush bristles to be left untouched;

- the cutting slots are arranged along the axis of the tubular element or along a helical path with a pitch having a length at least five to ten times greater than the pitch of the twisted core of the brush, the angular distribution of the slots depending on the overall size of the cutting tools;

- the tubular element has notches around the cutting slots in order to cut as closely as possible to the core;

- the tubular element has a conicity of up to 10 to 15° on the outer face having the slots in order to vary the length to which the bristles are cut depending on the axial position of the cutting tool bearing on this face;

- the selection head has an inner frustoconical mouthpiece intended to make it easier to insert the brush by producing a funnel effect;

- the selection head has an outer frustoconical end, the intersection between the cutting grooves and the frustoconical end forming notches improving the selection;

- the slots or the cutting grooves have, around the frustoconical mouthpiece, an opening which flares out to the end of the head, it being possible for this width to be adjusted by bending the guiding slots by exerting a radial pressure on the end piece, especially by an adjustment ring, in particular one which is conical or has a variable diameter; such an adjustment varies the opening of the cutting grooves on the selection head and therefore the angle of the sectors of cut bristles.

Advantageously, the brush is self-centering in the guiding module because of the statistically even distribution of the bristles around the core of the brush, which therefore positions itself automatically on the axis of the guiding module.

The invention also relates to a cutting machine equipped with such a module, bristle cutting means associated with the cutting slots, motor

means for rotating the tube and/or the cutting tools, at a speed of up to 30 000 rpm, preferably between 5 and 20 000 rpm, it being possible for the tube to be mounted on support bearings, and loading and centering means and means for rotating the in-going brushes before they are inserted into
5 the cutting tube.

According to particular embodiments, flat or annular cutting means, especially in the form of a straight or circular blade, are placed around the tube and associated with the cutting slots.

10

The invention also relates a brush cut according to the method above, and to the applicator system comprising such a brush, a stem for supporting a cylindrical brush, having a diameter of between 3 and 5 mm, and a wiper made of a flexible thermoplastic, elastomer or thermoplastic elastomer
15 material, provided with an orifice having a diameter of between 2 and 6 mm.

According to a preferred embodiment, the brush of the applicator system comprises longitudinal rows of bristles of different lengths, the bristles of at
20 least one of these rows having a length such that the bristle ends are inscribed within the envelope profile of the stem, itself substantially equal to the profile of the opening of the wiper, by adjustment to higher or lower values.

25 The invention also relates to the cosmetic product having such an applicator system associated with a corresponding cosmetic formula.

Other features and advantages of the invention will become apparent on reading the description below and the appended figures, given as
30 nonlimiting examples, and which show respectively:

- figure 1, a general sectional view of a packaging for applying mascara equipped with an applicator system according to the prior art;

- figures 2a to 2c, schematic end views of brushes cut by the method according to the present invention;
- figures 3a to 3c, front and rear isometric views and lateral sections of an exemplary brush according to the invention;
- 5 - figure 4, a view in schematic cross section illustrating a first exemplary bristle-cutting method according to the present invention;
- figure 5, a view in schematic cross section illustrating a second exemplary bristle-cutting method according to the present invention;
- 10 - figure 6, a view in schematic cross section illustrating a third exemplary bristle-cutting method according to the present invention;
- figure 7, a partial perspective view of a first embodiment of a cutting guide tube associated with a flat cutting blade;
- figure 8, a perspective view of the head of the guide tube
15 according to figure 7;
- figure 9, an end view of the head of the guide tube according to figure 7;
- figure 10, a complete isometric view of the guide tube according to figure 7;
- 20 - figure 11, a perspective view of an exemplary guide tube with continuous and adjacent slots;
- figure 12, a perspective view of an annular ring for clamping the guide head according to figure 9;
- figures 13a to 13c, perspective views of the second
25 embodiment of the cutting tube according to the present invention;
- figures 14a and 14b, sectional and side views of two annular rings for clamping the guide head according to figures 13a to 13c; and
- figures 15a and 15b, a sectional view with partial enlargement of a cutting machine according to the present invention.

30

In all the figures, identical reference signs denote identical or similar elements.

As is apparent in the sectional view of figure 1, a mascara applicator system 1 conventionally consists of a cap 2, on which a head 3a of the stem 3, coupled at its end to a mascara brush 4, is mounted securely, the cap and the stem being screwed onto an element in the shape of a tubular body 5 containing the mascara. The neck of this tube 5 is internally equipped with a wiper 6 fitted with a circular lip 6a which presses against the stem 3. The wiper is made from a flexible thermoplastic, from LDPE (low-density polyethylene) or from an elastomer, for example of the TPE (thermoplastic elastomer) type or neoprene type.

10 According to a common method, the mascara brush 4 is produced from a metal wire 7 forming the linear central core of the brush. Fibers, for example made of polyamide or from synthetic or natural, hollow or solid materials, are distributed between two branches previously curved into a U shape. The plastically deformable wire is twisted in order to entrap the fibers in the form of bristles 8 distributed regularly along a helix. The ends of the bristles are evened out in the shape of an axisymmetric (cylindrical, conical, frustoconical, etc.) envelope by means of a cutting operation. In the example illustrated in figure 1, the outer envelope of the brush fibers is cylindrical with a circular cross section.

20

After operations of assembling and filling with mascara, the cap is screwed on to the bottle, and the bristles 8 are immersed in the mascara 20. At that moment, the brush 1 is heavily loaded with mascara. Removing it from the bottle makes the bristles 8 pass through the middle of the circular lip 6a of the wiper 6 which removes excess product.

25

In order to distribute the mascara in an advantageous manner over the brush, the method according to the present invention cuts off some bristles located in predetermined angular sectors along the twisted core. The cut reduced the length of the bristles, the bristles cut in this way are subsequently called short bristles. The ends of the short bristles are inscribed within an envelope of diameter "d" which is substantially equal to the diameter of the stem, and substantially equal to the diameter of the

30

circular lip 6a, for example to within ± 0.2 mm. Under these conditions, the mascara trapped between the bristles is not removed from the brush 4 when this brush passes through the lip 6a of the wiper 6.

5 As emerges from figures 2a to 2c, the cut forms three, four or six alternating sectors of short bristles 9 and of uncut bristles 8, called long bristles, as opposed to short bristles. According to variants, the cutting can take place in a helical spiral having a pitch which is large with respect to the pitch of the twists, for example, five to ten times greater. The height H
10 (figure 2a) of the short bristles corresponds to a radius measured from the center of the wire, that is to say to half the diameter "d" (figure 2c) of the envelope cross section of the short bristles 9. The long bristles 8 form a cylindrical envelope having a diameter "D" in cross section (figure 2b).

15 The sectors 10 (figure 2c) having long bristles 8 of angle α are evenly distributed about the core of the wire 7. These sectors are distributed alternately with the sectors 11 of short bristles 9, of angle β , also evenly distributed around the wire 7.

20 In the example illustrated in figure 2c:

$$\alpha = 30^\circ, \beta = 30^\circ$$

envelope diameter "D" of the long bristles: 7 mm

(5 to 8 mm in other examples)

envelope diameter "d" of the cut bristles: 3.8 mm;

25 envelope diameter of the twisted core: 1.5 mm.

Alternatively, the brushes have sectors which are not evenly distributed angularly, together with sectors having different angles for bristles of the same length.

30

One of the brushes according to one of figures 2a to 2c is mounted on a stem 3 (figure 1) having a diameter equal to 4 mm, which corresponds substantially to that of the envelope of the short bristles. The opening

diameter of the lip 6a of the wiper 6 is also equal to 4 mm. More generally, the opening diameter of the wiper is between about 2 and 6 mm, and the corresponding envelope diameter of the stem and of the short bristles is between 3 and 5 mm.

5

As the brush 4 passes through the lip 6a, the latter closes on the long bristles 8 of the sectors 10 which are wiped, while keeping a considerable amount of mascara in the sectors 11 provided with short bristles 9. The stem, the brush and the wiper form an applicator system according to the invention. In this assembly, the stem, the brush and the opening of the wiper have substantially identical dimensions of the envelope profile.

10

A brush according to the invention, as illustrated in the front and rear isometric views and in lateral section in figures 3a to 3c, is presented under ideal conditions to ensure mascara is applied to the eyelashes. Specifically the brush 4 is provided with a large amount of mascara, while having long bristles 8 making it possible to brush, separate and possibly to curve the user's eyelashes. A uniform layer with a considerable thickness of mascara giving volume to the eyelashes is also applied by the short bristles 9.

15

20

The brush is trimmed in the sectors 11, with a shape which is initially conical from the end 12, then cylindrical. Similarly, the long bristles 8 have a conical shape at the end 12, so as to obtain a slender profile.

25

Figures 4 to 6 illustrate schematically three examples of cutting bristles of a mascara brush according to the present invention. A single fiber, corresponding to two diametrically opposed bristles 8, symbolically represents the brush. A grid or a plate 17 with a slot 19, for example a rectangular slot, selects the bristles 8 to be cut. To cut the bristles along a considerable length, the grid 17 is applied directly to the twisted wire 7 and the thickness of the grid 17 is small. This thickness corresponds substantially to the length of the cut bristles. A blade 21 moving alternately in the direction of the double arrow 23 cuts the bristle 8 by shearing

30

between the cutting edge 25 of the blade 21 and the edge 27 of the slot 19. The grid 17 may have a thickness which varies depending on the desired cutting height, for example in order to obtain a conical cut at the brush end, as illustrated in figures 3a to 3c.

5

In figure 5, the cutting device has two blades 21 and 21' placed substantially facing each other. These blades move one with respect to the other in the direction of the double arrows 23 and/or 23', chopping the bristles 8 by shearing them. The device of figure 5 may be fitted with
10 guiding means (not shown), especially with respect to the twisted wire 7. The length of the bristle after cutting depends on the position of the blades 21 and 21', and on the thickness of the blade 21' placed nearest the twisted wire.

15 In figure 6, the bristles 8 are severed by a blade 21 applied to a first side of the bristle, the opposite side of which rests on a support or anvil 21". The blade 21-anvil 21" assembly may be brought closer to the twisted wire 7 in order to reduce the length of the bristle after cutting, or in contrast, be moved away there from in order to increase its length.

20

Annular, and especially circular, rotating blades other than linear blades moving with a flat alternating movement, as shown in figures 4 to 6, may be implemented.

25 To obtain a meticulous cut, a hollow tube 29 made of treated Z38 steel is used in order to form a guiding module consisting of a head and of a tubular body for guiding the bristles. This tube is used in cooperation with cutting means, as illustrated in figures 7 to 10 of a first embodiment.

30 The tube 29 has a central channel 31 for receiving the brush 4. The brush (not shown) is inserted through the inlet orifice 31a of the channel 31 in the direction of the arrow 33. The orifice 31a has a diameter less than the envelope diameter of the brush.

In the example illustrated, the tube 29 has as an end piece, after machining, the conical receiving head 29a extended by a cylindrical body 29b. The straight channel 31 extends over the entire length of the tube and corresponds substantially to its longitudinal axis 35. The channel 31 has longitudinal slots 37, only one of which is shown in figure 7, in order to select the bristles to be cut. The slots are obtained by wire electrical discharge machining.

10 In the example illustrated in figures 8 to 10, the tube 29 has with a channel 31 comprising five longitudinal slots 37, evenly distributed angularly. These slots correspond to five cutting sectors provided with bristles having, after cutting, a shorter length. Each slot 37 opens out into a cutting region 39 on the surface of the tube 29b where a blade 41 severs the bristles which
15 stick out. The tube 29b is provided with five cutting regions 39, each one associated with a cutting blade 41. The regions 39 are offset angularly with respect to each other and axially along the axis 35 (figure 10).

In the example illustrated, each region 39 is formed from a notch, of flat shape (figure 7) or slightly curved (figure 10), to which the blade 41, having a rectangular parallelepipedal shape, is matched. A V-shaped opening 43 with beveled slopes has been made in this flat section, the open side of the V being directed towards the opening of the channel inlet 31.

25 The channel 31 also has guiding grooves 45 located on the bisector of two consecutive slots 37. These grooves, of semicylindrical shape, form indentations 45a at the end of the channel 31. These indentations and the grooves provide fine, therefore improved, selection, and strict guiding of bristles protected from cutting. Since the distance between the bottom of the grooves and the axis of the channel 31 is less than the height of the
30 bristles selected, these bristles are curved and no part projects out of the slot 37. This accurate selection of the bristles not to be cut causes accurate selection of the bristles to be cut.

In the example illustrated, an automatic means, such as a pusher with linear alternating movements (shown below), introduces the brushes into the channel 31 in the direction of the arrow 33. The bristles that it is desired to cut are positioned continuously and automatically in the slots 37 and poke out in the cutting regions 39. The movement of the brush with respect to the guiding device 29 ensures the bristles are cut in the V-shaped region 43 of the blade 41. Furthermore, the blade 41 may undergo a sideways or vibratory movement in order to facilitate the cutting of the bristles. The blade may undergo a vibratory movement in the direction of the axis 65. Such a movement combined with a curved shape of the cutting slot makes it possible to cut with a variable and matched height.

The brush is then recovered at the exit from the channel 31, then is assembled onto a stem.

In the exemplary embodiment, the channel 31 is obtained by a central drilling having a diameter of 2 mm, from which extend semicylindrical grooves 45 having a diameter of 0.8 mm. The diameter of a circle passing through the outer ends of the grooves 45 extends radially to a distance of 2.8 mm. The slots 37 have a width of 0.4 mm and a height of 4 mm from the axis 35 passing through the center of the channel 31. The slots 37 open out into the cutting region 39 at a distance from the axis 35 of approximately between 1 and 2 mm.

According to another exemplary embodiment illustrated in figure 11, the slots 57 of the tube 49 are continuous from the guiding head to the body of the tube. The device 49 has a straight channel 51 for receiving the brushes, which are inserted through the inlet opening of the channel, as in the previous exemplary embodiment.

In the example illustrated, the tube 49 is provided, after machining, with a cylindro-conical head 49a, extended by a cylindrical body 49b having a

smaller diameter. The channel 51 has six longitudinal slots 57 which select and orient the bristles to be cut. These slots are evenly distributed, forming six equal angular sectors for selecting the bristles to be cut. Each slot 57 has a width which decreases linearly over the conical part of the end piece 5 49a, then remains constant over the cylindrical parts of the head 49a and of the body 49b of the tube. A cutting region 59 is made on the surface of the device 49 where an annular blade 61 severs the bristles which pass through.

10 As illustrated in figure 12, a ring 60 is provided for centering the brushes on the tube axis. This ring is snap-fastened in the direction of the arrow 63. By suitable clamping, this ring also adjusts the width of the selecting slots in the conical region of the head 49a, so as to alter the width of the short bristle sectors.

15

In the exemplary embodiments illustrated in figures 7 to 11, the height of the short bristles is located within a cylindrical envelope having a diameter equal to about 3 mm. As required, this diameter corresponds substantially to the diameter of the opening of the wiper. The channel 51 consists of a 20 cylindrical bore having a diameter of 2.2 mm, in which the semicylindrical grooves 65 have a diameter of 0.4 mm and the slots 57 have a width of between 0.7 and 0.4 mm over the conical part of the head 49a. In the tubular part, the slots have a width of 50 mm.

25 As illustrated in figures 13a to 13c of a second embodiment, the guiding module 69 shown in perspective views has a guiding head 69a with a bi-frustoconical end piece extended by a cylindrical part 69b followed by a tube body 69c, which is also cylindrical, but having a much smaller diameter. First cutting grooves 70, distributed longitudinally in the bore of 30 the tube, select the brush bristles to be cut. Alternating with these first grooves, second guiding grooves 45 select the brush bristles to be left untouched, as in the first embodiment.

The first cutting grooves 70 are formed by parallel walls and a cylindrical bottom. These grooves are deep enough not to curve the bristles. These grooves 70 form indentations 70a on the end piece 69a and extend into the body of the tube 69c in order to form the cutting slots 57. The second
5 guiding grooves 45 are semicylindrical, inscribed within an envelope having a diameter equal to 3 mm, so as to curve the selected bristles. These grooves also form indentations 45a on the end piece 69a.

The end piece 69a has a bi-frustoconical shape at the end, the outer
10 truncated cone 69e converges toward the axis 35 of the tube when moving away from the tubular body 69c, while the inner truncated cone 69i diverges in this same direction. Under these conditions, the indentations 70a of the selecting and cutting grooves 70 are formed on the outer truncated cone, while the indentations 45a of the guiding grooves 45 are
15 cut into the inner truncated cone. The body of the tube 69c is extended, away from the guiding head 69a, by a holding and rotationally driving end piece 69d.

As illustrated by the sectional and perspective views of figures 14a and
20 14b, an annular centering ring 80 can be adapted to the guiding head 69a of figures 13a to 13c. This ring makes it possible to improve the guiding by an effect of the "funnel" type.

An example of a cutting machine according to the invention is illustrated by
25 the views in longitudinal section of figures 15a and 15b.

The cutting machine 90 is equipped with a base 90a on which are set: a cutting tube such as the tube 69, a cutting blade such as the blade 41 mounted on the tube against the cutting slots, a driving pulley 91 for
30 rotating the cutting tube at the speed of 20 000 rpm, the tube being mounted on roller bearings 92a and 92b. A thrust rod 93 successively brings, by an alternating movement, the brushes 4 into a centering tube 94 from a loading region 96. In this region, a loading trough 95 is provided.

Before entering the end piece 69a, the brush is made to rotate in a rotating tube 96 also mounted on the bearing 92b. A centering chuck 97 is also provided in order to couple the tube 69 to the drive pulley 91.

- 5 The present invention is not limited to the exemplary embodiments attached and shown. It is for example possible, after having carried out the trimming, to curve the twisted wire so as to obtain an improved application. Moreover, other trimming methods can be envisaged without departing from the scope of the present invention: for example, the regularly split
10 conical or cylindrical guiding device undergoes an alternating or rotating movement while the cutting blades are fixed or also moveable.

Moreover, the blades may be formed by linear or circular cutting strips. Furthermore, the grooves may have different shapes: conical, cylindrical,
15 V, etc.

The present invention is mainly, but not exclusively, applicable to the cosmetic industry.

CLAIMS

1. A method of cutting bristles of an applicator brush for a cosmetic product consisting, based on a brush having a twisted core (7) in which are trapped bristles (8) whose envelope is an axisymmetric surface about the core, produced according to a commonly used method, in separating the bristles of the brush into angular sectors along the core, the bristles intended to be cut are brought together in a line in first cutting sectors, while the bristles of second sectors complementary to the first are folded substantially parallel to the core in order to be left untouched, and in then carrying out an operation of cutting the aligned bristles, the folded bristles being released in order to form rows of long bristles along the core of the brush.
2. The cutting method as claimed in claim 1, in which the bristles are separated by prior selection of the bristles to be cut and of the bristles to be left untouched into the corresponding sectors.
3. The cutting method as claimed in claim 1, in which the cutting is carried out on several cutting sectors (11), either simultaneously or sector by sector.
4. A module for guiding bristles of a brush in order to implement the cutting method according to any one of the preceding claims, comprising a head (29a, 49a, 69a) for selecting the bristles to be cut and to be left untouched, extended along the same axis (35) by a tubular element (29b, 49b, 69c) with longitudinal slots (57) in order to expose the ends of the bristles to be cut, and in which the external dimension of the tubular element determines the cutting length.
5. The guiding module according to the preceding claim, in which the selection head (29a, 49a, 69a) has an inlet orifice (31a) of a central channel (31) having a diameter less than the envelope diameter of the

brush and of the longitudinal cutting grooves (70) which select the bristles intended to be cut.

5 6. The guiding module as claimed in claim 5, in which the grooves are radially blind.

7. The guiding module as claimed in claim 5, in which the grooves are radial through grooves in order to form slots (37).

10 8. The guiding module as claimed in any one of claims 4 to 6, in which the tubular element (29b, 49b, 69c) has cutting slots (57) continuing on from the cutting grooves (70), and in which the tubular element has a thickness which determines the length of the bristles emerging from the slots (57) and intended to be cut by at least one cutting tool (41, 61) in at
15 least one angular sector (11).

9. The guiding module as claimed in the preceding claim, characterized in that the associated cutting tool is a grinding wheel or a milling cutter, with a blade or disk, which bears on the tubular element
20 (29b, 49b, 69c) or in the immediate proximity.

10. The guiding module as claimed in any one of claims 4 to 9, in which the cut bristles (9) are advantageously collected by means of a suction device.
25

11. The guiding module as claimed in any one of claims 4 to 10, in which the cutting tool is chosen from a laser beam, a high-pressure water jet and an ultrasound device.

30 12. The guiding module as claimed in any one of claims 4 to 11, in which the longitudinal cutting grooves (70) are formed along the entire length of the guiding module (69) from the orifice (31) of the selection head (69a).

13. The guiding module as claimed in any one of claims 4 to 12, in which complementary guiding grooves (45), intended to guide the folded bristles, are formed longitudinally between the cutting grooves (70) along the entire length of the module (69) from the orifice (31) of the selection head (69a).

14. The guiding module as claimed in the preceding claim, in which the cutting (70) and guiding (45) grooves are formed in the selection head (69a) with a depth such that the selected bristles remain folded down, and the cutting grooves (70) are distributed evenly alternating with the grooves (45) for guiding those brush bristles which are to be left untouched.

15. The guiding module as claimed in any one of claims 4 to 14, in which the cutting slots (57) are arranged along the axis (35) of the tubular element (29b) or along a helical path with a pitch having a length five to ten times greater than that of the pitch of the twisted core (7) of the brush, the angular distribution of the slots (37, 57) depending on the overall size of the cutting tools.

16. The guiding module as claimed in any one of claims 4 to 15, in which the tubular element has notches (39) around the cutting slots (57) in order to cut as closely as possible to the core.

17. The guiding module as claimed in any one of claims 4 to 15, in which the tubular element has a conicity of up to 10 to 15° on the outer face having the slots (57) in order to vary the length to which the bristles are cut depending on the axial position of the cutting tool bearing on this face.

18. The guiding module as claimed in any one of claims 4 to 17, in which the selection head (69a) has an inner frustoconical mouthpiece (69i) intended to make it easier to insert the brush by producing a funnel effect.

19. The guiding module according to the preceding claim, in which the selection head (69a) has an outer frustoconical end (69e), the intersection between the cutting grooves (70) and the frustoconical end (69a) forming indentations (70a) which improve the selection.

20. The guiding module as claimed in either of claims 18 and 19, in which the slots (37) or the cutting grooves (70) have, around the frustoconical mouthpiece, an opening which flares out to the end of the head (69a).

21. The guiding module as claimed in the preceding claim, in which the width of the opening is adjusted by bending the guiding slots by exerting a radial pressure on the end piece in order to vary the opening of the cutting grooves (70) on the selection head (69a) and the angle of the sectors of cut bristles (9).

22. The guiding module as claimed in the preceding claim, in which the adjustment is carried out by a conical adjustment ring.

23. The guiding module as claimed in any one of claims 4 to 22, in which the brush is self-centering in the guiding module (29, 49, 69) because of the statistically even distribution of bristles (8) around the core of the brush, which therefore positions itself automatically on the axis of the guiding module.

24. A cutting machine equipped with a module as claimed in any one of claims 4 to 23 and with bristle cutting means associated with the cutting slots (57), in which are provided motor means for rotating the tube and/or the cutting tools, at a speed of up to 30 000 rpm, the tube being mounted on support bearings, and loading and centering means and means for rotating the brushes before they are inserted into the cutting tube.

25. The cutting machine as claimed in the preceding claim, in which the drive speed is between 5 and 20 000 rpm.

26. The cutting machine as claimed in either of claims 24 and 25, in which the flat or annular cutting means, especially in the form of a straight or circular blade, are placed around the tube and associated with the cutting slots (57).

27. A brush cut according to the cutting method as claimed in any one of claims 1 to 3, as implemented by the machine according to any one of claims 24 to 26.

28. The brush as claimed in the preceding claim, having longitudinal rows of bristles of different lengths, the bristles of at least one of these rows having a length such that the bristle ends are inscribed within the envelope profile of the stem, itself substantially equal to the profile of the opening of the wiper.

29. An applicator system having a brush according to either of claims 27 and 28, a stem on which the brush is mounted, and a wiper on which it is wiped, the stem, the short bristles (9) of the brush and the wiper having a substantially identical diameter.

30. The applicator system as claimed in the preceding claim, in which the brush support stem has a diameter of between 3 and 5 mm, and the wiper, made of a flexible material, is provided with an orifice having a diameter of between 2 and 6 mm.

31. A cosmetic product comprising an applicator system according to either of claims 29 and 30 associated with a corresponding cosmetic formula.

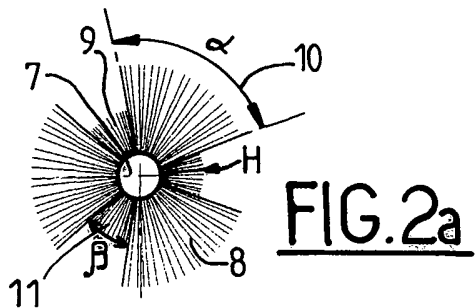

FIG. 2a

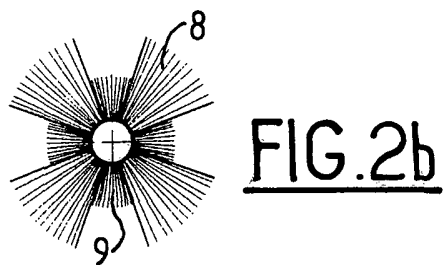

FIG. 2b

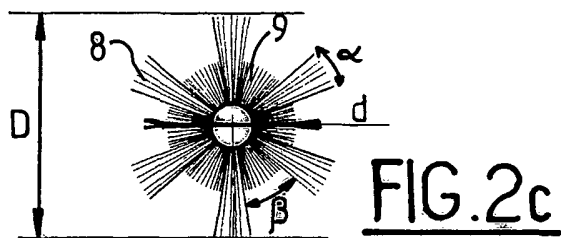

FIG. 2c

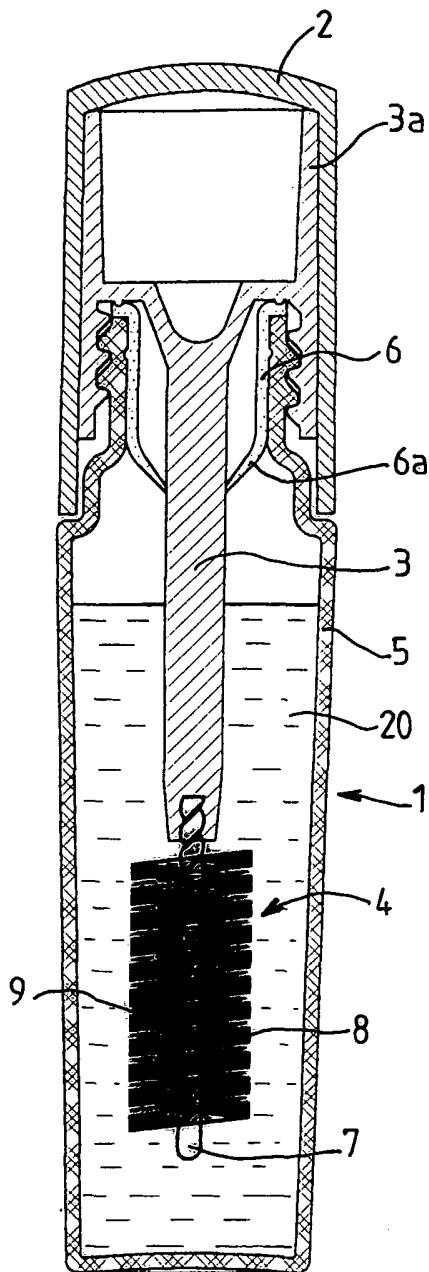

FIG. 1

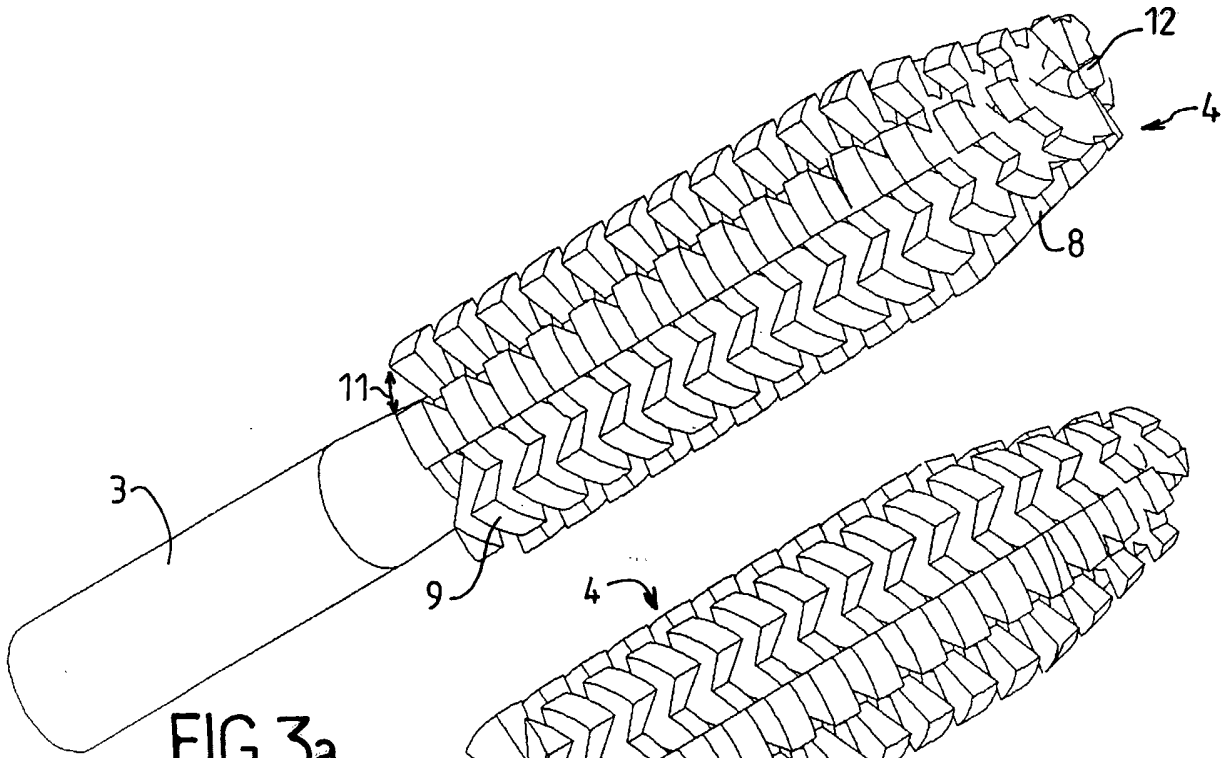

FIG. 3a

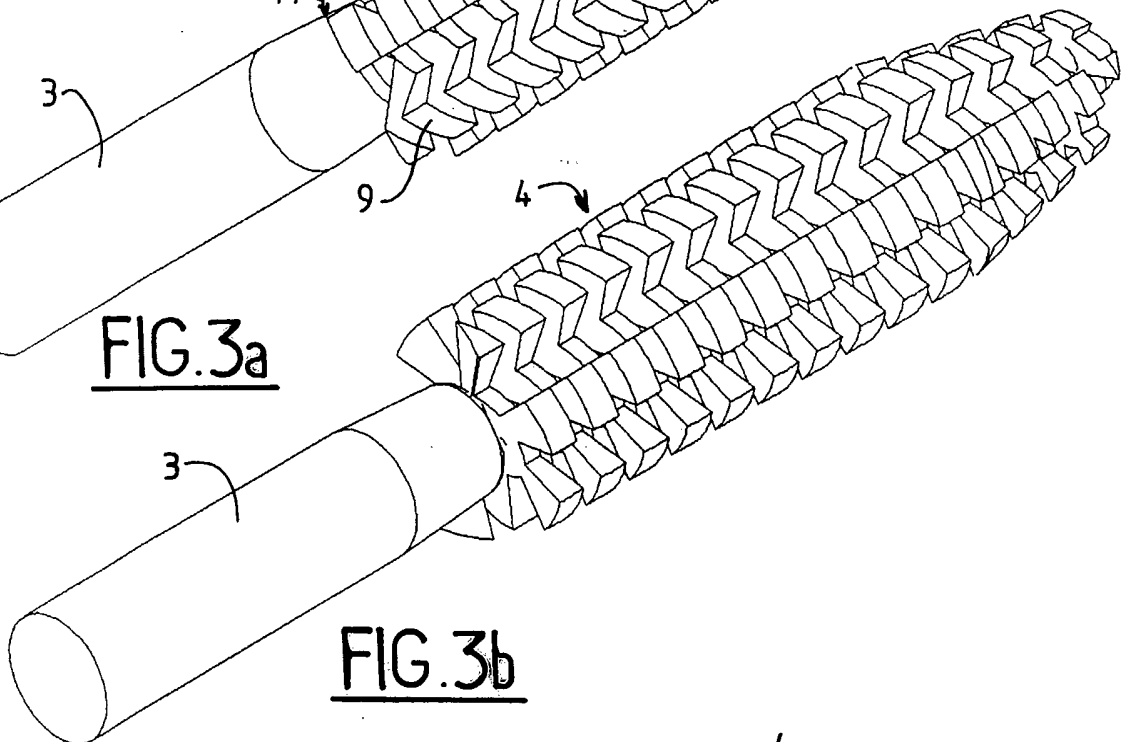

FIG. 3b

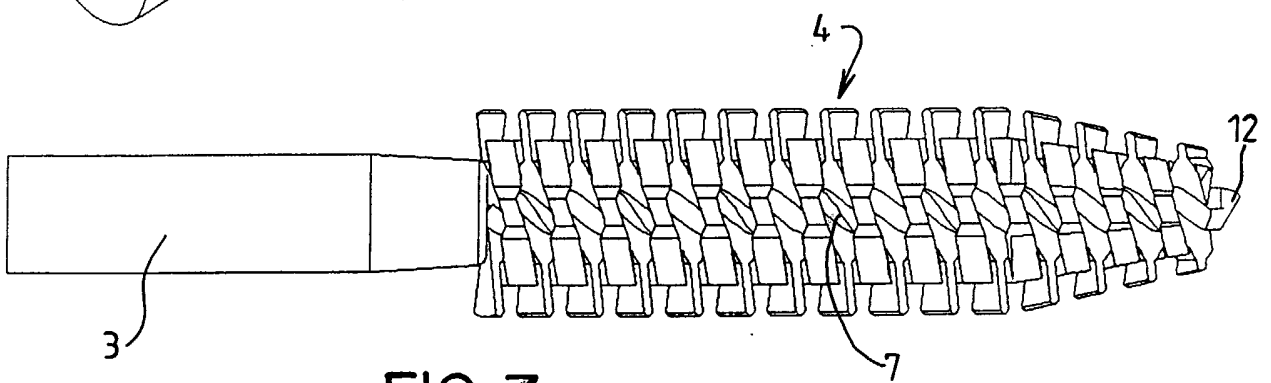

FIG. 3c

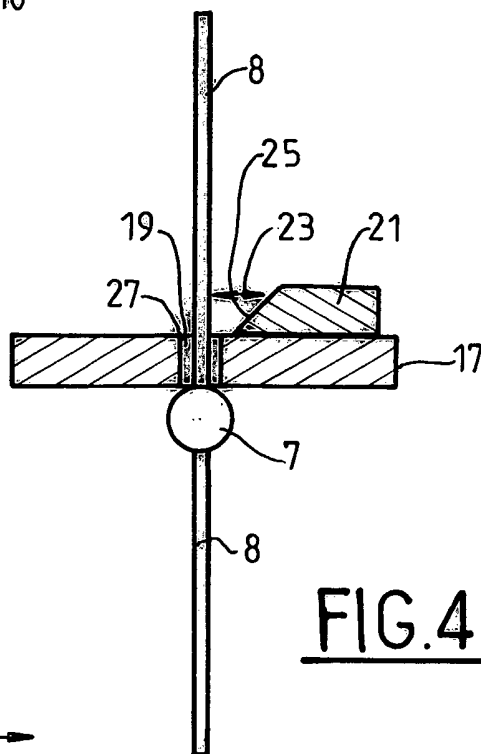

FIG. 4

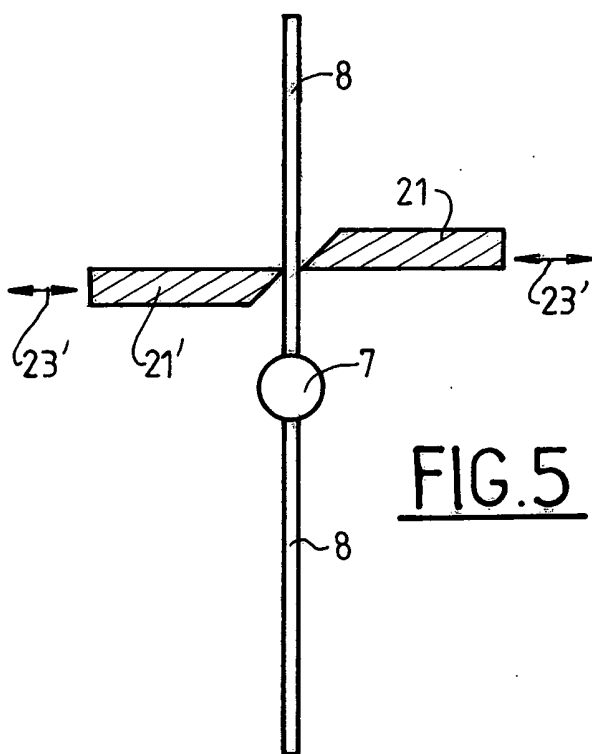

FIG. 5

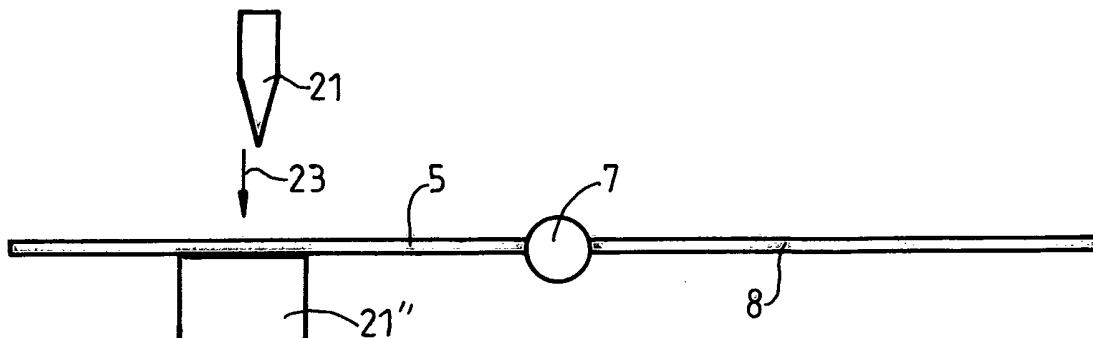

FIG. 6

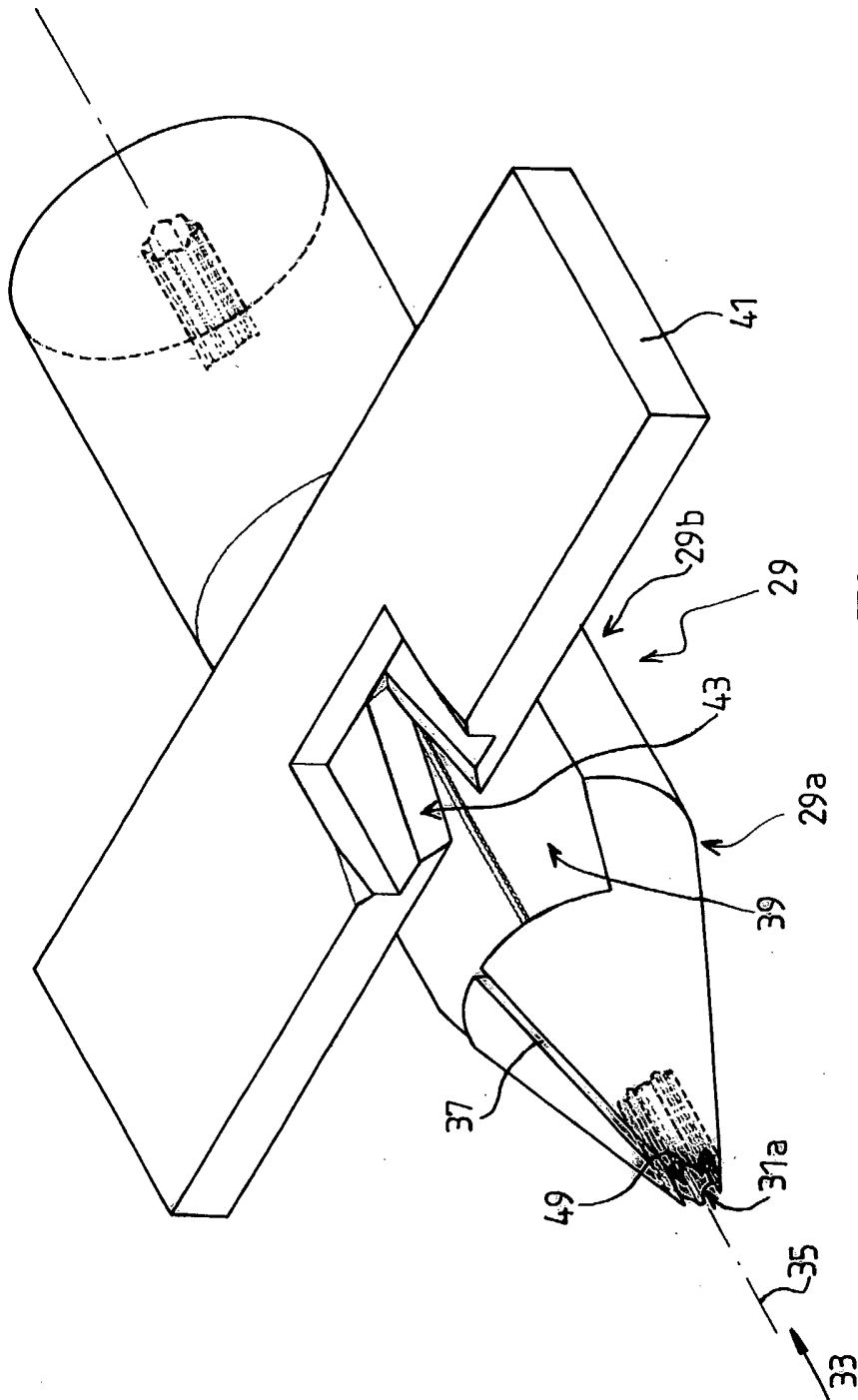

FIG. 7

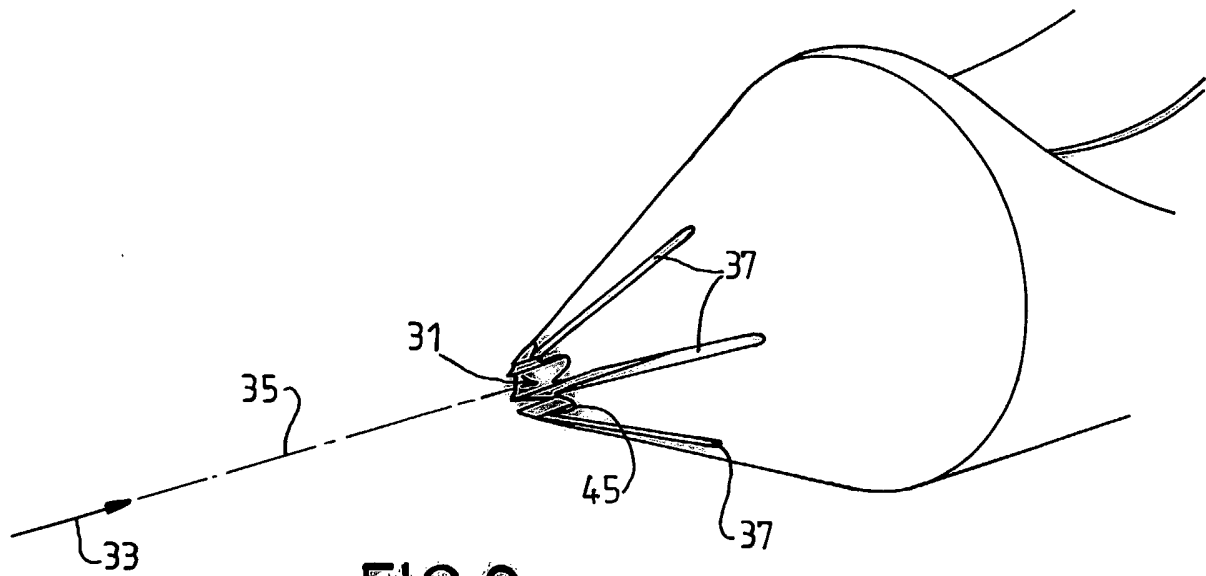

FIG. 8

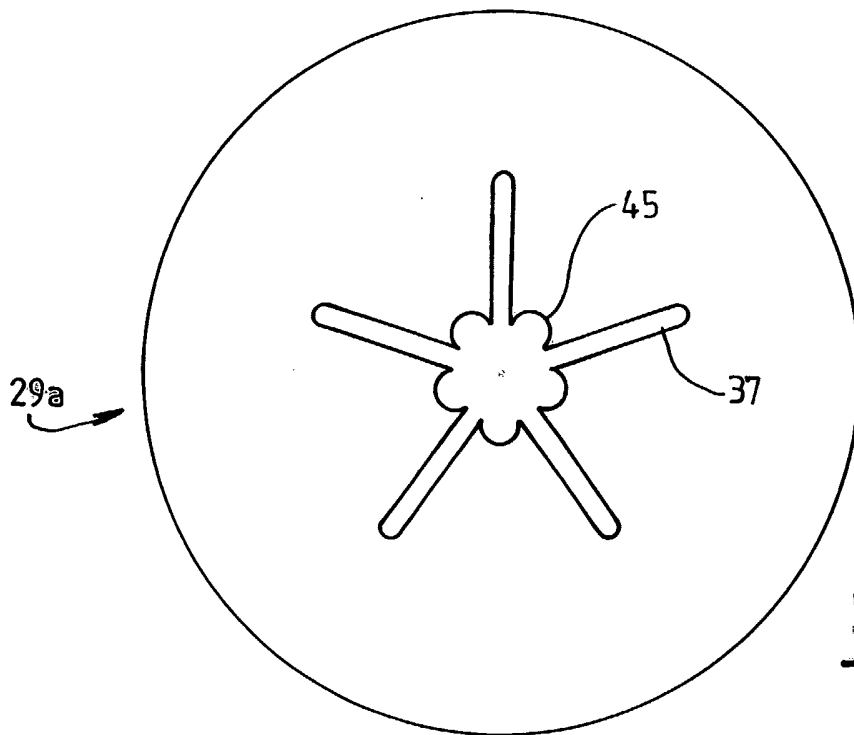

FIG. 9

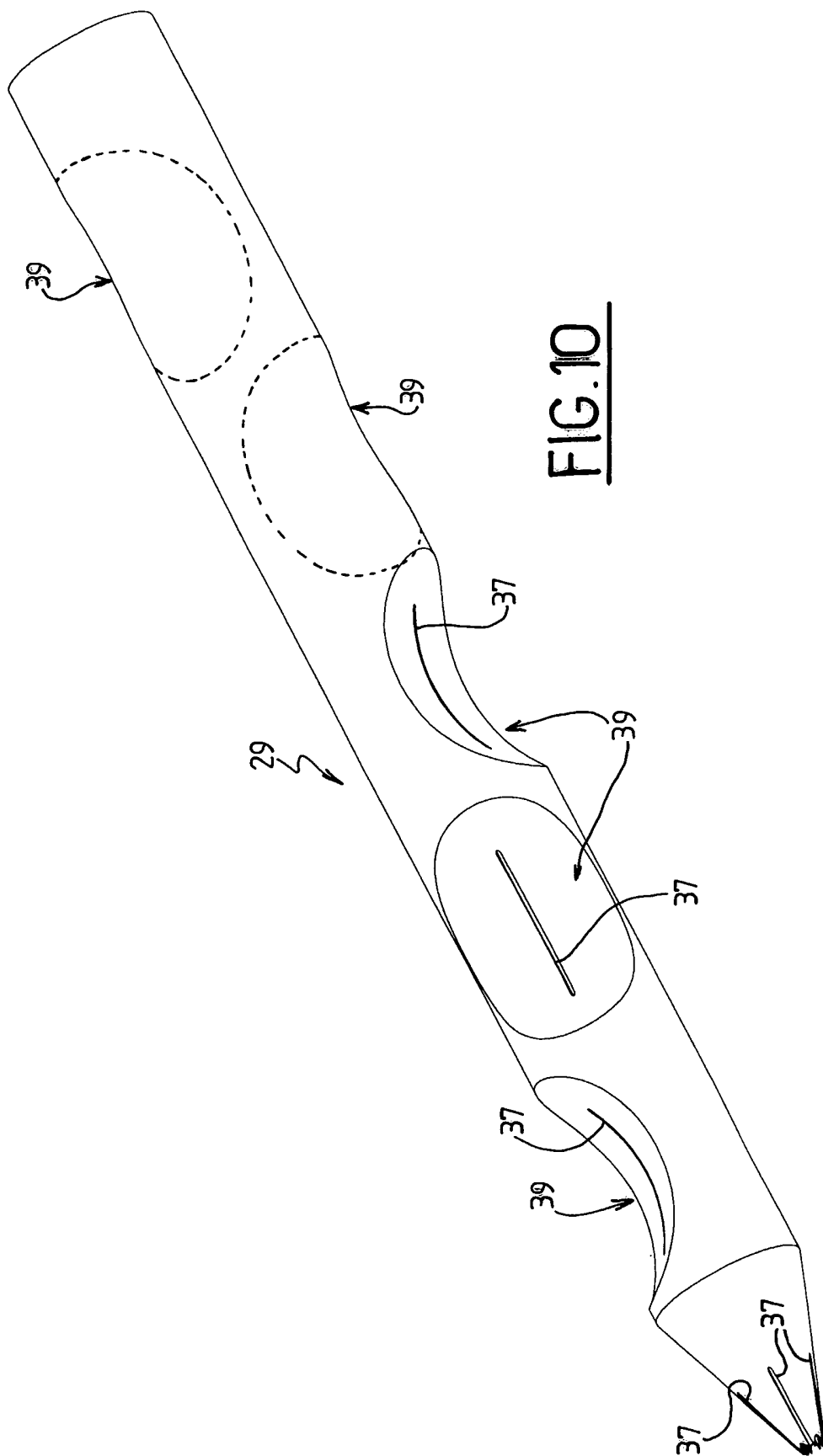

FIG. 10

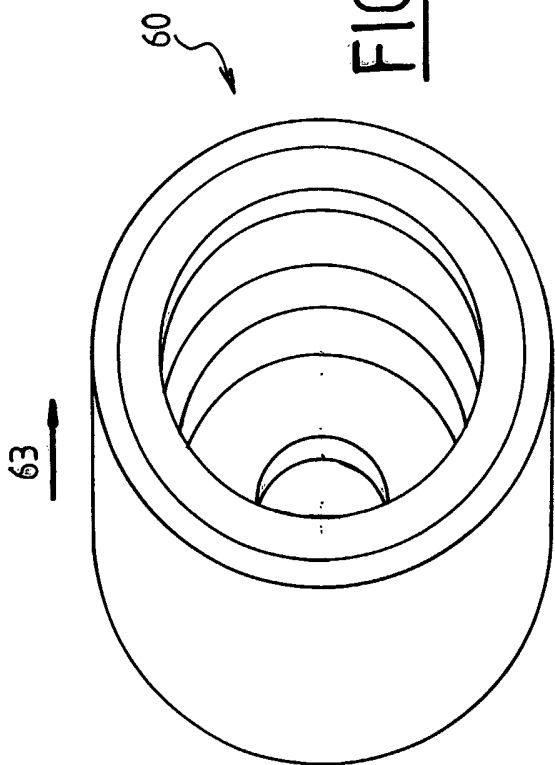

FIG. 12

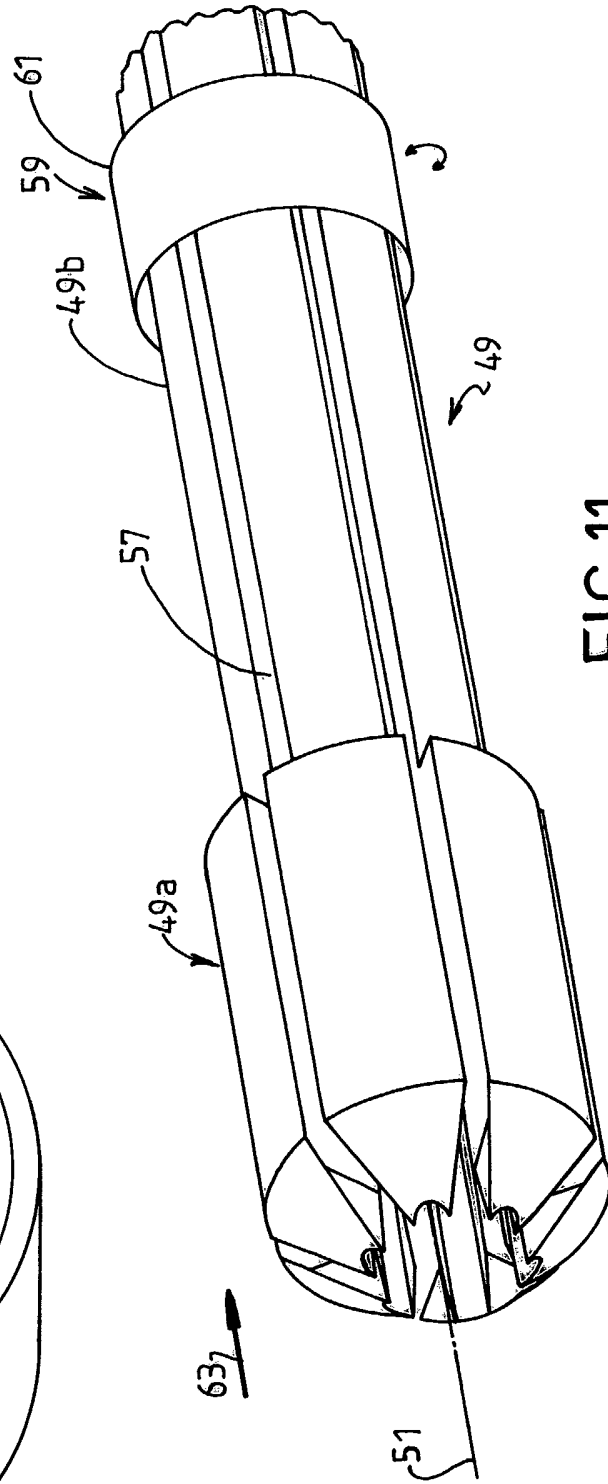
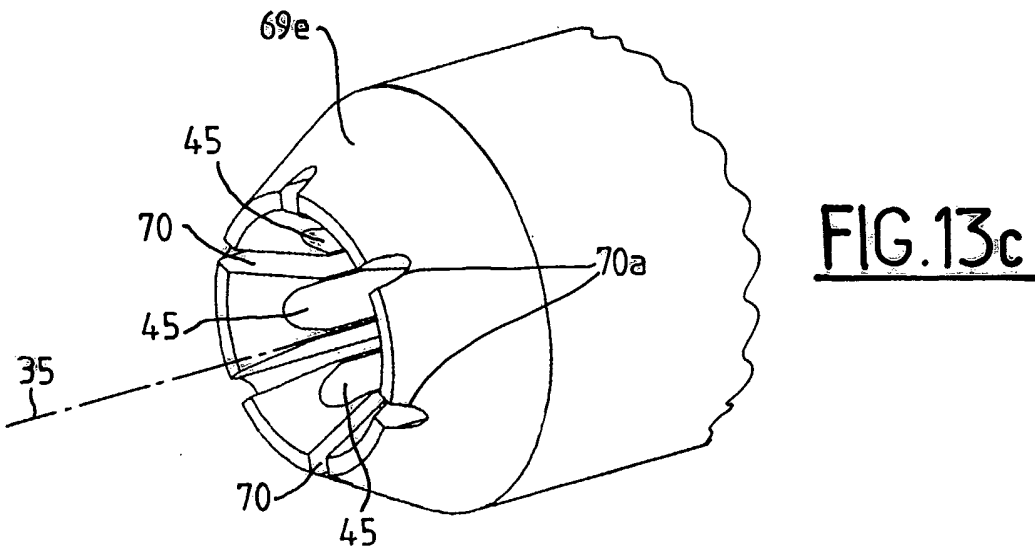
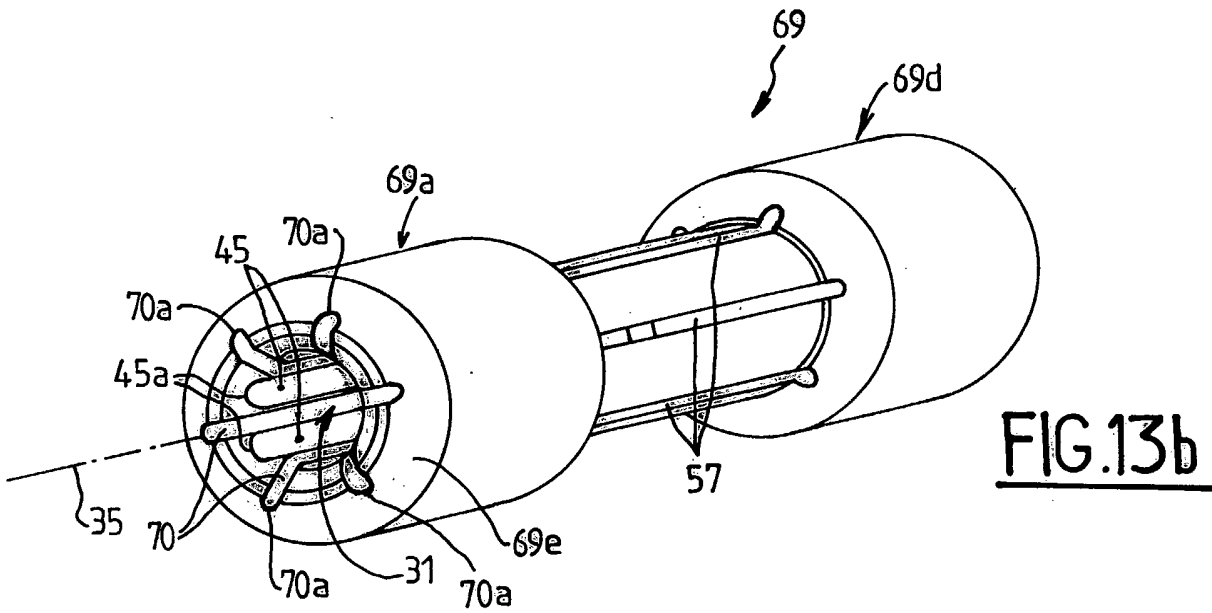
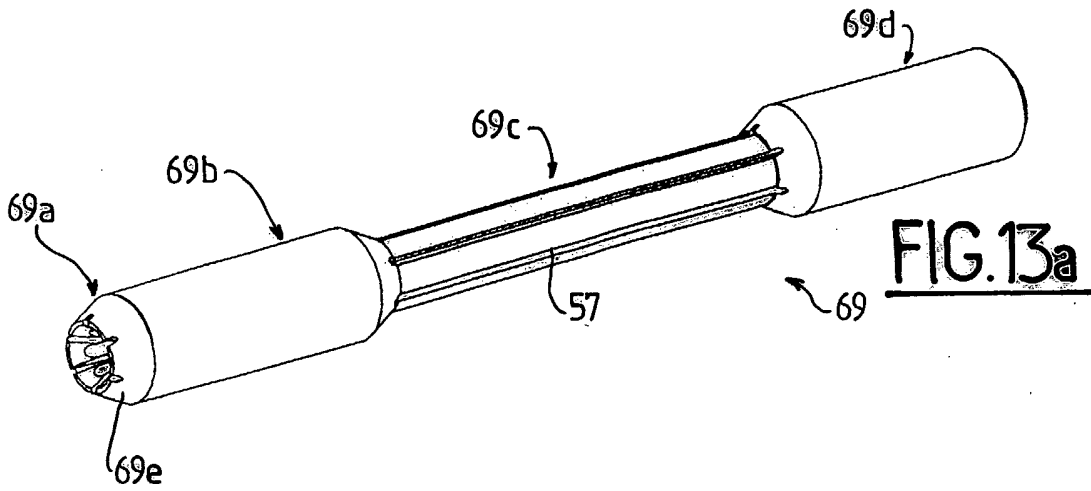

FIG. 11



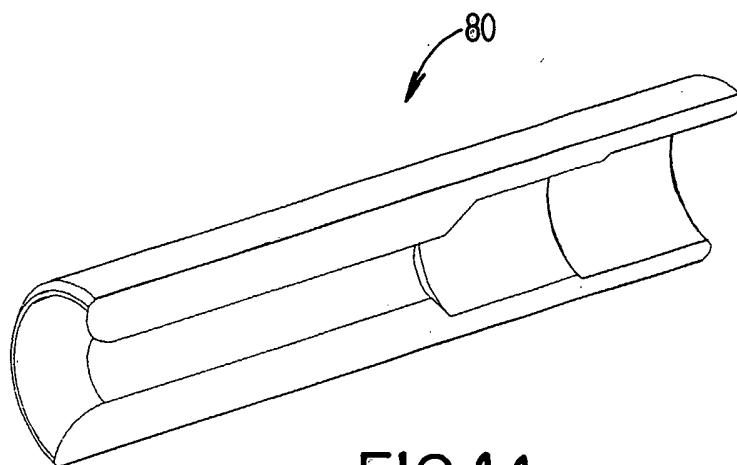

FIG. 14a

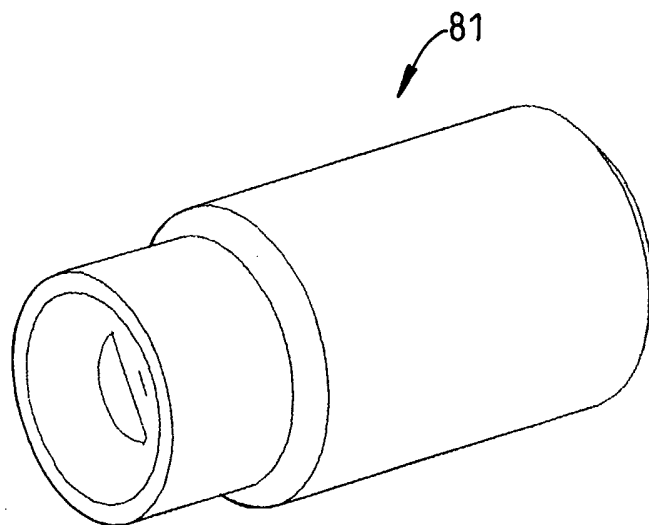

FIG. 14b

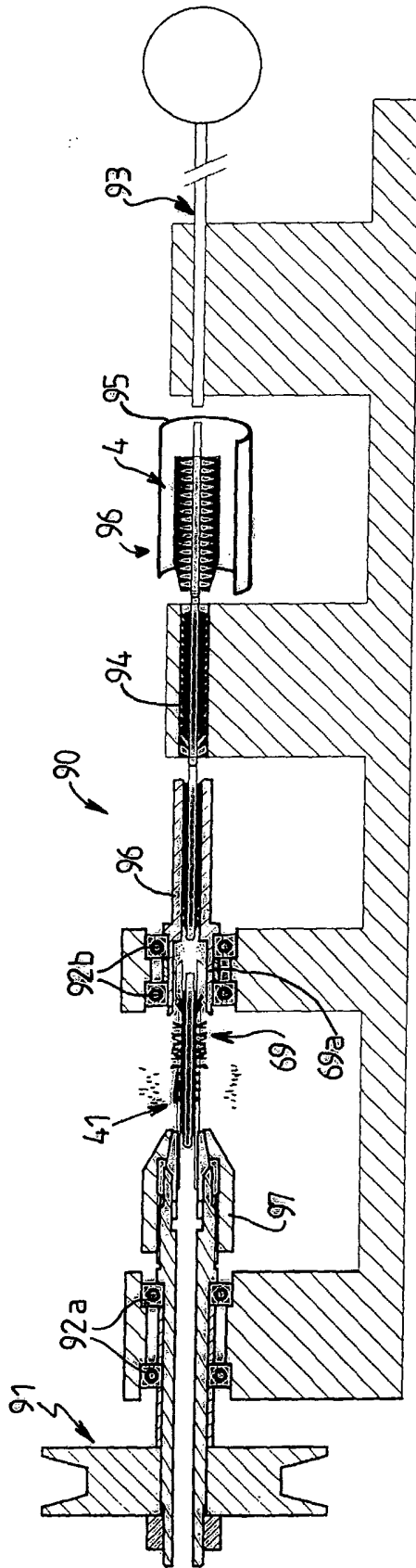

FIG. 15a

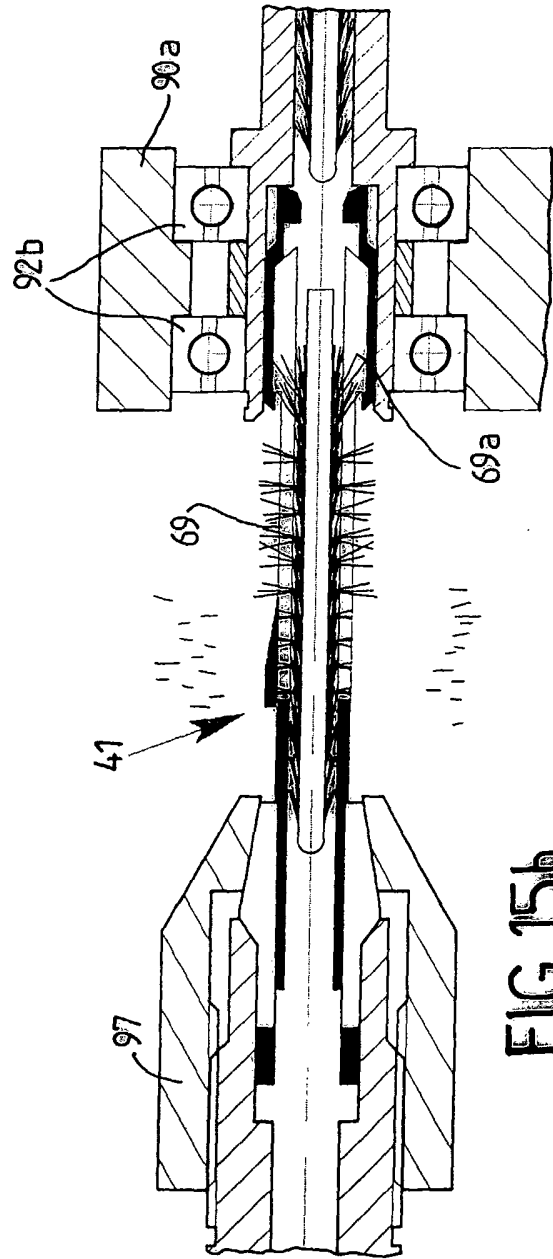

FIG. 15b

INTERNATIONAL SEARCH REPORT

International Application No
PCT/EP 03/02000

A. CLASSIFICATION OF SUBJECT MATTER
IPC 7 A46B3/18 A46B9/02 A46D1/06 A46D9/02

According to International Patent Classification (IPC) or to both national classification and IPC

B. FIELDS SEARCHED

Minimum documentation searched (classification system followed by classification symbols)
IPC 7 A46B A46D

Documentation searched other than minimum documentation to the extent that such documents are included in the fields searched

Electronic data base consulted during the international search (name of data base and, where practical, search terms used)

EPO-Internal, WPI Data, PAJ

C. DOCUMENTS CONSIDERED TO BE RELEVANT

Category °	Citation of document, with indication, where appropriate, of the relevant passages	Relevant to claim No.
A	FR 2 793 121 A (COTY SA) 10 November 2000 (2000-11-10) the whole document ---	1-31
A	US 5 020 551 A (GUERRET JEAN-LOUIS) 4 June 1991 (1991-06-04) the whole document -----	1-31

Further documents are listed in the continuation of box C.

Patent family members are listed in annex.

° Special categories of cited documents :

- *A* document defining the general state of the art which is not considered to be of particular relevance
- *E* earlier document but published on or after the international filing date
- *L* document which may throw doubts on priority claim(s) or which is cited to establish the publication date of another citation or other special reason (as specified)
- *O* document referring to an oral disclosure, use, exhibition or other means
- *P* document published prior to the international filing date but later than the priority date claimed

- *T* later document published after the international filing date or priority date and not in conflict with the application but cited to understand the principle or theory underlying the invention
- *X* document of particular relevance; the claimed invention cannot be considered novel or cannot be considered to involve an inventive step when the document is taken alone
- *Y* document of particular relevance; the claimed invention cannot be considered to involve an inventive step when the document is combined with one or more other such documents, such combination being obvious to a person skilled in the art.
- *&* document member of the same patent family

Date of the actual completion of the international search 3 April 2003	Date of mailing of the international search report 10/04/2003
Name and mailing address of the ISA European Patent Office, P.B. 5818 Patentlaan 2 NL - 2280 HV Rijswijk Tel. (+31-70) 340-2040, Tx. 31 651 epo nl, Fax: (+31-70) 340-3016	Authorized officer Neiller, F

INTERNATIONAL SEARCH REPORT

Information on patent family members

International Application No

PCT/EP 03/02000

Patent document cited in search report		Publication date	Patent family member(s)	Publication date
FR 2793121	A	10-11-2000	US 6289902 B1	18-09-2001
			FR 2793121 A1	10-11-2000
			AU 6224599 A	21-11-2000
			DE 19963600 A1	09-11-2000
			EP 1050236 A1	08-11-2000
			WO 0067611 A1	16-11-2000
			US 2002007837 A1	24-01-2002

US 5020551	A	04-06-1991	FR 2637471 A1	13-04-1990
			CA 1331682 A1	30-08-1994
			DE 3933990 A1	19-04-1990
			ES 2017155 A6	01-01-1991
			GB 2225225 A ,B	30-05-1990
			IT 1238792 B	03-09-1993
			JP 2164308 A	25-06-1990
			JP 2821917 B2	05-11-1998
			US 5063947 A	12-11-1991
