

(No Model.)

2 Sheets—Sheet 1.

A. W. ZIMMERMAN.

CAR DOOR.

No. 281,170.

Patented July 10, 1883.

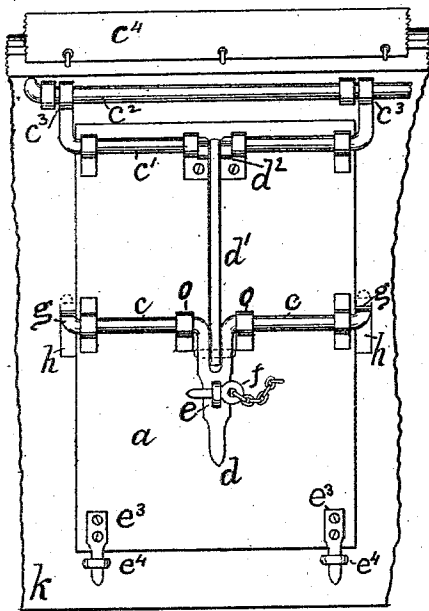

Fig. 1.

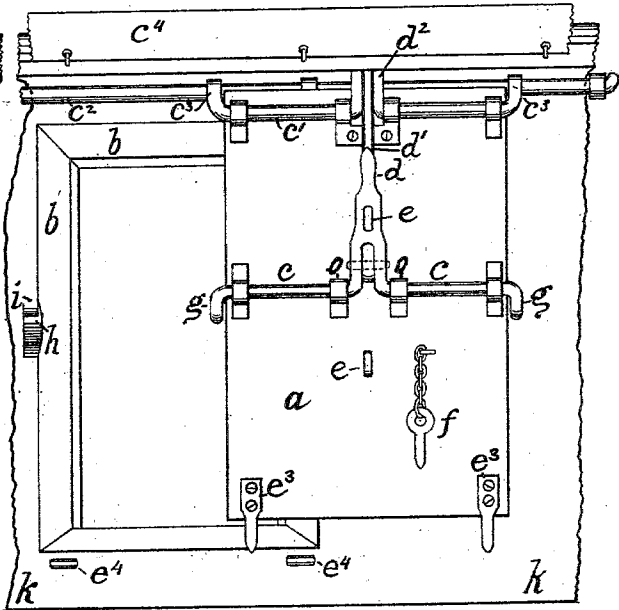

Fig. 2.

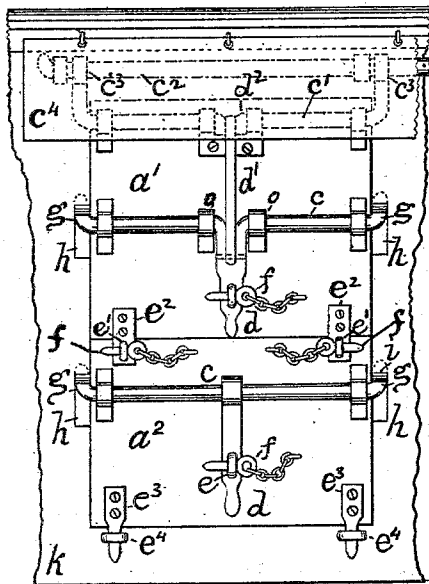

Fig. 3.

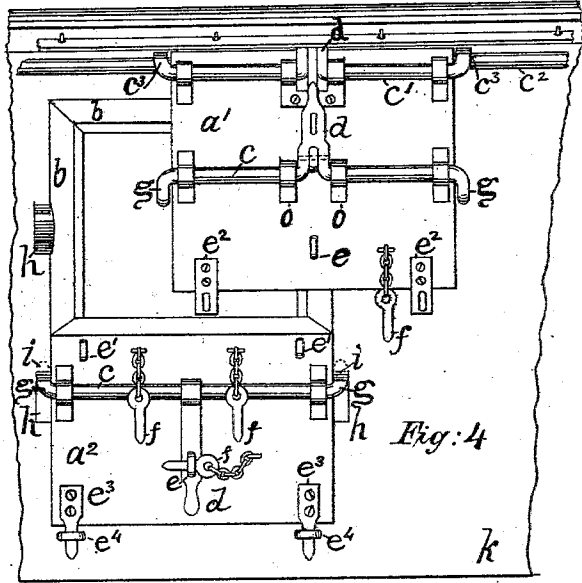

Fig. 4.

Witnesses;

Owille C. Rorabaugh
John H. Byam

Inventor.

Arnold W. Zimmerman
per Wm Zimmerman

Attorney.

(No Model.)

2 Sheets—Sheet 2.

A. W. ZIMMERMAN.

CAR DOOR.

No. 281,170.

Patented July 10, 1883.

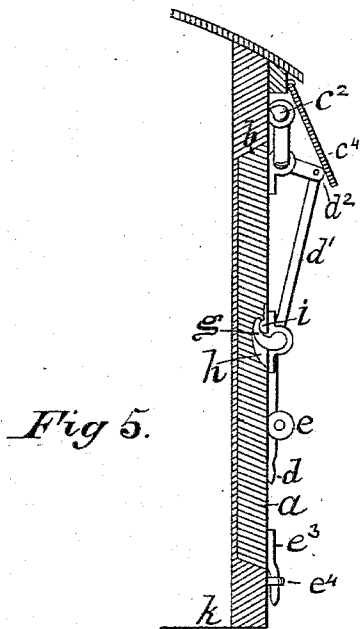

Fig 5.

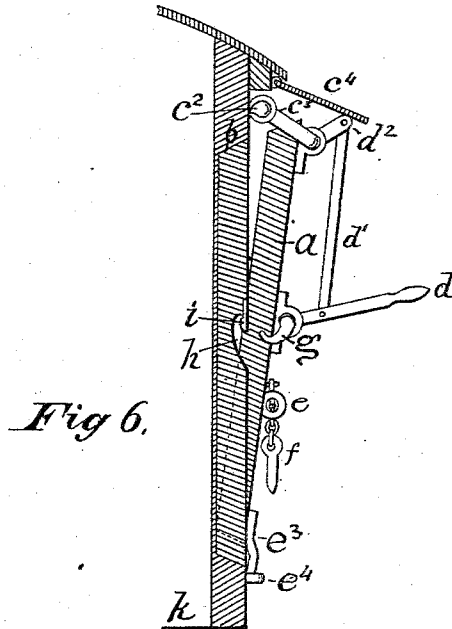

Fig 6.

Witnesses:

Orville C. Korabaugh
H. Decker

Inventor

Arnold W. Zimmerman
per *Arnold W. Zimmerman*
Attorney.

UNITED STATES PATENT OFFICE.

ARNOLD W. ZIMMERMAN, OF CHICAGO, ILLINOIS.

CAR-DOOR.

SPECIFICATION forming part of Letters Patent No. 281,170, dated July 10, 1883.

Application filed April 9, 1883. (No model.)

To all whom it may concern:

Be it known that I, ARNOLD W. ZIMMERMAN, of Chicago, in the county of Cook and State of Illinois, have invented certain new and useful Improvements in Car and Grain-Car Doors; and I hereby declare the following to be a full, clear, and exact description thereof, which will enable others skilled in the art to which my invention relates to make and use the same, reference being had to the accompanying drawings, forming a part hereof, and in which—

Figure 1 represents a side view of my improved car-door with its attachments, the door being closed and fastened, the side of the car which is shown broken away being beyond the fastenings. Fig. 2 represents the same partly open. Fig. 3 represents a door as shown in Fig. 1 changed into a grain-car door. In the former the guard or roof c^4 is shown raised to show the hanging of the door. In the latter the guard is down, and the hanging of the door is shown dotted in its outlines. Fig. 4 represents the same as shown in Fig. 3, with the upper part of the door partly open, while the lower is left in position when the car is used as a grain-car. Fig. 5 shows a transverse sectional view of a car-door of my construction in place and fastened. Fig. 6 shows the same in position at its lower end and its upper end partly thrown out on its hangings.

Like letters of reference indicate like parts.

In the drawings, k represents the side of a freight or grain car, and a a door, of which the edges are beveled, so as to fit into the correspondingly-beveled sides or door-frame b . Below the sill of the door are eyebolts or catches e^1 , into which slip bolts e^2 , fixed to the door, and so adjusted that when the door is closed the point of the conical part of the bolt has passed through the eyebolt; and to the upper end of the door is attached a rod, c^1 , which may be formed into a lever, d^2 , at its center, or have a piece attached to it and placed about at right angles with the vertical part thereof from the eye e^3 , so as to answer the same purpose. After the rod c^1 has passed beyond the vertical edges of the door a , it is turned upward parallel with said edges and formed into a hanger-hook or eye, e^4 . Said eyes slide on a rod, c^2 , firmly held to the side of the car, and

so as to allow the eye e^3 to slide longitudinally on the rod c^2 . To the lever d^2 is attached a connecting-rod, d' , connecting the levers d^2 and d . The lever d is shown as forming an extended part of a crank formed in the shaft e , but the shaft e , extending beyond the bearing o , forms a part of another invention, for which another application will be made. The lever d may have but one bearing, o , and the rod d' be attached to it on its side. e is a staple or bolt, to which the lever d may be locked. Above the rod c^2 is attached a hinged guard, c^4 , to protect said rod and all parts connected with it from the weather, as shown in Figs. 5 and 6.

To make a grain-car door, the door a shown in Figs. 1 and 2 is cut in two at a suitable height from the sill, and then the two parts a' and a^2 are united with a plate, e^2 , attached to the upper part, so as to overlap the lower, through which passes a staple or eyebolt, e , and through which is passed a bolt, f . When thus constructed, the upper half, a' , of the door may be released from the lower part and opened, the lower part being held by the bolts and eyes e^3 and fastened above by any suitable device, but preferably by my improved fastener, as shown, and which consists of a hook or spur, i , attached to and flush with the side of the car, and a recess, h , into which works the eccentric hook g on the shaft e . This last-described part will be more fully explained in the other application already referred to. When thus constructed, a car-door may be made to fit upon the outer side of the car, or it may be made to fit into a recess, as here shown, and preferably beveled, except the upper edge, which must be beveled, when the door is sunk into the frame, to make a tight fit.

The operation of my improved device is as follows, viz: The door is suspended and slides freely on the rod c^2 by the eyes or hangers e^4 . To close the door, place it over the opening. Then the lever d is raised, which, by means of the rod d' , turns the right-angled crank d^2 of the shaft e , and thus the door is raised, and at the same time thrown outward. It is then pushed inward at its lower end until the bolts e^2 enter the eyes e^1 , after which the lever is released and the door, by its own weight, falls almost wholly into place at its lower end, and

is then finally driven home by depressing the lever d , which, by means of the lever d^2 , throws the upper part of the door fully into its place, and is there held by it and the parts $e^3 e^4$, after
 5 which the lever d may be locked to the door or otherwise fastened. To open the door, raise the lever d . This will raise the door, and at the same time throw out its upper end until the bolts e^3 are released, after which the lower part
 10 of the door will swing out; then drop the lever and push the door along the rail e^2 .

The practical advantages of a sliding over a hinged swinging car-door are well known; but the operating mechanism of such doors has
 15 never heretofore been so made that such a door might at the same time move vertically to and from the opening, or that the door could enter a frame, as here shown, and at the same time be locked or closed.

I am aware that it is not new to hang a car-door on an inside sliding track by hangers, to which the door is hinged, and which is held in place by the hangers and the weight of the load pressing against the door. I do not claim
 20 such construction.

What I claim as new is—

1. In combination with the rod c^2 , a sliding door, a , provided with the rod c' , hangers c^3 , levers d^2 and d , and rod d' , constructed to operate upon said rod, substantially as specified.
 30

2. In combination with the rod c^2 and parts e^3 , e^4 , c' , d^2 , and c^3 , a sliding door constructed to open and close, substantially as specified.

3. In combination with a sliding car-door, a , constructed to close and open from a frame, b , and provided with hangers c^3 , the rods $c^2 c'$, lever d , and connecting mechanism, to operate substantially as specified.
 35

4. A sliding car-door consisting of the parts
 40 $a' a^2$, separably connected, and provided with

fastening devices at its lower end, and constructed to close into and open from a frame, b , by means of a suspension-rod, c^2 , and hangers c^3 , levers d^2 and d , and mechanism to connectedly operate said parts, substantially as
 45 specified.

5. In combination with the doors $a' a^2$, the rod c , provided with hook g and lever d , hooks i , straps e^2 , and catch e^4 , substantially as specified.
 50

6. The sliding door a , provided with fasteners $e^3 e^4$, and rod c' , with lever d^2 and hanger c^3 , in combination with the rod c^2 and guard c^4 , substantially as specified.

7. In combination with a sliding car-door, a , constructed to close into and open from a frame, b , and provided with hangers c^3 , the rod c^2 , and guard c^4 .
 55

8. An outside sliding car-door hung and constructed to operate from a suspension-rod, and provided with fasteners at its lower end, and mechanism to operate its hangers, whereby said door operates radially to said rod, and so that it may open and close vertically to its frame.
 60

9. A sliding car-door hung and constructed to operate from a suspension-rod, and mechanism to operate its hangers, whereby said door operates radially to said rod, and so that it may open and close vertically to its frame.
 65

10. A sliding car-door formed of two parts separably united, hung and constructed to operate from a suspension-rod, and mechanism to operate its hangers, whereby said door operates radially to said rod, and so that it may open
 70 and close vertically to its frame.

ARNOLD W. ZIMMERMAN.

Witnesses:

WM. ZIMMERMAN,
 ORVILLE C. RORABAUGH.