

Aug. 3, 1965

S. MELENCHUK

3,198,485

TURBINE BLADE LOCK

Filed Sept. 26, 1963

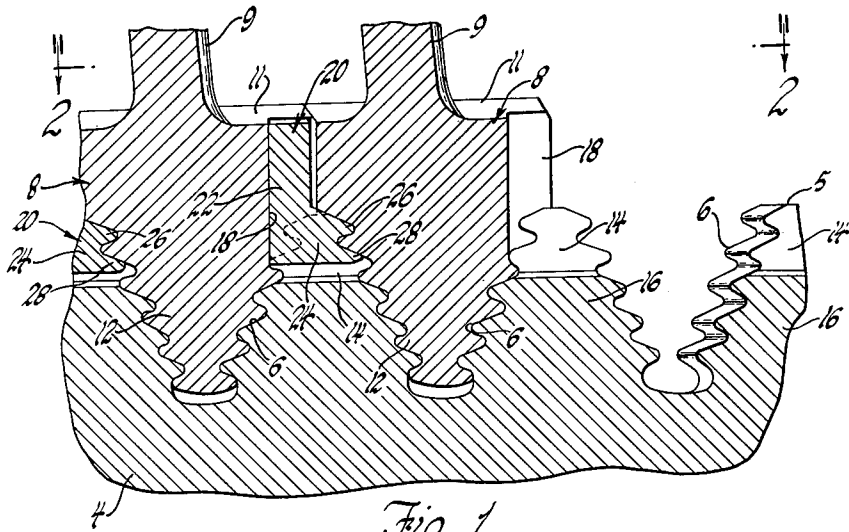

Fig. 1

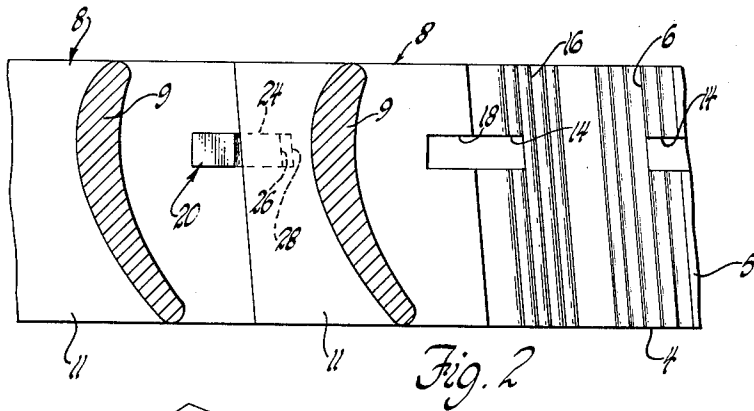

Fig. 2

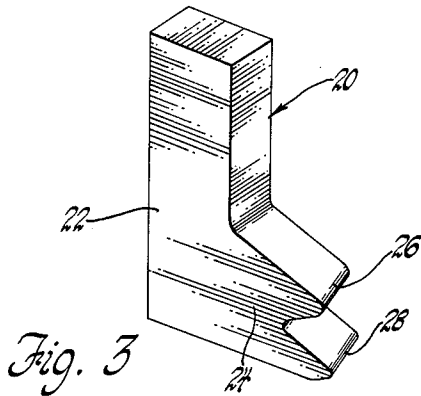

Fig. 3

INVENTOR.  
*Samuel Melenchuk*  
BY  
*Paul Fitzpatrick*  
ATTORNEY

1

3,198,485

**TURBINE BLADE LOCK**

Samuel Melenchuk, Indianapolis, Ind., assignor to General Motors Corporation, Detroit, Mich., a corporation of Delaware

Filed Sept. 26, 1963, Ser. No. 311,865

1 Claim. (Cl. 253-77)

My invention relates to rotors of turbines and analogous machines, and particularly to improved means for locking aerodynamic blades in the slots in which they are mounted in the rotor of a turbomachine.

Many compressors and turbines are of the structural type in which the wheel has blade slots extending transversely of the rim of the wheel, or generally parallel to the axis of the wheel, and in which these slots are serrated and the blades have roots which are serrated complementarily to the wheel serrations. In such a structure, the blades are mounted on the wheel by sliding the blade roots into the slots of the wheel. The assembly is completed by some device which holds the blades against sliding in the slots. Many structures for this purpose have been proposed. The one which I have devised is characterized by simplicity, ease of installation, very light weight, and a minimum of interference with the structural strength of the turbine rotor.

The nature of the invention and the advantages thereof will be clear to those skilled in the art from the succeeding detailed description of the preferred embodiment of the invention and the accompanying drawings thereof.

FIGURE 1 is a partial sectional view of a turbine or compressor rotor wheel taken in a plane transverse to the axis of the wheel.

FIGURE 2 is a plan view of FIGURE 1 with parts cut away, taken on the plane indicated by the line 2-2 in FIGURE 1.

FIGURE 3 is an axonometric view of a turbine blade lock.

FIGURES 1 and 2 show a portion of a rotor structure which, apart from the blade lock structure of my invention, may be regarded as known or conventional. The wheel 4 has at its rim or periphery 5 a ring of blade slots 6 formed with multiple dovetails or serrations or, in other words, what is commonly known as a fir-tree blade slot. These slots, as seen most clearly in FIGURE 2, extend across the rim of the wheel. A turbine blade 8 is mounted in each slot. Two such blades are illustrated. Each blade 8 comprises an airfoil portion 9, a platform 11, and a root 12. The root is multiply serrated so that it is complementary to the serrations in the wheel. The platforms overlie the outer surface of the rotor and are approximately in contact so that the outer surface of the platforms defines a more or less smooth boundary for the flow path through the turbine.

Proceeding now to the blade locking structure of my invention, it will be noted that the rim of the rotor bears a notch 14 which cuts into the upper portions of each of the projections 16 of the rotor between the blade slots 6. The margin of the platform of each blade overlies approximately half of the upper part of projection 16 and notch 14. A kerf 18 extends radially through one edge of the platform 11 and a small part of the outer portion of the root 12. The kerf 18 of each blade aligns with the notch 14 when the blade is in position on the rotor.

2

The remaining part of the locking structure is a blade-locking key or key plate 20 which is received in the kerf 18 and notch 14. The form of a typical key plate is most clearly depicted in FIGURE 3. It may be a small sheet metal stamping, or may be sawed from an extrusion of suitable cross-section. The key 20 comprises a stem 22 which is radially disposed, lying within the kerf 18, and a lug 24 extending laterally from the inner end of the key. The lug 24 has two projections or serrations 26 and 28 which are of the same outline as the serrations of the blade slots so as to mate with and lie under the two outermost serrations of the blade root 12. It will be noted that the key is extremely simple and of light weight, and that the slot and kerf which receive it are in positions of low stress in the wheel and blade, respectively. The key is positively retained by one blade root and positively interlocks the next blade root with the rim of the rotor so that the blade cannot slide out of the slot.

The mode of assembly will be apparent to those skilled in the art, but may be stated briefly. Starting with any given blade 11, it is slid into its slot and the key 20 adjacent to it to the right (as shown in FIGURES 1 and 2) is dropped into place in the kerf in the blade root and the notch in the wheel. The next blade is then slid into position in its slot and, as will be obvious, holds the key in position. Continuing around the wheel, the key is inserted in each blade and the next blade is inserted to retain the key until the last blade is put in, which cannot be retained in this manner. The final blade is retained by any other suitable means, the simplest and preferred being a radial pin extending through a hole in the blade platform into the wheel rim between the blade root grooves, and secured in position by staking the metal of the blade platform (not illustrated). While the scale of the structure will vary with the size of turbine, it will be apparent that the key 20 is relatively small compared to the blades. In the particular installation shown on the patent drawings, the overall length of the key is only  $\frac{3}{32}$  of an inch and its thickness about  $\frac{1}{16}$  inch.

The detailed description of the preferred embodiment of the invention for the purpose of explaining the principles thereof is not to be construed as limiting or restricting the invention, since many modifications may be made by the exercise of skill in the art within the scope of the invention.

I claim:

- A bladed rotor wheel assembly for a turbine or the like comprising, in combination,
- a wheel having a rim with blade slots extending transversely of the rim, the rim portion bounding the slots having multiple serrations,
- blades having roots with multiple serrations slidably insertable into the slots and having the blade root serrations interlock with the serrations on the wheel rim,
- each blade having a portion radially outwardly of the rim overlying the blade root,
- a kerf in said portion and in the radially outer portion of one lateral face of the blade root extending radially and circumferentially of the wheel,
- a notch in the wheel extending circumferentially and intersecting two serrations of the rim portion bounding the blade slots,

3

the said kerfs being aligned with the notch when the blades are installed, and

a blade retaining key having a stem adapted to lie in the said kerf and a lug extending from the stem into the said notch,

the lug having two projections conforming to and extending under two of the serrations of the root of the adjacent blade,

so that the adjacent blade root holds the key in place radially of the wheel and the key holds the first-mentioned blade in place axially of the wheel.

4

## References Cited by the Examiner

## UNITED STATES PATENTS

2,867,408 1/59 Kolb et al. ----- 253—77

## FOREIGN PATENTS

671,960 5/52 Great Britain.

779,059 7/57 Great Britain.

313,027 4/56 Switzerland.

5

10

KARL J. ALBRECHT, *Primary Examiner.*

JOSEPH H. BRANSON, JR., *Examiner.*