

WILSON & FLATHER.  
Breech-Loading Fire-Arm.

Patented Aug. 15, 1865.

No. 49,463.

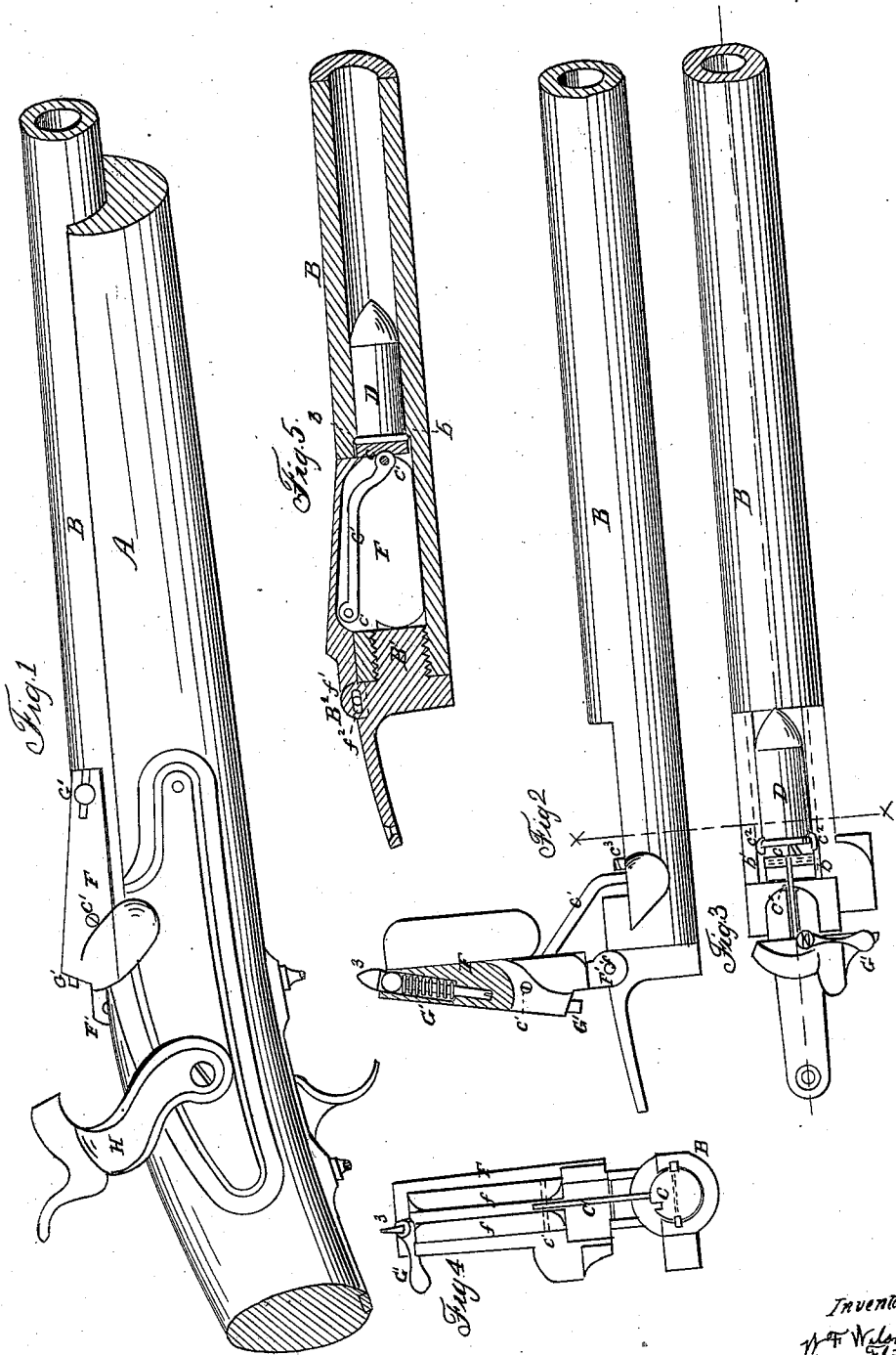

Witnesses:

C. D. Smith  
Atty: C. H. ...

Inventors:  
W. Wilson  
Henry Flather  
By Attorney

# UNITED STATES PATENT OFFICE.

W. F. WILSON AND HENRY FLATHER, OF BRIDESBURG, PENNSYLVANIA.

## IMPROVEMENT IN BREECH-LOADING FIRE-ARMS.

Specification forming part of Letters Patent No. 49,463, dated August 15, 1865.

To all whom it may concern:

Be it known that we, W. F. WILSON and HENRY FLATHER, both of Bridesburg, in the county of Philadelphia and State of Pennsylvania, have invented certain new and useful Improvements in Fire-Arms; and we do hereby declare the following to be a full and exact description of the same, reference being had to the accompanying drawings, making part of this specification, in which—

Figure 1 is a side elevation of a common musket embodying our invention. Fig. 2 is a detached view of the barrel, illustrating the construction of the movable breech-piece and the method of applying the same to the ordinary muzzle-loading fire-arms. Fig. 3 is a plan of the parts represented in Fig. 2, and also illustrates the cartridge in the position which it first occupies on being inserted. Fig. 4 is a section in the line *x x*, Figs. 2 and 3, looking from the front. Fig. 5 is a vertical longitudinal section on the line *y y*, Fig. 3.

Similar letters of reference indicate corresponding parts in the several figures.

One of the important features of our invention consists in a new and more perfect method of converting common muzzle-loading guns into breech-loaders. Another object is to provide novel and improved devices for advancing the cartridge to its firing position within the bore, receiving and sustaining the recoil, and extracting the shell of the cartridge. A further object is to adapt the exploding-pin to lock the breech-block in position for firing, and thus render unnecessary the employment of a separate bolt or other locking device.

To enable others skilled in the art to which our invention appertains to fully understand and use the same, we will proceed to describe the manner of carrying it into effect.

In the drawings, A B represent the present Springfield musket, having all its usual appurtenances with the exception of the cone, and converted into a breech-loading gun by our method, which is as follows:

We bore out the barrel immediately in front of the breech-pin B' to a sufficient extent to accommodate the cartridge D and the advancing-piston C when placed one behind the other, as shown in Fig. 3. Next we cut away a portion of the barrel, as at E, Fig. 2, to allow the breech-

piece F to be turned down into the barrel behind the cartridge D and piston C.

The boring of the rear end of the barrel is necessary in order to admit of the use of flanged cartridges and to provide a shoulder, *b*, for such flanges.

As a means of attachment for the hinge or pivot F', upon which the breech-piece F turns, we provide a boss or projection, B<sup>2</sup>, which is secured to the breech-pin B' by brazing or otherwise. After the boring operation the breech-pin B' is reinserted.

The piston C is attached by a pivot, *c*, to the link C', which is pivoted to the breech-piece F by a screw or pin, *c'*, so that the piston C will be advanced when the breech is closed and retracted when it is opened, the link C' working in a slot, *f*, in the breech-piece for the purpose of allowing the piston C to occupy a position directly in front of that part of the breech-piece which extends down into the bore in the closed condition of the parts. Being thus inserted between the breech-pin B' and piston C, the breech-pin F constitutes for the piston C a bearing of great strength, to receive the force of the recoil upon the explosion of the charge.

It is desirable that the force of the explosion should be transmitted in a direct line, or at right angles from that part of the breech-piece F within the bore, to the breech-plug, and to this end we make the axis of vibration of the breech-piece F movable by fitting the pin *f'* in a slot, *f*<sup>2</sup>. This method of hinging the breech-piece allows the rear face of that part of it which enters the bore to describe a curve on a movable center in its vibration, thus avoiding the parts which would intercept it if moving in the arc of a circle, and setting squarely against the breech-pin when the breech-piece is in its closed position.

*c*<sup>2</sup> *c*<sup>2</sup> are guides or projections on the piston C, moving in grooves formed one on either side of the bore, as indicated by dotted lines in Fig. 3. In addition to their functions of guiding the piston C in proper position, the projections *c*<sup>2</sup> serve as ejectors of the empty cartridge-shells, for which purpose they are notched to receive the flange of the cartridge. The opening in the barrel for the breech-piece will admit of the insertion of the flange of the cartridge at but one point, which is recessed, as

seen at  $b' b'$ , said opening being at other points smaller than the diameter of the bore and base of the cartridge. The piston C, when retracted, occupies so much of the recesses  $b' b'$  that only sufficient room will be left to accommodate the cartridge, and directly beneath the point where the flange of the cartridge must necessarily enter will be the notches in the projections  $c^2 c^2$ , which must invariably receive the flange of the cartridge when the latter is placed in the gun. After being thus inserted the cartridge will slide freely to the pressure of the piston C until its flange comes in contact with the shoulders  $b b$  in the bore, when the parts occupy the relative positions represented in Fig. 5. On the opening of the breech-piece the notched projections, acting upon the flange of the cartridge, retract the shell to the position which it occupies when first inserted, and from which it may be readily shaken or otherwise removed from the bore.

G represents a pin or bolt, which is impelled forward by the hammer H against the fulminate base of the cartridge, to produce the explosion thereof. The pin G is adapted to slide longitudinally within the breech-piece F, and is provided with a spring,  $G'$ , which acts upon the pin G to project its forward end,  $g$ , beyond the front of the breech-piece F. The end  $g$  is beveled, so as to cause the pin to yield backward flash with the front of the breech-piece F, to pass the upper side of the barrel during the closing of the breech-piece, after which the pin G resumes its advanced position, projecting beneath the upper side of the barrel and resting within a slot,  $c^3$ , in the piston C. In this position the pin G locks the

breech-piece F, and may be driven forward against the base of the cartridge by the hammer H. The pin G is retracted by means of a knob or finger-piece,  $G'$ , when the breech-piece is to be turned to its open position. The movement of the pin G may be limited by a screw passing through the slot  $g'$ .

In using a gun of the above construction the cartridge can be conveniently inserted when the piece is at "present arms," with the muzzle up, so that it can be used by infantry in the ranks without danger.

Having thus described our invention, the following is what we claim as new herein and desire to secure by Letters Patent:

1. The hinged breech-piece F, having a movable axis of vibration in being opened and closed, in combination with the piston C, which moves in line with the bore, operates against the base of the cartridge, and is locked by said breech-piece, substantially as described.
2. In combination with the piston C, having projections  $c^2$ , for guiding it by sliding in grooves, as described, the link  $C'$ , caused to advance and retract the piston in line with the barrel during the opening and closing movements of the breech-piece F, and entering the grooves  $f$  when the breech-piece is closed, for the purpose explained.
3. The exploding-pin G, having a knob or finger-piece,  $G'$ , when used for locking the breech-piece, as set forth.

W. F. WILSON.  
HENRY FLATHER.

Witnesses:

WASHINGTON SPANGLER,  
WM. M. SMIRER.