

N. C. WALTERTHUM.  
VALVE.  
APPLICATION FILED OCT. 19, 1908.

914,902.

Patented Mar. 9, 1909.

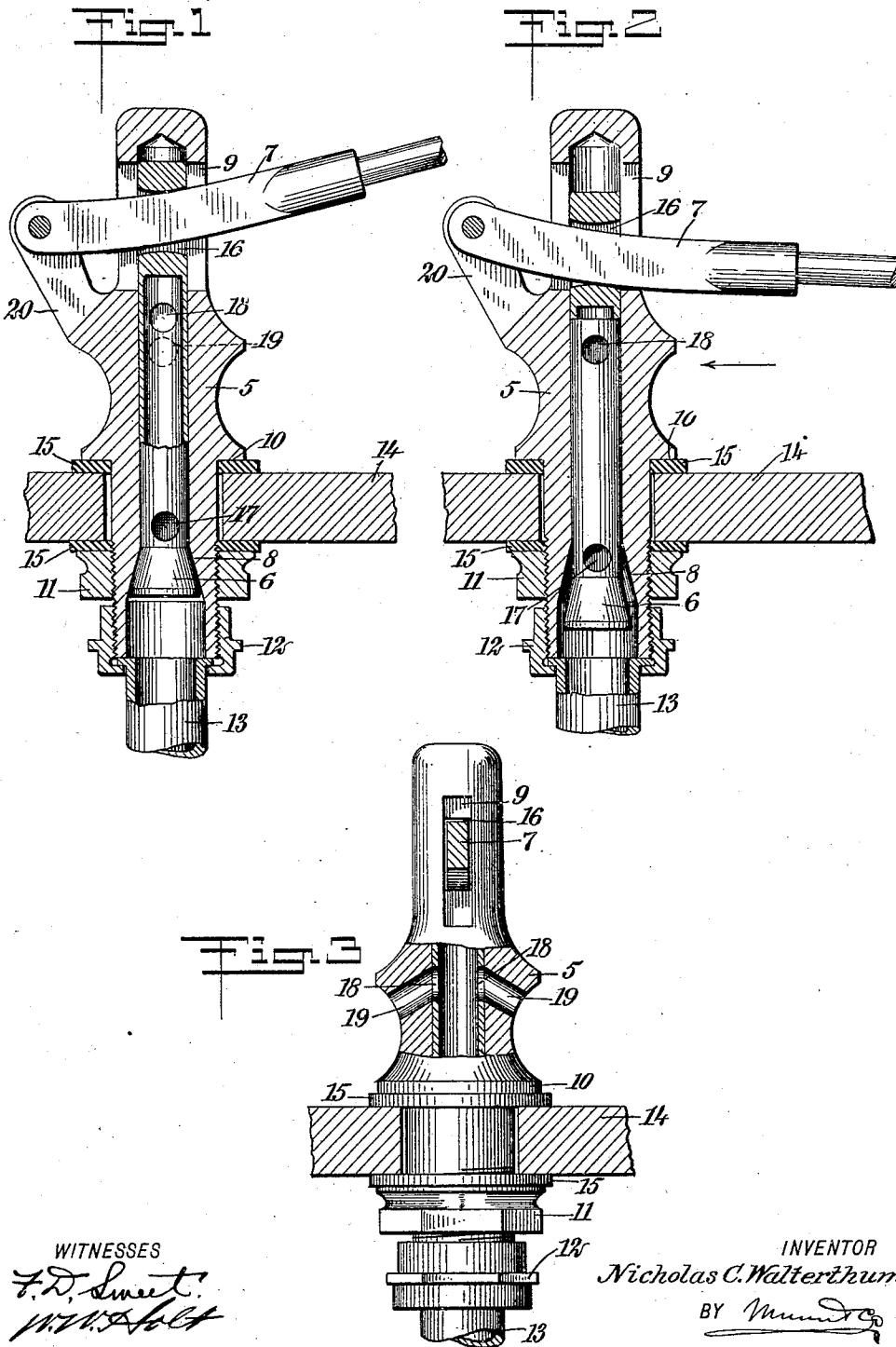

WITNESSES  
F. D. Sweet  
W. H. Holt

INVENTOR  
Nicholas C. Waltherthum  
BY *Mumford*  
ATTORNEYS

# UNITED STATES PATENT OFFICE.

NICHOLAS C. WALTERTHUM, OF JERSEY CITY, NEW JERSEY.

VALVE.

No. 914,902.

Specification of Letters Patent.

Patented March 9, 1909.

Application filed October 19, 1908. Serial No. 458,449.

*To all whom it may concern:*

Be it known that I, NICHOLAS C. WALTERTHUM, a citizen of the United States, and a resident of Jersey City, in the county of Hudson and State of New Jersey, have invented a new and Improved Valve, of which the following is a full, clear, and exact description.

The invention is an improved valve for flush tanks and is designed to provide a simple effective construction for the purpose, in which gaskets or other packing in connection with the working parts is dispensed with.

To this end the invention consists of the combination of a valve casing having a longitudinal bore, an outlet opening and a slot near one end intersecting said bore, a valve having a stem of tubular construction intermediate its ends and slidable in said bore, provided with a slot of less length than the slot of the casing and in register therewith, the valve stem further provided with inlet and outlet openings respectively leading into and out of the tubular portion of the stem, and a float-controlled arm pivoted to the valve casing and passing through both the slot of the casing and the slot of the valve stem, for seating the valve and moving it from its seat and bringing the outlet opening of the valve stem in register with the outlet opening of the valve casing.

Reference is to be had to the accompanying drawings forming a part of this specification, in which similar characters of reference indicate corresponding parts in all the views.

Figure 1 is a vertical central sectional view through the preferred form of my improved valve, showing the valve in seated position; Fig. 2 is a similar sectional view showing the valve depressed and unseated; and Fig. 3 is a view of the valve looking in the direction of the arrow in Fig. 2 and partly in central vertical section.

The invention essentially consists of a valve casing 5, a valve 6 and a float-controlled arm or operating lever 7. The casing has a longitudinal bore which is enlarged or counterbored at its lower or shank end to produce a valve seat 8 of conical form, and at the opposite and upper end of the casing it has a slot 9 intersecting its bore. At the juncture of the body or upper portion of the casing and its shank a shoulder 10 is formed, and the said shank is externally threaded both for receiving a jam-nut 11 and a coup-

ling 12 for connecting it with the water supply pipe 13, the jam-nut serving to bind the flush tank 14 between it and the shoulder and form a water-tight connection by means of suitable gaskets 15.

The valve 6 is constructed with a relatively long stem, which is tubular intermediate its ends and has a transverse slot 16, above the tubular portion, of less length than the slot 9 in the casing and in register therewith. At the bottom of the tubular portion of the stem adjacent to the valve head are inlet openings 17, and similar outlet openings 18 are provided at the head of the tubular portion of the stem and are adapted to register with downwardly and outwardly-inclined outlet openings 19 in the valve casing, as shown in Fig. 3, when the valve is depressed and unseated. The float-controlled arm 7 passes through both the slot 9 of the casing and the slot 16 of the valve stem, and is pivotally connected to a bifurcated arm 20 projecting upwardly and outwardly from the casing and integral or otherwise rigid therewith.

In the operation of the valve when thus applied to the flush tank, when the tank is filled, the arm 7, under the action of the usual float, presses the valve firmly to its seat and cuts off the water supply. When the water runs out of the tank the arm 7 drops, unseating the valve and placing the inlet openings 17 in communication with the water supply, and the outlet openings 18 in register with the outlet openings 19 of the casing. The water on passing out of the openings 19 is prevented from spattering over the sides of the tank by reason of the manner in which these openings are directed. As the water rises in the tank, the float-controlled arm gradually raises the valve to its seat, completely cutting off the supply when the normal water level in the tank is reached.

Having thus described my invention, I claim as new and desire to secure by Letters Patent:

1. The combination of a valve casing having a longitudinal bore, an outlet opening and a slot near one end intersecting said bore, a valve having a stem of tubular construction intermediate its ends and slidable in said bore and provided with a slot of less length than the slot of the casing and in register therewith, said valve stem being further provided with inlet and outlet openings respectively leading into and out of the tubular portion of the stem, and a float-controlled

arm pivoted to the valve casing and extending through both the slot of the casing and the slot of the valve stem, for seating the valve and moving it from its seat and bringing the outlet opening of the valve stem in register with the outlet opening of the valve casing.

2. The combination of a valve casing having a bore and a slot intersecting the upper portion of the bore, said casing provided with an outlet opening in the side thereof below said slot, a valve having a stem slidable in the bore of the casing, with the intermediate portion of said stem of tubular form and provided with inlet and outlet openings respectively arranged at the upper and lower por-

tions thereof, a float-controlled arm passing through the slot of the casing and connected with the stem of the valve, operable when moved to extreme positions to respectively seat the valve and to unseat the valve and bring the outlet opening of the valve stem in register with the outlet opening of the valve casing.

In testimony whereof I have signed my name to this specification in the presence of two subscribing witnesses.

NICHOLAS C. WALTERTHUM.

Witnesses:

W. W. HOLT,  
JOHN P. DAVIS.