

(19) World Intellectual Property Organization
International Bureau



(43) International Publication Date
13 February 2003 (13.02.2003)

PCT

(10) International Publication Number
WO 03/012252 A1

(51) International Patent Classification⁷: **E21B 33/1295**

(21) International Application Number: PCT/US02/22993

(22) International Filing Date: 19 July 2002 (19.07.2002)

(25) Filing Language: English

(26) Publication Language: English

(30) Priority Data:
09/916,985 27 July 2001 (27.07.2001) US

(71) Applicant: **BAKER HUGHES INCORPORATED**
[US/US]; 3900 Essex Lane, Suite 1200, Suite 1200,
Houston, TX 77027 (US).

(72) Inventors: **KING, James, G.**; 801 West 31st, Houston,
TX 77018 (US). **WELCH, Edward, W., Jr.**; 1410 Eagle-
wood Valley Court, Houston, TX 77036 (US).

(81) Designated States (national): AE, AG, AL, AM, AT, AU,
AZ, BA, BB, BG, BR, BY, BZ, CA, CH, CN, CO, CR, CU,

CZ, DE, DK, DM, DZ, EC, EE, ES, FI, GB, GD, GE, GH,
GM, HR, HU, ID, IL, IN, IS, JP, KE, KG, KP, KR, KZ, LC,
LK, LR, LS, LT, LU, LV, MA, MD, MG, MK, MN, MW,
MX, MZ, NO, NZ, OM, PH, PL, PT, RO, RU, SD, SE, SG,
SI, SK, SL, TJ, TM, TN, TR, TT, TZ, UA, UG, UZ, VN,
YU, ZA, ZM, ZW.

(84) Designated States (regional): ARIPO patent (GH, GM,
KE, LS, MW, MZ, SD, SL, SZ, TZ, UG, ZM, ZW),
Eurasian patent (AM, AZ, BY, KG, KZ, MD, RU, TJ, TM),
European patent (AT, BE, BG, CH, CY, CZ, DE, DK, EE,
ES, FI, FR, GB, GR, IE, IT, LU, MC, NL, PT, SE, SK,
TR), OAPI patent (BF, BJ, CF, CG, CI, CM, GA, GN, GQ,
GW, ML, MR, NE, SN, TD, TG).

Published:
— with international search report

For two-letter codes and other abbreviations, refer to the "Guidance Notes on Codes and Abbreviations" appearing at the beginning of each regular issue of the PCT Gazette.

(54) Title: LABYRINTH LOCK SEAL FOR HYDROSTATICALLY SET PACKER

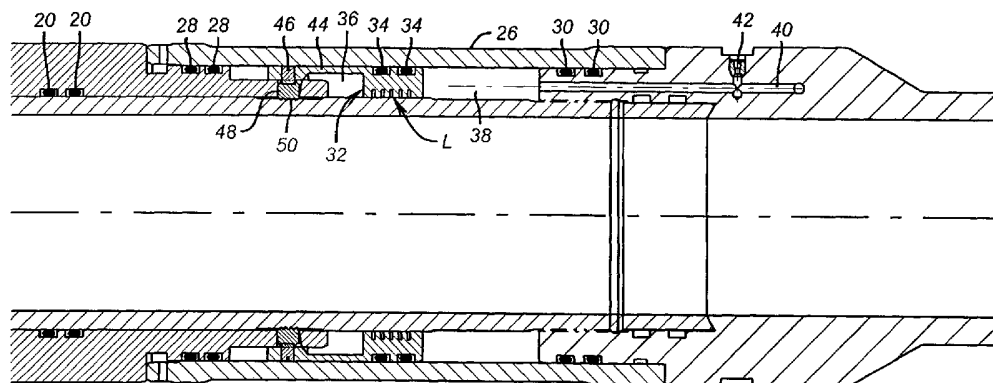

(57) Abstract: A hydrostatically set packer is disclosed. The actuating piston (18) is locked for run in by a lock sleeve (32) and lock dog (48) arrangement. When the desired depth is reached well pressure is built up to break a rupture disc (42) to allow hydrostatic pressure to act on one side of a lock sleeve. The other side of the lock sleeve is exposed to a chamber (36) under atmospheric or low pressure. Movement of the lock sleeve releases the lock dog allowing piston movement to set the packer. The lock sleeve has a labyrinth seal (L) so that seal leakage below a predetermined level will not prematurely activate the piston lock and prematurely set the packer. A variety of designs for the labyrinth are described-



WO 03/012252 A1

LABYRINTH LOCK SEAL FOR HYDROSTATICALLY SET PACKER

5 FIELD OF THE INVENTION

The field of this invention is labyrinth seal design as well as a particular application to a lock for a hydrostatically set packer.

BACKGROUND OF THE INVENTION

10 Hydrostatically set devices for subterranean wells such as packers in the past have relied on an initially locked piston. When the packer was placed at the desired depth, the locking mechanism was released, generally by pressurization of the wellbore, or an electromechanical device or system. The electromechanical devices include, but are not limited to, systems that rely on acoustic, pressure pulse, or
15 vibratory communication methods to enable the setting sequence of the packer or other downhole device. The applied wellbore pressure would break a rupture disc to expose the lock to hydrostatic pressure. In the embodiment of the electromechanical device, the device would expose the lock to hydrostatic pressure. Hydrostatic pressure, acting on one side of the lock against an atmospheric chamber on the other
20 side of the lock, allowed the lock to move. Release of the lock permits piston movement. The piston moves due to the force of hydrostatic pressure across the piston which would set the slips and compress the seal against the borehole wall or tubular, or otherwise actuate the device. A lock ring would hold the set.

A potential problem with this known design was that seal leakage could allow
25 pressure to prematurely communicate to one side of the lock so that the packer would be prematurely unlocked and consequently, hydrostatically set. Thus, an objective of the present invention is to acknowledge that seal leakage is a potential occurrence with drastic and expensive consequences and to deal with that possibility. The objective is met using a wide variety of labyrinth seals on the lock sleeve assembly.
30 Even if leakage of the seals below a predetermined level were to occur, the labyrinth seal would prevent a net force from occurring on the lock sleeve, thus preventing premature hydrostatic setting of the packer.

Labyrinth seals have been used in different tools in downhole applications. They have been used in perforating guns, as shown in U.S. Patents 4,886,126 and 5,680,905. They have been used in downhole turbo-machines, U.S. Patent 4,264,285 and in a fluid flow regulator, U. S. Patent 4,858,644. Hydraulically released locks for packers have been used in U.S. Patent 5,320,183.

U.S. Patent 5,720,349 shows the use of a labyrinth seal in an assembly of an anchor, whipstock, and a starter mill. The labyrinth seal compensates for thermal expansion of a fluid filled system to prevent setting of the anchor due to pressure that would have otherwise built up due to thermal effects. This device is focused on compensation for pressure from thermal expansion. On the other hand, U.S. Patent 5,689,905, in the context of a perforating gun, is focused on use of the labyrinth seal to prevent premature actuation of the gun due to seal leakage. Those skilled in the art will appreciate the scope of this invention from the description of the preferred embodiment, which appears below and the claims, which appear thereafter.

15

SUMMARY OF THE INVENTION

A hydrostatically set packer is disclosed. The actuating piston is locked for run in by a lock sleeve and lock dog arrangement. When the desired depth is reached well pressure is built up to break a rupture disc to allow hydrostatic pressure to act on one side of a lock sleeve. The other side of the lock sleeve is exposed to a chamber under atmospheric or low pressure. Movement of the lock sleeve releases the lock dog allowing piston movement to set the packer. The lock sleeve has a labyrinth seal so that seal leakage below a predetermined level will not prematurely activate the piston lock and prematurely set the packer. A variety of designs for the labyrinth are described.

20
25

BRIEF DESCRIPTION OF THE DRAWINGS

Figures 1a-1e are a section view of a hydrostatically set packer with the labyrinth seal on the lock sleeve for the actuating piston;

Figure 2 is a section view of the labyrinth seal shown in Fig. 1;

Figure 3 is an alternative embodiment of the labyrinth seal using a pinhole leak path;

Figure 4 is an alternative embodiment of the labyrinth seal showing the use of a flow restrictor;

Figure 5 is the preferred embodiment of the labyrinth seal, showing it externally mounted.

5

DETAILED DESCRIPTION OF THE PREFERRED EMBODIMENT

Referring to Figs. 1a-1e, the packer **P** of the invention has a top sub **10** used to secure a tubing string (not shown). The upper mandrel **12** is connected to top sub **10**. The lower mandrel **14** is connected to the upper mandrel **12** and the **bottom** sub **16** is below the lower mandrel **14**. A piston **18** is mounted around the upper mandrel **12** and lower mandrel **14** and with seal pairs **20** and **22** defines an atmospheric cavity **24**. An outer sleeve **26** is connected to bottom sub **16** at one end and extends to piston **18** at the other end. Seal pairs **28** and **30** define an annular cavity in which the lock sleeve **32** is disposed. Lock sleeve **32** has a seal pair **34** so as to create opposed sealed cavities **36** and **38** on opposed sides of lock sleeve **32**. Bottom sub **16** has a passage **40**, which is initially blocked by a rupture disc **42**. Passage **40** extends into cavity **38**.

Lock sleeve **32** has a cylindrical extension **44** with a shear pin **46** extending into piston **18**. Dog **48** is held into groove **50** by cylindrical extension **44**. Piston **18** is trapped against movement until lock sleeve **32** has moved breaking the shear pin **46** and undermining the force holding the dog **48** in the groove **50**. Since cavity **24** is at atmospheric or low pressure, the net force to piston **18** moves it up against lower slip **52**, which in turn compresses seal assembly **54** and upper slip **56** against stop **58**. A lock ring **60** holds the set position.

In operation, the packer **P** is lowered to the desired position and pressure is built up to break the rupture disc. The burst pressure of the rupture disc **42** is set higher than the anticipated hydrostatic pressure anticipated at the setting depth. Other devices for allowing selective access into passage **40** can be alternatively used. Once the rupture disc is broken, pressure builds in cavity **38**. Since cavity **36** is at or close to atmospheric pressure, the pressure buildup in cavity **38** moves the lock sleeve and the collet integral to it, up hole to break the shear pin **46** and to release dog **48** from groove **50**. Now with the lock sleeve **32** abutting the piston **18**, pressure in cavity **38** also acts on piston **18**. Since cavity **24** is at atmospheric there is little resistance to the

uphole movement of piston 18 and the packer P sets in the manner described above. This is the normal operation.

The present invention modifies the above-described design by an addition of a labyrinth seal L to the lock sleeve 32. Various embodiments are illustrated in Figs. 2-5. The embodiment of Fig. 1d is shown in greater detail in Fig. 2. Grooves 62 and 64 retain seal pair 34 (not shown in Fig. 2). The tortuous path starts with longitudinal groove 66, which leads to circular groove 68. Flow must go 180 degrees to reach another longitudinal groove (not shown) to get into circular groove 70. From there the flow must go around 180 degrees to another longitudinal groove 72 and into circular groove 74. From there the flow is circumferential to another longitudinal groove (not shown) to groove 76. Thereafter, flow goes circumferentially to longitudinal groove 78 and out into circular groove 80. Fig 5 is in essence the same design except the tortuous path is on the outside surface 82 rather than the inside surface 84. Placing the tortuous path on the outside is preferred because it simplifies the machining of the part.

In Fig. 3, grooves 62 and 64 are opposed by grooves 86 and 88 to accommodate opposed seal pairs such as 34 (shown in Fig. 1d). The leak path 90 is machined or cast into lock ring 32, depending how the part is produced. Alternatively, a commercially available restrictor, represented schematically by arrow 92 can be mounted in bore 94.

The advantage of using any of these versions or any others that allow a leak rate of a predetermined value to occur without moving the lock sleeve 32 is that premature setting will not occur due to leakage up to a predetermined rate past seals 28 or 30. But for the labyrinth seal of the present invention leakage past seal pairs 28 or 30 will force movement of lock sleeve 32 liberating piston 18 to move to set the packer P. Leakage of seals 20 or 22 will simply prevent piston 18 from moving because no pressure differential exists once cavity 24 equalizes with the downhole environment. The packer P will not set if there is leakage around seals 34, which is sufficiently severe. If that happens, hydrostatic pressure will not be able to put sufficient differential pressure on lock sleeve 32 to move it to break shear pin 46 and liberate dog 48.

Those skilled in the art will appreciate that if the hydrostatic pressure at the setting depth is too low, the packer **P** can be set with applied well pressure into passage **40** after breaking the rupture disc **42**. Dissolving plugs or other temporary barriers or valves actuated from the tool or the surface can be used in place of rupture disc **42**. The invention may be used on any downhole tool which has a hydrostatically set feature including a sleeve valve, ball valve, shifting mechanism, hole punching mechanism, pressure equalizing mechanism, tool or tool component deployment mechanism, or other hydrostatically powered mechanism

It is to be understood that this disclosure is merely illustrative of the presently preferred embodiments of the invention and that no limitations are intended other than as described in the appended claims.

We claim:

1. A downhole hydrostatically settable tool comprising:
 - a mandrel;
 - a piston mounted to said mandrel;
 - 5 a moveable component actuated by said piston;
 - a slideably mounted lock assembly, for said piston, mounted to an enclosure defined at least in part by said mandrel and selectively movable in response to exposure of one part of said lock assembly in said enclosure to downhole hydrostatic pressure;
 - 10 said lock assembly further comprising a labyrinth seal mounted to said lock assembly in said enclosure and allowing a leak flow therethrough without allowing said piston to be unlocked.

2. The tool of claim 1, wherein:
 - 15 said moveable component further comprises a gripping assembly on said mandrel selectively actuated by said piston;
 - said lock assembly comprises an interior surface closest to said mandrel and an outer surface; and
 - said labyrinth seal is disposed on said outer surface.

- 20 3. The tool of claim 1, wherein:
 - said lock assembly comprises an interior surface closest to said mandrel and an outer surface; and
 - said labyrinth seal is disposed on said interior surface.

- 25 4. The tool of claim 1, wherein:
 - said labyrinth seal comprises a plurality of circumferential grooves with adjacent grooves connected by at least one longitudinal groove, said longitudinal grooves are offset from each other as
 - 30 between adjacent circumferential grooves.

5. The tool of claim 1, wherein:
said labyrinth seal comprises a longitudinal bore extending through said lock assembly.
- 5 6. The tool of claim 1, wherein:
said labyrinth seal comprises a longitudinal bore extending through said lock assembly; and
a restrictor mounted in said bore.
- 10 7. The tool of claim 6, wherein:
said restrictor is removably mounted
8. The tool of claim 2, wherein:
said labyrinth seal comprises a plurality of circumferential
15 grooves with adjacent grooves connected by at least one longitudinal groove, said longitudinal grooves are offset from each other as between adjacent circumferential grooves.
9. The tool of claim 3, wherein:
20 said labyrinth seal comprises a plurality of circumferential grooves with adjacent grooves connected by at least one longitudinal groove, said longitudinal grooves are offset from each other as between adjacent circumferential grooves.
- 25 10. A labyrinth seal for a downhole tool component, comprising:
a plurality of circumferential grooves with adjacent grooves connected by at least one longitudinal groove, said longitudinal grooves are offset from each other as between adjacent circumferential grooves.

30

11. The labyrinth seal of claim 10, wherein:

said downhole component had an annular shape with an inside and an outside surface and said grooves are disposed on said outside surface.

5

12. The labyrinth seal of claim 10, wherein:

said downhole component had an annular shape with an inside and an outside surface and said grooves are disposed on said inside surface.

10

13. A labyrinth seal for a downhole tool component, comprising:

a longitudinal bore extending through said downhole component.

15 14. The labyrinth seal of claim 13, further comprising:

a flow restrictor mounted in said bore.

15. The labyrinth seal of claim 14, wherein:

said flow restrictor is removably mounted.

20

16. The anchor or packer of claim 1, further comprising:

a sealing assembly selectively actuated by said piston.

17. The anchor or packer of claim 16, further comprising:

25 a ratchet lock to hold said slips and said sealing assembly outwardly from said mandrel after said piston has moved.

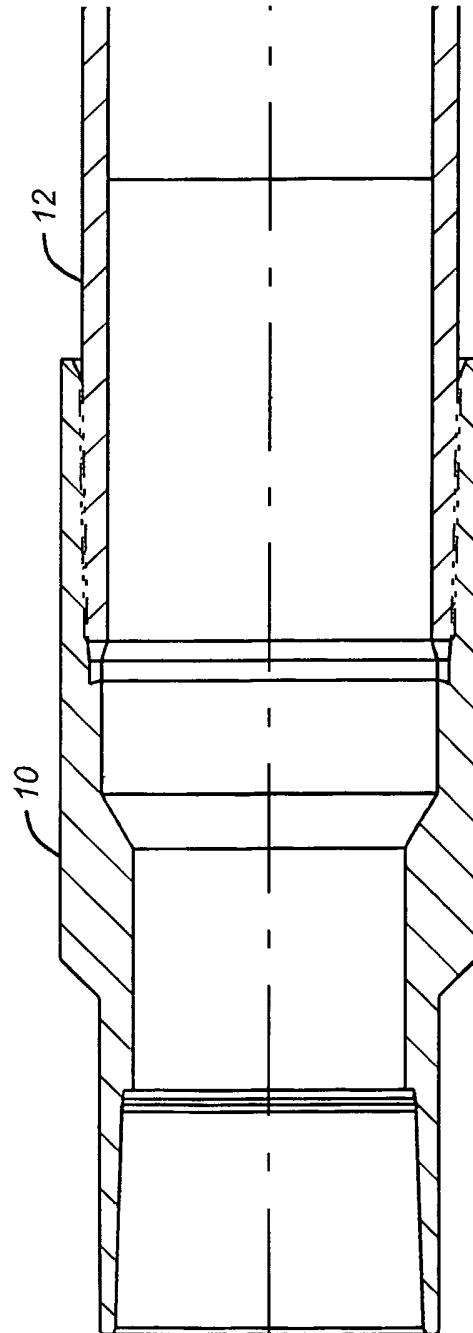

FIG. 1a

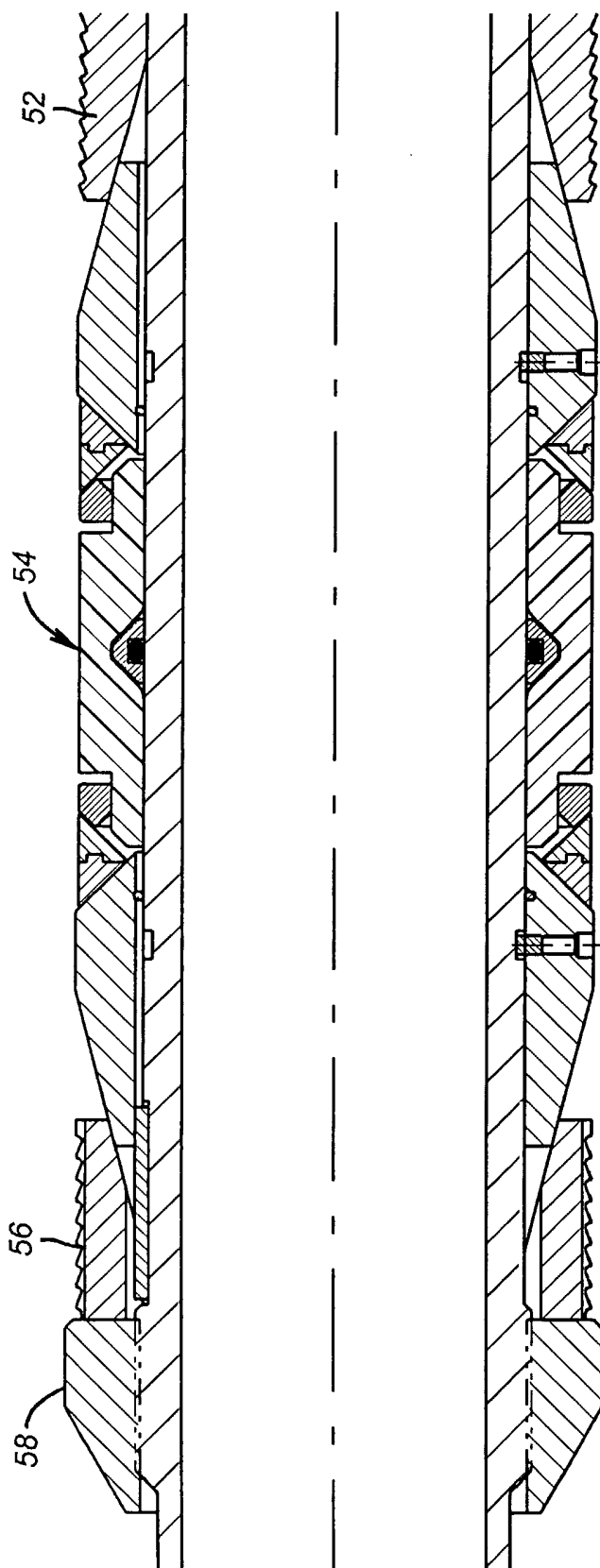

FIG. 1b

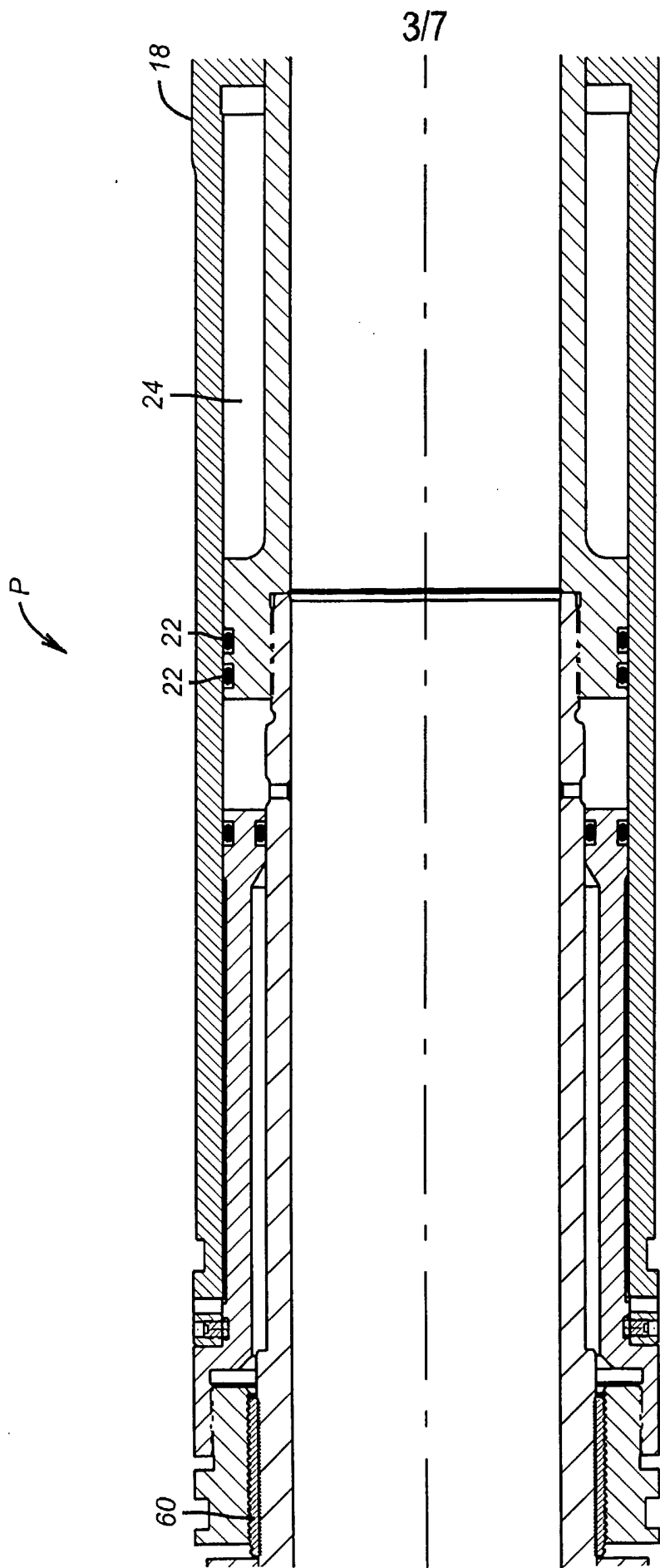

FIG. 1c

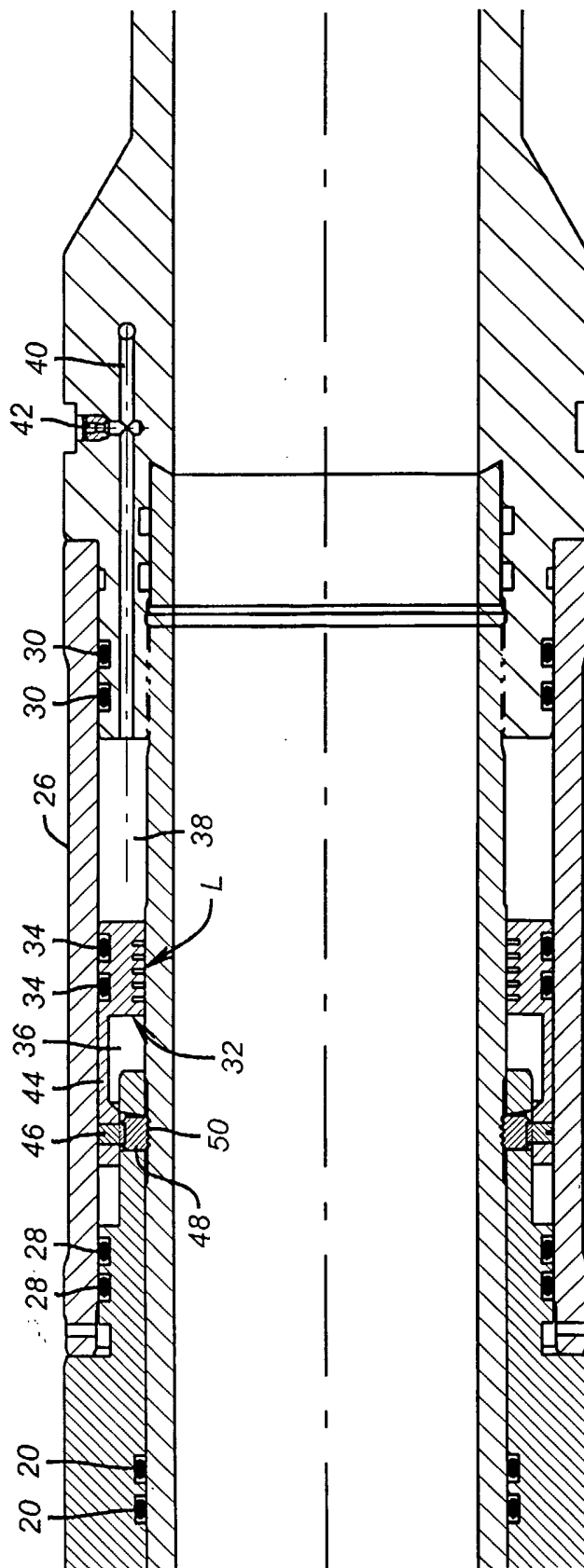

FIG. 1d

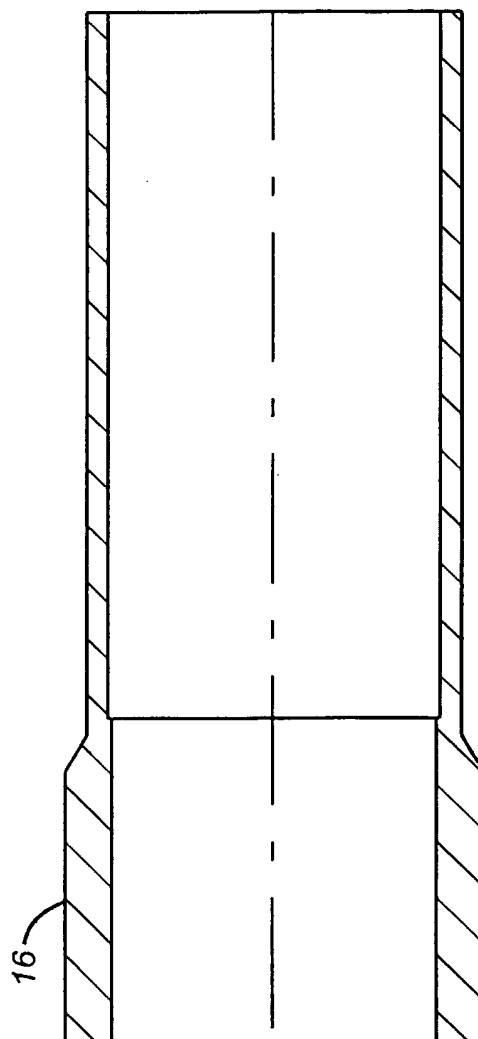

FIG. 1e

6/7

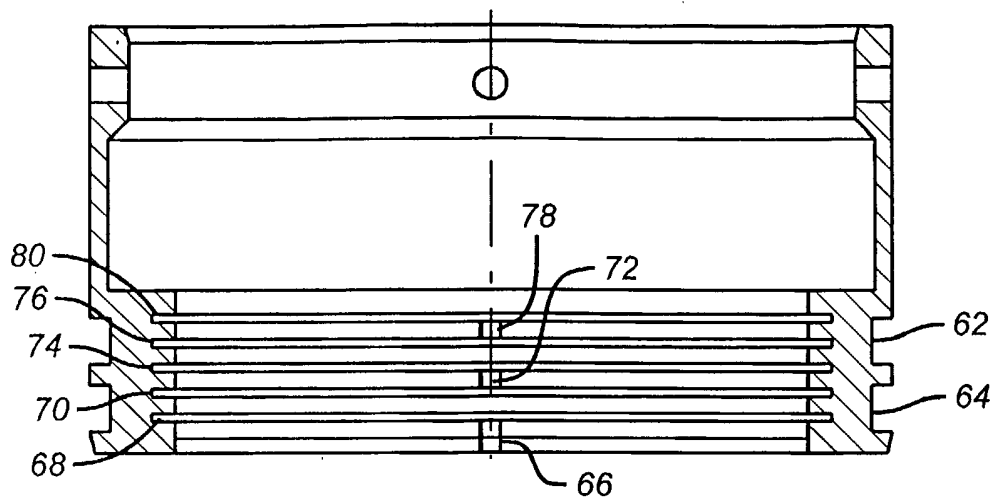

FIG. 2

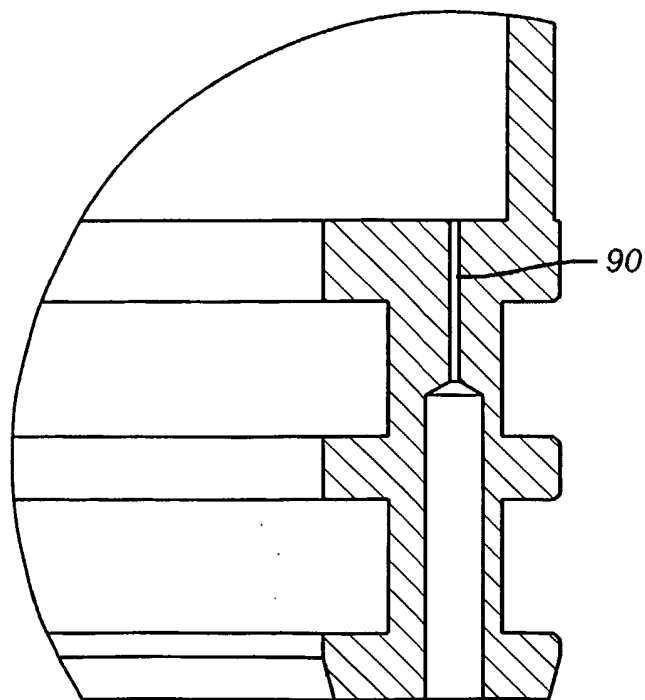

FIG. 3

7/7

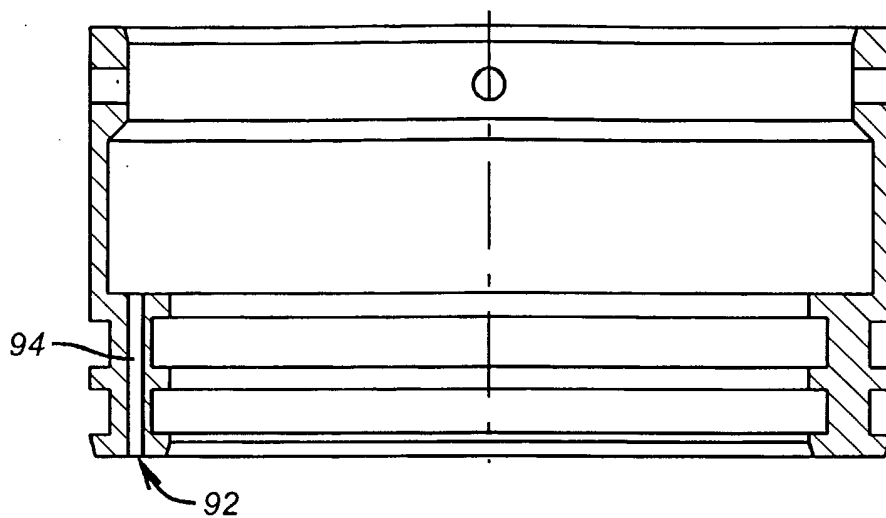

FIG. 4

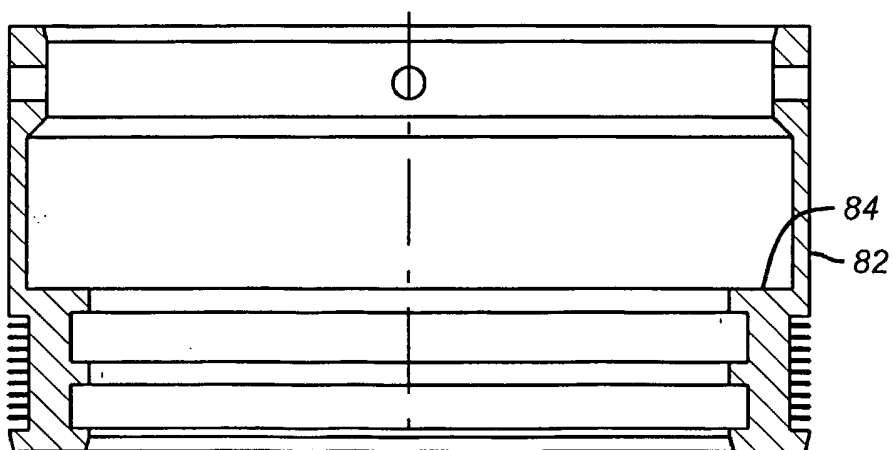

FIG. 5

INTERNATIONAL SEARCH REPORT

Int. Patent Application No
PCT/US 02/22993

A. CLASSIFICATION OF SUBJECT MATTER
IPC 7 E21B33/1295

According to International Patent Classification (IPC) or to both national classification and IPC

B. FIELDS SEARCHED

Minimum documentation searched (classification system followed by classification symbols)
IPC 7 E21B F16J

Documentation searched other than minimum documentation to the extent that such documents are included in the fields searched

Electronic data base consulted during the international search (name of data base and, where practical, search terms used)

EPO-Internal

C. DOCUMENTS CONSIDERED TO BE RELEVANT

Category °	Citation of document, with indication, where appropriate, of the relevant passages	Relevant to claim No.
X	DE 21 58 720 A (INDRAMAT GMBH) 30 May 1973 (1973-05-30) page 3, line 20 -page 4, line 4; figure 2 ---	10, 12
X	GB 2 320 269 A (SCHLUMBERGER LTD) 17 June 1998 (1998-06-17) page 10, line 1 - line 4; figure 3 ---	13, 14
X	US 5 803 179 A (PRESLEY REX D ET AL) 8 September 1998 (1998-09-08) figure 8 -----	10, 12

Further documents are listed in the continuation of box C.

Patent family members are listed in annex.

° Special categories of cited documents :

- *A* document defining the general state of the art which is not considered to be of particular relevance
- *E* earlier document but published on or after the international filing date
- *L* document which may throw doubts on priority claim(s) or which is cited to establish the publication date of another citation or other special reason (as specified)
- *O* document referring to an oral disclosure, use, exhibition or other means
- *P* document published prior to the international filing date but later than the priority date claimed

- *T* later document published after the international filing date or priority date and not in conflict with the application but cited to understand the principle or theory underlying the invention
- *X* document of particular relevance; the claimed invention cannot be considered novel or cannot be considered to involve an inventive step when the document is taken alone
- *Y* document of particular relevance; the claimed invention cannot be considered to involve an inventive step when the document is combined with one or more other such documents, such combination being obvious to a person skilled in the art.
- * & * document member of the same patent family

Date of the actual completion of the international search

24 September 2002

Date of mailing of the international search report

07/10/2002

Name and mailing address of the ISA

European Patent Office, P.B. 5818 Patentlaan 2
NL - 2280 HV Rijswijk
Tel. (+31-70) 340-2040, Tx. 31 651 epo nl,
Fax: (+31-70) 340-3016

Authorized officer

Ott, S

INTERNATIONAL SEARCH REPORT
 information on patent family members

International Application No
PCT/US 02/22993

Patent document cited in search report		Publication date	Patent family member(s)	Publication date
DE 2158720	A	30-05-1973	DE 2158720 A1	30-05-1973
<hr/>				
GB 2320269	A	17-06-1998	US 6085845 A	11-07-2000
			CA 2224258 A1	10-06-1998
			DK 143597 A	13-07-1998
			NL 1007743 C2	07-09-1998
			NL 1007743 A1	11-06-1998
			NO 975798 A	11-06-1998
			SG 60164 A1	22-02-1999
<hr/>				
US 5803179	A	08-09-1998	GB 2356879 A , B	06-06-2001
			GB 2359579 A , B	29-08-2001
			GB 2320938 A , B	08-07-1998
			NO 975808 A	01-07-1998
<hr/>				