

March 31, 1931.

P. A. BREDSVOLD

1,798,132

AUTOMOBILE HEAD LAMP

Filed April 25, 1928

6 Sheets-Sheet 1

Fig. 1.

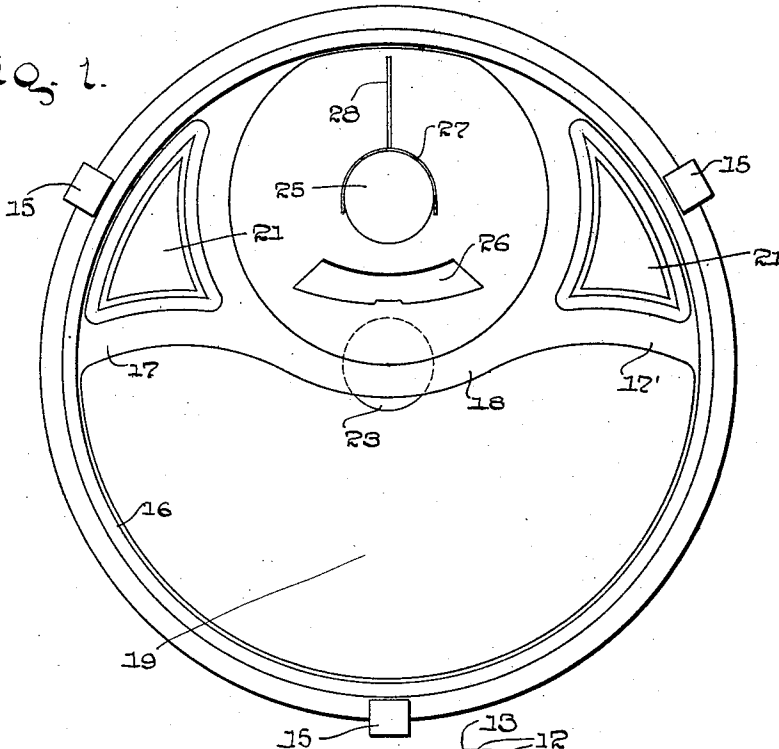
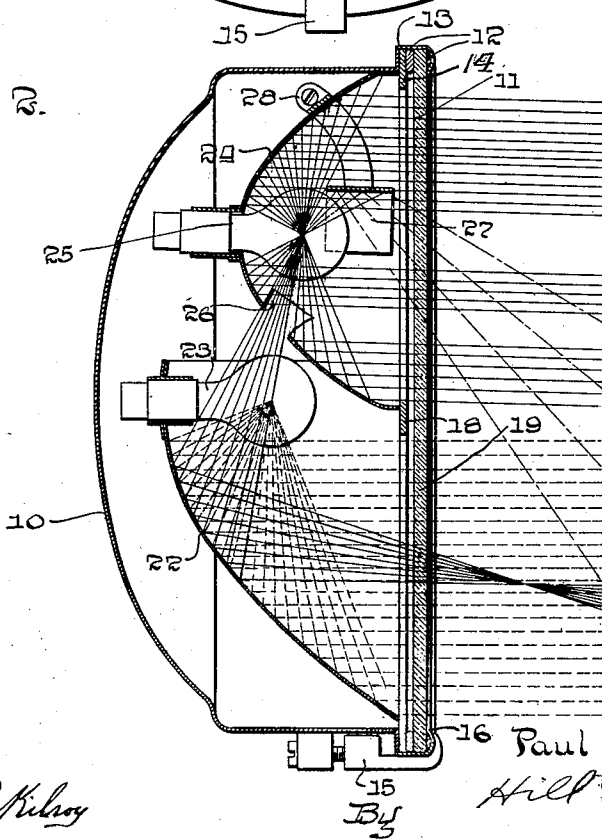

Fig. 2.



Witness  
 William R. Kilroy

Inventor  
 Paul A. Bredsvold  
 Hill & Hill  
 atty.



March 31, 1931.

P. A. BREDSVOLD

1,798,132

AUTOMOBILE HEAD LAMP

Filed April 25, 1928

6 Sheets-Sheet 3

Fig. 5

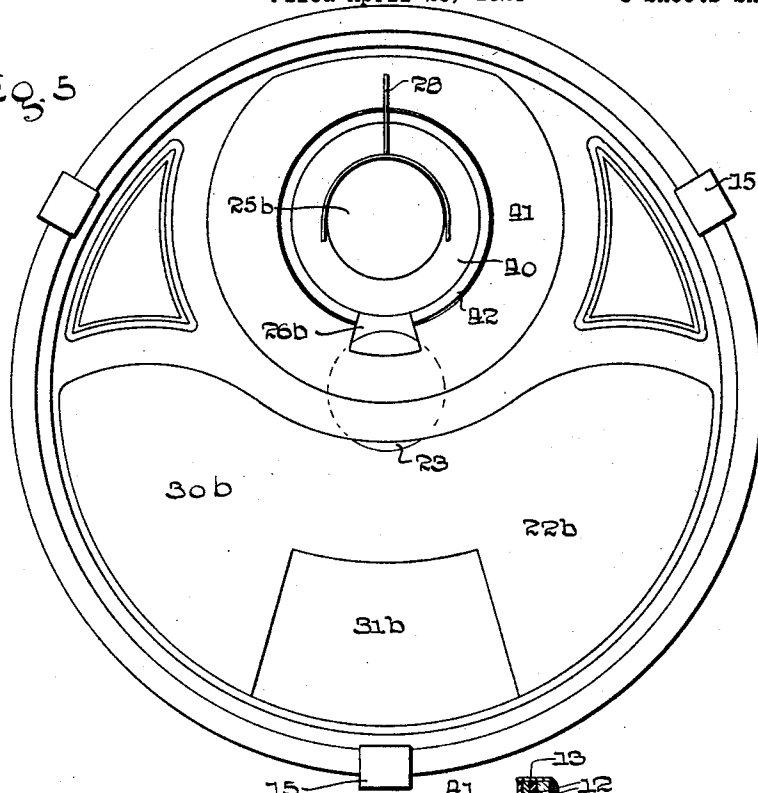
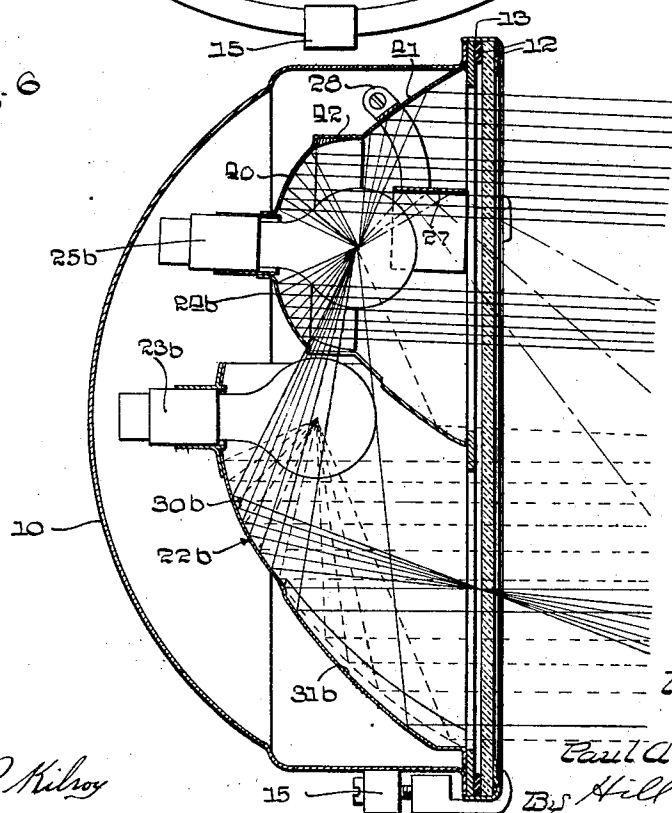

Fig. 6



Witness  
William P. Milroy

Inventor

Paul A. Bredsvold  
By Hill & Hill  
Attys

March 31, 1931.

P. A. BREDSVOLD

1,798,132

AUTOMOBILE HEAD LAMP

Filed April 25, 1928

6 Sheets-Sheet 4

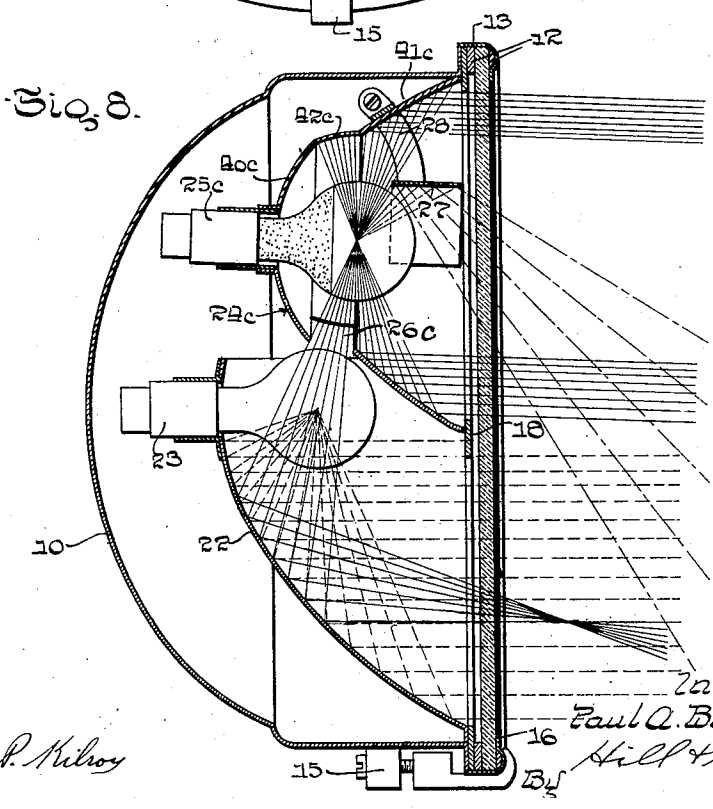
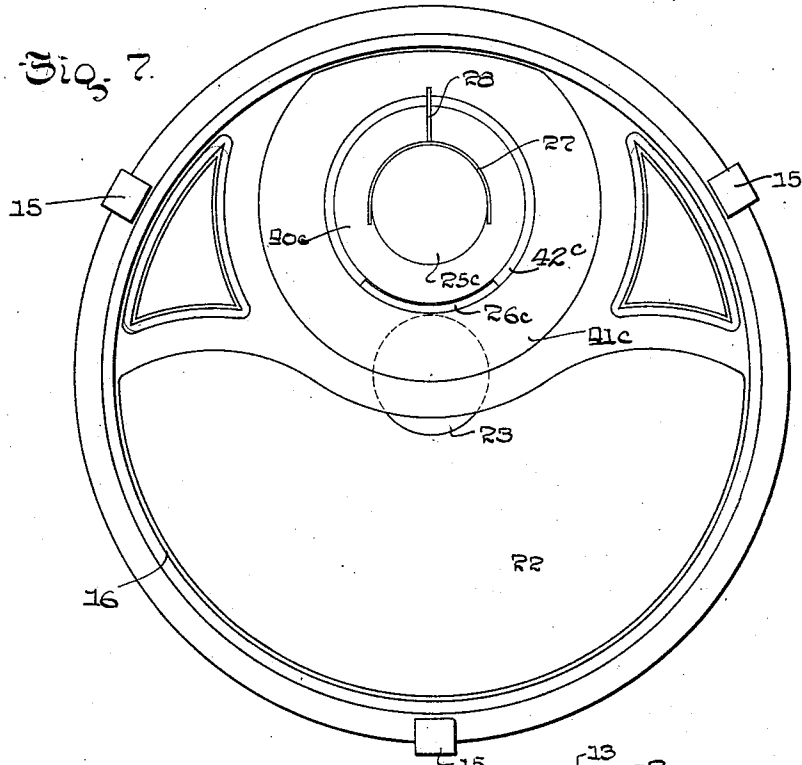

Witness  
William R. Kilroy

Inventor,  
Paul A. Bredsvold  
Hill & Hill  
Attys

March 31, 1931.

P. A. BREDSVOLD

1,798,132

AUTOMOBILE HEAD LAMP

Filed April 25, 1928

6 Sheets-Sheet 5

Fig. 9.

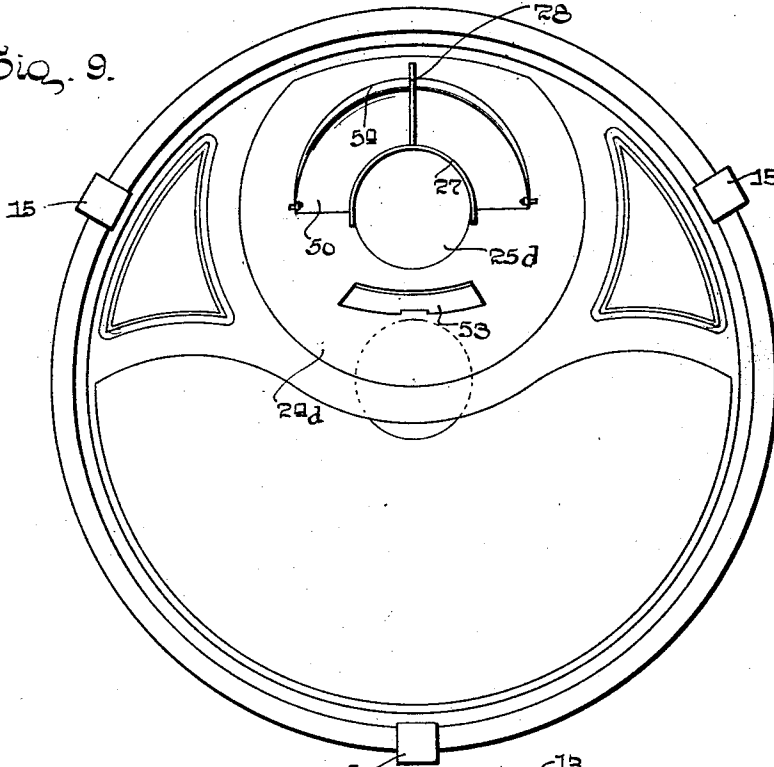
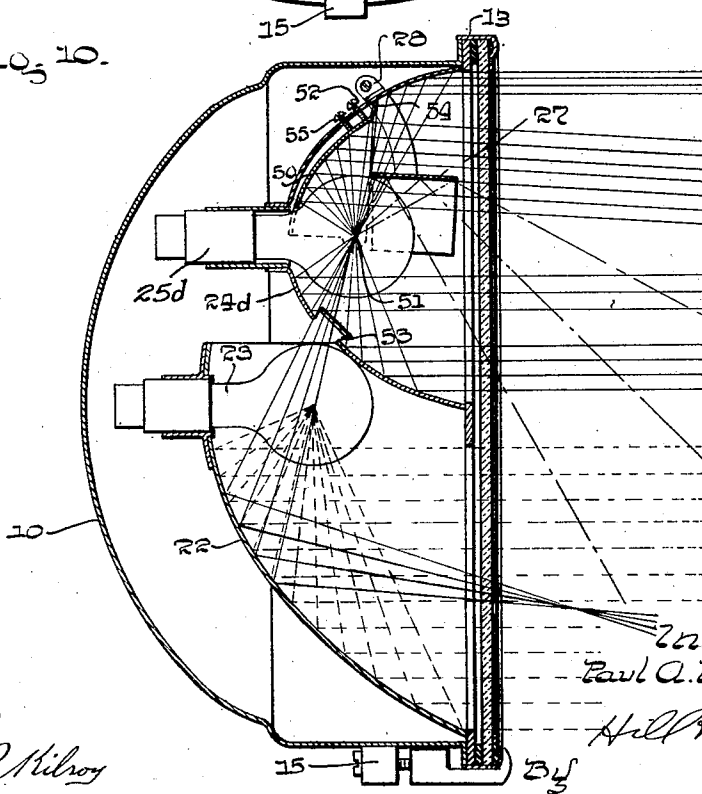

Fig. 10.



Witness  
William P. Hilroy

Inventor  
Paul A. Bredsvold

Hill & Hill

Attys.



# UNITED STATES PATENT OFFICE

PAUL A. BREDSVOLD, OF CHICAGO, ILLINOIS

## AUTOMOBILE HEAD LAMP

Application filed April 25, 1928. Serial No. 272,691.

My invention relates to reflecting lamps and has to do more particularly with devices commonly known as head lamps or head lights which are affixed to automobiles.

5 An object of my invention is to provide a head lamp which will project a beam of rays downwardly so as to strike the ground a short distance ahead and simultaneously project a parallel beam of rays nearly horizontally so as to strike the ground a great distance ahead, while avoiding the upward reflection of rays and shielding all the direct upward projection of rays from lamps within the head light casing.

15 A further object is to provide such a device as will project light of different intensities, at the will of an operator.

A still further object is to provide such a device with a plurality of reflecting surfaces so arranged that a plurality of light sources may be used either alone or to re-enforce each other, according to the will of an operator, each lamp being capable of acting upon such plurality of reflecting surfaces either alone or in combination with another lamp.

25 A still further object is to provide an efficient non-glare head lamp. Various other objects and advantages will appear as the description proceeds.

30 To this end, my invention consists in the novel construction, arrangement and combination of parts herein shown and described, and more particularly pointed out in the claims.

35 Referring now to the drawings forming a part of the specification, which illustrate certain preferred embodiments of my invention, and wherein like reference characters indicate like or corresponding parts;

40 Fig. 1 represents a front elevation of a lamp embodying my invention;

Fig. 2 represents a central sectional view of the device shown in Fig. 1;

45 Fig. 3 is a front elevational view of another embodiment of my invention;

Fig. 4 is a central sectional view of the device of Fig. 3;

50 Fig. 5 is a front elevation of still another embodiment of my invention;

Fig. 6 is a central sectional view of the device of Fig. 5;

Fig. 7 is a front elevational view of still another embodiment of my invention;

Fig. 8 is a central sectional view of the device of Fig. 7;

Fig. 9 is a front elevation of still another embodiment of my invention;

Fig. 10 is a central sectional view of the device of Fig. 9;

Fig. 11 is a front elevation of still another embodiment of my invention; and

Fig. 12 is a central sectional view of the device of Fig. 11.

65 Referring now to Figs. 1 and 2, a lamp embodying my invention is provided with a casing 10 of the usual sort, preferably of metal, which forms a housing for the parts which will now be described. Mounted in the front of the casing is a glass pane 11 preferably of clear plate glass, so as to transmit light rays without interference therewith. The pane 11 is seated in a flanged portion 12 of the casing between a pair of packing rings 13 of felt or other yielding material and is further held in place by a spacing member 14. Removable clamps 15 of any suitable design disposed at spaced points around the periphery of the flange 13 may serve to maintain the glass pane, the packing rings and the spacing member in fixed relation, although the glass pane may be secured to the frame by cement if desired.

75 The spacing member 14 may be of any suitable or desirable configuration, but as shown consists of an annular portion 16 and a pair of roughly triangular portions 17 and 17' which are joined by a web-like portion 18. It will thus be seen that the spacing member provides a substantially semi-circular lower opening 19 and a circular upper opening 20. The spacing member may be made of any suitable material, but is preferably formed of metal such as steel, and may be suitably ornamented as shown by colored glass inset portions 21 and 21'.

85 Mounted within the casing 10 is a shell-like member 22, formed of any suitable reflecting material such as silvered glass or highly polished metal, or the like, which is 100

curved to form a section of a concave paraboloidal surface. A lamp 23 is so mounted that the source of light given off by it will be positioned substantially at the focal point of the paraboloidal surface.

There is mounted within the upper part of the casing another shell-like member 24 which is preferably lined with a flat, white enamel, although it may be formed of material similar to the member 22 if desired, and which also has a concave paraboloidal reflecting surface, at the focal point of which is mounted a lamp 25. The member 24 is provided with a slot 26 in the lower part thereof. A shield 27 which may be provided with an inner reflecting surface is mounted by a suitable bracket 28 to depend within the paraboloidal member 24.

It will be seen that the rays of the lamp 23 which impinge upon the surface of the member 22 will be reflected substantially horizontally, in a parallel beam, inasmuch as this lamp is disposed substantially at the focal point of this paraboloidal surface. These rays, therefore, will be projected a great distance ahead of the automobile, at which point they may strike the ground. It will be understood that the lamp casing may be so mounted on the automobile that the horizontally projected rays will strike the ground at any desired distance ahead. Lamp 23 is preferably of high candle power so that this lamp alone will be suitable for emergency use when driving in the open country.

It will also be noted that the rays of the lamp 25 will be reflected straight ahead in a parallel beam by the paraboloidal surface of the member 24, inasmuch as the lamp 25 is disposed substantially at the focal point of the surface of this member. This member 24 is especially adapted to produce strong non-glare illumination of high efficiency. This lamp 25 may be of the same candle power as lamp 23 or of different candle power, as it produces no glare whatsoever and is suitable for driving in the city or in the open country inasmuch as it projects a beam of light straight ahead and also illuminates the ground immediately in front of the automobile. The inner reflecting surface of the shield 27 will reflect rays downwardly and to the sides.

It is, of course, obvious that for driving in the open country both lamps may be used simultaneously, if desired, in which case the lamp 25 will tend to reinforce the illumination of the lamp 23. However, lamp 23 will usually be switched on as an emergency beam when driving in the open country to detect suspected obstructions in the distance.

A great advantage of my invention is that substantially no light rays are reflected upwardly by either of the reflecting surfaces. The greater portion of the rays projected upwardly by the lamp 23 are shielded by the

member 24 and thus prevented from leaving the casing; while the rays projected upwardly by the lamp 25 are shielded by the member 27.

The embodiment shown in Figs. 3 and 4 is similar to that just described except in the following respects: Mounted in the casing 10 is a member 22a having a main concave paraboloidal reflecting surface as indicated by numeral 30 and a restricted portion 31, which may be formed integrally with the portion 30 or formed as an inset, which portion 31 is curved to form a concave paraboloidal reflecting surface of different curvature than the main portion 30. A lamp 23a is disposed substantially at the focal point of the main surface 30.

Mounted in the upper part of the casing is a member 24a having a concave paraboloidal reflecting surface, at the focal point of which is mounted a lamp 25a. The lamp 25a and the member 24a are so placed that the lamp 25a will also be at the focal point of the restricted paraboloidal reflecting surface 31. The member 24a is similar in configuration to the member 24 of Figs. 1 and 2, except that it has a substantially T-shaped slot having a portion 32 and a transverse portion 33. A shield 27 serving also as a reflector is provided as in the embodiment previously described.

It will be seen that, as in the previous embodiment, the rays of the lamp 23a impinging upon the surface 30 will be reflected substantially horizontally. The rays of the lamp 25a which impinge upon surface 30 will be reflected downwardly so as to strike the road a short distance ahead of the machine, while those rays which are projected through the transverse portion 33 of the slot will impinge upon the restricted reflecting surface 31. Inasmuch as the lamp 25a is disposed at the focal point at this restricted surface, such rays will be reflected substantially horizontally thereby. Hence it will be obvious that the embodiment of Figs. 3 and 4 will project a greater number of rays straight ahead than in the embodiment of Figs. 1 and 2, and, therefore, in open road driving, the amount of light by which lamp 25a will reinforce the lower lamp 23a will be greater than in the embodiment of Figs. 1 and 2. In other respects the operation of the two embodiments is substantially the same.

Referring now to Figs. 5 and 6, this embodiment is similar to those just described except in the following respects: Mounted within the casing 10 is a member 22b having a main concave paraboloidal reflecting surface 30b and a restricted concave paraboloidal reflecting surface 31b of different curvature from the main surface 30b. A lamp 23b is mounted substantially at the focal point of the main reflecting surface 30b. Arranged within the upper part of the casing 10 is a

member 24b having two concave paraboloidal reflecting surfaces 40 and 41 joined by a substantially spherical reflecting surface 42. A lamp 25b is so mounted as to be substantially  
 5 which focus coincides with that of the surfaces 40 and 41, it being understood that these three surfaces have a common focal point. The member 24b is provided with a slot 26b  
 10 lying in the bottom of the cylindrical portion 42 and of the paraboloidal portion 41.

It will be seen that the rays of the lamp 23b which impinge upon the main surface 30b are reflected substantially horizontally,  
 15 inasmuch as this lamp is mounted at the focus of said surface. Similarly, the rays of the lamp 25b which impinge upon the surfaces 40 and 41 will be reflected substantially horizontally for the same reason. Those rays of the  
 20 lamp 25b which are projected, either directly or by reflection from the spherical reflecting surface 42, through the slot 26b upon the restricted surface 31b will be reflected substantially horizontally from this surface, inasmuch  
 25 as the lamp 25b is disposed at the focal point thereof. Those rays of the lamp 25b which impinge upon the main reflecting surface 30b will be bent downwardly so as to strike the ground a short distance ahead. Most of the  
 30 rays from lamp 25b which impinge upon the spherical surface 42 will be reflected outwardly to the surface 41, which in turn will reflect them in a parallel beam.

Referring now to Figs. 7 and 8, the embodiment here illustrated is similar to the embodiments described above, except in the following respects.

A reflector 24c disposed in the upper part of the casing 10 comprises a concave paraboloidal reflecting member 40c and a spherical reflecting member 42c preferably formed  
 40 integral therewith, both of such surfaces preferably formed of a highly reflecting material such as silvered glass or of highly polished metal. Joined to the member 42c is  
 45 a second paraboloidal member 41c having a concave reflecting surface, this latter reflecting surface being preferably of a flat white such as a white enamel. The member 42c  
 50 is provided with a slot 26c in the lower part thereof.

As in the previous embodiments, a paraboloidal member 22 is provided in the lower part of the casing having a concave reflecting  
 55 surface, at the focus of which is mounted a lamp 23 and a second lamp 25c is disposed at the focal point of the members 40c and 41c. The lamp 25c is preferably etched or frosted on the surface toward the member 40c  
 60 representing slightly less than one-half of the globular surface of the lamp so as to produce a diffused glow by reflection from the surface 40c. A shield 27 supported on a bracket 28 is provided as in the other embodiments.

The embodiment just described has been

found to be efficient and satisfactory in operation. As in the other embodiments, the light from the lamp 23 which impinges upon the reflecting surface 22, will be reflected substantially horizontally in a parallel beam, inas-  
 70 much as this lamp is mounted at the focus of this surface. The light from the lamp 25c will be reflected horizontally from the paraboloidal surfaces 40c and 41c, and this lamp alone is usually found satisfactory and adequate for driving either in the city or on the  
 75 open road, while the lamp 23 may be used for emergency purposes. Because of the fact that a frosted lamp is used and furthermore, because of the white surface of the reflecting  
 80 member 41c, the light projected by the member 24c is non-glaring but of high intensity and efficiency, and hence is unobjectionable for either city or country driving. Some rays are reflected from the spherical surface 42c to  
 85 the surface 41c and thereby reflected in a parallel beam.

Referring to Figs. 9 and 10, there is disposed in the lower part of the casing 10 a paraboloidal member 22 exactly similar to the corresponding member of Figs. 1 and 2, having a  
 90 concave reflecting surface, at the focus of which is mounted a lamp 23. Disposed in the upper part of the casing 10 is a member 24d having a concave paraboloidal reflecting surface similar to that of the member 24 of Figs. 1 and 2. However, the member 24d differs from the member 24 in that there is provided therein a pivoted paraboloidal reflecting  
 95 member having an area substantially equal to that of the upper rear portion of member 24d and mounted on laterally extending pins 51 attached to the main body of the member 24d. The pivoted member 50 is provided with a  
 100 flange 54. Screws 52 and 55 are provided for adjusting the pivoted member 50 at the desired angle. This member is preferably formed of silvered glass or of highly polished metal, while the main portion of the reflecting  
 105 surface of member 24d is preferably coated with a flat white material such as enamel or the like. A lamp 25d is provided at the focus of the paraboloidal surfaces and there is a slot 53 in the lower part of the member 24d.  
 110

It will be noted that the member 24d is slightly tilted as is the corresponding member in the other embodiments illustrated, and that the shield 27 is likewise tilted in this  
 115 case. It will be obvious, of course, that the paraboloidal reflecting surface of the member 24d will reflect rays from the lamp 25d substantially horizontally in a parallel beam while the pivoted member 50 may be adjusted at any desired angle to reflect parallel rays at  
 120 any desired angle on the road more immediately in front of the automobile. The member 22, of course, will reflect a parallel beam substantially horizontally from lamp 23, as in the other embodiments.  
 125  
 130

The device shown in Figs. 9 and 10 is especially suitable for city driving and is particularly useful for trucks and the like inasmuch as a large amount of parallel beams may be projected a short distance ahead of the machine. The member 24*d* may be used very satisfactorily alone, especially on trucks and the like, and this is likewise true of the corresponding member shown in the other embodiments.

In all of the embodiments shown, it will be understood that the lamp disposed in the lower part of the casing, when used alone, will project certain rays upwardly through the slot in the upper reflecting member, which rays will be reflected by the surface of such member, and by the member 27, the slot being so disposed as to cut off most rays which might be reflected upwardly. Thus, either lamp, when used independently, will act upon a plurality of reflecting surfaces.

Referring to Figs. 11 and 12, an embodiment is shown here in which substantially similar results are accomplished as in the other embodiments by reversing the principal elements. Disposed in the upper part of the casing 10 is a paraboloidal member 22 having a concave reflecting surface, at the focus of which is mounted a lamp 23. This member has preferably a silvered surface, being preferably of silvered glass or polished metal. Mounted in the lower part of the casing is a paraboloidal member 60 having an offset portion 61, this member having preferably a flat white surface. Pivotaly supported by the member 60 by pins 62 or the like is a paraboloidal reflecting member 63, having a surface similar to that of the reflector 22. A lamp 64 is mounted so as to be substantially at the focus of these paraboloidal members. A shield 65 supported by a bracket 66 and having an inner reflecting surface depends within the member 60, and a slot 67 is provided in the upper portion of the member 60 and a slot 68 in the upper edge of the member 63 so disposed as to admit rays from lamp 23 onto the lower reflecting member 60 and similarly allow rays to pass upwardly from lamp 64 to member 22. Screws 69 are provided for adjusting the reflector 63 at the desired angle, it being understood of course that an opening is provided in the rear of this reflector for the passage of the lamp 64.

It will thus be seen that by means of this embodiment the reflector 63 can be adjusted at just the desired pitch to reflect a beam of parallel rays from the lamp 64 at the desired distance in front of the car, while a parallel beam will of course be reflected from this lamp by the member 60. The member 63 may be so adjusted as to throw rays a short distance in front of the automobile, if desired. The greater portion of the rays from the lamp 23 will of course be reflected sub-

stantially horizontally in a parallel beam by the member 22, inasmuch as the lamp 23 is mounted at the focus of this member. A portion, however, of the rays from the lamp 23 will be projected through the slots 67 and 68 onto the lower reflecting member from which they will be reflected downwardly and to the sides. Likewise certain rays from the lamp 64 will be projected upwardly onto the reflecting member 22, from which they will be reflected downwardly and to the sides as indicated by the arrows in Fig. 11. The device of this embodiment constitutes an efficient headlight and one which is adaptable to a variety of requirements.

It will readily be seen that my invention provides an efficient head lamp of simple design and compact construction which will provide the desired amount of light required either for city driving or for open road driving, and which will minimize the amount of light thrown upwardly to the annoyance of automobilists approaching from the opposite direction. It will be understood that the reflecting members shown in the various figures in the upper part of the casing 10 may be used very satisfactorily alone apart from and independently of the casing 10 and the lower reflecting members.

Having thus described my invention, it is obvious that various immaterial modifications may be made in the same without departing from the spirit of my invention as defined by the appended claims; hence I do not wish to be understood as limiting myself to the exact form, construction, arrangement and combination of parts herein shown and described, or uses mentioned. The term "highly reflecting surface" is used in the claims to include polished metal, silvered glass, or, in fact, any similar surface, as distinguished from a flat or non-glare surface.

What I claim as new and desire to secure by Letters Patent is:

1. In a device of the class described, the combination in a casing of a member having a surface capable of reflecting a parallel beam of light, a lamp disposed at the focus thereof, a member disposed within said casing having a similar reflecting surface and a lamp disposed at the focus thereof, and a reflector having a surface forming a continuation of that of said first-mentioned member and pivotaly adjustable therein so as to be capable of reflecting rays in a direction different from that of said first-mentioned member, one of said members being apertured to permit the passage of rays from one of said lamps to another of said members than that with which it is associated, to be reflected thereby.

2. In a device of the class described, the combination in a casing of a member having a surface capable of reflecting a parallel beam

of light, said surface being coated with a flat white material, a lamp disposed at the focus thereof, a member disposed within said casing having a surface also capable of reflecting a parallel beam of light, a lamp disposed at the focus of said last-mentioned member, and a reflector having a highly reflecting surface forming substantially a continuation of that of said first-mentioned member and pivotally adjustable therein, so as to be capable of reflecting rays in a direction different from that of said first-mentioned member, one of said members being apertured to permit the passage of rays from one of said lamps to another of said members than that with which it is associated, to be reflected thereby.

3. In a device of the class described, the combination in a casing of a member having a surface capable of reflecting parallel rays of light, a lamp disposed at the focus thereof, a member disposed within said casing having a similar reflecting surface and a lamp disposed at the focus thereof, a reflector having a surface forming a continuation of that of said first-mentioned member and pivotally adjustable therein so as to be capable of reflecting rays in a direction different from that of said first-mentioned member, one of said members being apertured to permit the passage of rays from each of said lamps to another of said members than that with which it is associated, to be reflected thereby.

4. In a device of the class described, a complete parabolic reflector, a one-half parabolic reflector positioned in the rear of the complete reflector, the two reflectors being placed one above the other, the complete reflector having a slot in one side facing the open side of the one-half reflector, the axes of the reflectors being parallel and inclined downwardly, and a lamp mounted at the focus of each reflector so as to project rays upon its respective reflector and through the slot upon the other reflector.

5. In a device of the class described, a complete parabolic reflector, a one-half parabolic reflector positioned in the rear of and underneath the complete reflector, the complete reflector having a slot in one side facing the open side of the one-half reflector, the axes of the reflectors being parallel and inclined downwardly, a lamp mounted at the focus of each said reflector, so as to emit rays upon its associated reflector and upon the other of said reflectors through said slot, a reflecting shield within the complete parabolic reflector, the position of the shield and the lower parabolic reflector being such that upwardly directed rays from either lamp are prevented from issuing forwardly.

In testimony whereof, I have hereunto signed my name.

PAUL A. BREDSVOLD.