

G. H. BILLINGS.

Improvement in Machines for Cold-Drawing Rods and Shafting.

No. 130,465.

Patented Aug. 13, 1872.

FIG. 1.

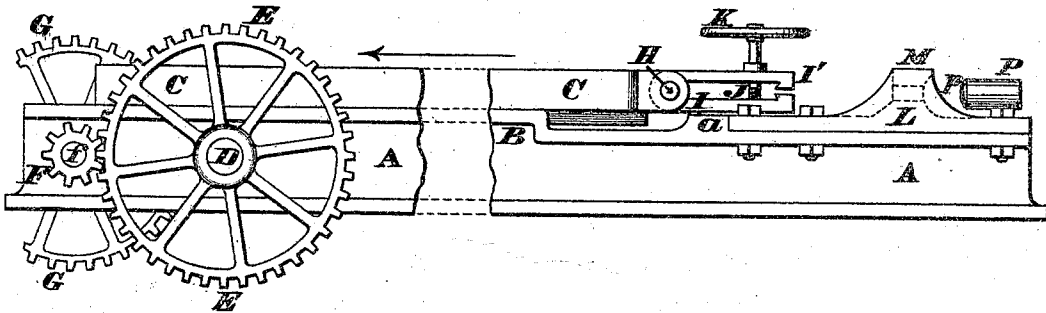

FIG. 2.

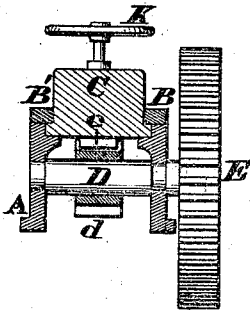

FIG. 3.

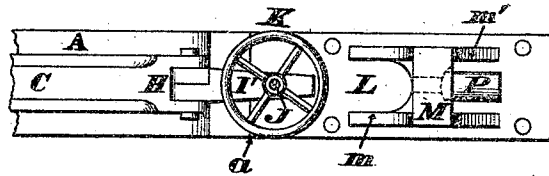
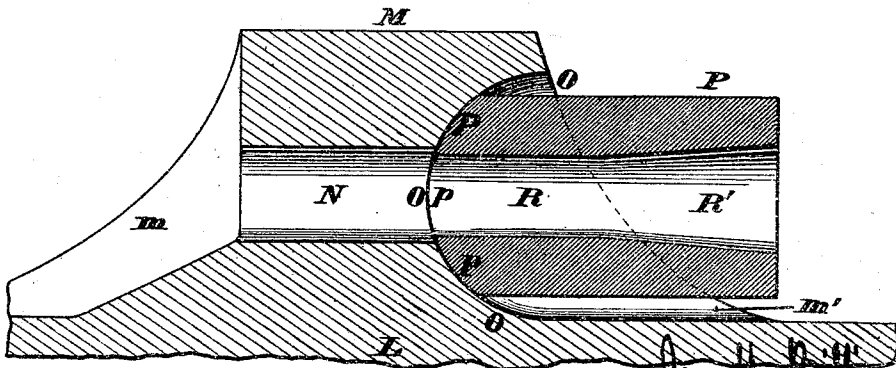

FIG. 4.



Attest.
Jas. H. Layman.
Walter Allen

Geo. H. Billings
Ray Knight
Att'ys.

UNITED STATES PATENT OFFICE.

GEORGE H. BILLINGS, OF CINCINNATI, OHIO.

IMPROVEMENT IN MACHINES FOR COLD-DRAWING RODS AND SHAFTINGS.

Specification forming part of Letters Patent No. 130,465, dated August 13, 1872.

Specification of an Improved Machine for the Manufacture of Cold-Drawn Rods, Shafting, &c., invented by GEORGE H. BILLINGS, of Cincinnati, Hamilton county, Ohio.

This invention relates to such machines as are employed in the manufacture of cold-drawn rods for shafting and other purposes, and my improvement consists in the provision of a self-centering die through which the rod is drawn. The object of this self-centering die is to insure a perfectly true and uniform rod, that will be free from bends and irregularities of any kind, and thereby obviate the necessity of a subsequent and special manipulation for the purpose of straightening the bar, as has heretofore been done.

Figure 1 is a side elevation of a machine embodying my improvements, the central portion thereof and a part of the gearing being broken away and the die shown detached. Fig. 2 is a transverse section of the same taken in the plane of the driving-shaft. Fig. 3 is a plan of the end of the machine that receives the self-centering die, the latter being in position; and Fig. 4 is an enlarged vertical section, showing the self-centering die in position for use.

A represents the frame of the machine, which is from forty to sixty feet in length and stout enough to resist the immense strain that is brought to bear upon it. This frame is provided with guides B B', for the purpose of confining to a rectilinear path a carriage or draw-bar, C, whose under side is furnished with a rack, c, that gears with a pinion, d, upon the driving-shaft D. This shaft carries a spur-wheel, E, which meshes with a pinion, F, whose shaft f may be driven either by a spur-wheel, G, or any other suitable mechanical device that will impart sufficient power. That end of the draw-bar C which is most remote from the driving-gearing has pivoted to it, at H, two jaws, I I', between which the rod to be operated upon is securely clamped by the screw J and hand-wheel K. The frame A has a jog at a, which serves as an abutment for a heavy bed-plate, L, the latter being furnished with a bridge, M, that is connected to said bed-plate by the webs m m'. The bridge M is provided with a bore, N, which communicates with the concave seat or socket O that is formed in the receiving side of said bridge. Seated in this

socket is my self-centering die, which is constructed as follows: P is a short steel cylinder having a convex end or head, p, whose curvature corresponds with that of the socket O, and said cylinder is traversed axially by a bore, R, which extends in cylindrical form about one half of the length of the die, from which point it flares slightly to its receiving end, as shown at R'. The diameter of the part R of the die corresponds with that of the finished rod, and that of the mouth or widest portion R' is slightly in excess of the original rod. The opening N in the bridge may be of any suitable dimensions, as it performs no function in the operation of drawing the rod.

My machine is operated in the following manner: One end of the rod to be operated upon is first reduced in diameter by hammering so as to pass readily through the bore R, when the die P is seated in the socket O, which location of the die is clearly shown in Fig. 4. The reduced and protruding end of the rod is then inserted between the jaws I I' and securely clamped by the screw J, after which the gearing is rotated in such a manner as to propel the carriage C in the direction indicated by the arrow. As the carriage is thus retracted the bar is drawn completely through the die and is thereby subjected to an intense circumferential compression, which serves to compress and condense the fibers of the iron and thus add greatly to its strength. The converging portion R' of the die causes the compression of the rod to be effected gradually, and, therefore, there is no danger of breaking the rod or bursting the die, besides which the friction of the operative parts is reduced to minimum.

The great advantageous feature peculiar to my machine consists in the provision of the concave recess O and convex head p of the die, as by this arrangement the latter is self-centering and its axis is always in line with the center of the clamps I I', no matter how much said clamp may vibrate either vertically or horizontally. The die being always maintained directly in line with the power that is drawing the rod through, the latter is consequently perfectly straight and uniform, and is ready for use as soon as it leaves the machine, without any finishing or other manipulation whatever. Whenever the reducing

die is a fixture in the machine, the rod will always be more or less sprung, on account of its being impossible to adjust the clamp so as to maintain the rod directly in line with said die, and the rod, after being taken from the machine, must be straightened by special appliances, which is an expensive and unsatisfactory operation, as the rod is frequently indented or otherwise injured. The form of the opening N in the bridge M is a matter of no consequence, as it has nothing whatever to do with imparting the desired shape to the rod; but said opening should be of sufficient diameter to admit freely the largest-sized rod.

The machine may be employed for reducing rods for shafting, sash-iron, fender-work, or for any other purpose where a true and finished

rod or bar is required. Before being drawn the rod may be tinned, zincd, or nickel-plated.

Claim.

I claim as my invention—

The provision, in a machine for drawing rods, &c., of the self-centering die P p, R R', when used in connection with the concave seat O and opening N, substantially as herein described.

In testimony of which invention I hereunto set my hand.

GEORGE H. BILLINGS.

Attest:

GEO. H. KNIGHT,
JAMES H. LAYMAN.