

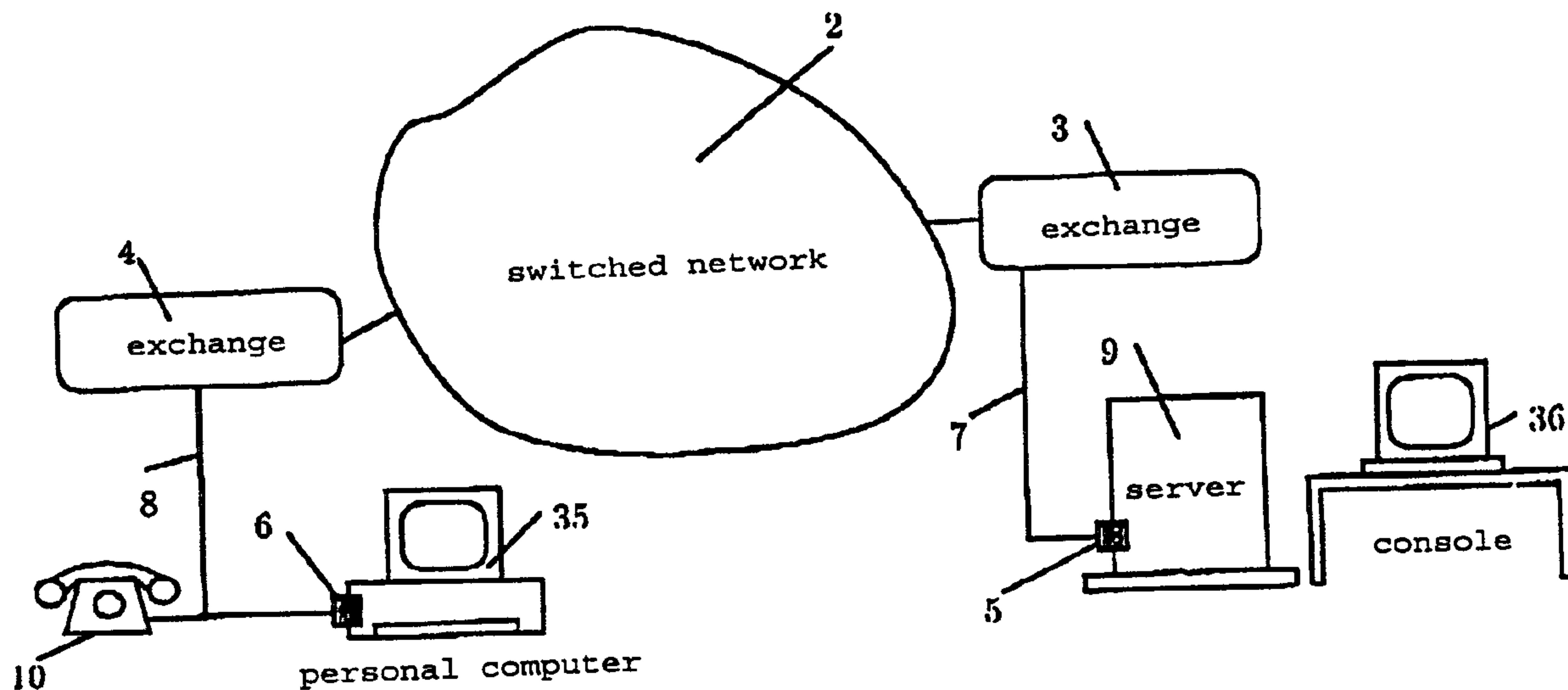

(86) Date de dépôt PCT/PCT Filing Date: 1996/10/23
 (87) Date publication PCT/PCT Publication Date: 1997/05/01
 (45) Date de délivrance/Issue Date: 2003/10/14
 (85) Entrée phase nationale/National Entry: 1998/04/22
 (86) N° demande PCT/PCT Application No.: FR 1996/001657
 (87) N° publication PCT/PCT Publication No.: 1997/016009
 (30) Priorité/Priority: 1995/10/23 (95/12672) FR

(51) Cl.Int.⁶/Int.Cl.⁶ H04M 7/00
 (72) Inventeur/Inventor:
HUMBLET, PIERRE, FR
 (73) Propriétaire/Owner:
MOTOROLA, INC., US
 (74) Agent: GOWLING LAFLEUR HENDERSON LLP

(54) Titre : DISPOSITIF ET PROCEDE DE COMMUNICATION NUMERIQUE-ANALOGIQUE
 (54) Title: DIGITAL-TO-ANALOG COMMUNICATION DEVICE AND METHOD



(57) Abrégé/Abstract:

A device for communication between a digital adapter (5) connected to an exchange (4) via a digital interface (7), particularly an ISDN interface, and an analog adapter (6) connected to an exchange (3) via an analog interface (8). Said exchanges (3, 4) are interconnected via a telecommunications network (2). The device comprises means (11, 12; 15, 16) for directly linking the digital adapter (5) and the analog adapter (6). Digital data from the digital adapter (5) is transmitted in digital form to the analog adapter (6), and vice versa, without emulating an analog signal.



PCT

 ORGANISATION MONDIALE DE LA PROPRIÉTÉ INTELLECTUELLE
 Bureau international

DEMANDE INTERNATIONALE PUBLIÉE EN VERTU DU TRAITE DE COOPERATION EN MATIÈRE DE BREVETS (PCT)

(51) Classification internationale des brevets ⁶ : H04L 27/00, H04B 14/02, 3/23	A1	(11) Numéro de publication internationale: WO 97/16009 (43) Date de publication internationale: 1er mai 1997 (01.05.97)
(21) Numéro de la demande internationale: PCT/FR96/01657 (22) Date de dépôt international: 23 octobre 1996 (23.10.96) (30) Données relatives à la priorité: 95/12672 23 octobre 1995 (23.10.95) FR (71) Déposant (pour tous les Etats désignés sauf US): INSTITUT EURECOM G.I.E. [FR/FR]; 2229, route des Crêtes, Boîte postale 193, F-06904 Sophia-Antipolis (FR). (72) Inventeur; et (75) Inventeur/Déposant (US seulement): HUMBLET, Pierre [BE/FR]; 65, boulevard Montfleuri, F-06400 Cannes (FR). (74) Mandataire: NONNENMACHER, Bernard; Transall S.A.R.L., Jazz 2, domaine de l'Etoile, F-06610 La Gaude (FR).	(81) Etats désignés: BR, CA, CN, MX, NO, PL, RU, UA, US, brevet européen (AT, BE, CH, DE, DK, ES, FI, FR, GB, GR, IE, IT, LU, MC, NL, PT, SE). Publiée <i>Avec rapport de recherche internationale.</i> <i>Avant l'expiration du délai prévu pour la modification des revendications, sera republiée si de telles modifications sont reçues.</i>	

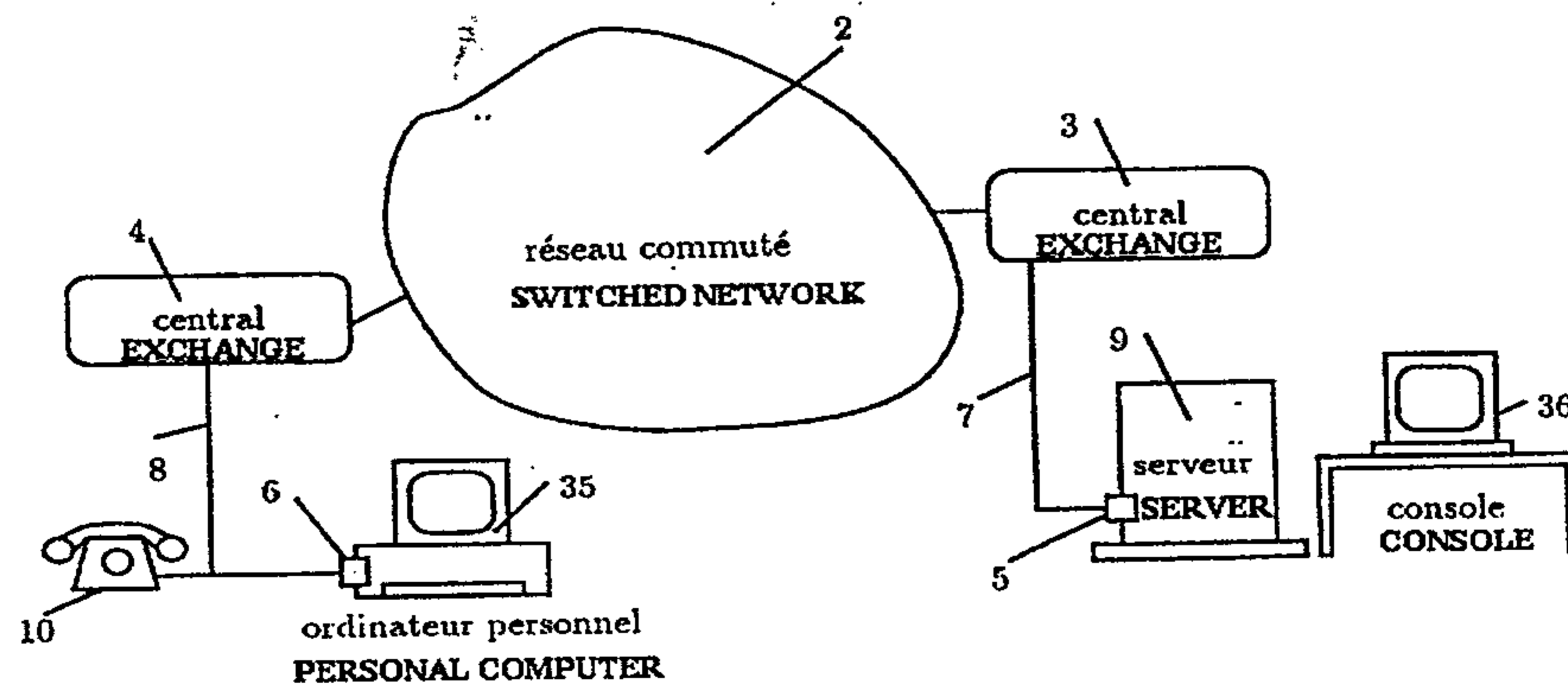
(54) Title: DIGITAL-TO-ANALOG COMMUNICATION DEVICE AND METHOD
(54) Titre: DISPOSITIF ET PROCÉDE DE COMMUNICATION NUMÉRIQUE-ANALOGIQUE

(57) Abstract

A device for communication between a digital adapter (5) connected to an exchange (4) via a digital interface (7), particularly an ISDN interface, and an analog adapter (6) connected to an exchange (3) via an analog interface (8). Said exchanges (3, 4) are interconnected via a telecommunications network (2). The device comprises means (11, 12; 15, 16) for directly linking the digital adapter (5) and the analog adapter (6). Digital data from the digital adapter (5) is transmitted in digital form to the analog adapter (6), and vice versa, without emulating an analog signal.

(57) Abrégé

Ce dispositif de communication entre un adaptateur numérique (5) relié à un central (4) par l'intermédiaire d'une interface numérique (7), notamment de type RNIS, et un adaptateur analogique (6) relié à un central (3) par l'intermédiaire d'une interface analogique (8), lesdits centraux (3, 4) étant reliés par l'intermédiaire d'un réseau de télécommunications (2), est caractérisé en ce qu'il comporte des moyens (11, 12; 15, 16) de liaison directe entre l'adaptateur numérique (5) et l'adaptateur analogique (6), l'information numérique de l'adaptateur numérique (5) étant envoyée à l'adaptateur analogique (6), et réciproquement, sous forme numérique sans émuler un signal analogique.

Digital-To-Analog Communication Device And Method

Field of Invention

The present invention relates to a device for hybrid digital/analog communication on a telephone channel, and a method of transmission able to be
5 employed by such a device.

Background of the Invention

The growth in the installed base of personal computers and the emergence of new data communications services testify to the potential for growth in the volume of on-line communications. Although the current
10 situation is satisfactory for large-scale users who are able to connect their internal networks to external services via high-speed transmission networks or leased lines, the cost of such solutions is too high for small businesses or individuals.

15 It seems certain that this situation will change, and that the necessity of distributing services involving a high transmission rate right to private residences will be at the origin of a widespread broadband network. However, there is little chance of
20 such a network being deployed globally for several years, or even tens of years.

While awaiting the availability of such a high-speed network, individuals, schools and small businesses have to resort to transmitting data on the
25 telephone network. To do that, they have the choice between two known technologies. The most widespread solution consists in using modems operating at a rate of 14.4 kb/s or 28.8 kb/s. A more expensive solution consists in using the ISDN network, which has two data
30 channels at 64 kb/s and a signaling channel at 16 kb/s. However, this second solution is not available everywhere, and requires substantial investment for the users in the form of higher subscriber tariffs and suitable communications hardware.

35 A modem is known from EP-A-0 669 740 from AT&T Corp. which is intended to be used with analog subscriber lines at the two ends of the transmission path. This modem comprises means for separately

equalizing each loop of an analog telephone network connection, by using a plurality of transmission filters and a plurality of reception filters. The filters are used in such a way that, in the direction
5 of transmission from the modem to the exchange, the voltage samples sent by the coding/decoding stations are equivalent to the quantization levels of the exchange.

The need to use prescribed levels for the
10 quantization law makes it impossible to choose the levels which have the best resistance to noise in the presence of an echo signal.

Furthermore, the above document does not describe a device for communication between a digital adapter
15 and an analog adapter, in which the digital adapter would be linked to an exchange via a digital interface.

Summary of the Invention

The object of the invention is to propose a third alternative, which is able to use the advantages of a network such as, for example, the ISDN network,
20 and particularly a higher transmission speed, of the order of 64 kb/s, while not entailing additional costs particularly for users, with respect to the cost of conventional solutions operating at 14.4 kb/s.

To that end, the invention relates to a device
25 for communication between a digital adapter linked to an exchange by means of a digital interface, particularly of ISDN type, and an analog adapter linked to an exchange by means of an analog interface, said exchanges being linked by means of a telecommunications
30 network, which includes means for direct linking between the digital adapter and the analog adapter, the digital information from the digital adapter being sent to the analog adapter, and vice versa, in the digital form without emulating an analog signal.

35 According to other characteristics of the invention:

- said direct link means include, in the direction of transmission going from the digital

adapter to the analog adapter, a digital transmitter situated in the digital adapter and able to transmit, to an analog receiver situated in the analog adapter, analog pulses the voltage levels of which represent the information transmitted from the digital adapter to the analog adapter;

- said direct link means include, in the direction of transmission going from the analog adapter to the digital adapter, an analog transmitter situated in the analog adapter and able to transmit, to a digital receiver situated in the digital adapter, an analog signal such that, when it is sampled by the analog interface of the exchange, it will equate to the sum of a value able to be determined by the digital information item transmitted by the analog adapter to the digital adapter, and of the echo of the signal transmitted by the digital adapter, without the said value having to be equal to a level of the quantization law,

- the receiver of the analog adapter includes an adaptive linear equalizer connected at its input to the output of an analog/digital converter, and connected at its output to the input of an output equalizer linked to the user's equipment, so that the response at the output of the adaptive linear equalizer is a partial response, for example a class IV response.

- said output equalizer is a decision feedback equalizer or a Viterbi equalizer.

- said partial response is determined adaptively,
- said output equalizer is a decision feedback equalizer or a Viterbi equalizer,

- said means include, at the digital adapter end, an n-level selector, n being equal, particularly, to 64, which are represented in the form of a byte, from among $N = 256$ possible quantization levels, said level selector being connected, at its input, to the user's equipment and, at its output, to a digital interface;

- the transmitter of the analog adapter includes a line coder followed by a predistortion filter which synthesizes a partial response, for example a class IV partial response.

5 - said partial response is determined adaptively;

 - the digital adapter includes a decoder connected, at its input, to an echo filter and to the output of the digital interface of the digital adapter, said decoder delivering at its output to the user's
10 equipment the most likely sequence of groups of bits transmitted by the analog adapter, given the echo of the signal produced by the digital adapter.

The invention also relates to a method of direct transmission between an analog adapter and a digital
15 adapter, bidirectionally.

In the direction of transmission going from the digital adapter to the analog adapter, this method includes stages consisting in:

 - taking a group of bits originating from a
20 source of digital data, for example a group of 6 bits;

 - choosing one from among n ($n = 64$) levels preselected from among N ($N = 256$, in particular) voltage levels, each level being represented in digital form by one byte;

25 - successively sending the bytes corresponding to the selection of one from among n levels through the digital network to an analog adapter, so as, in the analog adapter, to produce signals the amplitude of which is substantially equal to the levels represented
30 by each byte, the signals corresponding to successive bytes interfering with one another so as to produce a resultant analog signal in the analog adapter;

 - equalizing said resultant analog signal so as to eliminate the interference;

35 - measuring the amplitude of the resultant analog signal and deducing the digital value of the byte therefrom;

- from the digital value of the byte, reconstituting the group of bits and sending it to a digital data receiver.

The method of transmission from an analog adapter to a digital adapter in a communications system includes the stages consisting in:

- taking a group of bits originating from a data source connected to the communications system;
- selecting an analog signal having an amplitude corresponding to the digital value of the group of bits, the signals corresponding to successive groups interfering with one another and having a shape such that, at the moment when the analog signal is sampled in the analog interface of the exchange, its value is substantially equal to the sum of a value able to be determined by the digital information item transmitted by the analog adapter to the digital adapter, and of the echo of the signal transmitted by the digital adapter, without said value having to be equal to a level of the quantization law, so that following the sampling of the analog signal, a byte appears in the digital adapter, representing the said sum;
- processing the successive bytes so as to retrieve the most likely sequence of the group of bits, given the echo of the signal transmitted by the digital adapter;
- transmitting the digital value of the groups of bits retrieved to the user's equipment.

Brief Description of the Drawings

The invention will be better understood on reading the following description given by way of non-limiting example, and by the attached drawings, in which:

- Figure 1 represents a theoretical diagram of the communications device implementing the invention;
- Figure 2 represents a graph of the maximum transmission rate for a type A quantization law, as a function of the minimum distance between the n chosen quantization levels;

- Figure 3 represents a theoretical diagram of a digital adapter suitable for the device according to the invention;

5 - Figure 4 represents a theoretical diagram of an analog adapter suitable for the device according to the invention.

Detailed Description of the Preferred Embodiment

Referring to figure 1, the overall architecture of a communications device 1 is represented in this figure, using a public switched network 2 for the
10 transmissions between two exchanges 3, 4 linked respectively, at one end, to a digital adapter 5 via a digital interface 7, and, at the other end, to an adapter 6 called analog adapter, that is to say one connected by a simple conventional telephone interface
15 8.

A digital server 9, which is, for example, a server accommodating high-speed applications, is connected to the digital exchange 3 by a line 7 and a digital adapter 5 of the server 9.

20 The terminal 35 takes the form, particularly, of a personal computer connected to the analog adapter 6. The adapter and a telephone 10 are connected by the simple telephone line 8 to the exchange 4. Hence, analog information transits on the analog line 8: the
25 telephone 10 user's voice, or digital information output by or addressed to the analog adapter 6.

By virtue of this architecture, which is known in the case in which the analog adapter is a conventional modem, it is possible to call a
30 conventional analog line 8 from a server 9, and vice versa. This possibility is already used to transmit speech or data. When the digital signal originating from a digital adapter 5, after transport by the network 2, arrives at the telephone exchange 4, the
35 bytes of the digital signal are converted, by a digital/analog converter incorporated in the exchange 4, into voltage levels, which is done at a sampling frequency which is normally 8,000 times per second.

This digital/analog (D/A) conversion takes place according to a conversion law, for example the "A" law in Europe, or the " μ " law in other parts of the world. In the other direction, that is to say in the direction
5 from the analog adapter 6 to the digital adapter 5, the analog voltage received by the exchange 4 is digitized by a sampler and represented by bytes. These bytes, after transport by the network 2, are sent to the digital adapter 5.

10 Overall, a connection as described above allows a digital adapter 5 to communicate with an analog adapter 6.

Traditionally, the digital adapter 5 sends a sequence of bytes which, after conversion using an
15 abovementioned law, correspond to a speech signal, or to a conventional modem signal. This signal is then processed normally; in the case of telephony, it is sent directly to the earpiece of the telephone handset
10. Similarly, the analog adapter 6 traditionally
20 consists of a modem. The reverse operations are performed in the other direction of transmission.

The invention proposes another method of transmission between an analog adapter 6 and a digital adapter 5, and a corresponding device.

25 The principle of the invention is explained in connection with Figure 2, which represents the compromise which exists between the transmission speed (in kilobits/second on the ordinate scale) and resistance to noise. If it is desired to transmit at
30 64 kb/s, all 256 quantization levels possible from eight bits ($2^8 = 256$) have to be used. However, for transmission subject to Gaussian noise, the error probability in the course of transmission depends on the minimum distance d_{\min} (on the abscise of Figure 2)
35 between two adjacent levels of the quantization scale, and this relationship is represented in Figure 2, for a type A conversion law. It is noted, surprisingly, that by increasing the minimum distance d_{\min} between levels

from 2 to 4, not half of the quantization levels are lost, but only 33 levels out of 256. It results therefrom, similarly, that transmission at about 48 kb/s remains possible by using only 64 quantization
5 levels separated by a distance of $d_{\min} = 128$.

The stages of the method of transmission in the two directions are then as follows, when the analog signal is quantified with respect to $n = 64$ levels, allowing a rate of 48 kb/s.

10 For the method of transmission from a digital adapter to an analog adapter, the stages of the method comprise the following stages:

- taking a group of bits originating from a digital data source, for example a group of 6 bits;
- 15 - choosing one from among n ($n = 64$, in particular) levels preselected from among N ($N = 256$, in particular) voltage levels, each level being represented in digital form by one byte transmitted 8000 times per second;
- 20 - successively sending the bytes corresponding to the selection of n levels through the digital network to an analog adapter, so as, in the analog adapter, to produce signals the amplitude of which is substantially equal to the levels represented by each byte, the
25 signals corresponding to successive bytes interfering with one another so as to produce a resultant analog signal in the analog adapter;
- equalizing said resultant analog signal so as to eliminate the interference;
- 30 - measuring the amplitude of the resultant analog signal and deducing the digital value of the byte therefrom;
- from the digital value of the byte, reconstituting the group of bits and sending it to a
35 digital data receiver.

The method of transmitting from an analog adapter to a digital adapter in a communications system includes the stages consisting in:

- 8000 times per second, taking a group of bits originating from a data source connected to the communications system;

- selecting an analog signal having an amplitude corresponding to the digital value of the group of bits, the signals corresponding to successive groups interfering with one another, and having a shape such that, at the moment when the analog signal is sampled in the analog interface (8) of the exchange (4), its value is substantially equal to the sum of a value able to be determined by the digital information item transmitted by the analog adapter (6) to the digital adapter (5), and of the echo of the signal transmitted by the digital adapter (5), without said value having to be equal to a level of the quantization law, so that following the sampling of the analog signal, a byte appears in the digital adapter (5), representing the said sum;

- processing the successive bytes so as to retrieve the most likely sequence of the groups of bits, given the echo of the signal transmitted by the digital adapter;

- transmitting the digital value of the groups of bits retrieved to the equipment of the user.

Overall, the method of transmission does not try to reconstruct an analog signal for transmission on line to the analog adapter. On the contrary, the bytes which represent the digital information are converted directly into voltage levels, as illustrated by the corresponding device in the upper part of Figure 3, which concerns the transmission part of the digital adapter 5. For example, in order to communicate at 48 kb/s, the digital adapter 5 converts the bits received from the user into groups of 6 bits representative of voltage levels (i.e. $2^6 = 64$ possibilities), sent 8000 times per second, and representing one from among the 256 levels of the conversion law. The 64 levels thus used in this example

are chosen in such a way as to be separated from one another as far as possible so as to provide better resistance to noise. This separation is called the minimum distance d_{\min} in what follows. The benefit of this approach is of eliminating the quantization noise introduced by the conversion law.

It should be noted that it is also possible to envisage, in a way known per se, using trellis-coded modulation in order to obtain better resistance to noise.

For interfacing with the interface 7, the digital adapter 5 principally includes an upper part (above the horizontal broken line) consisting of a digital transmitter 11, and a lower part 12 consisting of a digital receiver. The input of the digital transmitter 11 is fed from a digital data source, such as by the server 9 (Figure 1). The input of the digital transmitter 11 which sees bytes passing representing the digital information coming from the server 9, is linked, through a buffer 13 if rate matching is necessary, to the input of a level selector 14, the output of which constitutes the output of the digital transmitter 11 of the digital adapter 5. This output of the digital transmitter 11 of the digital adapter 5 is connected, through the network 2, to the input of the receiving part of the analog adapter 6, which is represented at the upper part 15 of Figure 4, the transmission part of the analog adapter 6 being represented by the lower part 16 of Figure 4.

The receiver 15 of the analog adapter 6 receives, at its input, (at the top of Figure 4), a series of analog pulses the voltage levels of which represent the information transmitted by the digital adapter of Figure 3. The presence of filters in the telephone exchange 4 causes interference between the successive pulses. It is therefore difficult to recognize them and to measure their levels.

The receiver 15 of the analog adapter 6 receives, at its input, (at the top of Figure 4), a series of analog pulses the voltage levels of which represent the information transmitted by the digital adapter of Figure 3. The presence of filters in the telephone exchange 4 causes interference between the successive pulses. It is therefore difficult to recognize them and to measure their levels.

The analog receiver 15 of the invention which is illustrated in the upper part of Figure 4 consists of two main parts: an adaptive digital linear filter 17 which "equalizes" the signal, converting the distorted pulse originating from the network through a filter 18 and an analog/digital converter 19, into a well controlled pulse which introduces interference only between successive even (or odd) levels. For example, the output Y_n of the equalization filter 17 at time n is given by one of the expressions:

$$\begin{aligned}
 20 \quad & Y_n = X_n - X_{n-2} \text{ (class IV)} \\
 \text{OR:} \quad & Y_n = X_n - X_{n-1} - X_{n-2} + X_{n-3} \\
 \text{OR:} \quad & Y_n = X_n - 2X_{n-2} + X_{n-4}
 \end{aligned}$$

or by a similar expression determined adaptively, where the X_n are the levels sent by the digital adapter 5.

This equalization system is known per se as a "class IV partial response". The invention makes it possible to apply such a response to a situation of direct communications between a digital adapter 5 and an analog adapter 6.

In order to avoid error propagation to the receiver, the use of differential coding at 14 is recommended, as is well known per se.

Moreover, if the linear equalization filter 17 has to be adaptive, the choice thereof is within the scope of the person skilled in the art.

At this point, the interference between symbols, which is expressed by the relationship $Y_n =$

$X_n - X_{n-2}$ remains to be eliminated. To this end, two known techniques can be used: decision-feedback equalization (DFE) and the Viterbi algorithm, which are represented by the functional block 20.

5 The X_n levels produced by the telephone exchange
4 are not always equal to their nominal levels provided
by the quantization law. The analog receiver 15
therefore has to estimate the real value of the X_n and
these real values have to be used in the decision-
10 feedback equalizer, or the Viterbi equalizer 20. The
estimate can be made by using one of the variations of
the least-squares algorithm, implemented in a
functional block 21.

 It should be noted that the real values of the
15 X_n have also to be used in an echo canceler 22 of the
digital adapter (Figure 3). To this end, the digital
adapter 5 may itself also produce an estimate of the
real values with the aid of a functional block similar
to the block 21 of Figure 4, or else use corresponding
20 check information transmitted by the analog adapter 6.
The corresponding links are not represented in the
figures for simplicity.

 In the other data transmission direction, that is
to say from the analog adapter 6 to the digital adapter
25 5, the transmitter 16 of the analog adapter illustrated
at the bottom of Figure 4 uses the clock 23 of the
terminal 6, which it has recovered in its receiving
section 15. The purpose of the transmission part 16 of
the analog adapter 6 is to produce an analog signal
30 which, when it is sampled, will be equal to one of the
nominal levels of the quantization law, the level in
question being determined by the digital information
transmitted by the digital adapter 5.

 The ATT patent EP-0 669 740 and EURECOM patent FR
35 9512672 envisage that voltage values at the sampling
instants should be equal to one of the nominal levels
of the quantization law, with the drawbacks which stem
from this, as explained above. However, according to

the present invention, this limitation is not useful. This is because the echo of the signal produced by the digital adapter is added to the signal produced by the analog adapter, and shifts it in an unpredictable manner which is however known to the digital adapter, as described above. In the presence of an echo, the value of the signal at the moment of sampling could fall between two quantization levels, so that the noise would easily push it one side or the other.

10 It will be the role of the receiver of the digital adapter to retrieve the information from the quantized signal, and in this case it is worthwhile choosing values which make it possible to simplify the task of the receiver, for example by spacing the values apart in a different way from what would be permitted by the levels of the quantization law.

15 For example, it might be desired to send separate levels of 15 units, lying between -500 and +500 units. This would not be possible under the A law, in which the levels between -30 and +30 are separated by 2 units, those between 33 and 93 by 4 units, those between 99 and 219 by 8 units, etc.

25 The invention provides for the pulse response between the analog adapter 6 and the exchange 4 to be measured by the digital adapter 5, and communicated to the analog adapter 6 by check messages. On the basis of these measurements, the analog adapter 6 synthesizes a digital filter 24 so that the overall response (line 8 + filters) is again a partial response, for example a class IV partial response, in particular modified so as to provide further attenuation near 0 Hz, within the 0 to 60 Hz band, or near 4000 Hz. This attenuation could also be determined adaptively. This technique is called "predistortion". The filter 24 also has an ancillary role, that of producing a signal at a rate of 16 kHz, particularly from an 8 kHz input originating from the analog adapter 6, in order to facilitate the design of the analog filter 25 which follows the D/A converter

26, which produces an analog signal from a digital signal.

Thanks to the use of the predistortion filter 24, an equation of the type $Y_n = X_n - X_{n-2}$ (or some other) is again applicable, where Y_n this time designates the signal at the exchange 4 and X_n the output level of the analog transmitter 16. It is necessary for Y_n to correspond to one of the levels of the quantization law S_j so as to reduce the influence of noise. Consequently, the following relationship has to be satisfied:

$$X_n = X_{n-2} + S_j$$

If no precautions are taken, following this relationship may lead to over-large values for X_n . Numerous techniques, known by the name of "line coding" are available to resolve this problem, for example in the form of a line coder 27, in particular the known Tomlinson-Harashima method. At this point, the person skilled in the art can easily choose a particular one of them.

We saw above that the presence of the echo may render the signal very sensitive to noise. It is therefore vital to use an error correcting system, typically a treillis modulation code. The use of a convolutional code or a block code may also be envisaged.

At the exchange 4, the signal Y_n (corrupted by noise, as the case may be) is quantized and encoded into one byte which is transmitted to the receiving part 12 of the digital adapter 5, illustrated at the bottom of Figure 3. Here, the bytes are converted into linear levels by the linear conversion unit 28 (using conversion law A, for example).

The resultant signal, like the estimate of the echo of the signal transmitted by the digital transmitter 11, is then processed in the decoder

functional block 30. The purpose of this block is to estimate the information item transmitted by the analog adapter.

5 The linear signal is the quantization of the sum of the signals representing the digital information item transmitted by the analog adapter, the echo of the signal transmitted by the digital adapter and the noise. The presence of the quantization prevents elimination of the echo by subtraction, as in
10 conventional echo cancellers.

Unlike the Conventional method consisting in suppressing the echo by subtraction, followed by decoding of the useful signal, it is now necessary to deal jointly with the problems of echo compensation and
15 detection of the signal transmitted by the analog adapter.

In the case of trellis coded modulation, this functional block 30 may take the form of a Viterbi algorithm so as to find the most likely path within a
20 trellis diagram. The weights assigned to the branches in this diagram are the likelihood ratios of the quantized signals observed, given the estimated value of the echo and the assumption corresponding to the branch in question.

25 The output from the block 30 is transmitted, possibly across a buffer 31, to the user of the digital adapter 5.

As represented in Figure 3, the error signal (difference between the received signal and the ideal
30 signal) in the unit 30 of the Viterbi algorithm or of the decision-feedback system, is used in order to adapt the echo canceler 22, and to estimate the error due to incorrect synthesis of the predistortion filter 24 in the analog adapter 6. The correction information
35 (encoded at a low rate) is multiplexed in the level selector 14 with the information originating from the user connected to the input of the digital adapter 5 (service channel), and transmitted to the analog

adapter 6. It is used in the analog adapter in order to adapt the predistortion filter 24.

The analog adapter must also eliminate its own echo. The techniques to that effect are well known and an implementation is represented in Figure 4, in the form of an echo filter 22.

As represented in figure 4, the error signal in the unit 20 corresponding to the Viterbi algorithm or to the decision-feedback system is used by the adaptation algorithms 34 to adjust the echo filter 22', the adaptive linear equalizer 17 and the local clock 23.

It is obvious that, as in conventional modem communications, recognition and learning sequences have to be exchanged when communication is established. They serve to initialize the clocks and the adaptive filters. It is also necessary to check that one or other of the telephone exchanges 3,4 can use either the A law or the μ law, and adapt itself consequently.

It results from the foregoing that the invention achieves its objectives, and makes it possible to link a digital line to an analog line in order to send digital information, directly and economically, without having to emulate an analog signal. This makes it possible to transmit at a rate substantially equal to that of a relatively high-speed digital line, while using a normal telephone line for the transmission.

What is claimed is:

- 5 1. A hybrid device for data communication between a digital adapter and an analog adapter for transmitting and receiving digital and analog messages over a switched telephone network, said digital adapter coupled to a first exchange through a digital interface, said analog adapter coupled to a second exchange through an analog interface, said device, in the direction of transmission from said digital adapter to said analog adapter, comprising:
- 10 a transmitting component of said digital adapter for encoding a digital message containing user data into a stream of bytes;
transmitting said stream of bytes over said network,
at said analog interface, converting said stream of bytes into a plurality of analog pulses having amplitudes indicated by said bytes, and forming an analog signal;
- 15 a receiving component of said analog adapter for receiving said analog signal and producing a class IV partial response including a plurality of pulses with variable amplitudes and recovering said user data,
wherein analog-to-digital conversion and digital-to-analog conversion of information is performed based on a type "A" linear conversion rule, and wherein
20 the analog to digital conversion is not based on emulating the analog signal.
2. The device of claim 1, wherein said transmitting component of said digital adapter including an n-level selector for separating groups of "k" bits, each group forming one byte, associating each byte of a plurality of bytes with "n" nominal voltage levels pre-selected from "N" available voltage levels ($n < N$) such that
25 each voltage level is equal to the value of said byte.
3. The device of claim 2, wherein $k = 6$, $N = 64$, and $N = 256$.
- 30 4. The device of claim 1, wherein said receiving component of said analog adapter including,

an adaptive linear equalizer for receiving an analog resultant signal formed by said analog pulses distorted during transmission and producing a class IV partial response according to said type "A" linear conversion rule, said partial response including a plurality of pulses with variable amplitudes,

5 a level estimator for estimating the real digital values of said stream of bytes based on said amplitudes, and

an output equalizer for retrieving said digital message based on said real digital values.

10 5. A device according to claim 4, wherein said output equalizer is one of a decision feedback equalizer and a Viterbi equalizer.

6. The device of claim 1, wherein said network is an ISDN network and said exchange is an ISDN exchange.

15 7. A hybrid device for data communication between an analog adapter and a digital adapter for transmitting and receiving digital and analog messages over a switched telephone network,
said digital adapter coupled to a first exchange through a digital interface,
20 said analog adapter coupled to a second exchange through an analog interface,
said device, in the direction of transmission from said analog adapter to said digital adapter, comprising:

25 an analog transmitter in the analog adapter for synthesizing digital input data, outputting a class IV partial response, and further converting said partial response into a succession of analog pulses,

at said analog interface, sampling said analog pulses according to a type "A" linear conversion rule to generate a digital signal for transmission over said network,

30 a receiving component at said digital adapter for processing said digital signal and recovering said digital input data,

wherein analog-to-digital and digital-to-analog conversion of information is performed based on said type "A" linear conversion rule.

5 8. The device of claim 7, wherein said analog transmitter in said analog adapter including

a line coder and a predistortion filter for synthesizing said digital input data and outputting a class IV partial response, and

a D/A converter forming a succession of analog pulses,

10 said analog interface for receiving and sampling said analog pulses according to said type "A" linear conversion rule by dividing said stream in groups of "k" bits, each group of "k" bits forming one byte, and associating each byte with "n" nominal voltage levels pre-selected from "N" available voltage levels for generating a digital signal, and thereafter transmitting said digital signal over said network.

15 9. The device of claim 7, wherein said receiving component at said digital adapter including a law "A" to linear converter, an echo filter and a line decoder for decoding said digital signal and recovering said digital input data.

20 10. The device of claim 7, wherein said network is an ISDN network and said exchange is an ISDN exchange.

25 11. A method of data transmission between a digital adapter and an analog adapter over a telephone network, said digital adapter coupled to a first exchange through a digital interface, said analog adapter coupled to a second exchange through an analog interface, said method including the steps of:

at said digital adapter,

- receiving digital input data and dividing said digital input data into groups of information bits, each group forming a byte,

30

- using a type "A" linear conversion rule, associating each byte with one of "n" nominal voltage levels preselected from "N" available voltage levels ($n < N$), each voltage level with an amplitude equal to the value of said respective byte, so as to form a stream of bytes;

5 - transmitting said stream of bytes over said network;

at said analog interface

- processing said stream of bytes to generate an analog signal including analog pulses, each pulse having an amplitude substantially equal to said voltage level associated with each byte,

10 at said analog adapter,

- receiving a resultant analog signal, equalizing said resultant analog signal to eliminate interferences, and generating a class IV partial response;

- measuring amplitudes of equalized analog pulses forming said partial response and estimating the real digital value of each byte of said stream of bytes; and

15 - recovering said group of information bits based on said real digital value of said bytes.

12. A method of data transmission between an analog adapter and a digital adapter over a telephone network, said digital adapter coupled to a first exchange through a digital interface, said analog adapter coupled to a second exchange through an analog interface, said method including the steps of:

20 at said analog adapter,

25 - receiving input digital data, dividing said input digital data into groups of information bits, each group forming a byte, and synthesizing a plurality of bytes forming said input digital data into a class IV partial response;

- converting each said bytes into analog pulses with amplitudes indicated by the value of each byte, so as to form an analog signal;

at said analog interface

30 - sampling said analog signal using a type "A" linear conversion rule by associating each byte with one of "n" nominal voltage levels preselected from "N"

available voltage levels ($n < N$), each voltage level with an amplitude equal to the value of said respective byte, and forming a stream of bytes;

- successively transmitting said stream of bytes over said network;

at said digital adapter,

- 5 - receiving and processing said stream of bytes in said digital adapter using a type "A" linear conversion rule for retrieving said bytes having the most likely sequence of said information bits.

FIG. 1

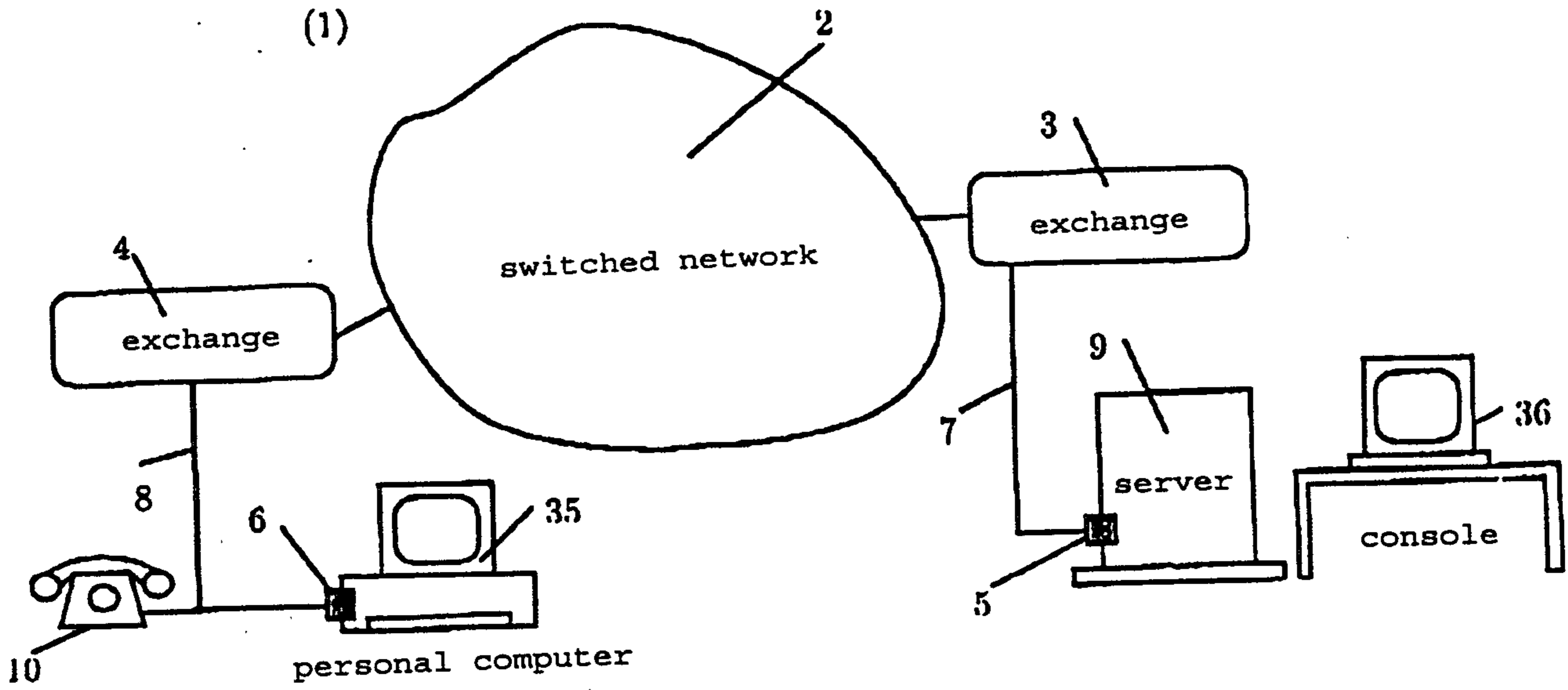
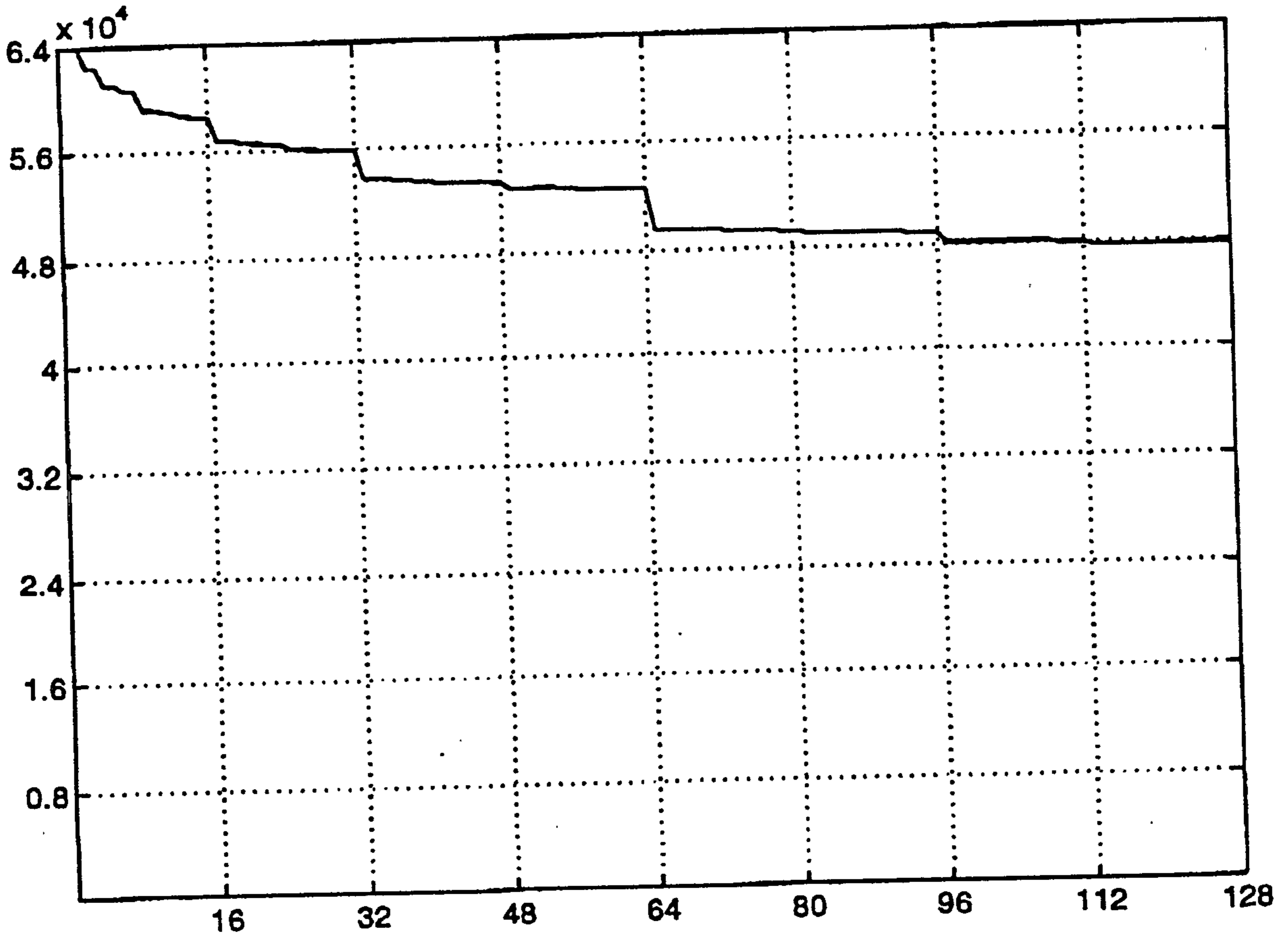

FIG. 2



2/3

FIG. 3

A - Digital adapter (5)

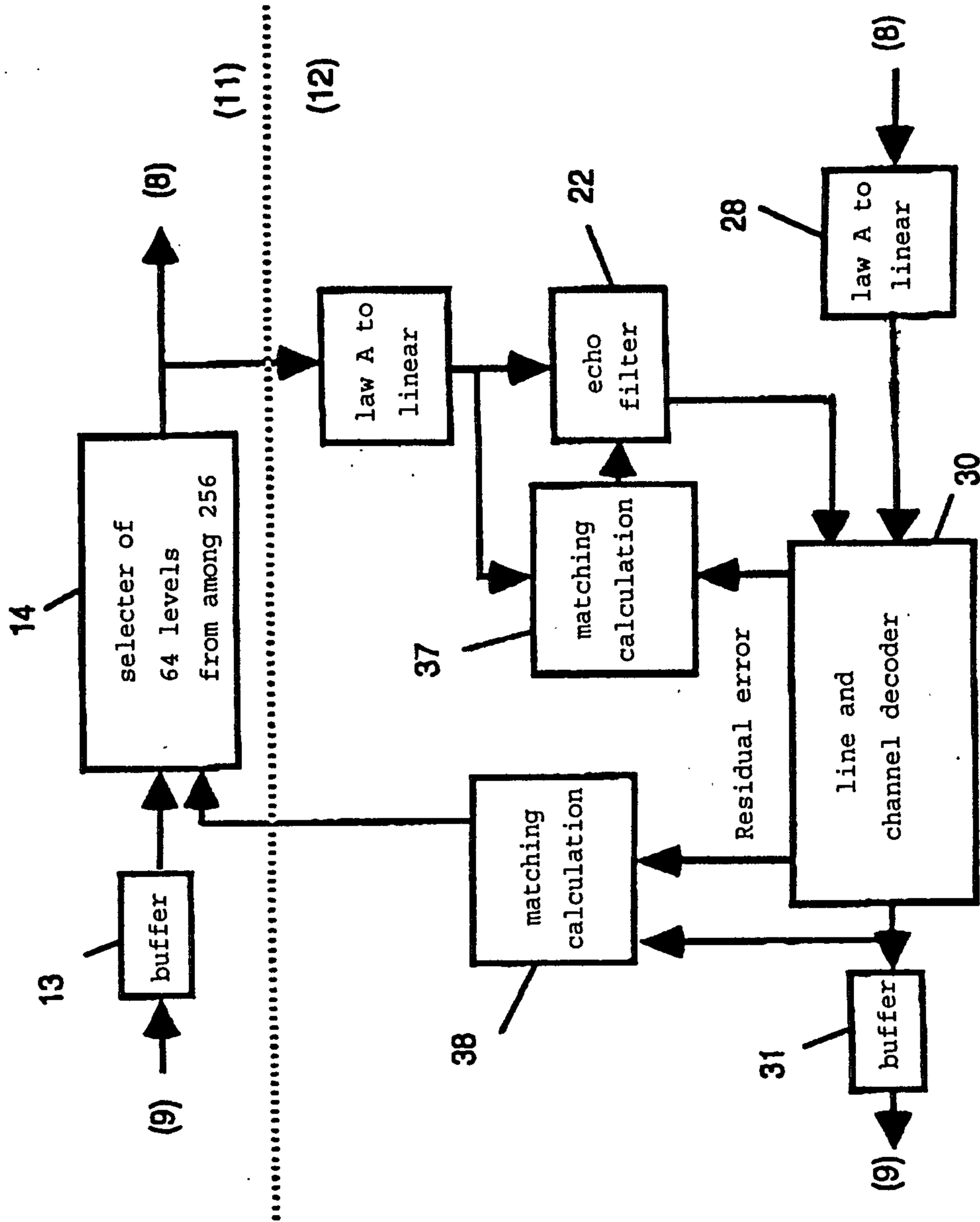

3/3

FIG. 4

Analog adapter (6)

