

(19) World Intellectual Property Organization  
International Bureau



(43) International Publication Date  
13 March 2003 (13.03.2003)

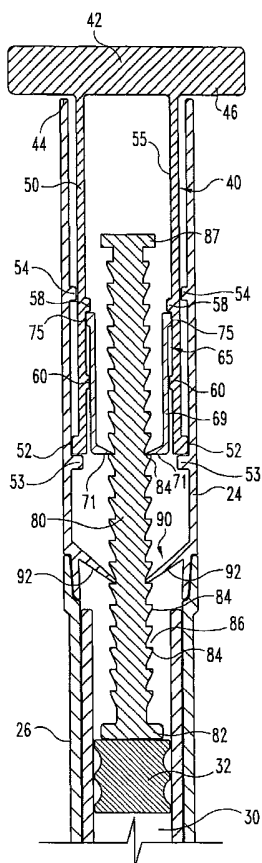
PCT

(10) International Publication Number  
WO 03/020347 A2

- (51) International Patent Classification<sup>7</sup>: A61M 5/00
- (21) International Application Number: PCT/US02/05114
- (22) International Filing Date: 15 March 2002 (15.03.2002)
- (25) Filing Language: English
- (26) Publication Language: English
- (30) Priority Data:  
60/279,070 27 March 2001 (27.03.2001) US
- (71) Applicant (for all designated States except US): ELI LILLY AND COMPANY [US/US]; Lilly Corporate Center, Indianapolis, IN 46285 (US).
- (72) Inventor; and
- (75) Inventor/Applicant (for US only): ROE, Michael, Joseph [US/US]; 10263 Oak Ridge Drive, Zionsville, IN 46077 (US).
- (74) Agent: PREIN, Edward, J.; Eli Lilly and Company, Lilly Corporate Center, Indianapolis, IN 46285 (US).
- (81) Designated States (national): AE, AG, AL, AM, AT (utility model), AT, AU, AZ, BA, BB, BG, BR, BY, BZ, CA, CH, CN, CO, CR, CU, CZ (utility model), CZ, DE (utility model), DE, DK (utility model), DK, DM, DZ, EC, EE (utility model), EE, ES, FI (utility model), FI, GB, GD, GE, GH, GM, HR, HU, ID, IL, IN, IS, JP, KE, KG, KP, KR, KZ, LC, LK, LR, LS, LT, LU, LV, MA, MD, MG, MK, MN, MW, MX, MZ, NO, NZ, OM, PH, PL, PT, RO, RU, SD, SE, SG, SI, SK (utility model), SK, SL, TJ, TM, TN, TR, TT, TZ, UA, UG, US, UZ, VN, YU, ZA, ZM, ZW.
- (84) Designated States (regional): ARIPO patent (GH, GM, KE, LS, MW, MZ, SD, SL, SZ, TZ, UG, ZM, ZW), Eurasian patent (AM, AZ, BY, KG, KZ, MD, RU, TJ, TM), European patent (AT, BE, CH, CY, DE, DK, ES, FI, FR, GB, GR, IE, IT, LU, MC, NL, PT, SE, TR), OAPI patent

[Continued on next page]

(54) Title: MEDICATION DISPENSING APPARATUS CONFIGURED FOR PULL TO SET DOSE AND PUSH TO INJECT SET DOSE FUNCTIONALITY



(57) Abstract: A medication dispensing apparatus in which a dose is set by pulling out an actuator, and then dispensed by pushing in that actuator. In one form, the apparatus is an injector pen with a housing that holds a medicine-filled cartridge. A drive member that engages a plunger of the cartridge axially extends within the housing. An anti-backup member operably engages the drive member to permit forward movement and prevent rearward movement of the drive member within the housing. An actuator axially movable into and out of the housing includes a manually graspable grip portion. When the actuator is moved from a forward position to a rearward position by pulling on the grip portion, a clutch element moves rearward relative to the drive member held by the anti-backup member. When the actuator is subsequently moved from the rearward position to the forward position, the clutch element is moved forward, and due to a catch portion of the clutch element fitting within an indentation of the drive member, the drive member is also moved forward to advance the plunger to force medicine from the cartridge.

WO 03/020347 A2



(BF, BJ, CF, CG, CI, CM, GA, GN, GQ, GW, ML, MR, NE, SN, TD, TG).

**Declarations under Rule 4.17:**

- *as to applicant's entitlement to apply for and be granted a patent (Rule 4.17(ii)) for the following designations AE, AG, AL, AM, AT, AU, AZ, BA, BB, BG, BR, BY, BZ, CA, CH, CN, CO, CR, CU, CZ, DE, DK, DM, DZ, EC, EE, ES, FI, GB, GD, GE, GH, GM, HR, HU, ID, IL, IN, IS, JP, KE, KG, KP, KR, KZ, LC, LK, LR, LS, LT, LU, LV, MA, MD, MG, MK, MN, MW, MX, MZ, NO, NZ, OM, PH, PL, PT, RO, RU, SD, SE, SG, SI, SK, SL, TJ, TM, TN, TR, TT, TZ, UA, UG, UZ, VN, YU, ZA, ZM, ZW, ARIPO patent (GH, GM, KE, LS, MW, MZ, SD, SL, SZ, TZ, UG, ZM, ZW), Eurasian patent (AM, AZ, BY, KG, KZ, MD, RU, TJ, TM), European patent (AT, BE, CH, CY, DE, DK, ES, FI, FR, GB, GR, IE, IT, LU, MC, NL, PT, SE, TR), OAPI patent (BF, BJ, CF, CG, CI, CM, GA, GN, GQ, GW, ML, MR, NE, SN, TD, TG)*
- *as to the applicant's entitlement to claim the priority of the earlier application (Rule 4.17(iii)) for the following designations AE, AG, AL, AM, AT, AU, AZ, BA, BB, BG, BR, BY,*

*BZ, CA, CH, CN, CO, CR, CU, CZ, DE, DK, DM, DZ, EC, EE, ES, FI, GB, GD, GE, GH, GM, HR, HU, ID, IL, IN, IS, JP, KE, KG, KP, KR, KZ, LC, LK, LR, LS, LT, LU, LV, MA, MD, MG, MK, MN, MW, MX, MZ, NO, NZ, OM, PH, PL, PT, RO, RU, SD, SE, SG, SI, SK, SL, TJ, TM, TN, TR, TT, TZ, UA, UG, UZ, VN, YU, ZA, ZM, ZW, ARIPO patent (GH, GM, KE, LS, MW, MZ, SD, SL, SZ, TZ, UG, ZM, ZW), Eurasian patent (AM, AZ, BY, KG, KZ, MD, RU, TJ, TM), European patent (AT, BE, CH, CY, DE, DK, ES, FI, FR, GB, GR, IE, IT, LU, MC, NL, PT, SE, TR), OAPI patent (BF, BJ, CF, CG, CI, CM, GA, GN, GQ, GW, ML, MR, NE, SN, TD, TG)*

**Published:**

- *without international search report and to be republished upon receipt of that report*

*For two-letter codes and other abbreviations, refer to the "Guidance Notes on Codes and Abbreviations" appearing at the beginning of each regular issue of the PCT Gazette.*

-1-

**MEDICATION DISPENSING APPARATUS CONFIGURED FOR PULL TO SET  
DOSE AND PUSH TO INJECT SET DOSE FUNCTIONALITY**

**BACKGROUND OF THE INVENTION**

5           The present invention pertains to medication dispensing devices, and, in particular, to a portable medication dispensing device such as an injector pen.

          Patients suffering from a number of different diseases frequently must inject themselves with medication. To allow a person to conveniently and accurately self-administer proper doses of medicine, a variety of devices broadly known as injector pens  
10       have been developed.

          In order to permit a person to administer a proper dose, injector pens have been equipped with a wide variety of dosing and injecting mechanisms that enable a dosage to be conveniently selected and then dispensed. Generally, these pens are equipped with a cartridge including a plunger and containing a multi-dose quantity of liquid medication.  
15       A drive member, extending from within a base of the injector pen and operably connected with typically more rearward portions of the dosing and injecting mechanisms, is movable forward to advance the plunger in the cartridge in such a manner to dispense the contained medication from the opposite cartridge end, typically through a needle that penetrates a stopper at that opposite end. In disposable pens, after a pen has been utilized to exhaust  
20       the supply of medication within the cartridge, the entire pen is discarded by a user, who then begins using a new, replacement pen.

          One problem with some existing injector pens is that dosing and injecting operations of the pen are not intuitive to all users. In particular, typically the user first must rotate a knob piece of the pen to set the medicine dose to be delivered, and then  
25       must apply an axial or plunging force which moves the knob piece axially to inject the medicine dose. Because for many pen designs the knob piece will have axially translated

-2-

away from the pen base while being rotated during dose setting, and further that knob piece, when plunged during injecting, will also rotate back into the pen base, a user may come to believe that rotating down the extended set knob will inject the medicine.

5 However, such a belief is erroneous for at least some pen designs, and therefore a user who operates under such an erroneous belief may not properly self-administer the desired medicine.

One known pull and inject type injection device is disclosed in U.S. Patent No. 6,048,336. The disclosed pen can be prepared to deliver a preselected set dose by axially pulling an end member away from the remainder of the pen base until a stop is reached.  
10 Then, when the end member is plunged or axially driven fully back toward the pen, an internal plunger-engaging member is advanced to dispense or inject that set dose from a needle equipped cartridge of the pen. The preselected set dose is adjustable prior to the pull and inject process by a rotatable dosing element. While useful, this known device is not without its shortcomings. For one thing, the adjustability in the preselecting of the set  
15 dose comes at the price of increasing the overall complexity of the pen design, and further is a potential source of dosing errors for a user who fails to pay proper attention to the previously preselected dose. Furthermore, the pen utilizes a coiled spring to maintain the plunger-engaging member in a proper orientation during use, which spring complicates the pen design.

20 Thus, it would be desirable to provide an apparatus which overcomes these and other shortcomings of the prior art.

### BRIEF SUMMARY OF THE INVENTION

In one form thereof, the present invention provides a medication dispensing  
25 apparatus including a housing, a fluid container, a plunger drive member, at least one anti-backup member, an actuator, and at least one clutch element. The fluid container is mounted to the housing and defines a medicine-filled reservoir with a movable plunger at one end and an outlet at the other end. The plunger drive member axially extends within the housing and includes a series of longitudinally spaced indentations and a forward end  
30 that operably engages the movable plunger. The at least one anti-backup member operably engages the drive member to permit forward movement and prevent rearward movement of the drive member within the housing. The actuator is axially movable into

-3-

and out of the housing between a forward position and a rearward position, and includes a manually graspable grip portion which is pullable rearwardly to move the actuator from the forward position to the rearward position. The at least one clutch element is axially movable relative to the actuator and operably associated with the actuator to be movable  
5 between first and second positions when the actuator is moved between the forward and rearward positions. The clutch element is structured to axially move rearward relative to the drive member held by the at least one anti-backup member when the at least one clutch element is moved from the first position to the second position, and to have a catch portion within one of the indentations of the drive member and axially move forward the  
10 drive member when the at least one clutch element is moved from the second position to the first position to thereby advance the plunger to force medicine from the reservoir through the outlet.

In another form thereof, the present invention provides a medication injector pen including a housing, a cartridge within the housing, which cartridge defines a medicine-  
15 filled reservoir with a movable plunger at one end and an outlet at the other end, a plunger drive member axially extending within the housing and including a first end adapted to operably engage the movable plunger, and means for preventing the drive member from moving rearwardly within the housing. The pen also includes an actuator including a grip portion and a body portion. The grip portion is disposed rearward of the housing, and the  
20 body portion is disposed forward of the grip portion and extends within the housing. Application of a pulling force on the grip portion moves the actuator such that the body portion axially moves within the housing from a forward position to a rearward position. Application of a pushing force on the grip portion moves the actuator such that the body portion axially moves within the housing from the rearward position to the forward  
25 position. The pen includes a connecting means between the actuator body portion and the drive member for not axially moving the drive member when the actuator body portion axially moves within the housing from the forward position to the rearward position, and for axially moving the drive member forward when the actuator body portion axially moves within the housing from the rearward position to the forward position to thereby  
30 advance the plunger to force medicine from the reservoir through the outlet.

One advantage of the present invention is that an injector pen is provided which is simple to operate.

-4-

Another advantage of the present invention is that an injector pen is provided which is structured to have pull to set dose and push to inject set dose functionality.

Another advantage of the present invention is that an injector pen is provided which in one form does not require for dosing purposes any numerals readable by a user.

5 Still another advantage of the present invention is that an injector pen is provided having a readily visible indication of proper dose delivery.

Yet another advantage of the present invention is that an injector pen is provided which eliminates any rotatable dose selecting element which could be moved prior to injection to cause an incorrect dose to be delivered.

10

### **BRIEF DESCRIPTION OF THE DRAWINGS**

The above-mentioned and other advantages and objects of this invention, and the manner of attaining them, will become more apparent, and the invention itself will be better understood by reference to the following description of embodiments of the invention taking in conjunction with the accompanying drawings, wherein:

15

Fig. 1 is a diagrammatic front view of a first embodiment of a medication injector pen with a pull to set and push to inject delivery mechanism of the present invention;

Fig. 2 is a fragmentary, diagrammatic cross-sectional view of rearward portions of the injector pen of Fig. 1;

20

Fig. 3 is a front view of one embodiment of a clutch removed from the remainder of the injector pen of Fig. 2; and

Figs. 4, 5, 6 and 7 are fragmentary, diagrammatic cross-sectional views illustrating the configuration of components of the injector pen of Fig. 1 during different phases of the dose setting and injecting process.

25

Corresponding reference characters indicate corresponding parts throughout the several views. Although the drawings represent an embodiment of the present invention, the drawings are not necessarily to scale, and certain features may be exaggerated or omitted in some of the drawings in order to better illustrate and explain the present invention.

30

### **DETAILED DESCRIPTION OF THE INVENTION**

Referring now to Fig. 1, there is diagrammatically shown an exemplary embodiment of a medication dispensing device with pull to set dose, push to inject set

-5-

dose functionality of the present invention. The device is a medication injector pen, generally designated 20, which includes an external housing 22 assembled together from multiple molded plastic components. The upper or rearward portion 24 of housing 22, which can be assembled from two mating halves welded together, contains the dosing and injecting related components of pen 20. The lower or forward portion 26 of housing 22, which can be fixedly attached to upper portion 24 via adhesives or ultrasonic welding, holds a medication filled cartridge outlined at 28 in Fig. 1. As further shown in Fig. 2, and as is conventional, cartridge 28 defines a medicine-filled reservoir 30 which is closed at its distal end by plunger 32 that is slidably and sealably engaged with the cartridge interior wall. The outlet end of cartridge reservoir 30 is sealed by a not shown stopper which is penetrable by a needle of injection needle assembly 34 which is removably mounted, such as via a screw engagement, to the proximal end of housing portion 26. The shown housing configuration is illustrative and not intended to be limiting as other housing constructions may be employed within the scope of the invention. For example, rather than having a distinct cartridge held within the housing, the cartridge features could be integrated into a housing portion attachable to a rearward housing portion.

With additional reference to Figs. 2 and 3, injector pen 20 includes an actuator member, generally designated 40, which is respectively pulled and pushed by a user relative to housing portion 24 during the process of setting a dose and injecting the set dose. Actuator member 40 includes a grip portion 42 that extends rearward beyond distal end 44 of housing portion 24. The peripheral region 46 of grip portion 42 which juts radially outward beyond the housing periphery permits grip portion 42 to be readily grasped by hand by a user and pulled upward from the perspective of a viewer of the Figures. Other graspable grip portion configurations may be substituted, such as a button with concave sides in which fingertips can fit, or a loop in which a finger can insert.

A body portion 50 of actuator member 40 projects from grip portion 42. Body portion 50 is preferably a cylindrical tube that is shaped complementary to the interior hollow of rearward housing portion 24, and is slidable out of and into housing portion 24 during dose setting and injecting operations. Body portion 50 is preferably rotatable or free wheeling within housing portion 24.

The exterior periphery of body portion 50 is preferably provided with information visible through viewing window 27 to aid a user in properly using pen 20. For example,

-6-

information such as colored bands, which encircle body portion 50 completely if actuator 40 is freewheeling within the housing, are positioned on different axial regions of body portion 50. One color, such as green, would be visible when the actuator member 40 has been fully pulled out and the pen is ready for injection. Another color, such as red, would be visible when the actuator member 40 has not been pulled out sufficiently far for injecting, and even a third color could be used to indicate that actuator member 40 has been pulled out sufficiently far for pen priming, but not for injecting. In other embodiments, other forms of information, such as written indicia including numbers or letters or lines that align with indicia on the pen housing, may be used, including at intermediate axial positions on body portion 50 to aid in the priming process. A magnifying lens is preferably positioned over window 27 to make easier the reading of information.

At its proximal, forward end, actuator body portion 50 includes a radially outwardly projecting stop 52. To prevent actuator member 40 from being fully extracted from the housing when pulled upward, stop 52 is sized to abut a complementary stop 54 that projects radially inward from, and is integrally formed with, an interior surface of housing portion 24. Each of stops 52 and 54 is preferably a continuous, circumferential ridge. However, alternate stop constructions, such as gaps in one or more of the ridges, or one of the ridges being replaced with one or more detents, may be provided as long as the ability to retain the actuator member is not compromised.

To control how far actuator member 40 can be moved into the housing when pushed downward, a stop 53 similar to stop 54 radially inwardly projects from the interior surface of housing portion 24 and is adapted to be abutted by the forward face of actuator stop 52 when the pen is arranged as is shown in Figs. 1 and 2. Stop 53 is also preferably a continuous, circumferential ridge.

The cylindrical inner surface 55 of body portion 50 is integrally provided with axially spaced, and similarly sized and shaped, clutch stops 58 and 60. Stops 58, 60 project radially inward and are each preferably formed as a continuous, circumferential ridge.

Clutch stops 58 and 60 serve to axially retain a clutch, generally designated 65, used to selectively transmit motion of actuator member 40 to drive member 80. As further shown in Fig. 3, in one embodiment clutch 65 is made from a resilient material

-7-

such as plastic and includes a cylindrical sleeve shaped body 67. The forward end of clutch body 67 is notched at four places to define four prongs 69. A catch or tooth 71 used to mesh with the serrated periphery of drive member 80 extends radially inward from each of prongs 69 at its proximal end. All of teeth 71 are located at the same axial position, but different axial positions may be provided depending on the configuration of drive member 80. Although in the shown embodiment four prongs evenly angularly spaced around the clutch circumference are used, in alternate embodiments, and depending on the construction of the drive member, fewer toothed clutch prongs, and in particular as few as one, but preferably at least two diametrically opposed prongs, may be provided. In addition, toothed clutch prongs in excess of the four shown may be employed.

Proximate its rearward end, clutch body 67 is provided with a pair of diametrically opposed, radially outwardly protruding stops or ridges 75. Ridges 75 abut clutch stops 58 and 60 to limit axial movement of clutch 65 relative to actuator member 40. A pair of diametrically opposed notches 76 in the body rearward end allow slight radially inward movement of ridges 75 to allow clutch 65 to be inserted within actuator member 40 during the pen assembly process.

Drive member 80 serves as a piston rod that longitudinally extends within housing 22. The forward end of drive member 80 terminates in an enlarged surface area 82 that contacts and thereby directly engages plunger 32. The outer periphery of drive member 80 has a series of evenly axially spaced teeth 84 extending along the length of the drive member. In the shown embodiment, teeth 84 are formed by ring-shaped ramps which each lie in a plane transverse to the axial length of the drive member 80. The radial drop off between the axial end of one ramped tooth 84 and the start of the next tooth 84 forms an indentation 86 in which clutch teeth 71 are insertable. Teeth 84 are of exaggerated size in the figures to facilitate illustration. A preferred axial length of each tooth, which equals the smallest controlled movement of the drive member in the shown embodiment, is a function of the fixed dose, and specifically a one tooth length movement of the drive member results in the discharge of a volume which is divisible without remainder into the fixed dose of the pen.

Drive member 80 can be otherwise formed within the scope of the invention. For example, the transversely arranged rings of ratchet teeth 84 mesh with all of the clutch

-8-

teeth 71 for any orientation to which clutch 65 has rotated relative to drive member 80. In an alternate embodiment in which the clutch is rotatably fixed, such as by keying, to the drive member, the drive member only needs teeth at the circumferential locations at which it is engaged with the one or more clutch teeth. In still another alternate embodiment in which the clutch is rotatably fixed to the drive member, the peripheral teeth of drive member 84 can be configured as one or more spiraling threads, and the height and orientation of the clutch teeth 71 can differ between clutch prongs such that each clutch tooth fits within an indentation between thread passes.

An anti-back up device 90 is positioned within housing 22 forward of clutch 65. Anti-back up device 90 functions to prevent drive member 80 from moving rearward into the housing, thereby assuring that surface area 82 of drive member 80 remains in contact with plunger 32 at all times, while serving to guide forward axial movement of the drive member. Anti-back up device 90 is shown formed from a pair of diametrically opposed, angled tangs 92 that extend from housing portion 24 into an indentation 86 to engage the ratchet teeth. Tangs 92 are sufficiently flexible to bend down and out when drive member 80 is advanced forward, but too rigid to bend up to allow rearward drive member movement.

In alternate embodiments the anti-back up device may be differently formed. For example, fewer or additional tangs, such as four, may be employed. Alternatively, rather than the teeth 84 engaged by clutch 65, and provided the device and the drive member were rotatably fixed, a different set of longitudinally extending teeth on the drive member could be engaged by the one or more tangs. Still further, the anti-back up device may be tied to housing portion 26.

Pen 20 also may be provided with structure to facilitate its priming by assisting with moving actuator member 40 in a partial stroke to move plunger 32 a small amount prior to injecting use of the pen. For example, in addition to and axially between stops 53 and 54, the interior surface of housing portion 24 may be formed with a not shown detent, or set of closely axially spaced detents, for priming purposes. The priming detent is adapted to engage stop 52 during a relatively early point in actuator member 40 withdrawal at which clutch 65 has been moved only a short distance, such as one tooth. The priming detent alternatively could engage a different protrusion of actuator member 40. The priming detent only offers increased resistance to further axial withdrawal, as

-9-

opposed to halting withdrawal of member 40 as does stop 54. Stop 52 can ride over the priming detent with application of sufficient axial force. The increased resistance offered by the priming detent creates a tactile, as well as possibly an audible, indication to a user of a pen arrangement at which plunging the actuator member will advance drive member 80 a small distance to achieve priming of the pen.

The structure of injector pen 20 will be further understood in view of the following explanation of its operation. Initially, a user requiring a dose of medication will locate pen 20, which normally will be in the arrangement shown in Fig. 1, which is the arrangement in which it remained after its previous use, or in which it is provided to a user for its first use.

Pen 20 should first be primed, which priming step will be described but briefly as the internal workings of the pen during this operation will be appreciated from the further explanation below with respect to its injecting operation. In particular, while holding housing 22 in one hand, the user will grasp actuator grip portion 42, such as by wrapping her fingers under the underside of overhang region 46 referenced in Fig. 2, and then begin a controlled pull of grip portion 42 axially rearward from the housing, or upward from the perspective of the Fig. 1 viewer. A user stops pulling when a priming indicator is visible through window 27, and/or she feels a noticeable resistance caused by mechanical engagement with the priming detent. Then, the user applies a plunging force on grip portion 42 to drive it downward to the arrangement shown in Fig. 1, during which plunging action the plunger 32 is shifted forward within cartridge 28. If a user sees that the plunger movement has caused liquid to reach the end of needle assembly 34, the priming process is complete. If no liquid is visible at needle assembly 34, the priming steps are repeated as needed.

After priming, the pulling step is performed to prepare pen 20 to deliver the dose for which it has been designed. Actuator grip portion 42 is first pulled axially rearward from the housing. At the start of this pulling phase, actuator member 40 initially will be withdrawn from within rearward housing portion 24 without axial movement of clutch 65 until stop member 60 abuts the underside of stop ridge 75 of the clutch mechanism, which arrangement is shown in Fig.4.

As pulling continues to move actuator member 40 upward, clutch 65 is pulled upward with the actuator member, during which movement the forward ends of the

-10-

resilient clutch body prongs 69 first flex or bend radially outward as prong teeth 71 slide up the ramped surface of a tooth 84, then snap back inward as teeth 71 slip into the adjacent indentation 86, and then repeat the process for successive teeth 84. It will be appreciated that the axial withdrawal of actuator member 40 prior to the movement of clutch 65 removes body portion 50 from a position radially outward of clutch teeth 71 so as to not prevent the flexing outward of the clutch prongs. Drive member 80 is prevented by anti-back up device 90 from being pulled upward within housing 22 during this clutch movement. Fig. 5 illustrates this prong flexing outward process at a point during movement from the arrangement shown in Fig. 4 after which multiple teeth 84 have been ratcheted over by the clutch.

The dose setting axial retraction of actuator member 40, and simultaneous axial movement of clutch 65, is completed when stop 52 abuts the underside of housing stop 54, and immediately before such abutting the clutch teeth 71 have slipped into an indentation 86. At this time, pen 20 has been prepared or set to deliver the medicine dose it was designed to inject, and is arranged as is shown in Fig. 6. In this arrangement, visible through viewing window 27 is information, such as a colored stripe, notifying the user that the actuator member 40 has in fact been fully pulled out, and that the pen is ready for injecting.

To start the injection, after pen 20 is manipulated so the injection needle of assembly 47 properly penetrates a user's skin, or other injection site, an axial plunging force is applied to grip portion 42 to move actuator member 40 back into the pen housing. Initially during its plunging, actuator member 40 moves downward without a corresponding movement in clutch 65, as no downward force is transferred onto clutch 65 which slides freely within the hollow of the actuator body. Thus, initially the drive member 80 is not advanced and no medication is expelled from pen 20. As plunging continues, the underside of stop 58 abuts the upper faces of ridge 75, at which time pen 20 is arranged as shown in Fig. 7. Body portion 50 is now positioned radially outward of, but in close spaced relationship with, clutch prongs 69 so as to prevent the prongs from being forced outward sufficiently to allow clutch teeth 71 to radially clear drive member teeth 84, and thus the clutch teeth can not skip over the ratchet teeth of the drive member as the clutch is subsequently moved forward. As plunging continues further and actuator member 40 is driven downward, clutch 65 is also driven downward. Due to the clutch

-11-

teeth 71, radially backed up by body portion 50, abutting the axial end face of a drive member tooth 84, drive member 80 is driven downward by clutch 65 through anti-backup device 90 to advance plunger 32 axially forward within cartridge 28 so as to expel medicine from the outlet end of the cartridge through needle assembly 34. Plunging motion of actuator member 40 is stopped, and the medicine injection is complete, when the forward face of actuator stop 52 abuts the end stop 53.

Pen 20 can continue to be used until the medicine remaining in the cartridge is insufficient for a proper dosing. In a preferred embodiment, this is signaled when the axial withdrawal of actuator member 40 during the pulling of grip portion 42 results in clutch teeth 71 abutting the underside of enlarged head 87 formed as the rearward end of drive member 80. Although sized to slide within the interior hollow of clutch 65, drive member head 87 is not passable by the clutch teeth, and therefore, further axial withdrawal of the clutch and actuator member is prevented. Due to the fact that a user will be unable to axially withdraw the actuator member 40 far enough for an indication of full dosing to be visible through view window 27, the user will understand that the pen has insufficient medicine remaining in the cartridge reservoir for proper dosage. In alternate embodiments, the clutch and/or drive member may be differently configured to have different portions abut each other to halt relative axial movement at the end of the pen use. When insufficient medicine remains, pen 20 is to be disposed of and replaced with a similar but entirely new pen.

The dose setting of pen 20 is preset at the factory, and therefore pen 20 is particularly adapted to deliver a single set dose for each complete axial withdrawal and then plunging of the actuator member. However, by modifying during pen manufacture the locations of one or more of the various stops that control the amount of axial motion possible between the clutch, actuator member and housing, different pens can each be provided with a different, individual dose setting. For example, without changing the design of clutch 65 and actuator member 40, by moving the axial location at which stops 54 are molded into housing portion 24, the set dose can be altered.

The instant invention will find particularly beneficial application in delivering medicines in which the necessary dose is the preset dose of the pen, or a small multiple of that preset dose. For example, if the necessary dose is twenty units, to deliver that dose an inventive pen having a preset dose of twenty units can be used once, or an inventive pen

-12-

having a preset dose of ten units can be used twice. Moreover, if delivering an excess of medicine is not medically problematic, such as in the case of a type of diabetes medicine known as glucagon like peptide-1(7-37), including analogs and derivatives thereof such as Val<sup>8</sup>GLP-1(7-37)OH, the use of the pen multiple times can introduce slightly more than the desired dose. For example, in the case of a medicine having two normal dosage amounts, such as eighteen units and fifty units, a single inventive pen adapted to dispense eighteen units for each pull and inject cycle may be used to deliver both dosage amounts. Specifically, a single complete axial withdrawal and then plunging of the actuator member can be used to deliver eighteen units, while a series of three complete axial withdrawals and then plungings of the actuator member can be used to deliver fifty-four units, which is slightly greater than the needed fifty units.

While this invention has been shown and described as having preferred designs, the present invention may be modified within the spirit and scope of this disclosure. For example, the clutch prongs could be constructed to shift the clutch teeth outward to a point clear of the drive member teeth when the actuator is withdrawn, and for such a configuration the actuator body portion, when plunged, would be designed to cam the prongs inward such that the clutch teeth engage the drive member teeth. In another embodiment, and although less desirable as the toothed engagement with the drive member may be less secure, the separate clutch may be eliminated, and one or more clutch prongs each with a tooth which is movable rearward along the drive member but not movable forward along the drive member may be incorporated directly into the body portion of the actuator member. This application is therefore intended to cover any variations, uses or adaptations of the invention using its general principles. Further, this application is intended to cover such departures from the present disclosure as come within known or customary practice in the art to which this invention pertains.

-13-

## CLAIMS

I CLAIM:

1. A medication dispensing apparatus comprising:  
a housing;

5 a fluid container mounted to the housing, said container defining a medicine-filled reservoir with a movable plunger at one end and an outlet at the other end;

a plunger drive member axially extending within said housing and including a series of longitudinally spaced indentations, said plunger drive member including a forward end operably engaging said movable plunger;

10 at least one anti-backup member operably engaging said drive member to permit forward movement and prevent rearward movement of said drive member within said housing;

an actuator axially movable into and out of said housing between a forward position and a rearward position, said actuator including a manually graspable grip  
15 portion which is pullable rearwardly to move said actuator from said forward position to said rearward position; and

at least one clutch element axially movable relative to said actuator and operably associated with said actuator to be movable between first and second positions when said actuator is moved between said forward and rearward positions, wherein said at least one  
20 clutch element is structured to axially move rearward relative to said drive member held by said at least one anti-backup member when said at least one clutch element is moved from said first position to said second position, and wherein said at least one clutch element is structured to have a catch portion within one of said indentations of said drive member and axially move forward said drive member when said at least one clutch  
25 element is moved from said second position to said first position to thereby advance said plunger to force medicine from said reservoir through said outlet.

2. The medication dispensing apparatus of claim 1 wherein said at least one clutch element comprises a plurality of prong portions each including a radially inwardly  
30 projecting catch portion.

-14-

3. The medication dispensing apparatus of claim 2 wherein said plurality of prong portions are resiliently bendable radially outward to allow said catch portions to slide over teeth of said drive member that define said indentations when said at least one clutch element is moved from said first position to said second position.

5

4. The medication dispensing apparatus of claim 3 wherein during movement of said actuator from said rearward position to said forward position, a portion of said actuator is moved into a position radially outward of said plurality of prong portions to prevent the prong portions from bending outward to allow said catch portions to radially clear drive member teeth.

10

5. The medication dispensing apparatus of claim 2 wherein said actuator and said at least one clutch element comprise abutting stop means for limiting forward and rearward travel during said relative axial motion.

15

6. The medication dispensing apparatus of claim 1 wherein said at least one clutch element comprises a plurality of catch portions angularly spaced around a circumference of said plunger drive member.

20

7. The medication dispensing apparatus of claim 1 wherein a rearward end of said plunger drive member has an enlarged head over which said at least one clutch element is not axially passable, whereby engagement of said at least one clutch element with said enlarged head provides an indication to a user of insufficient medicine remaining in said reservoir.

25

8. A medication injector pen comprising:

a housing;

a cartridge within said housing, said cartridge defining a medicine-filled reservoir with a movable plunger at one end and an outlet at the other end;

30

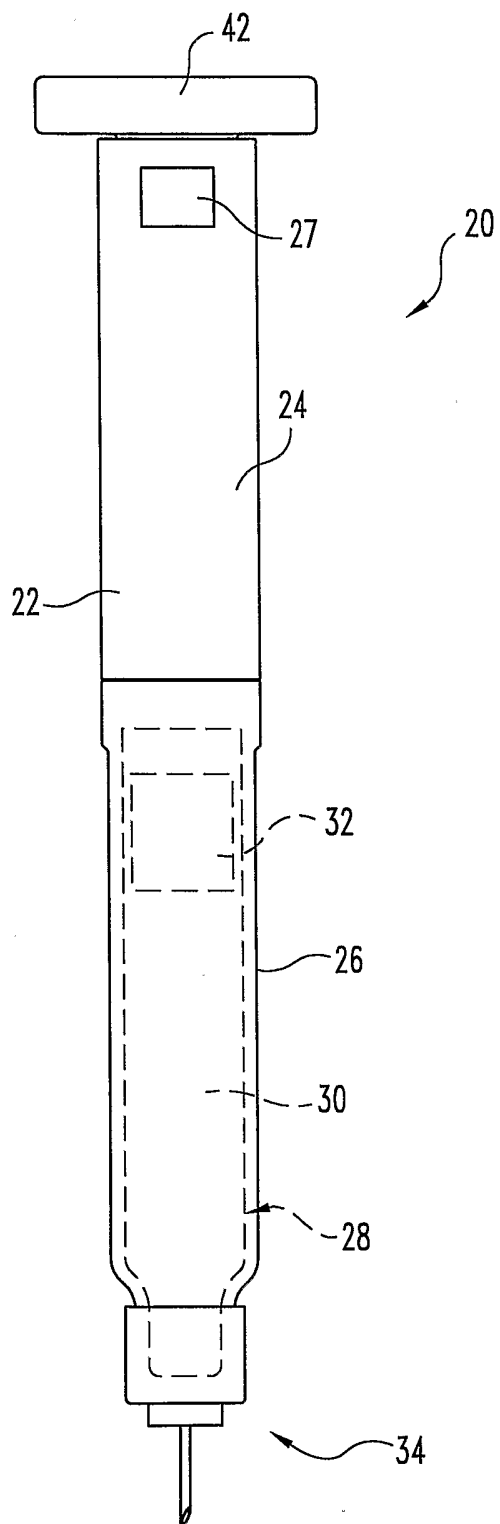
a plunger drive member axially extending within said housing and including a first end adapted to operably engage said movable plunger;

-15-

means for preventing said drive member from moving rearwardly within said housing;

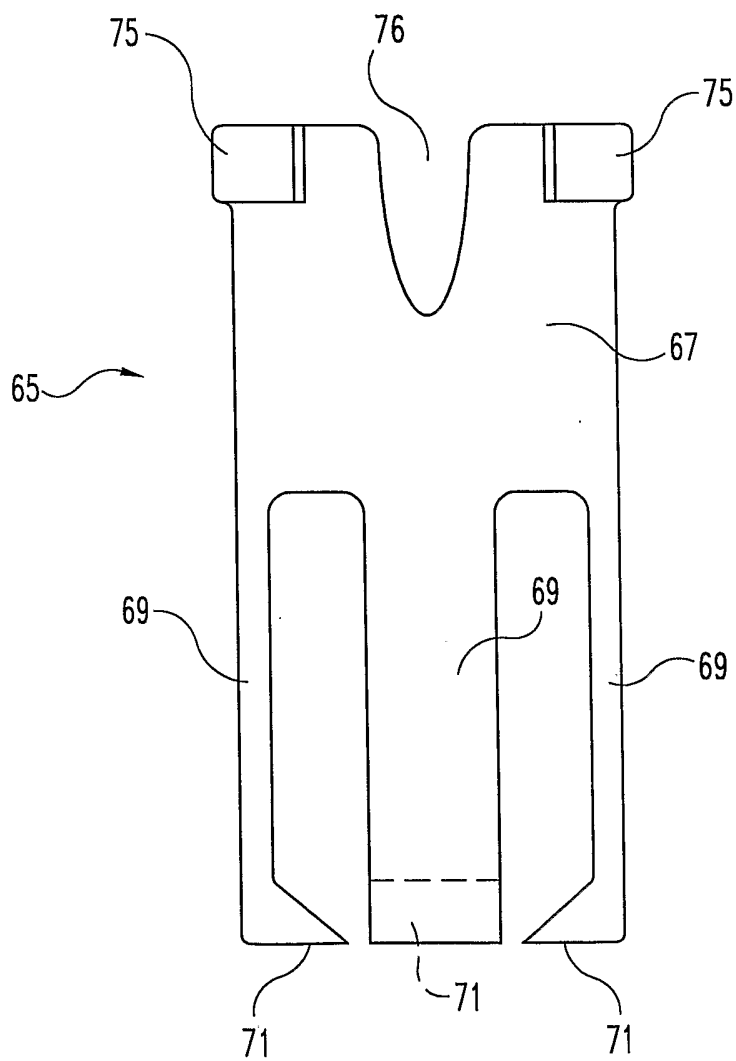
an actuator including a grip portion and a body portion, said grip portion disposed rearward of said housing, said body portion disposed forward of said grip portion and extending within said housing, wherein application of a pulling force on said grip portion moves said actuator such that said body portion axially moves within said housing from a forward position to a rearward position, and wherein application of a pushing force on said grip portion moves said actuator such that said body portion axially moves within said housing from said rearward position to said forward position; and

10 a connecting means between said actuator body portion and said drive member for not axially moving said drive member when said actuator body portion axially moves within said housing from said forward position to said rearward position, and for axially moving said drive member forward when said actuator body portion axially moves within said housing from said rearward position to said forward position to thereby advance said  
15 plunger to force medicine from said reservoir through said outlet.

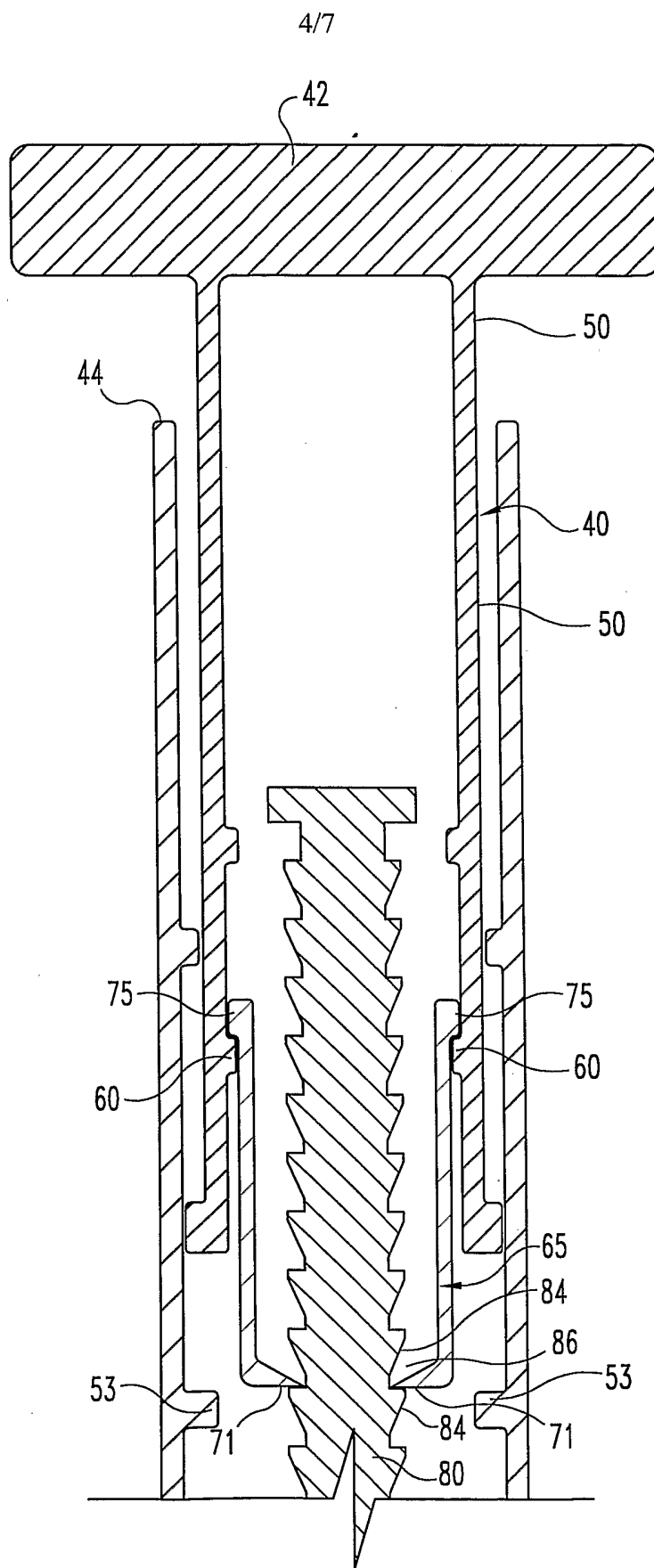


**Fig. 1**

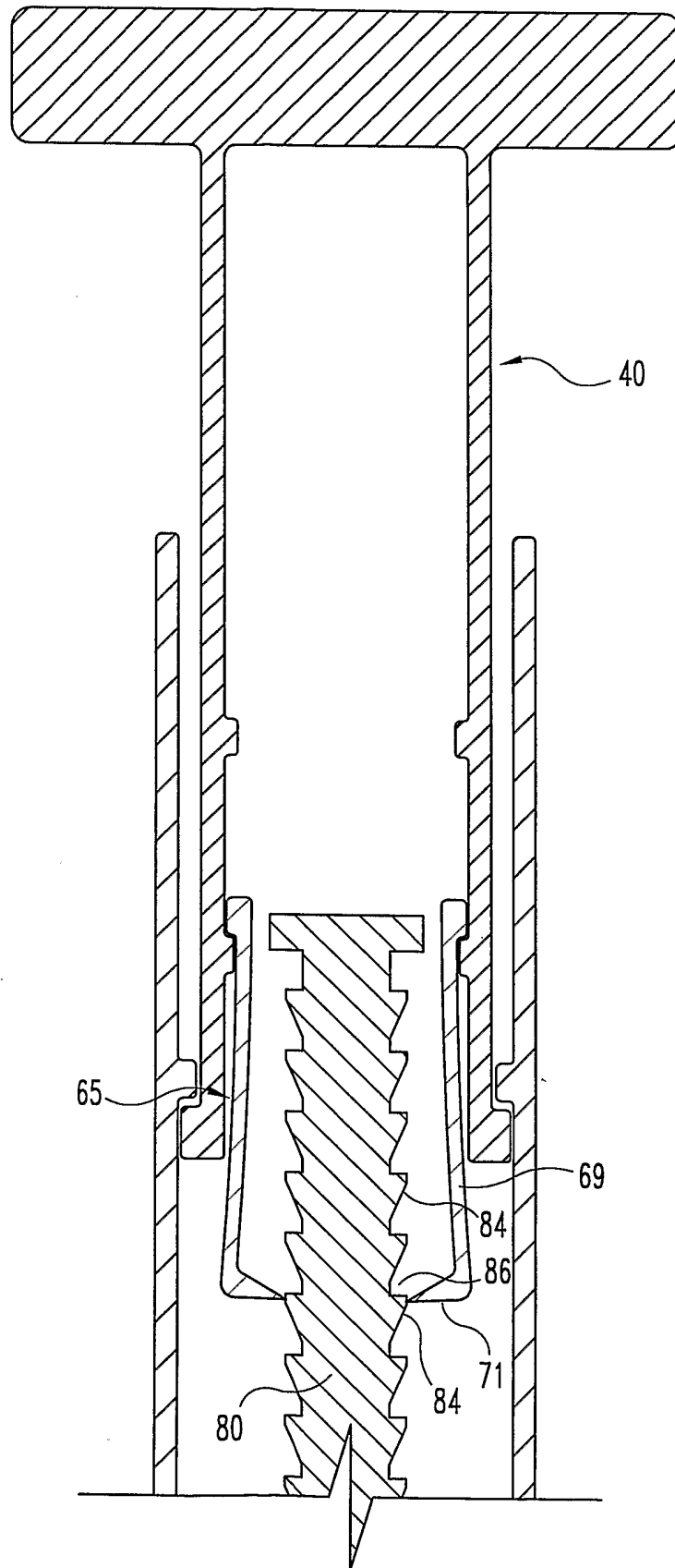




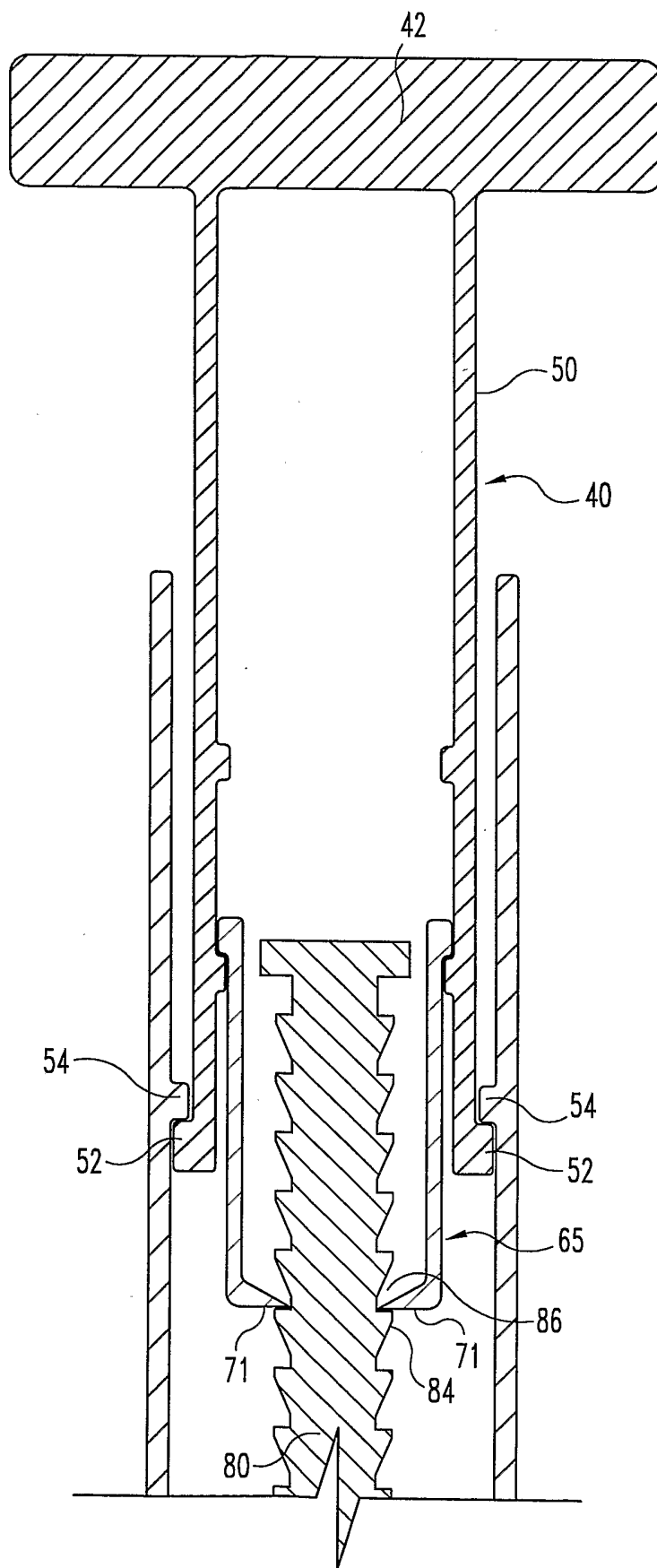
**Fig. 3**



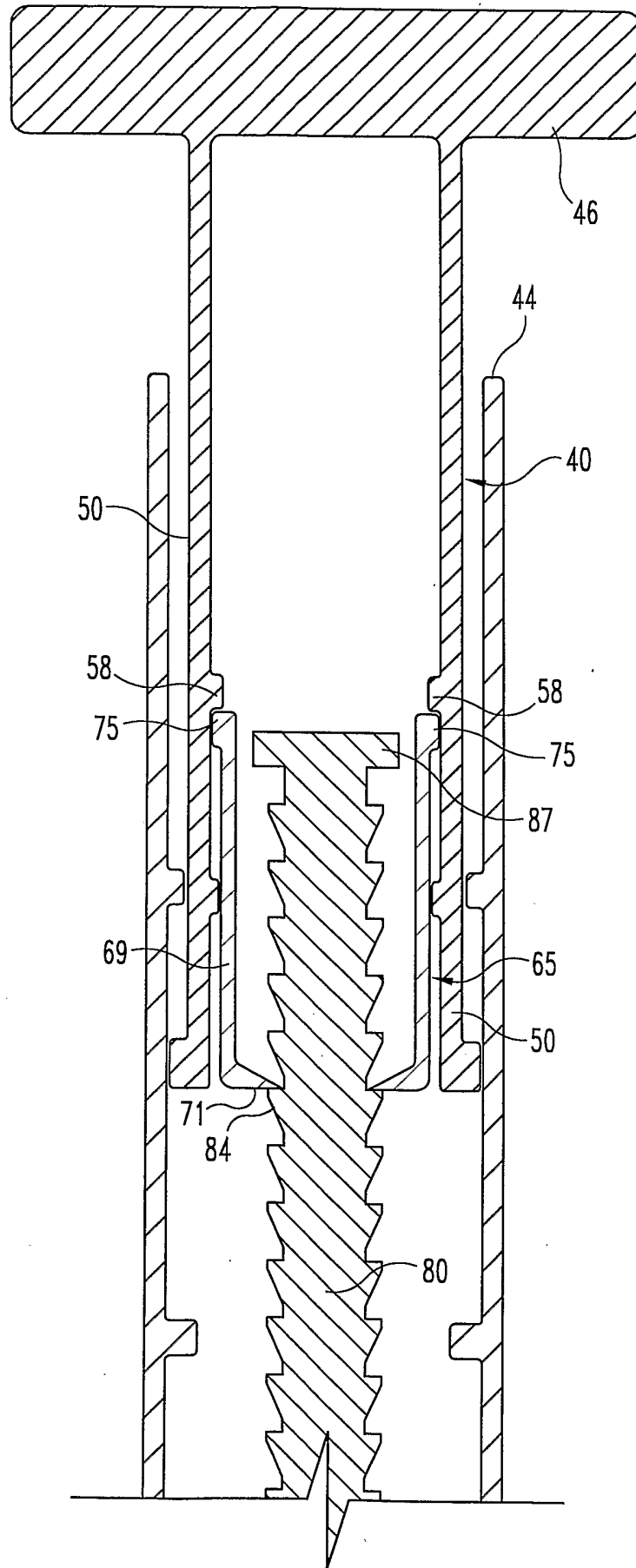
**Fig. 4**



**Fig. 5**



**Fig. 6**



**Fig. 7**