

D. Cumming Jr,

Wringer,

N^o 53,580.

Patented Apr. 3, 1866.

Fig. 1

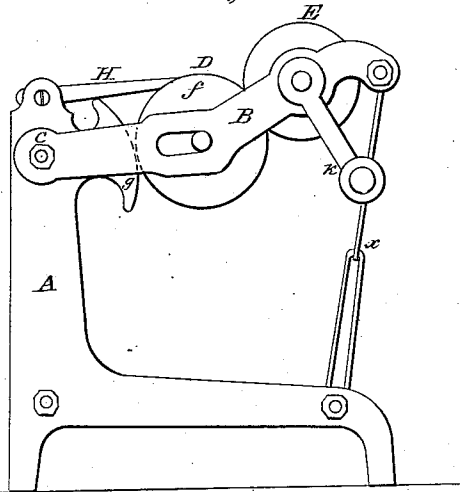

Fig. 2

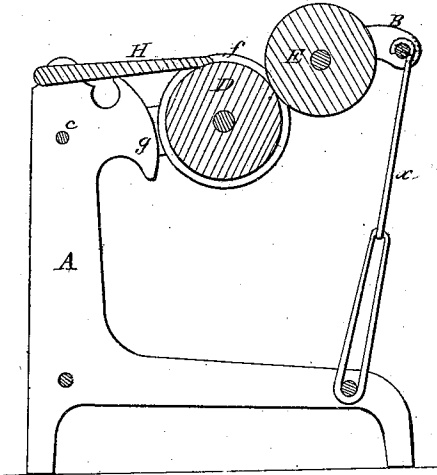

Fig. 3

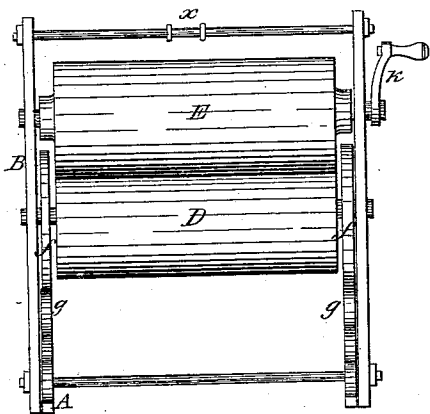

Fig. 4

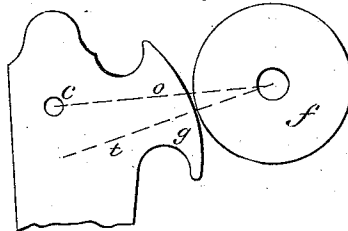
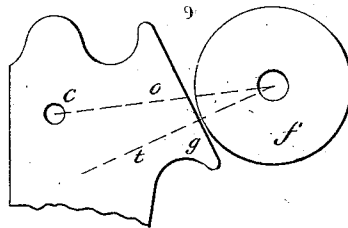

Fig. 5



Witnesses:

*Steph. M. Smith
J. Henry Wilkins*

Inventor:

David Cumming Jr

UNITED STATES PATENT OFFICE.

DAVID CUMMING, JR., OF NEW YORK, N. Y.

IMPROVED MANGLE AND WRINGER.

Specification forming part of Letters Patent No. 53,580, dated April 3, 1866.

To all whom it may concern:

Be it known that I, DAVID CUMMING, Jr., of New York, county and State of New York, have invented a new and useful Improvement in Machines for Mangling and Wringing Clothes; and I do hereby declare that the following is a full, clear, and exact description of the construction and operation of the same, reference being had to the annexed drawings, making a part of this specification, in which—

Figure 1 is a side elevation; Fig. 2, a transverse section; Fig. 3, a top view with the shelf H removed, and Figs. 4 and 5 details of a portion of the machine.

The same letters refer to corresponding parts in the different figures, in which—

A is the main frame; B, a vibrating frame hung on pins attached to the main frame at *c c*.

D E are rollers, having bearings in the vibrating frame. The bearings of the roller D are slotted so that it may be moved to or from the roller E. The journals of the roller D have bearings also in the circular plates *f f*. *g g* are abutments firmly attached to the main frame.

The weight of the rollers, the vibrating frame, and all attached thereto, are supported by the circular plates bearing against the abutments, which has a tendency to press the roller D against the roller E, thereby giving the necessary pressure for mangling or wringing the clothes.

The edges of the abutments may be of any shape, provided the point of contact between

them and the circular plates shall be below a line drawn from the center of the roller D to the center of the pins, on which the vibrating frame is hung. Fig. 4 shows the abutments with curved edges, and Fig. 5 with straight edges. The dotted line O is drawn from the center of roller D to the center of the pins, on which the vibrating frame is hung. The dotted line *t* is drawn through the point of contact between the abutments and circular plates. The nearer the point of contact is to the line O the greater will be the pressure. The pressure can be increased by the use of the spring *x*, one end of which is attached to the main frame and the other end to the vibrating frame.

In operating, the clothes are placed on the shelf H and their ends placed between the rollers, which are rotated by the crank *k*. When the ends of the clothes are too thick to enter readily between the rollers, their entrance can be facilitated by raising the outer end of the vibrating frame, thereby causing the roller D to move away from the roller E.

What I claim as new, and desire to secure by Letters Patent, is—

The use of the abutments *g g*, in combination with two or more rollers, arranged substantially as described, and for the purposes set forth.

DAVID CUMMING, JR.

Witnesses:

STEPH. WM. SMITH,
J. HENRY WILKINS.