

(19)
(12)

(KR)
(A)

(51) 。 Int. Cl.7
G03B 21/20
G02B 27/28

(11)
(43)

10-2004-0103380
2004 12 08

(21) 10-2004-0037953
(22) 2004 05 27

(30) JP-P-2003-00154864 2003 05 30 (JP)

(71) 가 가 2 4-1

(72) 가 392-8502 3 3-5 가 가

(74)
:

(54) ,

가

()

()

3

1 1

2 1

3 1

4	1	,	1
5	1	2	.
6	1	3	.
7	1	,	.
8	1	.	.
9	1	.	.
10	2	.	.
11	2	.	.
12	2	,	.
13	3	.	.
14	3	.	.

*

10R,10G,10B:

20R,20G,20B: ()

40:

61: ()

61b,71b,81b: ()

61c:

62,72,82: ()

71c: ()

81c: ()

102,103,104:

P0, Pm, P':

가 , 가 가
()가

(Digital Mirror Device, DMD)

가

(1) (迷光) , (Cathode Ray Tube, (階調範圍)(dynamic range)가 (迫力)(impression)

(2)

가

() (調光手段)(light control means) 가 (, , 1). (

(1) 5-66501

(,) 가 (highlight)

가 (shadow) 가

가

() 가 , ,

100%

가

1 (margin) 1

(1)

, 1 8 , 1

, R(), G(), B() 3

1 3 , 20R, 20G, 20B (Cross Dichroic Prism) , 40 () , 30 () , 41

(10R,10G,10B) (LED), (EL), 가 10(10R,10G,10B) (11) (EL) (11) (20R,20G,20B) (10R,10G,10B) (12) 가 가

(30) 4 () , (30a,30b) (20G,20B) (20R) (30a) (20R, 20G) (30b) (20G,20B) (20B) (20R, 20B) (40) (41)

2 (60) (101) (102)()가 (102) , 가 (Rm) 가 가 (normal)"/ " (dynamic)"/ " "/ " " 50%/ 75%/ 25%/ 0% (Rm) (, 0 Rm) (Rm) (60)

(60) (10R 10B) (T) (10R 10B) (61) (T) (10R 10B) (61) (64), (P0) (61) (T) (10R 10B) (61) (62), (30G)(5 G), (30B)(5 B) (30R)(5 R) (63)

c) (61) 3 (61a), (61b), (61) (61d) (61) (101) 가 (61a) (61b) (61) (61) (101) 가 (61a) (61b) (10R 10B) (61b) (61b)

3가

(a) 가
 , 0 255 256
 , 가 ()가 4 1
 , 가 190 , 가 190

(b) (, 10%)
 10% , 가 5 , 10%
 가 230 , 230 5
 , 255 , (a) , 255가
 가 230 ,
 , 2 50%

(c) ,
 () , 6 , m×n , (A₁₁ , ..., A_{mn})
 6 200

(a) (c) , 가 ,
 , 가
 () 100% , 190 1.0 190/255=75%가 (T0) , 가 255)
 , () (61c) ()

(T0) (61d) , (T
) , (Rm)) , 가 (61d) 가 (T0) (T0) (T) , 가 (T
 (T0) 가 (0 Rm () (Rm) (Rm) (T) ,
 , (T) (Rm) (64) , (64)
 (10R 10B)

(61d) (T) (P0) , 가
 , 가 (T0) (T) (P0) (1/T) (P0) (T) (1/T)
 , (P0) (62)

7 8 (Rm) 25%(, 0% 25%) , , 7 8
 가 (Rm) Tm, Pm

1 가 가 217 , 217 7(a) , 가 (T0)
) 217/255=85%가 (T0)

(T) (T0) (P0) (T0) 1/T0=1.18
 (7(b)). (62) 0 217 0 255

128 8(a) 가 가 128
 , 가 (T0) 128/255=50%가

(T0) (Rm) (P0) (Rm) (T) 1/(1-Rm)=Pm=1
 .33 (8(b)). (62) 0 128 0 1
 71

가 (255) 가 가
 , P0 (P') 9(a) (T) 9(a) Pm
 213 , 가 (62) (9(b)). 0 128 Rm (P') 1.66 0

가 가

(2)

10 11 2
 , 1

10 (70)

() (103)가 (103) (101)

(70)

(70) (10R 10B) (T)
 (P0) () (71), (71)
 (10R 10B) (74), (P0)
), () (72) (30G)(5 G) (30B)(5 B) (30R)(5 R)
 (73)

(71) , 11 (71a), (71b), (71c)
 (71d)

1 (71a) (101) 가 (71a) ()
) 가 ()가

(71b) (10R 10B) . ,
 (71b) (71b) (T0) 1
 (71c) () LUT(look-up table)
 LUT () (Rm) 가 (Rm) LUT ,
 12 가 (71c)
 (T0) (71d) (T) (P0) 1 (T)
 (P0)
 (3)
 13 14 3
 1
 13 (80)
 (104)가 (101)
 (104) (80) (104)
 (80) (10R 10B) (T)
 (P0) (81), (81)
 (10R 10B) (81) (P0)
 () (82), (30R)(5 R
 (30G)(5 G) (30B)(5 B)
 (83)
 (81) 14 (81a), (81b), (81c)
 (81d)
 1 (81a) (101) 가 (81a) ()
 (8b) (8b) (10R 10B) 가
 (81b) (81b) (T0) 1
 (81c) ()
) LUT (Rm) LUT LUT (Rm)
 (Rm) 가 가 (81c)
 (T0) (81d) (T) (P0) 1 (T)
 (P0)

가

가

가

LED

3

1

DMD

가

(57)

1.

;

(調光手段)(light control means)

2.

1

;

2 3. ,

,

1 4. 3 ,
가

1 5. 3 ,

1 6. 3 ,

1 7. 6 ;

;

7 8. ,

(image-signal expanding means)

8 9. ,

가

8 10. 9

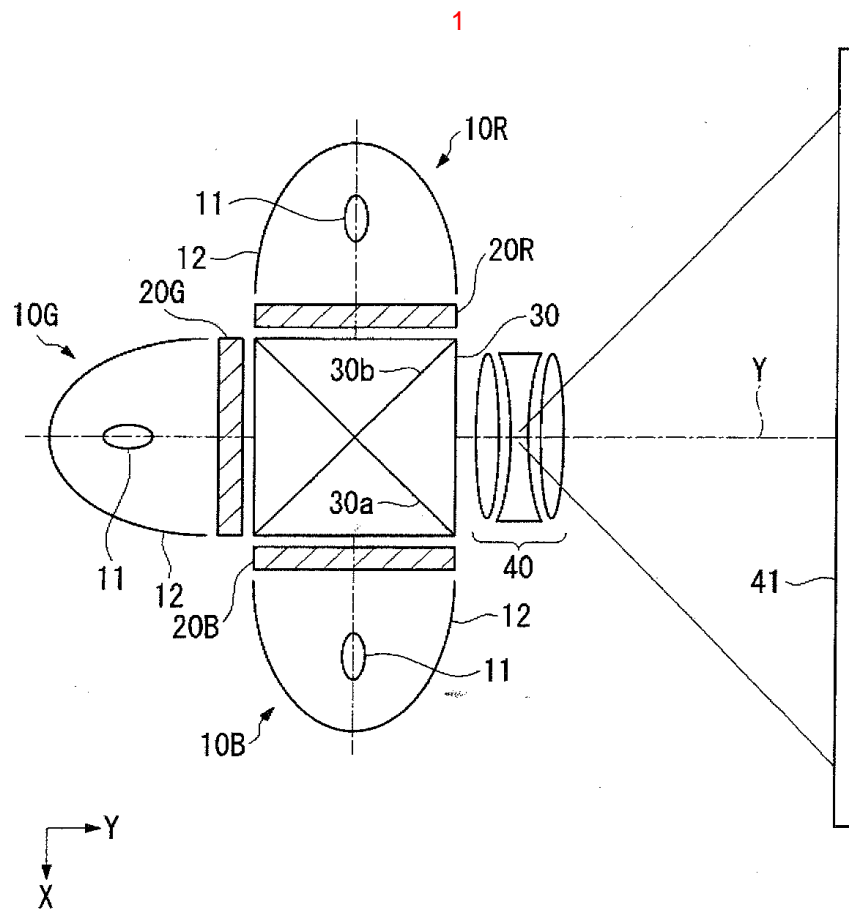

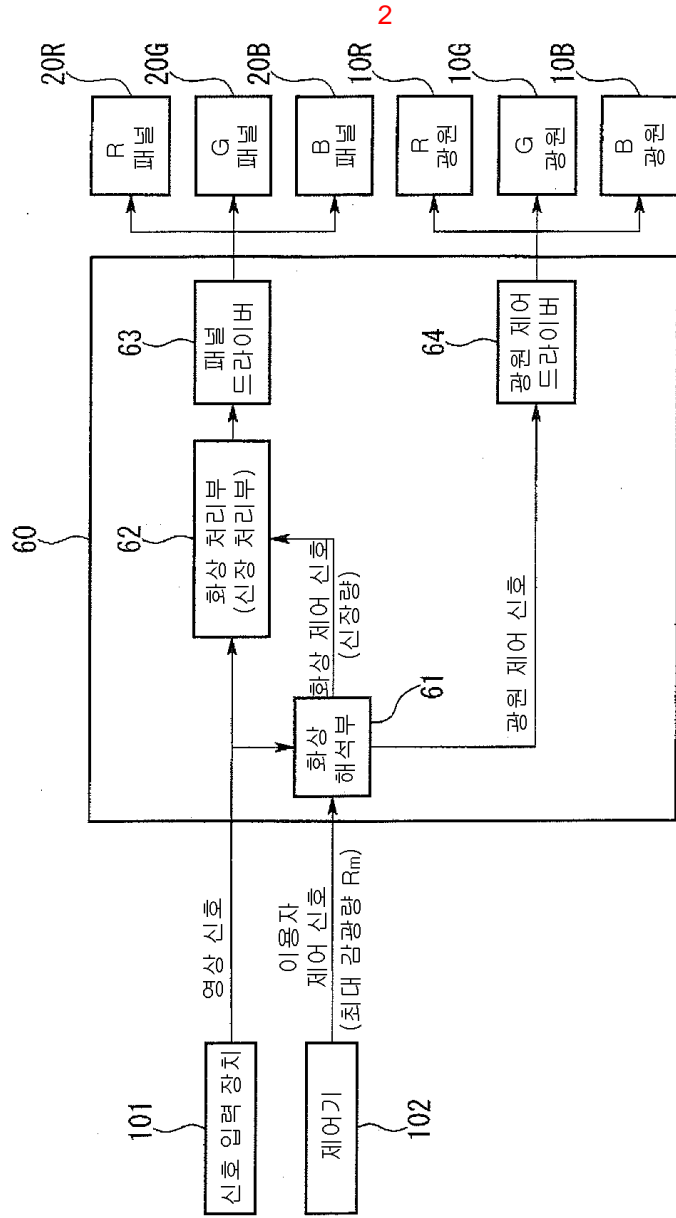

3

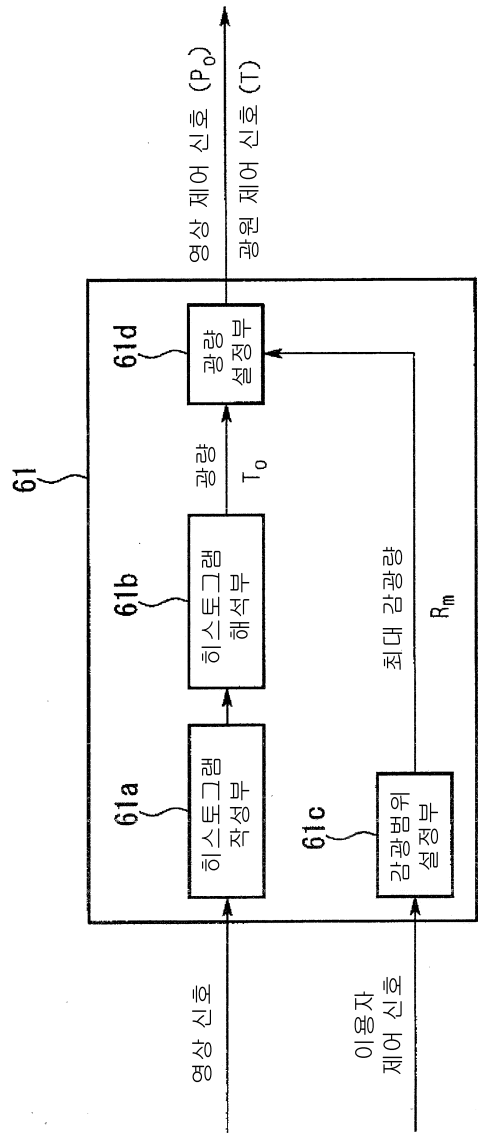

4

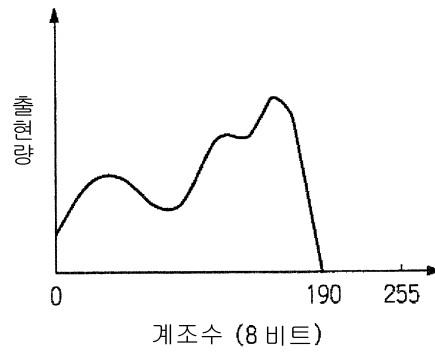

5

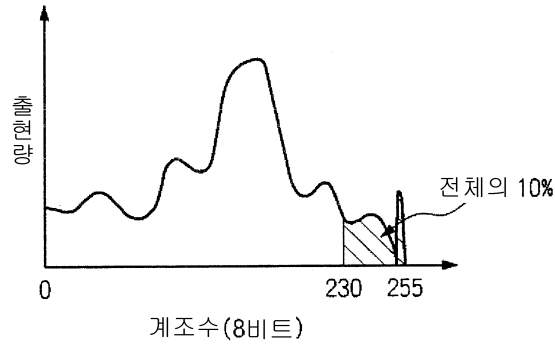

6

A_{11}	A_{12}	A_{13}	A_{1n}
A_{21}			
A_{31}			
\vdots			
\vdots			
A_{m1}			A_{mn}

7

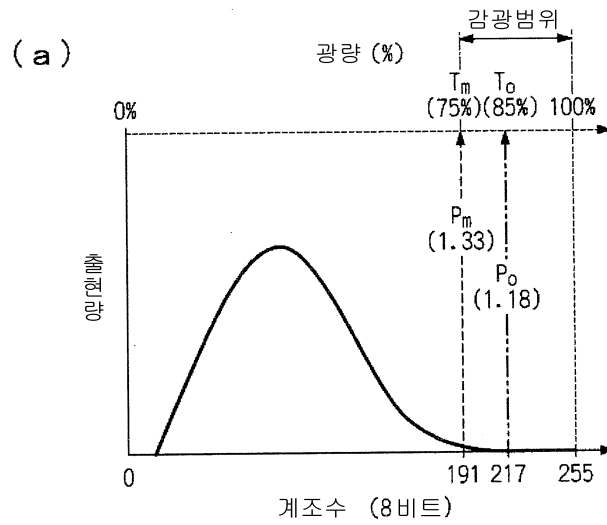

(b)

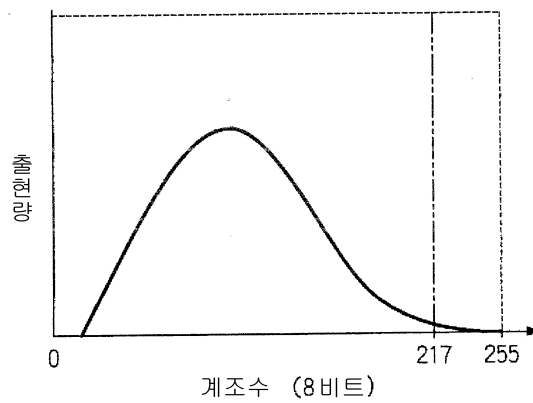

8

(a)

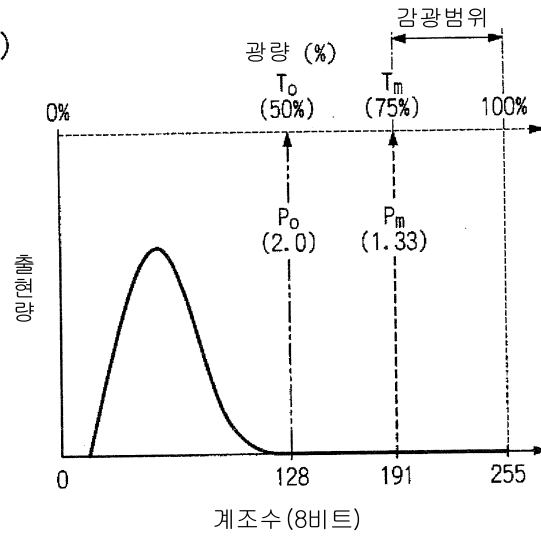

(b)

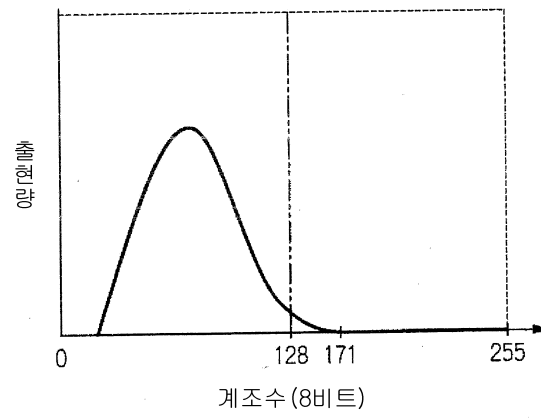

9

