

June 22, 1937.

W. R. NEESE

2,084,449

POWER SHOVEL

Filed July 23, 1936

2 Sheets-Sheet 1

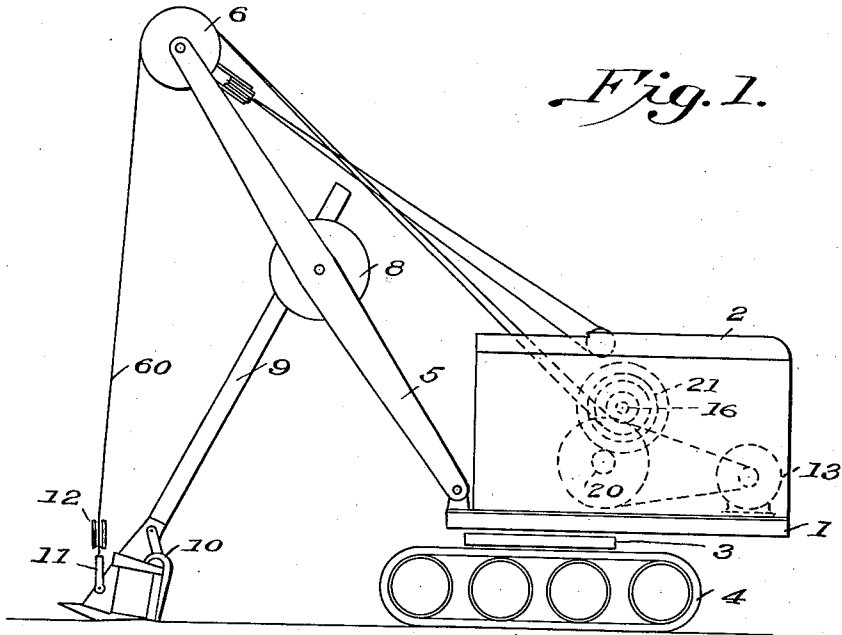

*Fig. 1.*

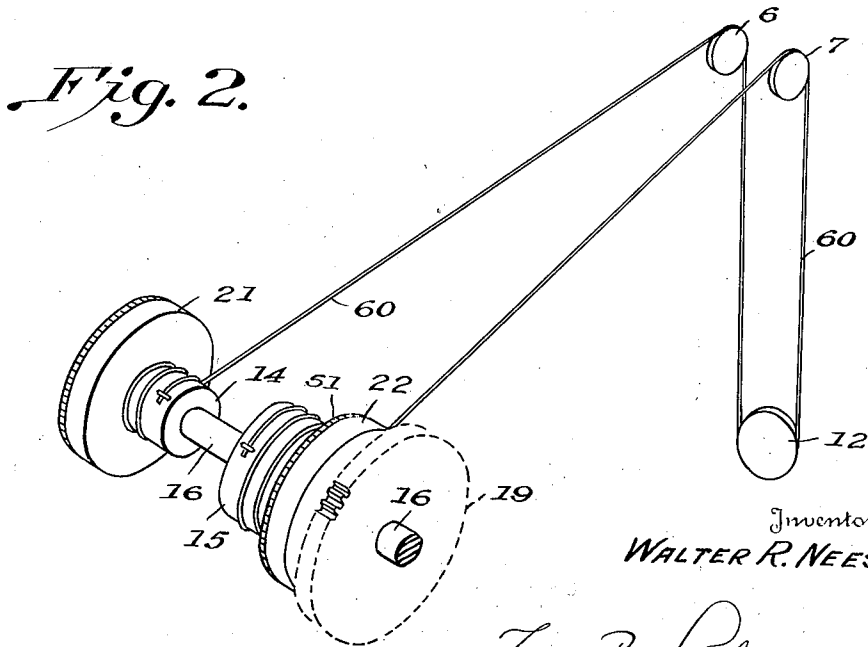

*Fig. 2.*

Inventor  
WALTER R. NEESE

By *Francis B. Leach*

Attorney

June 22, 1937.

W. R. NEESE

2,084,449

POWER SHOVEL

Filed July 23, 1936

2 Sheets-Sheet 2

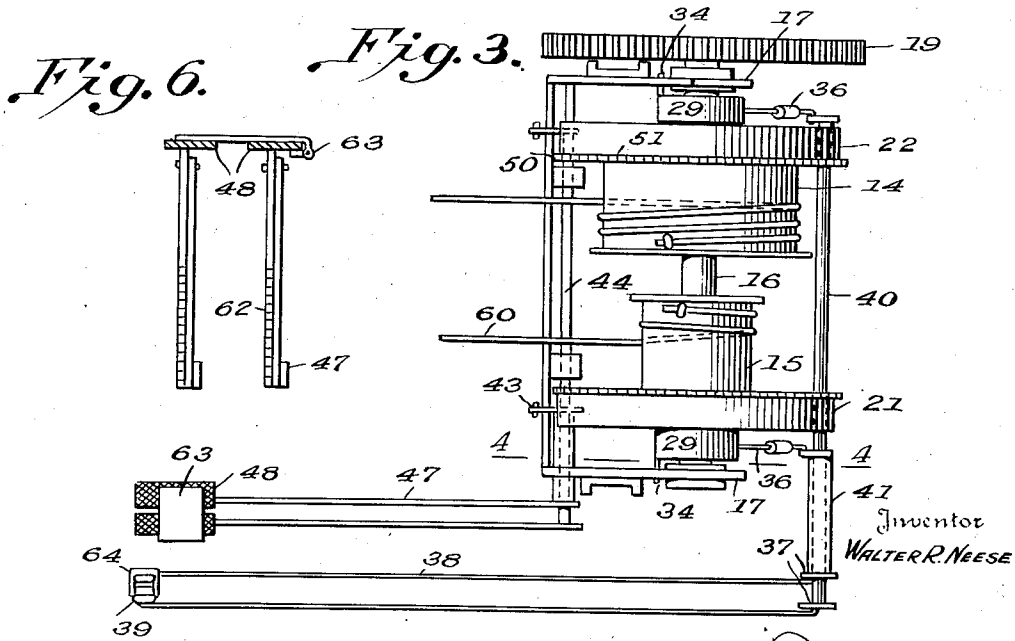
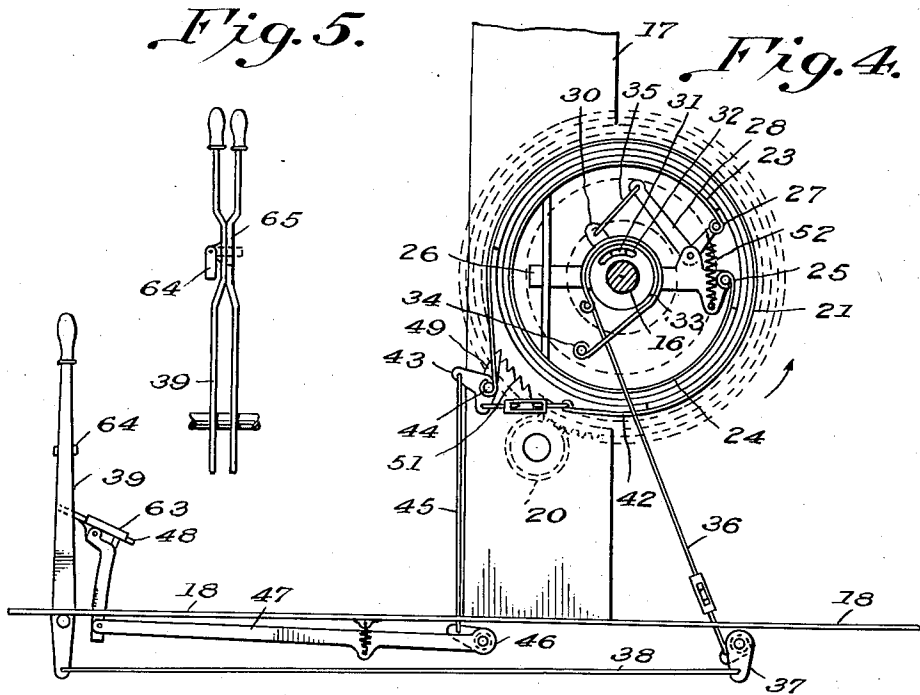

James B. Beck

Attorney

# UNITED STATES PATENT OFFICE

2,084,449

## POWER SHOVEL

Walter R. Neese, Max Meadows, Va.

Application July 23, 1936, Serial No. 92,255

3 Claims. (Cl. 214—135)

This invention relates to power shovels of the type wherein a dipper for moving material is attached to the end of a dipper arm carried on a pivoted traversing arm.

whose outer end is affixed a dipper bucket 10. The thrust or traversing mechanism of the boom will not be described in detail as it forms no part of this invention as any conventional means may be used for these purposes.

The principal object of the invention is to provide a means for hoisting the dipper to insure that it will have sufficient power to remove material in cutting away a bank regardless of the formation thereof. Considerable difficulty has been experienced with conventional power shovels when operating to strip a bank for the reason that many times portions thereof are of such close texture or of such hardness that sufficient power cannot be applied through the usual hoist line to raise the dipper and cut away the bank.

A pivoted bail 11 is affixed to the dipper bucket 10 and secured thereto is lifting pulley 12 through which the hoisting cable passes.

Another object of the invention is to provide such a power shovel wherein the dipper is hoisted or lifted by a double hoist line and in which the free ends of the hoist line are wound up on separate winding drums having different diameters.

Mounted interiorly of cabin 2 is a suitable prime mover 13 which may be electric, steam, gasoline or Diesel operated. Also within the cabin are two hoisting drums 14 and 15 loosely mounted on horizontal shaft 16 journalled between vertical side plates 17 securely affixed to the flooring 18. Power drive gear 19 is keyed to one end of shaft 16 and secures rotation through pinion 20 driven by any suitable drive means from prime mover 13. As shown in Figs. 2 and 3, winding drums 14 and 15 are each affixed to similar brake and power transmission drums 21 and 22 respectively. It will be necessary to describe only one of said brake and power drums as they are identical.

A still further object of the invention is to provide a selective power transmission for the winding drums to enable them to be operated either individually or jointly.

Referring to Fig. 4 brake drum 21 of winding drum 15 has mounted interiorly thereof an internally expanding brake band 23 that functions as a power transmitting clutch and is carried on flexible brake shoe 24, the end 25 of the shoe being affixed to cross bar 26 loosely carried on shaft 16 while the opposite or free end 27 of the brake shoe is carried on the arm of bell-crank 28. Power to expand the brake shoes and contact the winding drums is secured through the medium of booster clutch brakes comprising small diameter drums 29 keyed on the ends of shaft 16. Each booster includes an operating arm 30 having an off-set lug 31 passing through arcuate slot 32 formed in the side wall of the booster brake drum and connected through link 35 to the free end of the bell-cranks 28. Flexible contracting brake bands 33 pass around the booster brake drums and are anchored at one end to lugs 34 fastened to the side plates 17, while the free ends are secured to operating rods 36 whose outer ends terminate in arms 37. The off-set portions of the arms are attached to rods 38 pivoted to the lower ends of hand levers 39. A horizontal rotary rod 40 transmits power from the operating handle 39 connected up to drum 14 while power is transmitted to the brake drum affixed to drum 15 through rotary sleeve 41 surrounding one end of rod 40.

The invention also contemplates arranging for the interlocking of the controls in such a manner that the operator may, at will, apply to the dipper, power from one or the other of the winding drums or he may apply power to them together and also provide means for braking either or both of the drums through an interlocking foot brake which may be manipulated to temporarily brake the drums or to permanently hold them in position.

In the drawings:

Fig. 1 is a side view of a power shovel rigged in accordance with this invention.

Fig. 2 is a diagrammatic view illustrating the hoist line and winding drums.

Fig. 3 is top plan view of the hoisting drum mechanism.

Fig. 4 is a side view partly in cross section taken on line 4—4 of Fig. 3.

Figs. 5 and 6 are fragmental views showing the interlocking of the hand and foot control levers.

Specifically in the drawings numeral 1 denotes a power shovel having the usual power plant and control cabin 2, mounted on turn table 3, carried by endless track chains 4. A boom 5 is pivoted to the front portion of the cabin framing and extends outwardly and upwardly terminating in two lifting pulley sheaves 6 and 7. The position of the boom 5 is regulated by conventional elevating rigging. Also carried by the boom intermediate its ends is a roller or pulley mechanism 8 for applying thrust or crowd to dipper arm 9 on

Each of the brake drums 21 and 22 is provided with a positive braking and holding means comprising contracting brake bands 42 encircling the drums and terminating in bell-cranks 43 pivoted to horizontal rod 44. The off-set portion of

the bell-cranks 43 are moved through reciprocation of rods 45, receiving movement from cams 46 which are rotated by means of levers 47 affixed to foot levers 48. Positive latching dogs 49 are freely mounted on shaft 44 and may be manually pivoted to engage with teeth 50 carried on rack wheels 51 affixed to each of the brake drums 21 and 22.

In operation a continuous hoisting line or cable 60 is secured at its ends to hoisting drums 14 and 15 and passes up and around sheaves 6 and 7 mounted on the end of boom 5 while pulley 12 secured to the arbor 11 of the dipper bucket 10 is hung in the loop of the line 60.

To raise the dipper bucket the operator pushes either of the operating handles 39 whereupon pressure is applied to the booster brake 29 and as the booster brake drum is affixed to shaft 16 it tends to retard the rotation thereof and permit off-set lug 31 to move or slide to the end of the arcuate slot 32 and thus give movement to arm 30 which is transmitted through the crank 28 and expand the internal brake band 21 and rotate therewith. Power is transmitted from the shaft 16 to the hoisting drum as long as the operating lever is in forward position. When the operating lever is brought back to vertical or neutral position the springs 52 draw the free end of the brake drums away from their inner peripheries to disconnect the transmission of power. Inasmuch as both of the hoisting drums 14 and 15 are loosely mounted on the power shaft, power may be applied to either of the drums or they may be operated simultaneously.

In working the shovel and particularly while stripping down banks of material it has been found that the geological formation of the bank changes in character and thus the same upward stroke of the dipper may encounter soft, medium and hard sections. When a power shovel is provided with mechanism for hoisting the dipper as described in this application the operator has at his command adequate facilities for coping with any material formation which may be encountered. As the dipper strikes a particularly hard formation the hoist line 60 may be slowly drawn in by applying torque to the small diameter winding drum 15 which will raise the dipper bucket with tremendous lifting power. If a comparatively soft formation is being operated on the shovel operator need only apply power to the larger diameter hoist drum 14 or on the other hand when the formation is quite soft or light in weight power may be applied simultaneously to both of the winding drums which will cause the bucket to ascend quite rapidly. In effect, therefore, the operator has at his instant command a differential hoist mechanism similar in many characteristics to the low, second and high speed gearing of an automobile.

The foot pedals 48 connected through operating levers 47 and reciprocating rods 45 rotate bell-crank 43 to tighten outer brake bands 42 when it is desired to slow up or arrest the rotation of the winding drums. The foot pedals 48 are also provided with rack teeth 62 to engage a suitable latch fastened to the floor plat 18 so that the operator may temporarily lock the brakes to hold the drums and dipper in any desired position. The foot pedals 48 are of the conventional pivoted type so that the teeth 62 may be readily disengaged from the latch. If it is desirable to permanently lock the brakes the operator manually engages the dogs 49 with

ratchet teeth 50 formed on wheel 51. The dogs 49 are loosely hung on rod 44 and may be pivoted therearound to engage a tooth on the ratchet wheel 51 when the operator desires that the drums be positively locked. It is a very small matter to disengage these latches when manual operation is desired.

Provision is also made for operating the foot pedals 48 or the hand levers 39 simultaneously. This is accomplished by having a pivoted plate 63 attached to one of the foot pedals so that in operative position it overlies both pedals and consequently pressure applied on the plate 63 will depress both pedals. When it is desired to operate the pedals individually it is only necessary for the operator to kick the plate 63 over upon its pivot to lie out of engagement therewith. A somewhat similar device is utilized for interconnecting the hand levers 39 and in the form shown in Fig. 5 consists of a pivoted fork 64 which may be readily swung to horizontal position to tie the two handles together where they are off-set at 65. It will be understood that the keeper 64 is readily moved to the inoperative position shown in Fig. 5 to disengage the handles, one from the other.

What I claim is:

1. A power shovel plant of the character described including an elevating arm carrying a dipper, an elevating sheave secured to the said dipper, a prime mover carried on the said shovel, a plurality of winding drums also carried on said shovel, said drums being loosely mounted on a single horizontal shaft secured between vertically extending spaced brackets secured to the side frames of the shovel plant, means for transmitting power to said drums from said prime mover, the said drums being of substantially different diameters, a hoisting cable attached at either end to said drums, said cable passing through said elevating sheave and power take-off devices including booster brakes enabling each of said winding drums to operate independently of each other, the said booster brakes each comprising an offset brake drum attached to each of the winding drums and each having a transverse arm loosely affixed to the said winding drum shaft, an offset lug on each of said levers and an arcuate slot in each of said brake drums adapted to be engaged by the said lugs, tension means for each of said drums for moving the end of said arcuate slot against said lug and expanding brake shoes carried interiorly of each of said winding drums connected to and expanded by said transverse levers.

2. In a power shovel, a platform, a boom pivoted to one end of mid-platform, a dipper arm supported by and moveable with said boom, a dipper secured to the outer end of said arm, a sheave connected thereto, two parallel sheaves mounted on the upper end of mid-boom, a horizontal power driven shaft mounted in brackets secured to said platform, two winding drums loosely mounted on said shaft, one of said drums being of substantially larger diameter than the other of said drums, a single cable threaded through said dipper sheaves and having one of its ends secured to each of said drums, foot operated brakes for arresting rotation of each of said drums, hand levers operating booster brakes for applying power from said shaft to either of said drums individually or jointly, ratchet wheels secured to each of said winding drums and manually operated locking dogs for engagement with said ratchet wheels.

3. A power shovel of the type described, including a material lifting dipper, a pulley attached

winding drums, brake shoes mounted interiorly thereto, a plurality of hoisting drums, a continuous lifting cable running from one of said drums, around said pulley and back to the other of said drums, a source of power connected to said drums and control means for rotating either or both of said hoisting drums, said means comprising individual brakes secured to each of said

of each of said drums, means for expanding each of said shoes by the rotation of the individual drums and a manually operated tension band for applying torque to said winding drum shaft to which each of said brake shoes are pivoted to engage said brake shoes with said drums.

WALTER R. NEESE.