

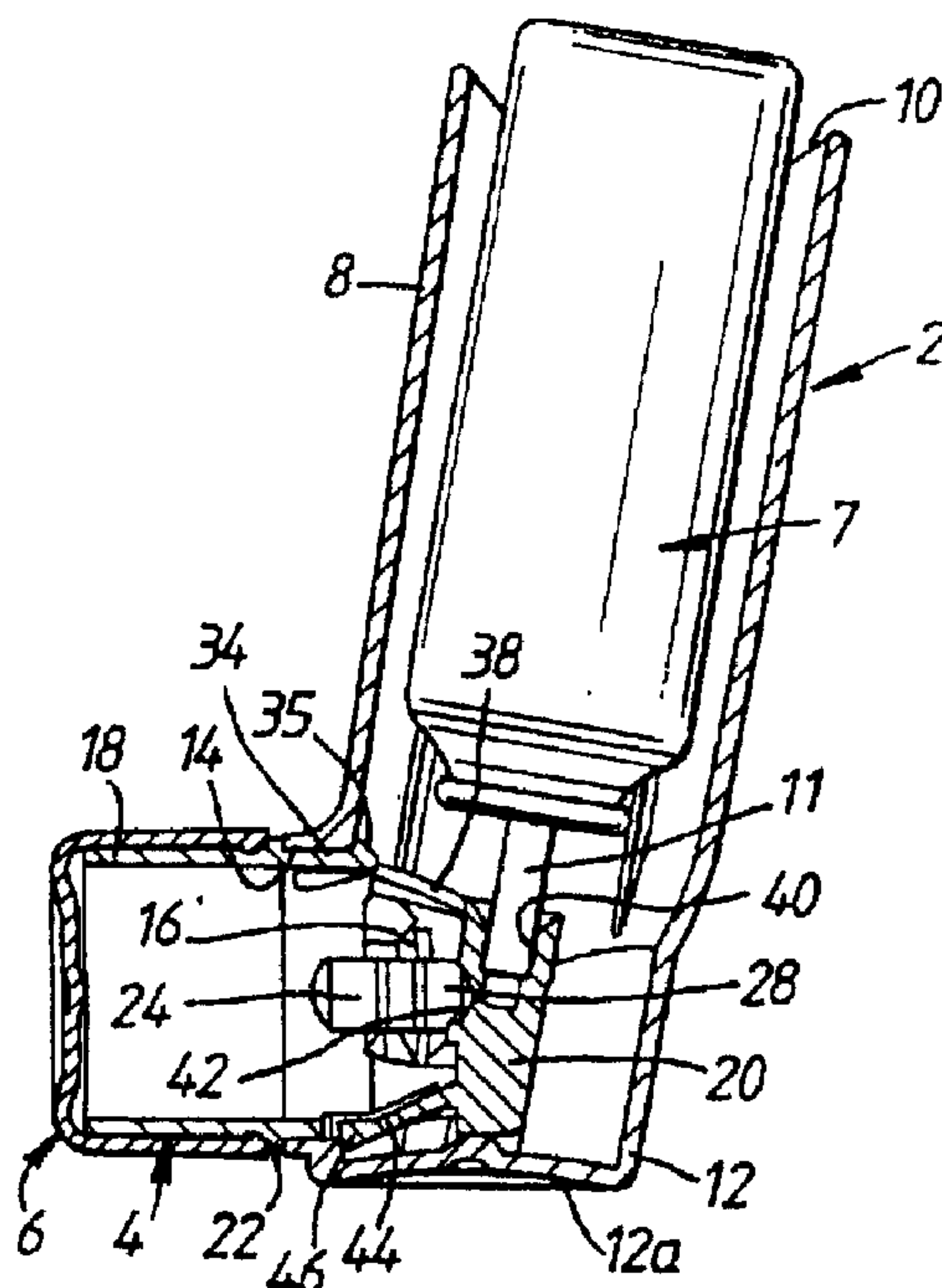

(22) Date de dépôt/Filing Date: 1998/11/11
 (41) Mise à la disp. pub./Open to Public Insp.: 1999/05/27
 (45) Date de délivrance/Issue Date: 2011/07/19
 (62) Demande originale/Original Application: 2 310 224
 (30) Priorité/Priority: 1997/11/14 (SE9704185-9)

(51) Cl.Int./Int.Cl. *A61M 15/00* (2006.01)
 (72) Inventeurs/Inventors:
 HODSON, DARREN, GB;
 RASMUSSEN, JORGEN, DK
 (73) Propriétaire/Owner:
 ASTRAZENECA UK LIMITED, GB
 (74) Agent: FETHERSTONHAUGH & CO.

(54) Titre : DISPOSITIF D'INHALATION AVEC UN ASSEMBLAGE DE SORTIE ENCLIQUETABLE FOURNI SEPARÉMENT ET POUVANT ÊTRE INSÉRÉ DANS UNE OUVERTURE LATÉRALE DU DISPOSITIF
 (54) Title: INHALATION DEVICE WITH A SEPARATELY PROVIDED, SNAP-FIT OUTLET ASSEMBLY FOR RECEIPT IN A LATERAL OPENING OF THE DEVICE



(57) Abrégé/Abstract:

Disclosed herein is an actuator for an inhaler for delivering medicament by inhalation. The actuator includes a main body having a tubular member for receiving a canister containing a medicament and having a valve stem extending therefrom and an outlet assembly, as a part formed separately of the main body. The outlet assembly includes a mouthpiece for guiding the medicament to the mouth of a user and a nozzle block for receiving the valve stem of the canister and delivering medicament from the canister into the mouthpiece. The actuator may have one of any number of different physical styles or appearances. The outlet assembly is a common part for any of the different styles of actuators. The outlet assembly is formed such that it comprises all parts of the actuator that come into contact with the medicament. The main body and outer assembly have complementary shape catch members that allow them to snap-fit together.

23940-1311G

5

ABSTRACT

Disclosed herein is an actuator for an inhaler for delivering medicament by inhalation. The actuator includes a main body having a tubular member for receiving a canister containing a medicament and having a valve stem extending therefrom and an outlet assembly, as a part formed separately of the main body. The outlet assembly includes a mouthpiece for guiding the medicament to the mouth of a user and a nozzle block for receiving the valve stem of the canister and delivering medicament from the canister into the mouthpiece. The actuator may have one of any number of different physical styles or appearances. The outlet assembly is a common part for any of the different styles of actuators. The outlet assembly is formed such that it comprises all parts of the actuator that come into contact with the medicament. The main body and outer assembly have complementary shape catch members that allow them to snap-fit together.

23940-1311G

1

INHALATION DEVICE WITH A SEPARATELY PROVIDED, SNAP-FIT OUTLET ASSEMBLY FOR RECEIPT IN A LATERAL OPENING OF THE DEVICE

This application is a divisional application of Canadian Patent Application No. 2,310,224, which was filed on November 11, 1998.

The present invention relates to an actuator for an inhaler for administering medicament by inhalation and to an inhaler including the same.

For some time, actuators have been known for delivering metered doses of medicament from aerosol canisters. These actuators comprise a single integral moulding and are usually coloured to identify the medicament being delivered. After use with only one canister the actuator is discarded. This is desirable, since some medicaments which are delivered, will, over time, become deposited in the nozzle block and the mouthpiece of the actuator.

It is an aim of the present invention to provide an actuator of two-part construction, with the parts being composed of materials having different constitution and configured so as not to be separable without being deformed or broken. Such two-part construction prevents re-use of the actuator, thereby ensuring that the actuator has to be thrown away after use with a single canister, and further allows for the manufacture of a range of actuators by providing the first part as a common part to the range and forming the second part from a material having different constitution and optionally any shape. Typically, the second part can be coloured or have a particular surface finish or decoration according to the medicament to be delivered. In addition, the second part can be formed to have a particular shape, such as that of an animal which may appeal to young children. Such two-part construction is also advantageous for preparing regulatory documentation which will include common data relating to the first part.

US-A-5520166 discloses a cassette for use in an aerosol delivery device. The cassette comprises, as separate parts, a mouthpiece and a housing to one end of which the mouthpiece is attached, but, in being intended to be located within another device, there is no requirement and no suggestion is made of forming the parts of the cassette of materials having different constitution.

23940-1311G

2

According to one aspect of the present invention, there is provided an actuator for an inhaler for delivering medicament by inhalation, comprising: a main body comprising a tubular member for receiving a canister containing medicament and having a valve stem extending therefrom; and an outlet assembly, as a part formed separately of the main body, comprising a mouthpiece for guiding medicament to the mouth of a user and a nozzle block for receiving the valve stem of the canister and delivering medicament from the canister into the mouthpiece; wherein the actuator belongs to a range of inhaler actuators, the outlet assembly is a common part for the range of actuators, the members of the range of actuators differ by the physical appearance of the main body, the outlet assembly is formed such that it comprises all parts of the actuator that come into contact with the medicament during normal use, the main body and the outlet assembly are provided with complementary snap catch members so as to snap-fit together, and the tubular member is provided with a lateral opening at one end of the tubular member for receiving the outlet assembly at an angle transverse to the length the tubular member.

According to another aspect of the present invention, there is provided an inhaler comprising the actuator according to the previous aspect and a canister containing medicament.

According to still another aspect of the present invention, there is provided a main body of an actuator for an inhaler for delivering medicament by inhalation, comprising a tubular member for receiving a canister containing medicament and having a valve stem extending therefrom; and for receiving an outlet assembly, as a part formed separately of the main body, comprising a mouthpiece for guiding medicament to the mouth of a user and a nozzle block for receiving the valve stem of the canister and delivering medicament from the canister into the mouthpiece, wherein the actuator belongs to a range of inhaler actuators, the outlet assembly is a common part for the range of actuators, the members of the range of actuators differ by the physical appearance of the main body, the main body is formed such that it does not come into contact with the medicament during normal use, the main body is provided with snap catch members that are complementary to snap catch members on the outlet assembly,

23940-1311G

3

and the main body is provided with a lateral opening at one end of the tubular member for receiving the outlet assembly at an angle transverse to the length the tubular member.

5 In some embodiments, the tubular member includes a lateral opening at one end thereof for receiving the outlet assembly at an angle transverse to the length thereof.

In some embodiments, the tubular member includes an opening at one end thereof through which a canister is in use fitted.

10 In some embodiments, the main body further comprises a foot at one end of the tubular member thereof which is configured such that, with a canister fitted therein, the actuator will stand unsupported with the tubular member extending generally vertically.

In one embodiment the bottom surface of the foot includes a recess for receiving a thumb or a finger of a user. Preferably, the recess is concave.

15 In another embodiment the bottom surface of the foot is flat.

In some embodiments, the actuator further comprises a breath actuation mechanism.

In some embodiments, the actuator further comprises a compliance monitor, in particular a dose counter.

20 In some embodiments the main body comprises one or both of the breath actuation mechanism and the compliance monitor.

In some embodiments the foot comprises one or both of the breath actuation mechanism and the compliance monitor.

25 In some embodiments the outlet assembly is formed as a single integral moulding.

23940-1311G

3a

In some embodiments, the nozzle block includes a bore having an opening for receiving the valve stem of a canister and a spray orifice configured to direct a spray into the mouthpiece.

5 In some embodiments, the outlet assembly is configured to deform or be broken in being separated from the main body.

In some embodiments a connection between the mouthpiece and the nozzle block is configured at least in part to break on separating the outlet assembly from the main body.

10 In some embodiments the connection between the mouthpiece and the nozzle block comprises at least one member connecting a lower part of the mouthpiece with a lower part of the nozzle block and at least one member connecting an upper part of the mouthpiece with an upper part of the nozzle block, with the at least one member connecting a lower part of the mouthpiece with a lower part of the nozzle block being configured to break on separating the outlet
15 assembly from the main body.

In some embodiments, the main body and the outlet assembly are configured so as to snap-fit together.

23940-1311G

4

In one embodiment the main body and the outlet assembly are composed of entirely different materials.

In another embodiment the main body and the outlet assembly are composed of the same basic material but include different additives such as colour pigment.

In some embodiments the main body and the outlet assembly are of different color.

The present invention also extends to an inhaler comprising the above-described actuator and a canister containing medicament.

The inhaler is a pressurized metered dose inhaler.

Embodiments of the present invention will now be described hereinbelow by way of example only with reference to the accompanying drawings, in which:

Figure 1 illustrates a perspective view of an inhaler in accordance with a preferred embodiment of the present invention;

Figure 2 illustrates a side view of the inhaler of Figure 1;

Figure 3 illustrates a front view of the inhaler of Figure 1;

Figure 4 illustrates a rear view of the inhaler of Figure 1;

Figure 5 illustrates a plan view of the inhaler of Figure 1;

Figure 6 illustrates an underneath plan view of the inhaler of Figure 1;

Figure 7 illustrates a horizontal sectional view (along section A-A) of the inhaler of Figure 1;

Figure 8 illustrates in enlarged scale a fragmentary view of the section illustrated in Figure
5 7;

Figure 9 illustrates a vertical sectional view (along section B-B) of the inhaler of Figure 1;

Figure 10 illustrates in enlarged scale a fragmentary view of the section illustrated in
10 Figure 9;

Figure 11 illustrates a perspective view of the outlet assembly of the actuator of the inhaler of Figure 1;

15 Figure 12 illustrates a plan view of the outlet assembly of Figure 11;

Figure 13 illustrates an underneath plan view of the outlet assembly of Figure 11;

Figure 14 illustrates a side view of the outlet assembly of Figure 11;

20

Figure 15 illustrates a rear view of the outlet assembly of Figure 11; and

Figure 16 illustrates a front view of the outlet assembly of Figure 11.

25 The inhaler comprises an actuator, which comprises a main body 2, an outlet assembly 4 fitted to a lower part of the main body 2 and a cap 6, and an aerosol canister 7 containing medicament fitted therein.

The main body 2 comprises a tubular member 8 having an opening 10 at one, the upper,
30 end thereof into which a canister 7 having a valve stem 11 extending therefrom is in use

fitted, and a foot 12 having a bottom surface which includes a recess 12a, in this embodiment concave in shape, for receiving typically a thumb of a user. In an alternative embodiment the foot 12 can be formed with a substantially flat bottom surface. The foot 12 serves to allow the actuator to stand unsupported on a flat surface such that, when the actuator is not in use, it can be stored in an upright position. This is particularly advantageous when an a canister 7 is fitted therein, since such canisters 7 should, ideally, be stored with the valve stem 11 directed downwards. The other, lower, end of the tubular member 8 is closed and includes a lateral opening 14, in this embodiment ovoid in shape, into which the outlet assembly 4 is fitted.

10

The main body 2 further comprises a pair of opposing projections 16 which extend inwardly from the inner surface of the tubular member 8 adjacent the lateral opening 14. The projections 16 are disposed to the sides of the lateral opening 14 and are spaced rearwardly therefrom.

15

The outlet assembly 4 comprises a tubular section 18, a major part of which defines the mouthpiece which is in use gripped by the lips of a user, and a nozzle block 20 connected thereto.

20

The tubular section 18 includes a radial outwardly-directed peripheral flange 22. When the outlet assembly 4 is inserted fully into the main body 2, the flange 22 abuts the lateral opening 14 such that the major part of the tubular section 18 extends outwardly of the main body 2.

25

The outlet assembly 4 further comprises first and second arms 24, 26 which extend rearwardly from respective sides of the tubular section 18. Each of the first and second arms 24, 26 includes a catch member 28, 30 which is adapted to engage with a respective one of the projections 16 on the inner surface of the tubular member 8 when the outlet assembly 4 is inserted fully into the main body 2. The catch members 28, 30 on the first and second arms 24, 26 each include a first surface 28a, 30a which has a rearwardly-

30

directed component and acts as a guiding surface, and a second surface 28b, 30b which is substantially orthogonally directed to the longitudinal axis of the outlet assembly 4 and acts as a locking surface.

5 The outlet assembly 4 further comprises a third arm 34 which extends rearwardly from the top of the tubular section 18. The third arm 34 includes a catch member 35 in the form of an outwardly-directed projection, which, when the outlet assembly 4 is inserted fully into the main body 2, engages behind a part of the tubular member 8 defining the lateral opening 14. The catch member 35 on the third arm 34, as with the catch members 28, 30
10 on the first and second arms 24, 26, includes a first surface 35a which has a rearwardly-directed component and acts as a guiding surface, and a second surface 35b which is substantially orthogonally directed to the longitudinal axis of the outlet assembly 4 and acts as a locking surface.

15 The nozzle block 20 is connected to the tubular section 18 by first and second pairs of connecting elements 36, 38. The first pair of connecting elements 36 extend between a lower part of the nozzle block 20 and a lower part of the tubular section 18. As will be described hereinbelow, in this embodiment the lower connecting elements 36 are configured to break or be permanently deformed on withdrawal of the outlet assembly 4
20 from the main body 2. The second pair of connecting elements 38 extend between an upper part of the nozzle block 20 and an upper part of the tubular section 18. The nozzle block 20 includes a tubular bore 40 which extends along the longitudinal axis of the tubular member 8 when the outlet assembly 4 is inserted fully into the main body 2. The tubular bore 40 is open at one, the upper, end and includes a laterally-directed spray orifice 42 at
25 the other, lower, end. The spray orifice 42 is configured to direct a spray into the tubular section 18. In this embodiment the tubular bore 40 is adapted to receive the valve stem 11 of a canister 7.

The outlet assembly 4 further comprises a fourth arm 44 which extends forwardly and
30 downwardly from the nozzle block 20. The distal end of the fourth arm 44 includes a catch

member 46 which, when the outlet assembly 4 is inserted fully into the main body 2, engages behind a part of the tubular member 8 defining the lateral opening 14. The catch member 46 on the fourth arm 44 includes a surface 46a which is substantially orthogonally directed to the longitudinal axis of the outlet assembly 4 and acts as a locking surface.

5

In manufacture, an outlet assembly 4 and a main body 2 are selected according to the requirements, based on colour, shape, etc., for the actuator. The outlet assembly 4 is then inserted into the lateral opening 14 in the main body 2 until the catch members 28, 30 on the first and second arms 24, 26 of the outlet assembly 4 engage with the respective
10 projections 16 on the inner side surface of the tubular member 8 of the main body 2, and the catch members 34, 46 on the third and fourth arms 34, 44 of the outlet assembly 4 engage behind respective parts of the tubular member 8 defining the lateral opening 14. A canister 7 is then passed into the tubular member 8 of the main body 2 through the upper opening 10 such that the valve stem 11 of the canister 7 is located in the tubular bore 40 in
15 the nozzle block 20. The inhaler is then ready for use.

By the provision of catch members the outlet assembly 4 is held in the main body 2 and the outlet assembly 4 cannot be non-destructably detached from the main body 2. As mentioned hereinabove, the outlet assembly 4 is configured to break or be permanently
20 deformed if withdrawn from the main body 2 and thereby render the outlet assembly 4 and hence the actuator unusable. In this embodiment this is achieved by configuring the lower connecting elements 36 connecting the tubular section 18 and the nozzle block 20 of the outlet assembly 4 to break or be permanently deformed on withdrawal of the outlet assembly 4 from the main body 2.

25

Finally, it will be understood by a person skilled in the art that the present invention is not limited to the described embodiment but can be modified in many different ways within the scope of the appended claims.

23940-1311G

9

CLAIMS:

1. An actuator for an inhaler for delivering medicament by inhalation, comprising:

5 a main body comprising a tubular member for receiving a canister containing medicament and having a valve stem extending therefrom; and

an outlet assembly, as a part formed separately of the main body, comprising a mouthpiece for guiding medicament to the mouth of a user and a nozzle block for receiving the valve stem of the canister and delivering medicament from the canister into the mouthpiece; wherein

10 the actuator belongs to a range of inhaler actuators,

the outlet assembly is a common part for the range of actuators,

the members of the range of actuators differ by the physical appearance of the main body,

15 the outlet assembly is formed such that it comprises all parts of the actuator that come into contact with the medicament during normal use,

the main body and the outlet assembly are provided with complementary snap catch members so as to snap-fit together, and

20 the tubular member is provided with a lateral opening at one end of the tubular member for receiving the outlet assembly at an angle transverse to the length the tubular member.

2. The actuator according to claim 1, wherein members of the range of actuators differ in that their respective main bodies are made of materials having different constitution.

25 3. The actuator according to claim 1 or claim 2, wherein members of the range of actuators differ by the color of their respective main bodies.

23940-1311G

10

4. The actuator according to any one of claims 1 to 3, wherein members of the range of actuators differ by the surface finish of their respective main bodies.

5. The actuator according to any one of claims 1 to 4, wherein
5 members of the range of actuators differ by the decoration of their respective main bodies.

6. The actuator according to any one of claims 1 to 5, wherein members of the range of actuators differ by the shape of their respective main bodies.

10 7. The actuator according to claim 6, wherein the main body is given a particular shape that appeals to a specific patient group.

8. The actuator according to claim 6, wherein the main body is shaped to resemble an object other than an actuator for an inhaler.

15 9. The actuator according to claim 8, wherein the main body is shaped to resemble an animal, a cartoon figure, a plant, a fruit, a toy, a car, or an electronic device.

10. The actuator according to any one of claims 6 to 9, comprising a protection cap to be placed over the mouthpiece of the outlet assembly, said cap being an integrated part of the particular shape in the protecting position.

20 11. The actuator according to any one of claims 1 to 10, wherein the main body comprises attachment means for a key strap, a belt strap or a wrist strap to enable it to be carried around the neck or the wrist of the patient.

25 12. The actuator according to any one of claims 1 to 11, wherein the main body is formed so as to only allow insertion of certain canisters, depending on the medicament contained therein.

13. The actuator according to any one of claims 1 to 12, wherein the outlet assembly is formed as a single integral moulding.

23940-1311G

11

14. The actuator according to any one of claims 1 to 13, wherein the main body is provided with an outlet opening for receiving the outlet assembly in a position wherein the mouthpiece extends outside the outlet opening and the nozzle block is arranged in position for receiving the valve stem of the canister.

5 15. The actuator according to any one of claims 1 to 14, wherein the snap catch members of both the main body and the outlet assembly are arranged inside the actuator in the assembled state.

16. The actuator according to any one of claims 1 to 15, wherein at least a part of the outlet assembly is configured so as to deform on withdrawal of the outlet assembly from the main body so as to prevent re-use of the inhaler.

10

17. The actuator according to any one of claims 1 to 16, wherein at least a part of the outlet assembly is configured so as to deform and break on withdrawal of the outlet assembly from the main body so as to prevent re-use of the inhaler.

15 18. The actuator according to any one of claims 1 to 17, wherein the nozzle block is connected and supported by the mouthpiece providing a substantially free flow of air about the nozzle block.

19. The actuator according to claim 18, wherein the nozzle block is attached to the mouthpiece by a connection having at least one member connecting a lower part of the mouthpiece with a lower part of the nozzle block and at least one member connecting an upper part of the mouthpiece with an upper part of the nozzle block, leaving therebetween an open path for flow of air during inhalation.

20

20. The actuator according to any one of claims 1 to 19, further comprising one or both of a breath actuation mechanism and a compliance monitor.

25

21. The actuator according to claim 20, wherein the compliance monitor is a dose counter.

23940-1311G

12

22. The actuator according to claim 20 or claim 21, wherein the main body comprises one or both of the breath actuation mechanism and the compliance monitor.

5 23. The actuator according to any one of claims 1 to 22, wherein the outlet assembly is provided in two or more configurations.

24. The actuator according to claim 23, wherein the outlet assembly configuration differs by the orifice size in the nozzle block.

10 25. The actuator according to claim 23 or claim 24, wherein the two or more outlet assembly configurations each can be used with the whole range of main bodies.

26. The actuator according to any one of claims 23 to 25, wherein the outlet assembly of one specific configuration is limited to be used with a specific range of actuator housings.

15 27. The actuator according to any one of claims 23 to 26, wherein the different outlet assembly configurations differ in physical appearance.

28. The actuator according to any one of claims 23 to 27, comprising a protection cap to be placed over the mouthpiece of the outlet assembly wherein the different outlet assembly configurations are identified by the physical appearance of the protection cap.

20 29. An inhaler comprising the actuator according to any one of claims 1 to 28 and a canister containing medicament.

30. The inhaler according to claim 29, wherein the inhaler is a pressurized metered dose inhaler.

25 31. The inhaler according to claim 29, wherein the physical appearance of the main body is indicative of the medicament contained in the canister.

32. The inhaler according to claim 31, wherein the physical appearance of the main body is indicative of the dose delivered.

23940-1311G

13

33. The inhaler according to any one of claims 29 to 32, wherein the physical appearance of the main body is selected by the patient, from the range of main bodies in order to provide a personalized inhaler.

34. A main body of an actuator for an inhaler for delivering medicament
5 by inhalation, comprising

a tubular member for receiving a canister containing medicament and having a valve stem extending therefrom; and for receiving an outlet assembly, as a part formed separately of the main body, comprising a mouthpiece for guiding medicament to the mouth of a user and a nozzle block for receiving the
10 valve stem of the canister and delivering medicament from the canister into the mouthpiece, wherein

the actuator belongs to a range of inhaler actuators,

the outlet assembly is a common part for the range of actuators,

the members of the range of actuators differ by the physical
15 appearance of the main body,

the main body is formed such that it does not come into contact with the medicament during normal use,

the main body is provided with snap catch members that are complementary to snap catch members on the outlet assembly, and

20 the main body is provided with a lateral opening at one end of the tubular member for receiving the outlet assembly at an angle transverse to the length the tubular member.

35. The main body according to claim 34, being made of a material having different constitution than a main body of another member of the range of
25 actuators.

36. The main body according to claim 34 or claim 35, being of a different colour than a main body of another member of the range of actuators.

23940-1311G

14

37. The main body according to any one of claims 34 to 36, being provided with a different surface finish than a main body of another member of the range of actuators.

5 38. The main body according to any one of claims 34 to 37, being provided with a different decoration than a main body of another member of the range of actuators.

39. The main body according to any one of claims 34 to 38, being of a different shape than a main body of another member of the range of actuators.

10 40. The main body according to claim 39, having a particular shape that appeals to a specific patient group.

41. The main body according to claim 39 or claim 40, being shaped to resemble an object other than an actuator for an inhaler.

15 42. The main body according to claim 41, wherein it is shaped to resemble an animal, a cartoon figure, a plant, a fruit, a toy, a car, or an electronic device.

43. The main body according to any one of claims 34 to 42, comprising attachment means for a key strap, a belt strap or a wrist strap to enable it to be carried around the neck or the wrist of the patient.

20 44. The main body according to any one of claims 34 to 43, being formed so as to only allow insertion of certain canisters, depending on the medicament contained therein.

25 45. The main body according to any one of claims 34 to 43, wherein it is provided with an outlet opening for receiving the outlet assembly in a position wherein the mouthpiece extends outside the outlet opening and the nozzle block is arranged in position for receiving the valve stem of the canister.

1/5

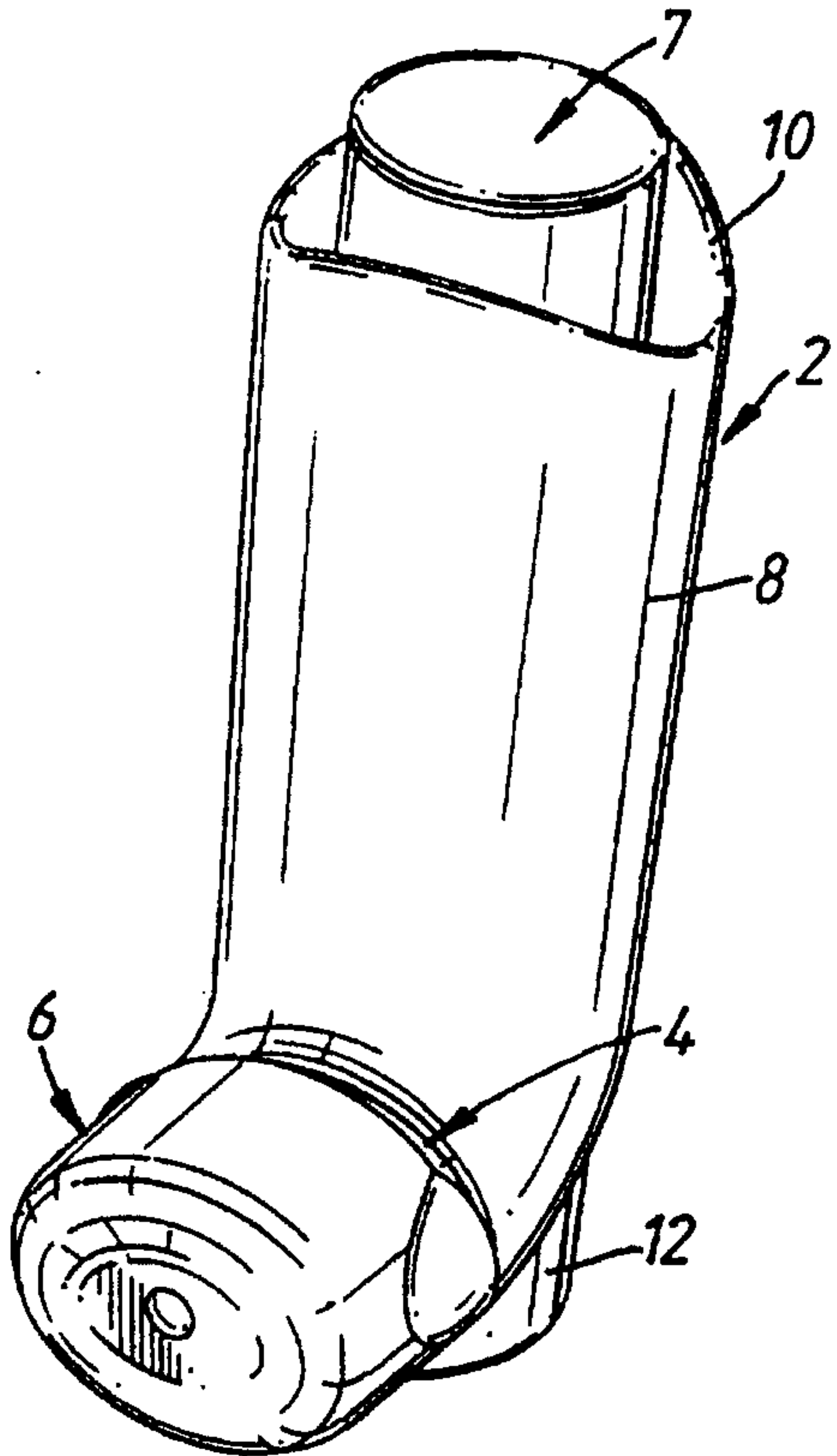

Fig. 1

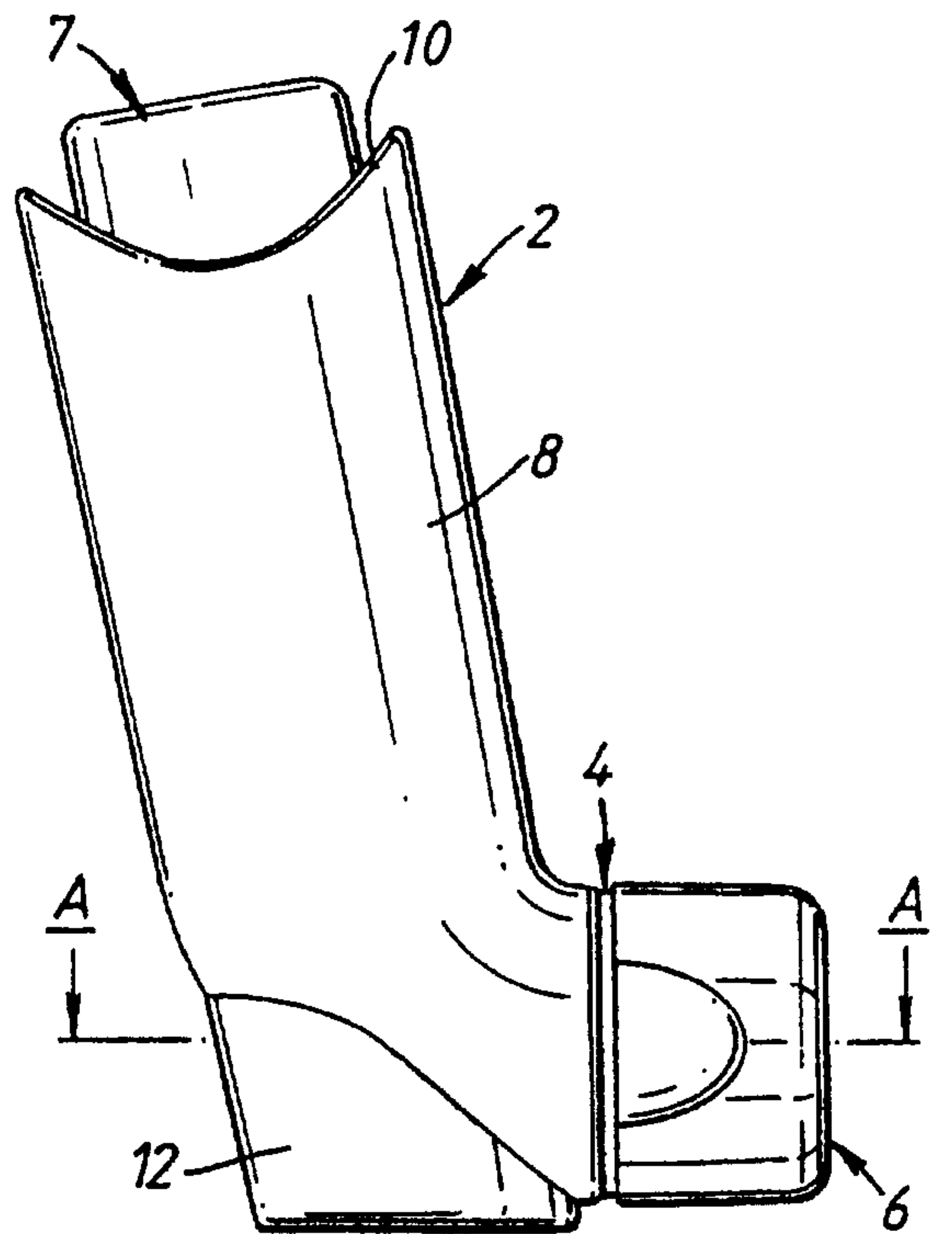

Fig. 2

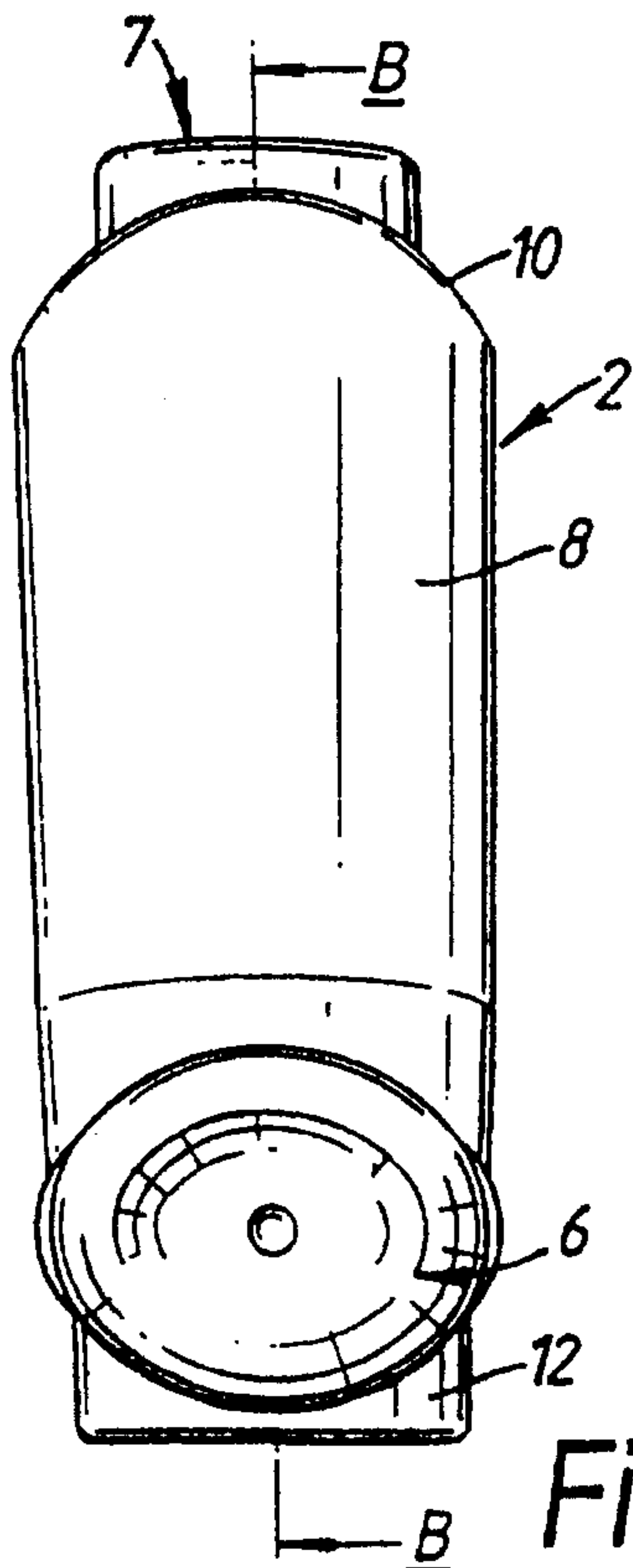

Fig. 3

2/5

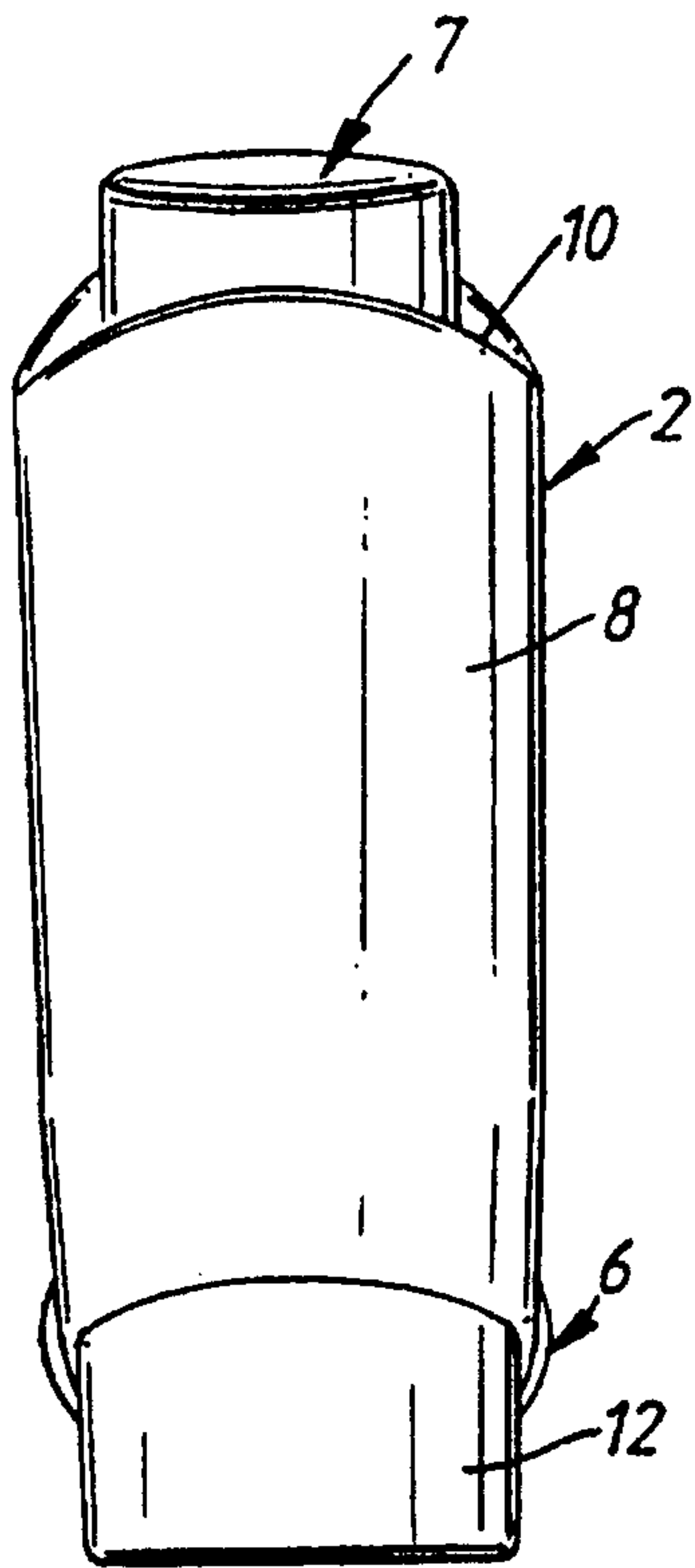

Fig. 4

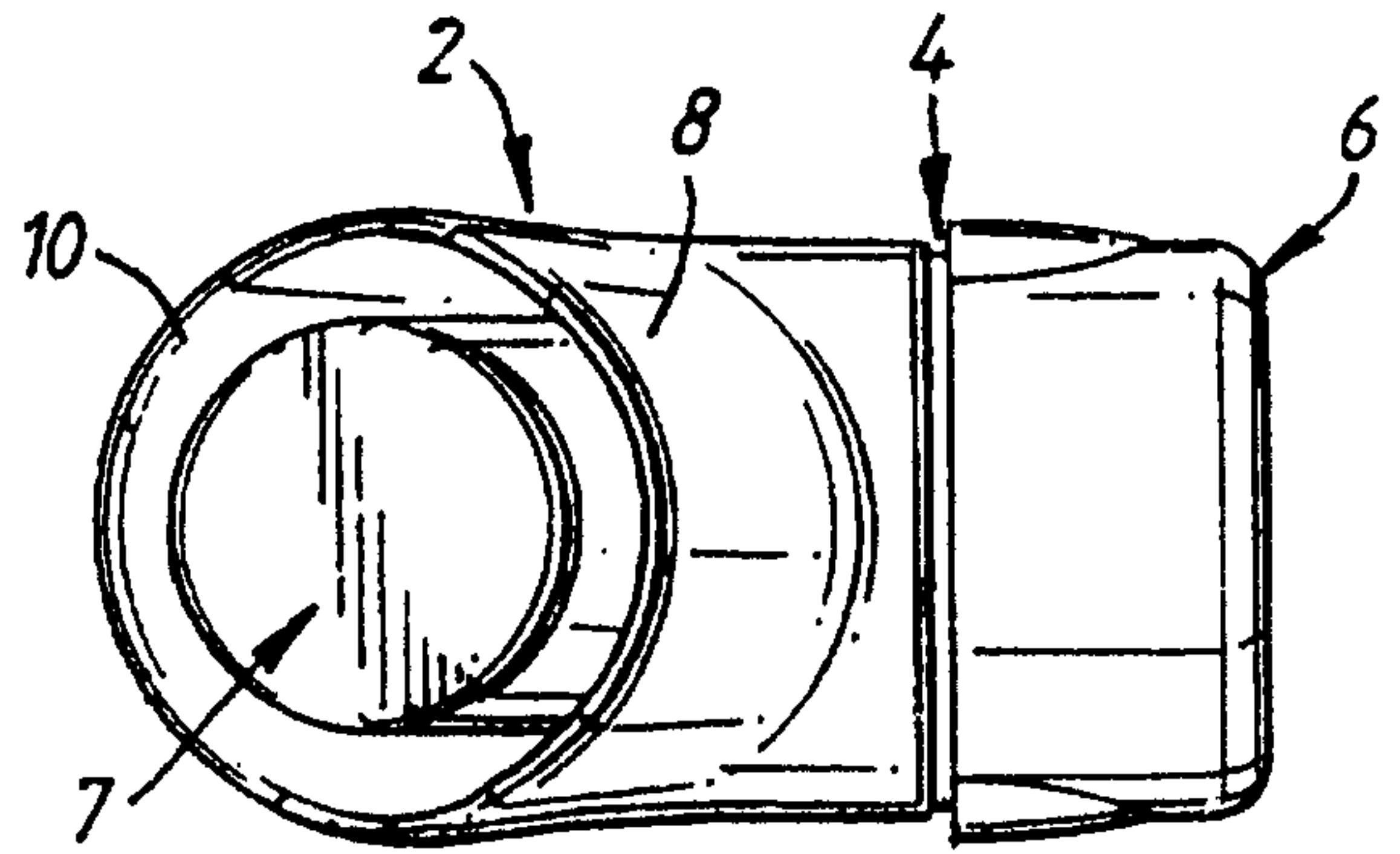

Fig. 5

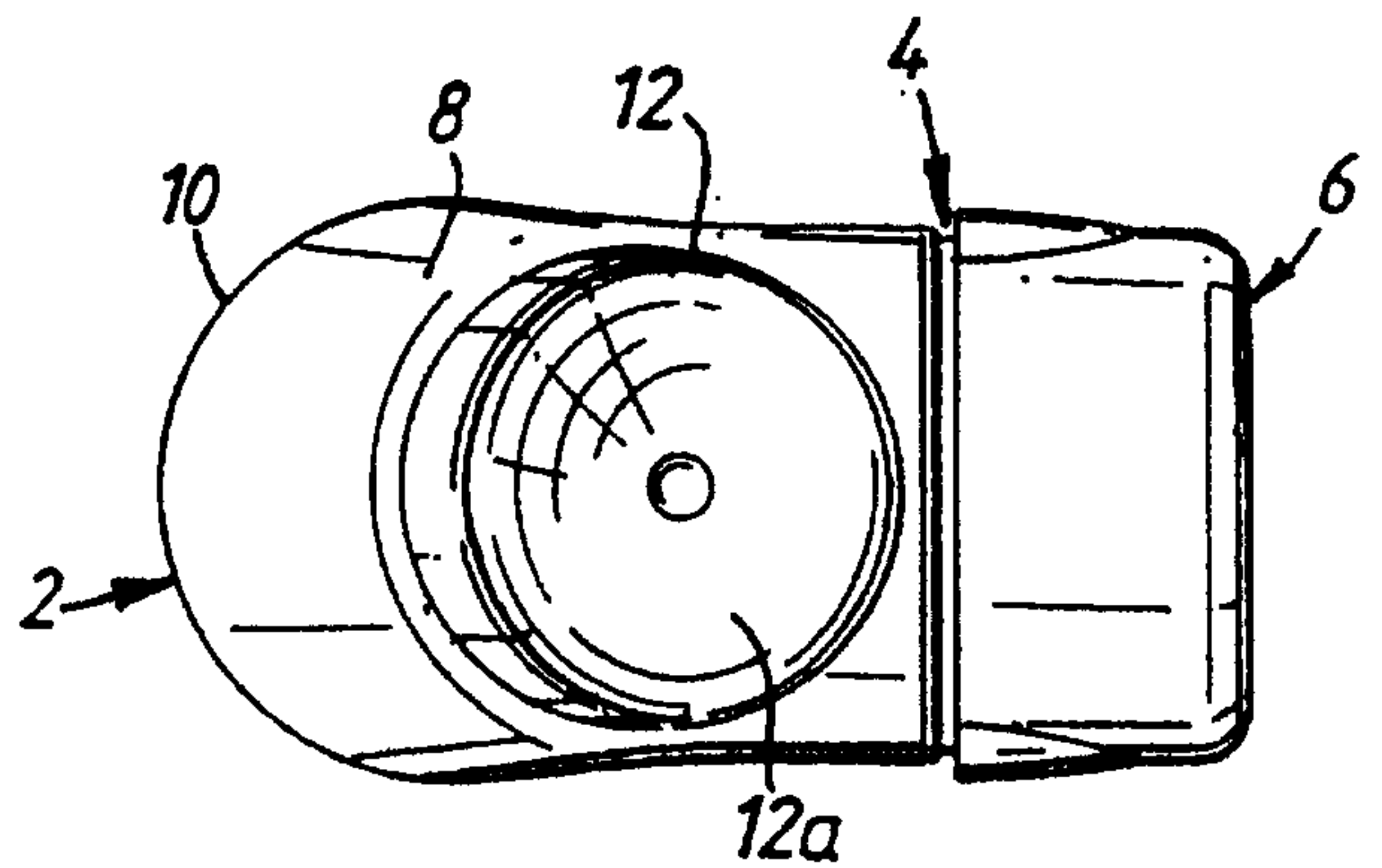

Fig. 6

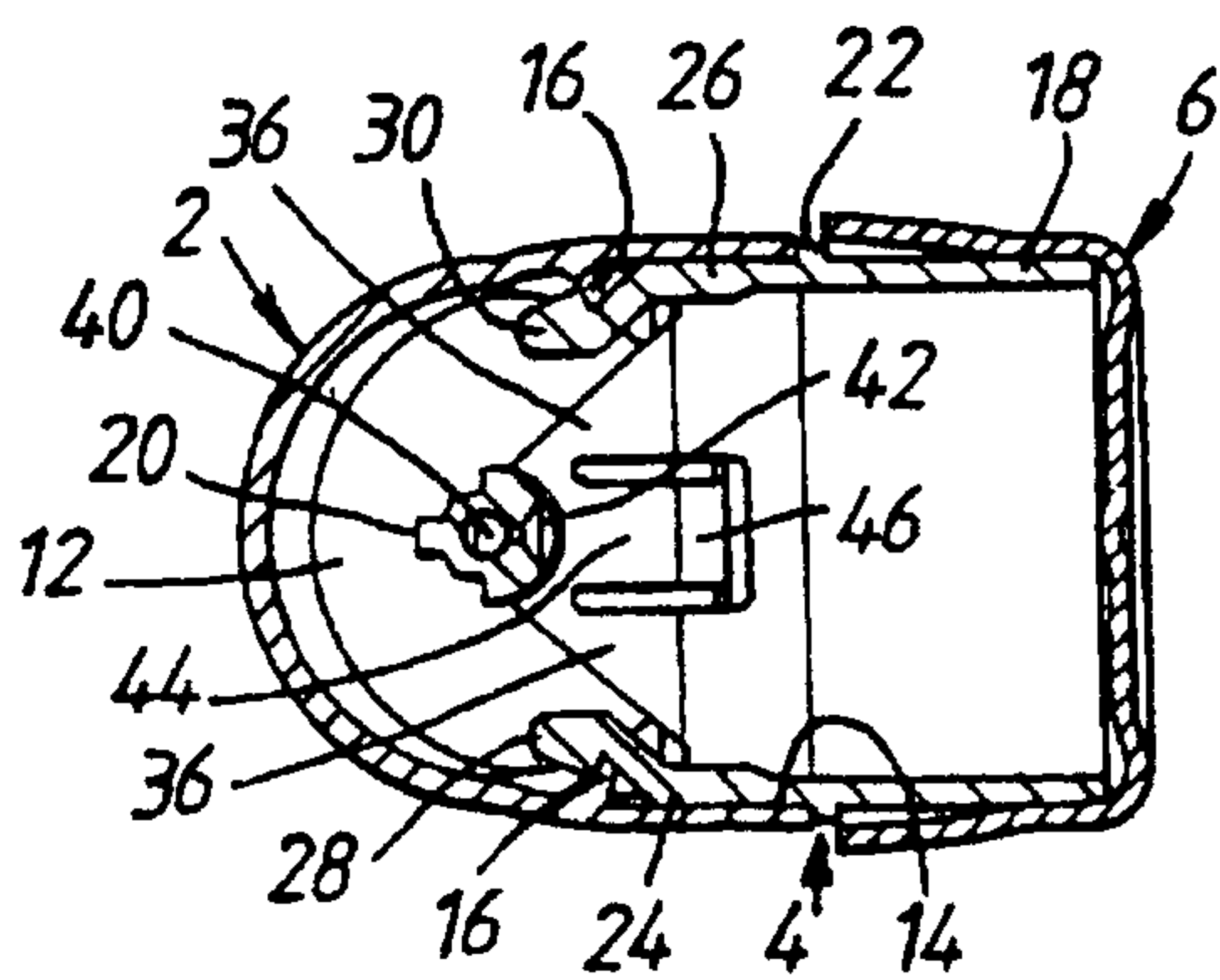

Fig. 7

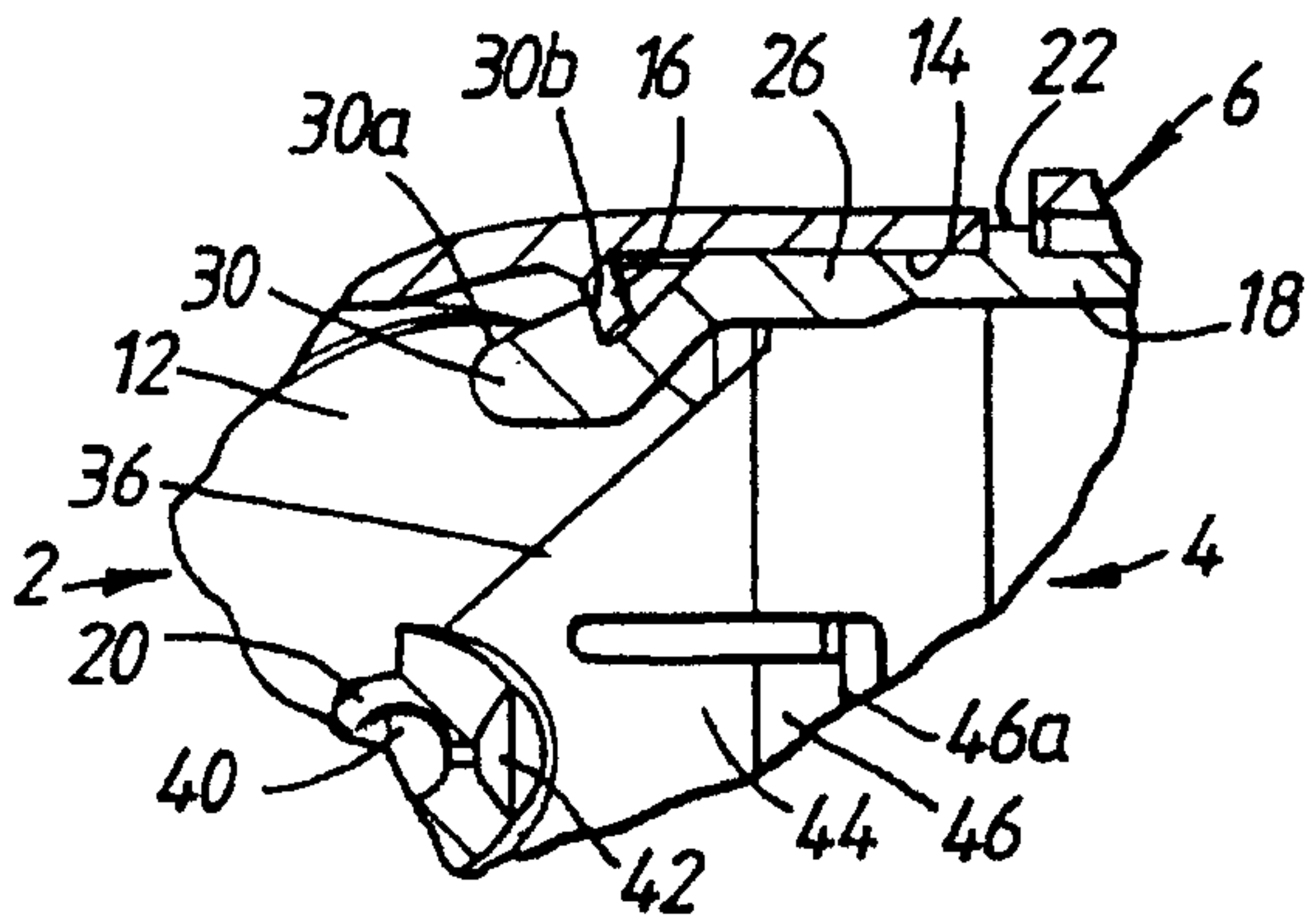

Fig. 8

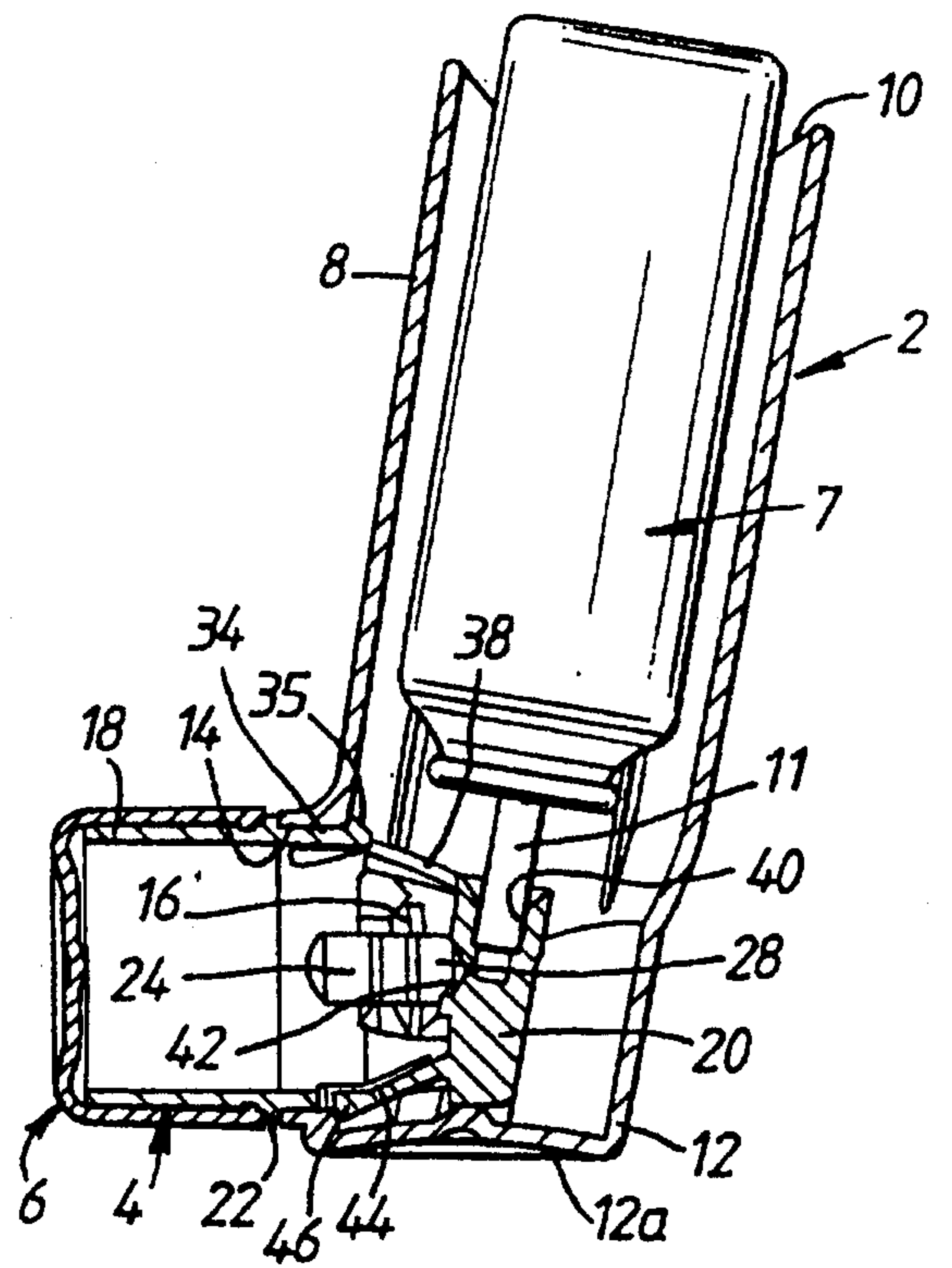

Fig. 9

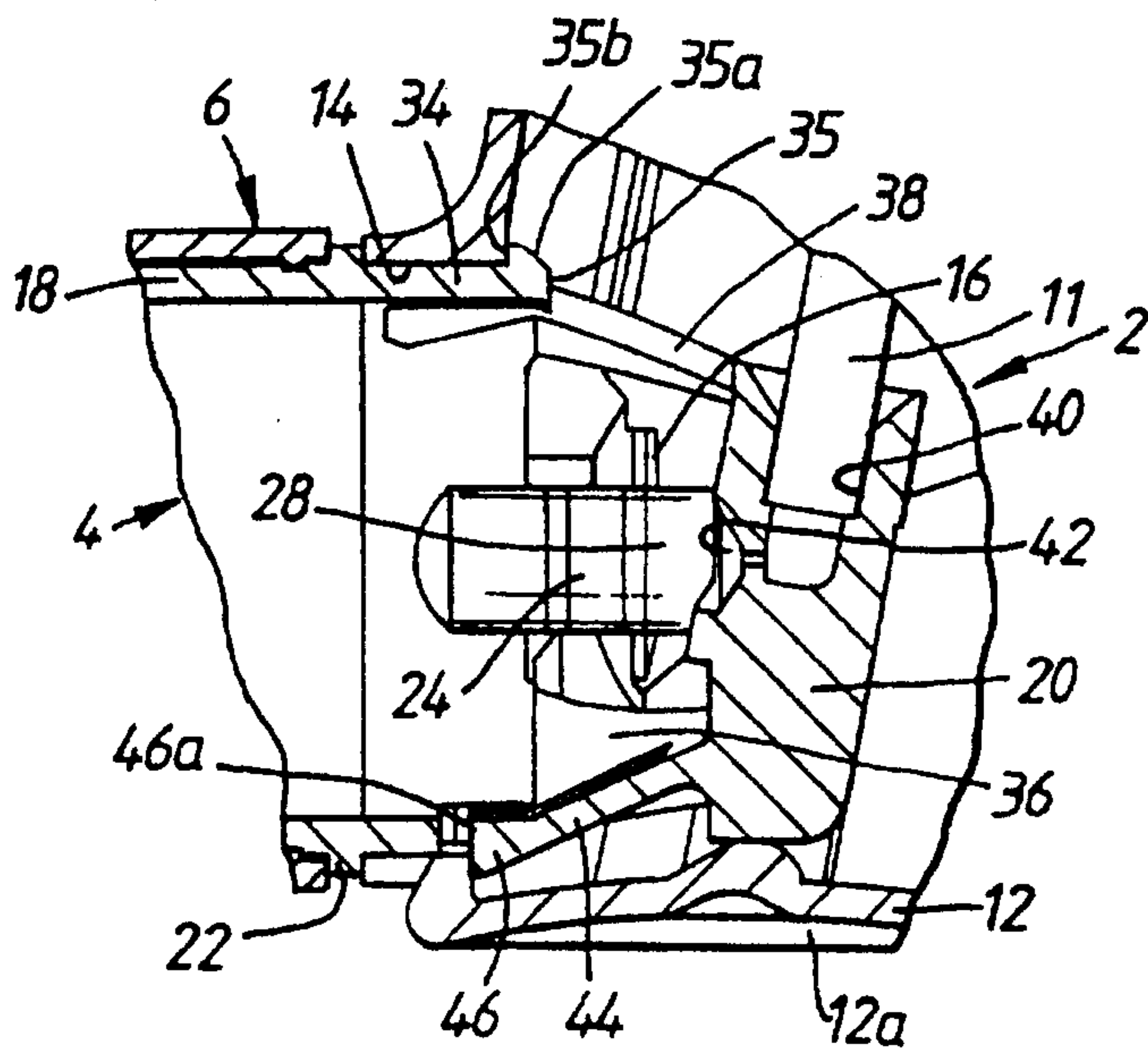

Fig. 10

4/5

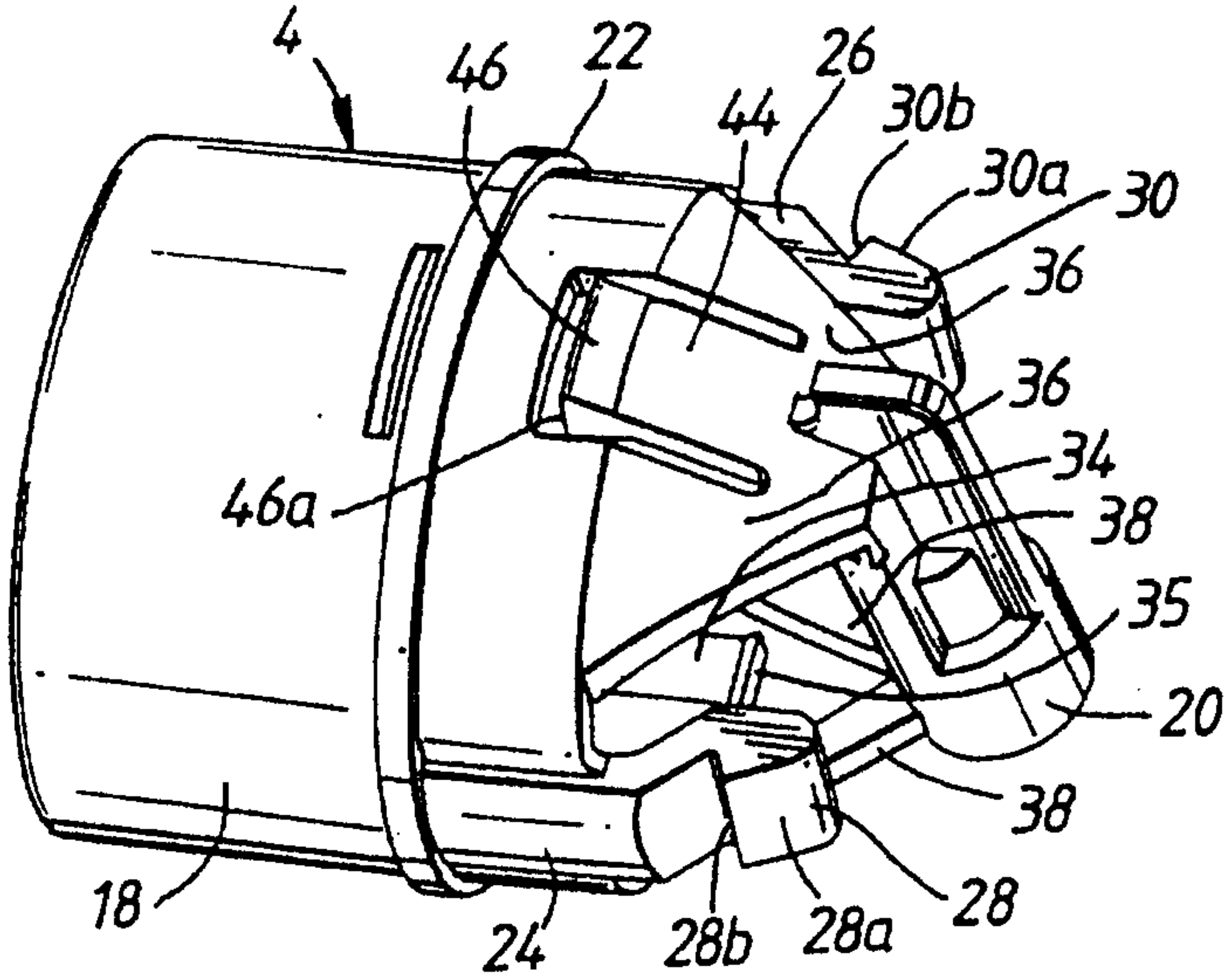

Fig. 11

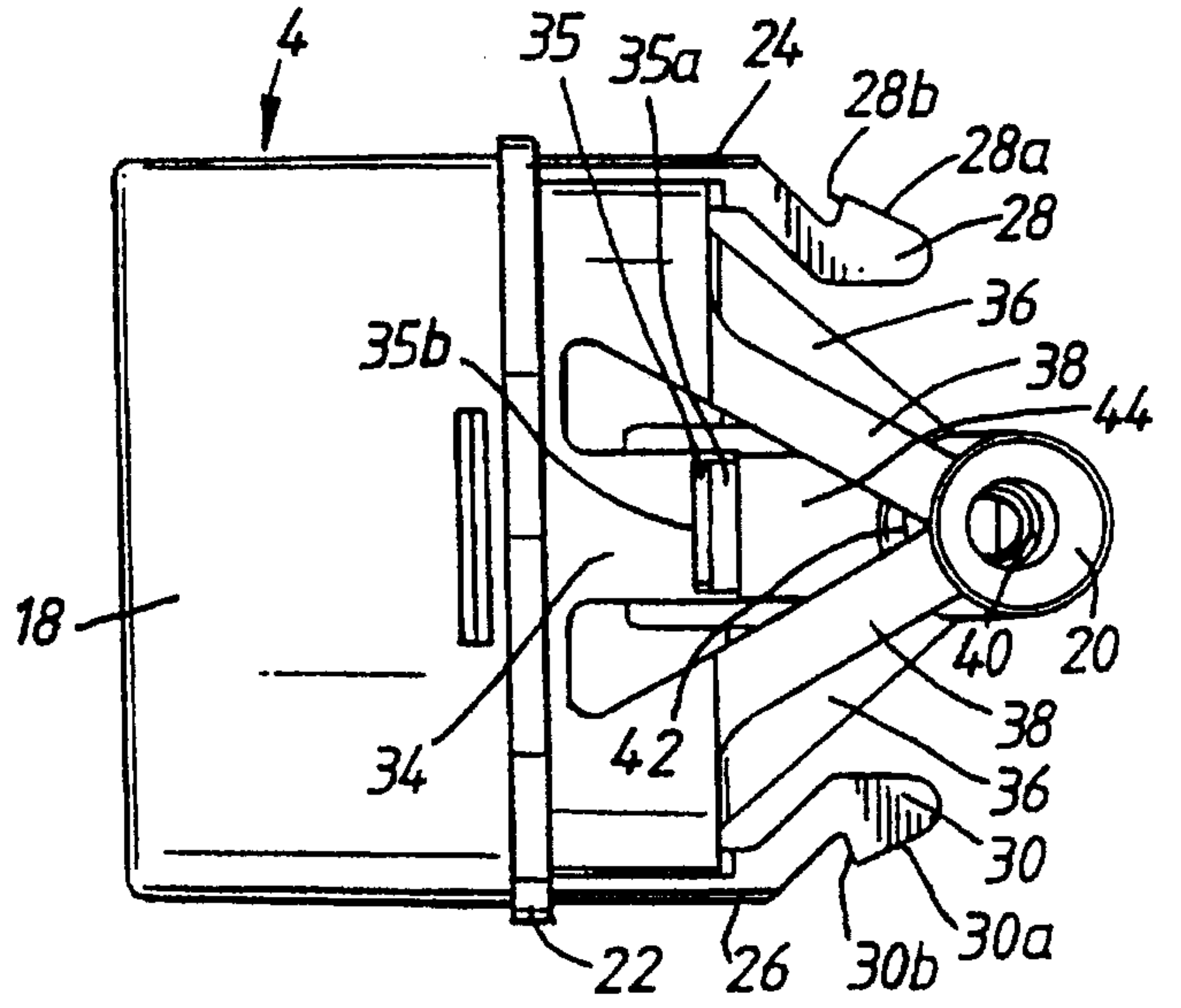

Fig. 12

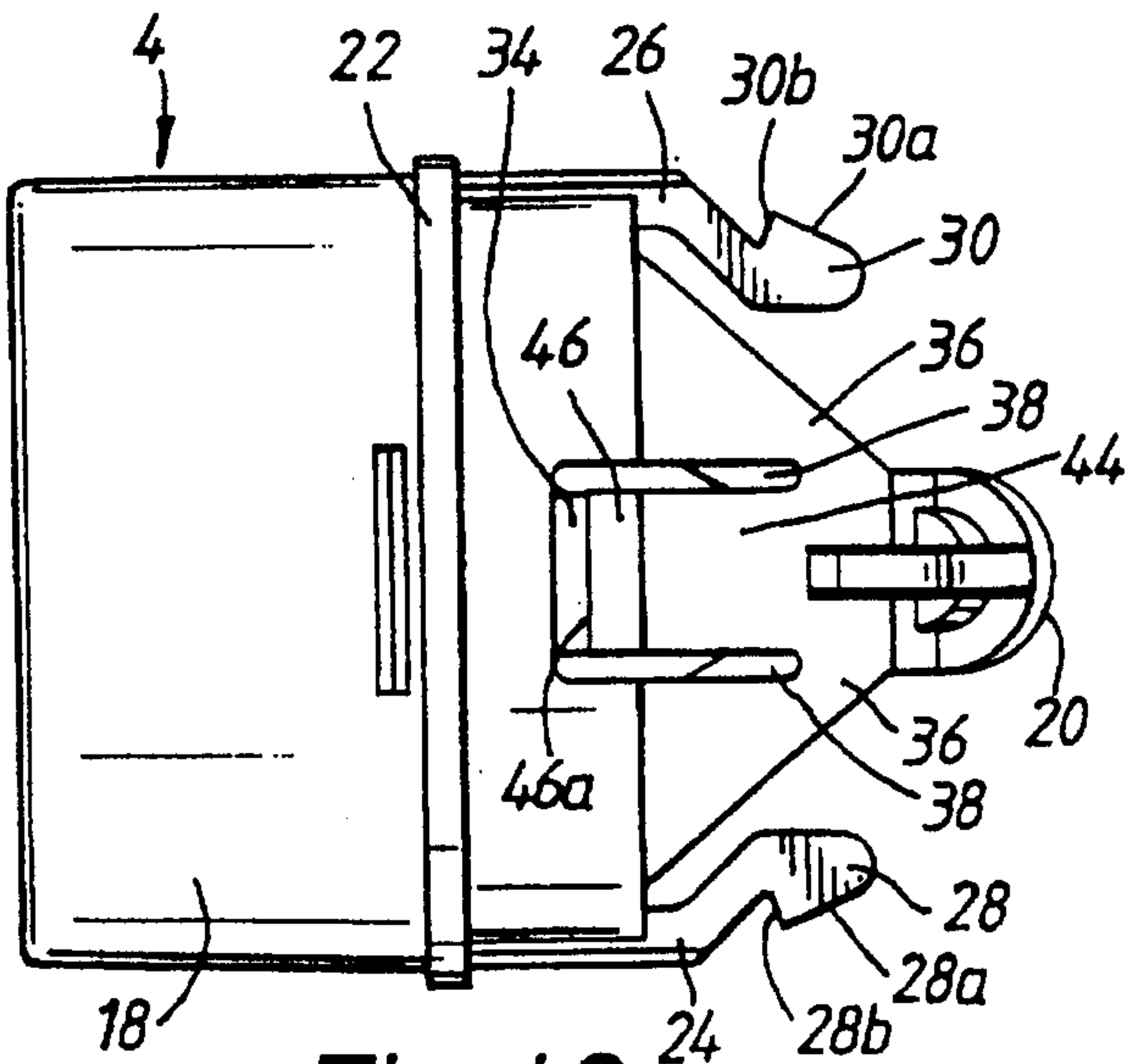

Fig. 13

5/5

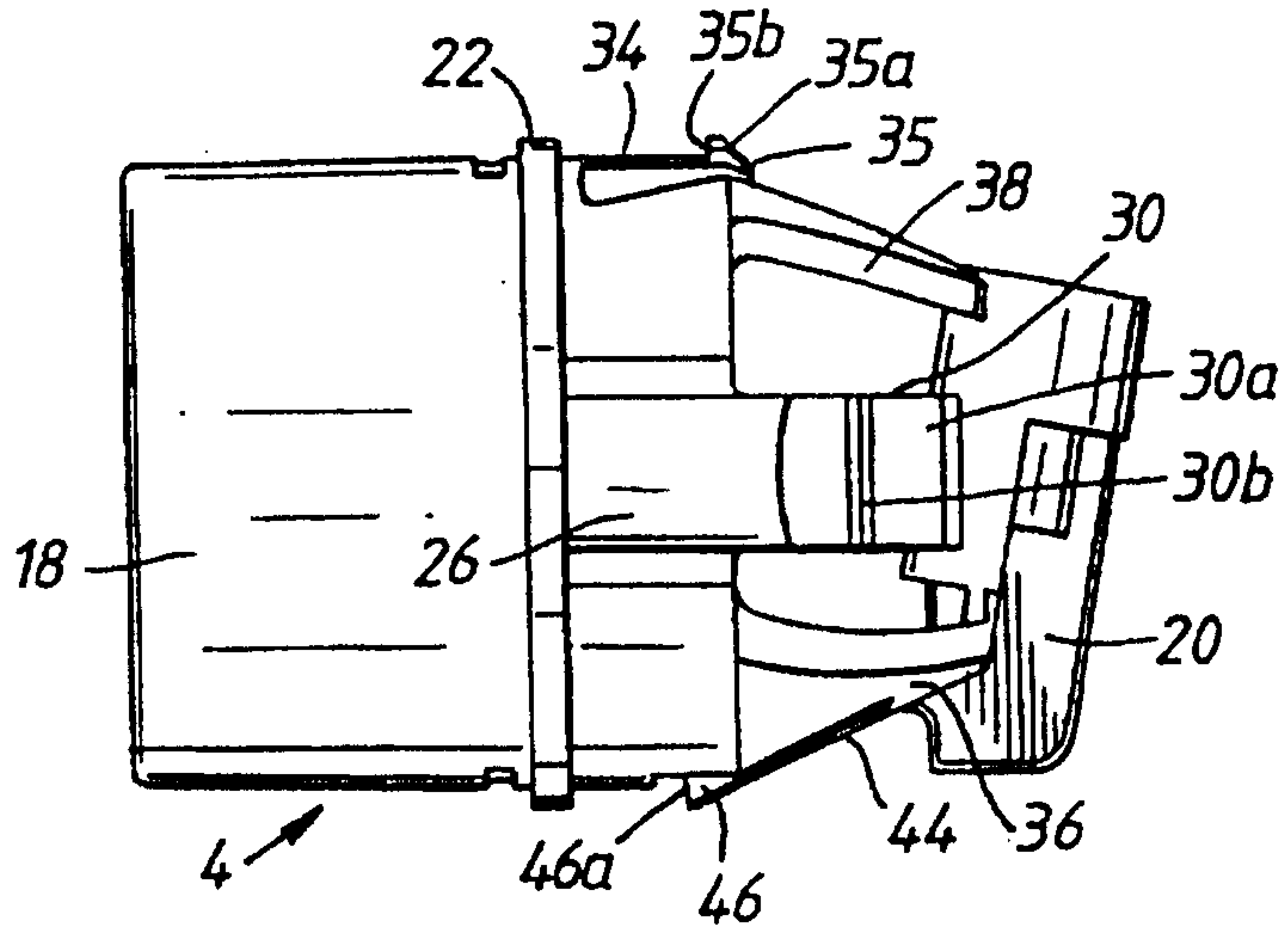

Fig. 14

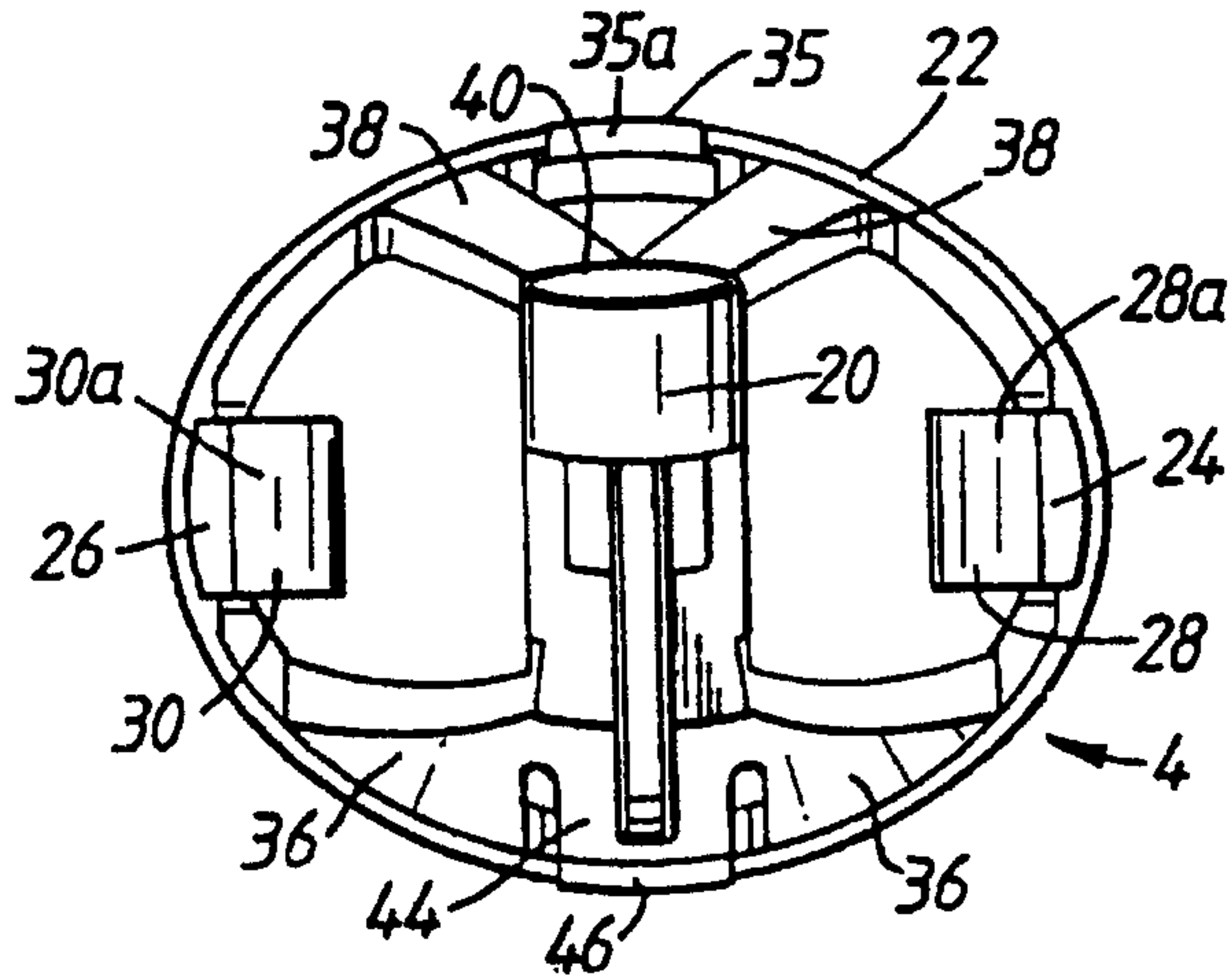

Fig. 15

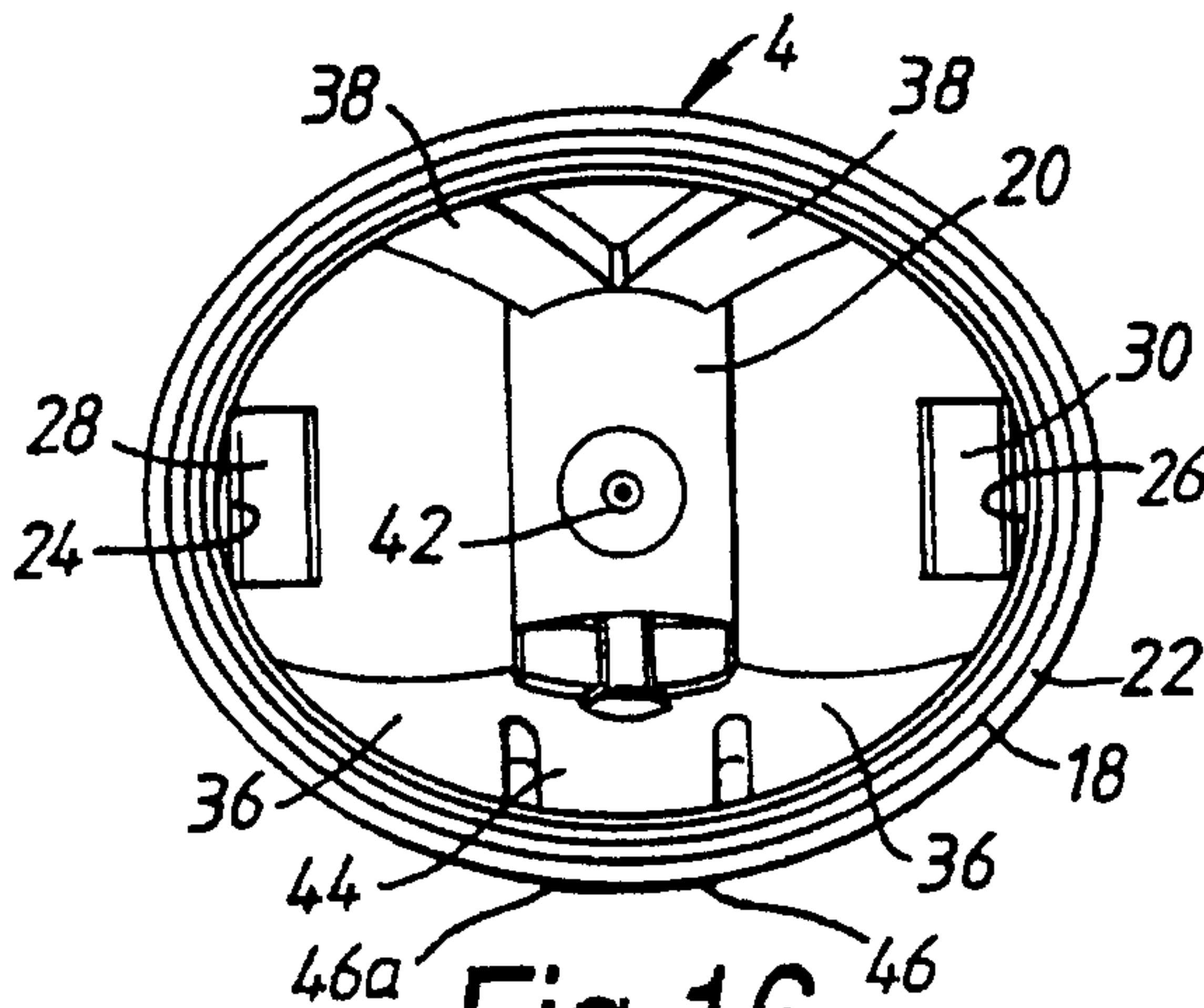

Fig. 16

