



US 20050157486A1

(19) **United States**

(12) **Patent Application Publication**  
**Beuselinck et al.**

(10) **Pub. No.: US 2005/0157486 A1**

(43) **Pub. Date: Jul. 21, 2005**

(54) **ILLUMINATED NOTEBOOK BINDER**

(57) **ABSTRACT**

(76) Inventors: **Steven K. Beuselinck**, Rancho Santa Marg., CA (US); **Robert J. Friedland**, Pasadena, CA (US)

Correspondence Address:  
**ALBERT O COTA**  
**5460 WHITE OAK AVE**  
**SUITE A-331**  
**ENCINO, CA 91316 (US)**

(21) Appl. No.: **10/757,739**

(22) Filed: **Jan. 15, 2004**

**Publication Classification**

(51) **Int. Cl.<sup>7</sup> ..... A47B 19/00**

(52) **U.S. Cl. .... 362/98**

An illuminated notebook binder (10) having a front cover (12) and a rear cover (14) with each cover having inner ends (22) that are attached by an integral spine (28). Encircling the two ends of the spine (28) is a notebook closure flap (42) that is opened and closed by means of an encircling zipper (46). The inner surface (18) of the front cover (12) and/or the rear cover (14) includes a set of compartments (34), pockets (36) and pencil/pen retaining loops (38). The outer surface (16) of the front cover (12) includes indicia (50) that is illuminated by a set of light emitting diodes (DS1-DS5) that are activated by either a first switch (S1) or a second switch (S2). The switches are connected to an electronic control circuit (66) that controls the operation and illumination of the indicia (50). The circuit (66) is housed in an enclosure (64) that is attached to the inner surface (18) of the front cover (12) opposite the indicia (50).

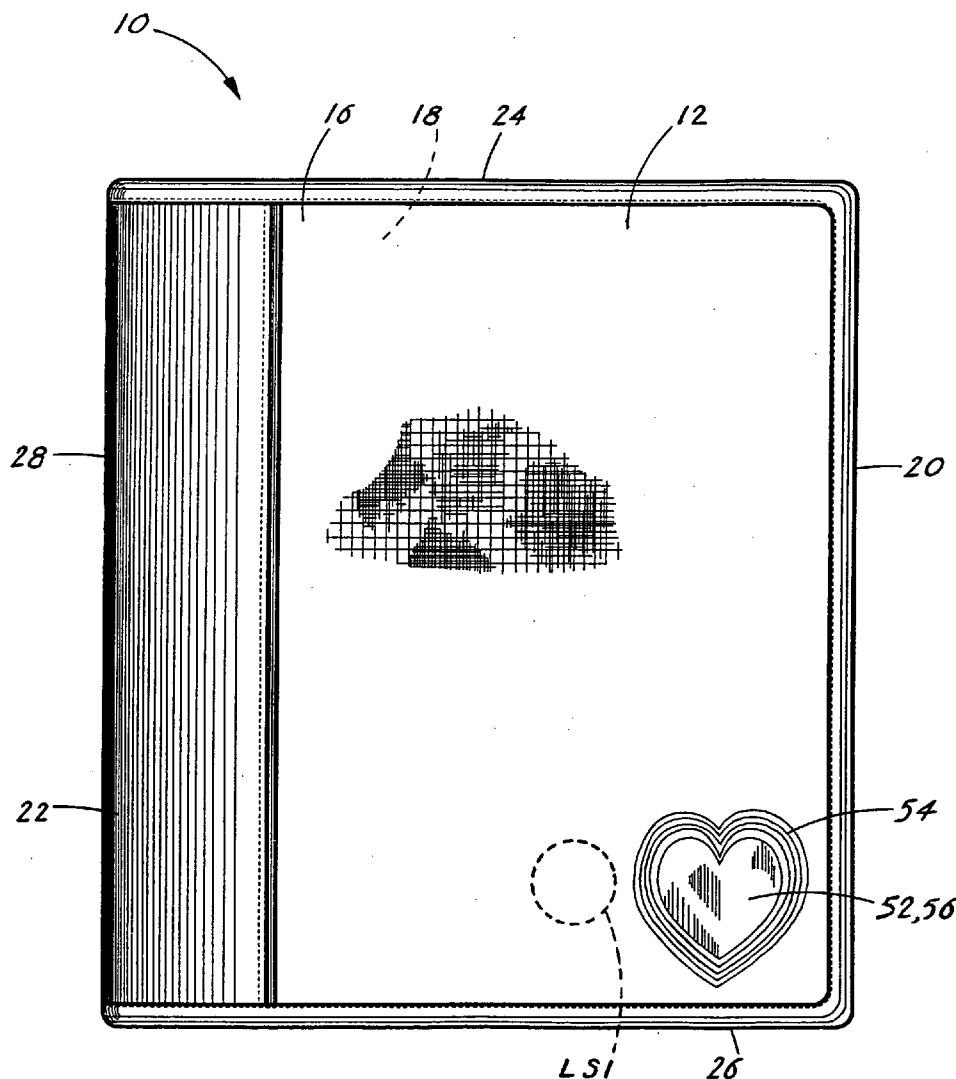

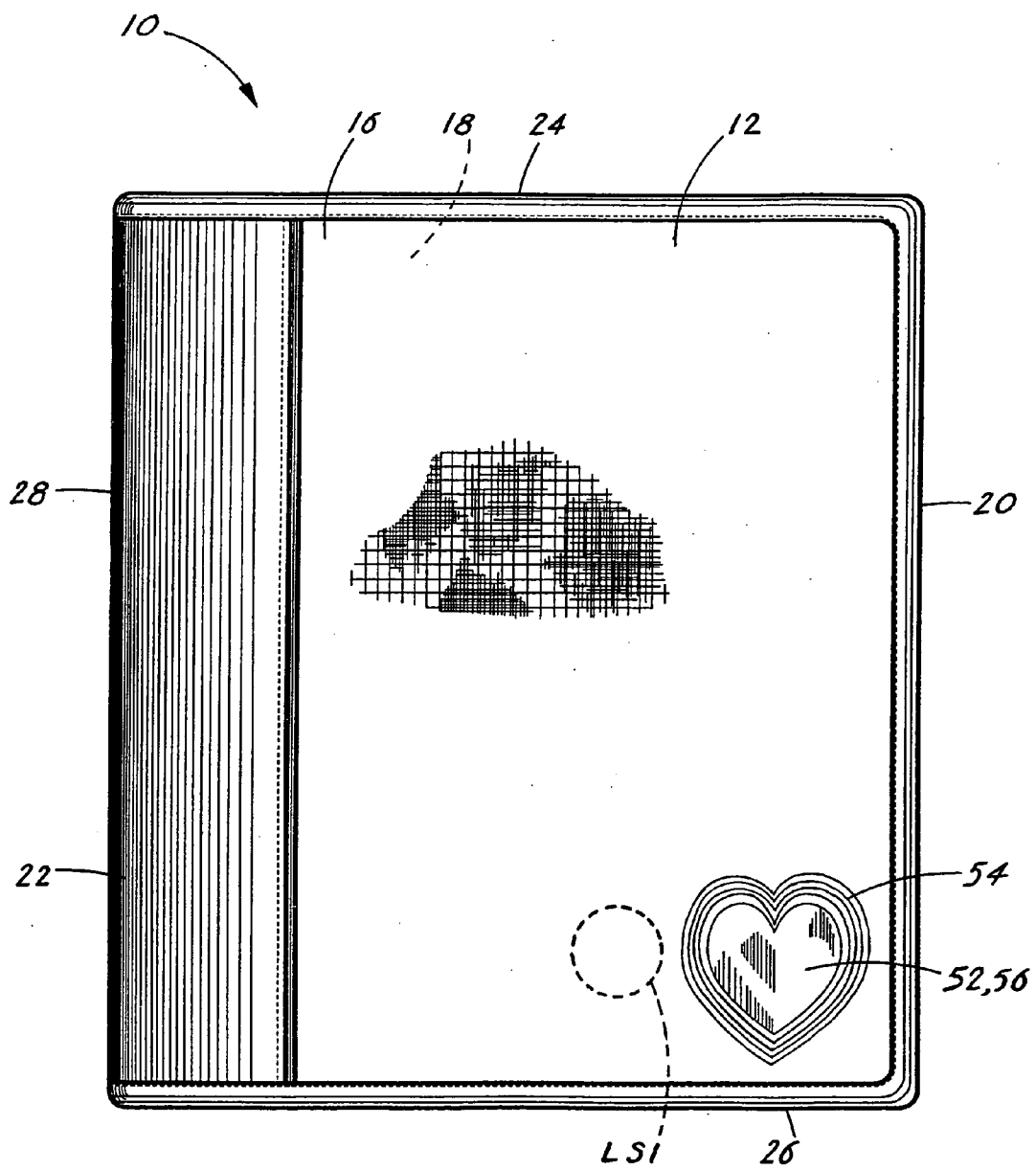

FIG. 1

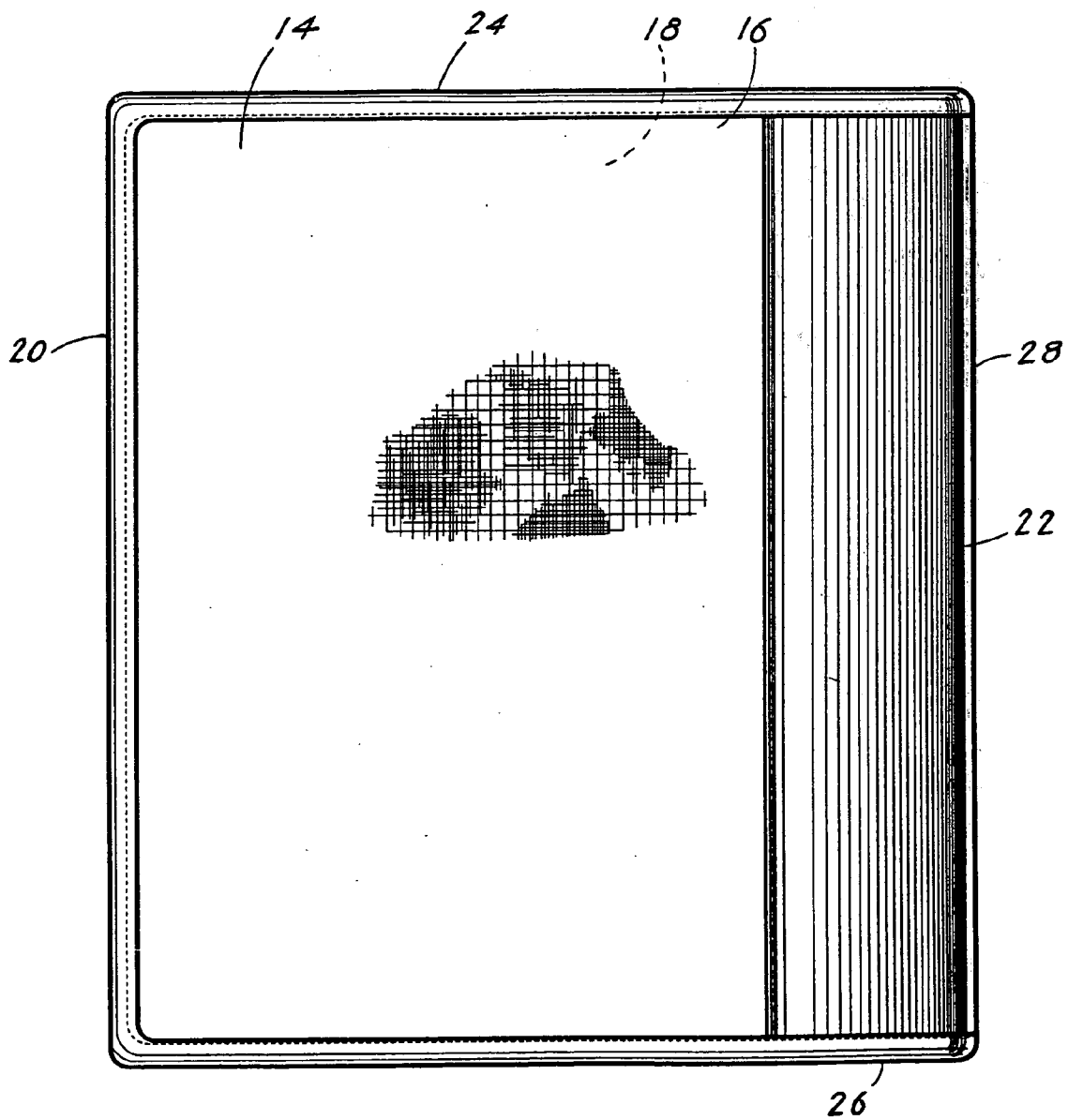

FIG. 2



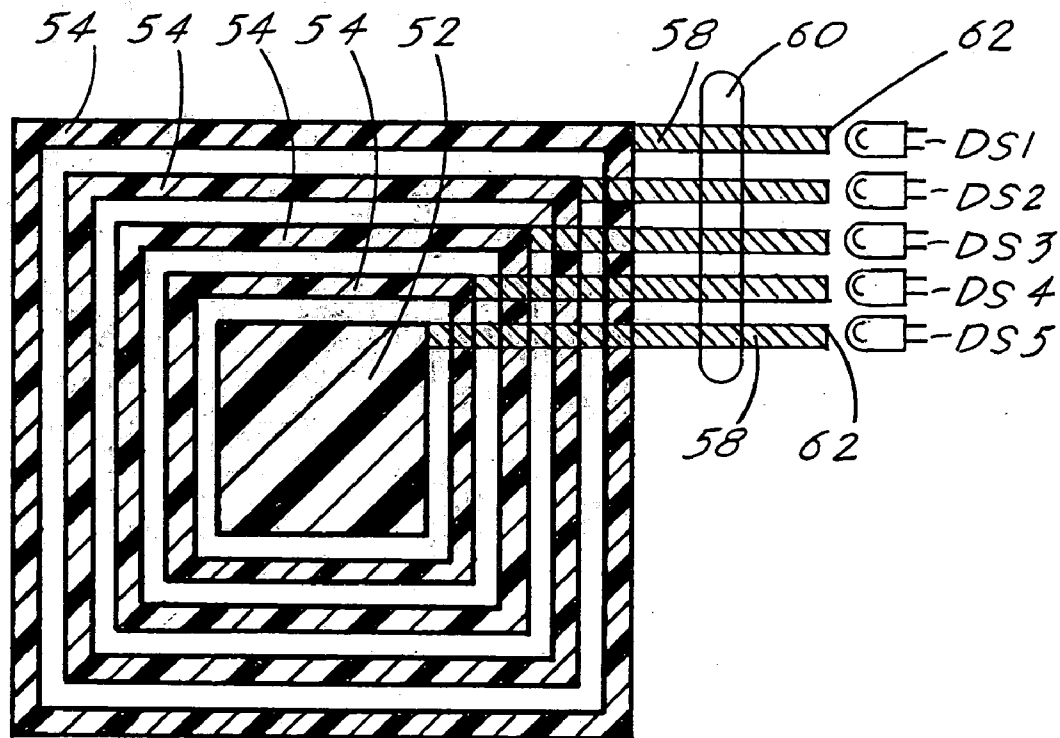

FIG. 4

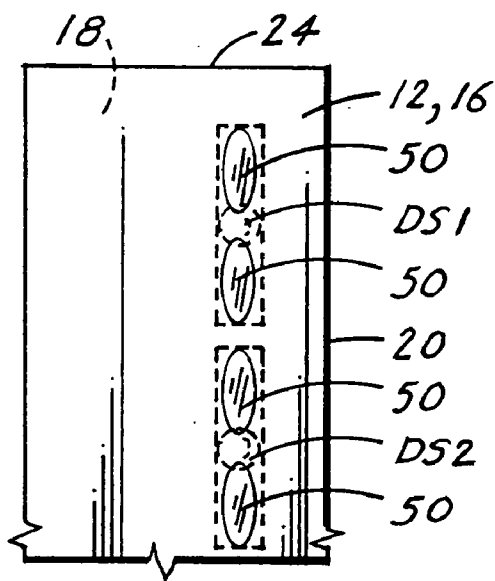

FIG. 5

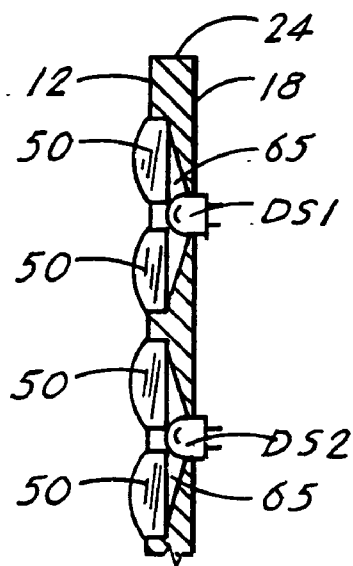

FIG. 6

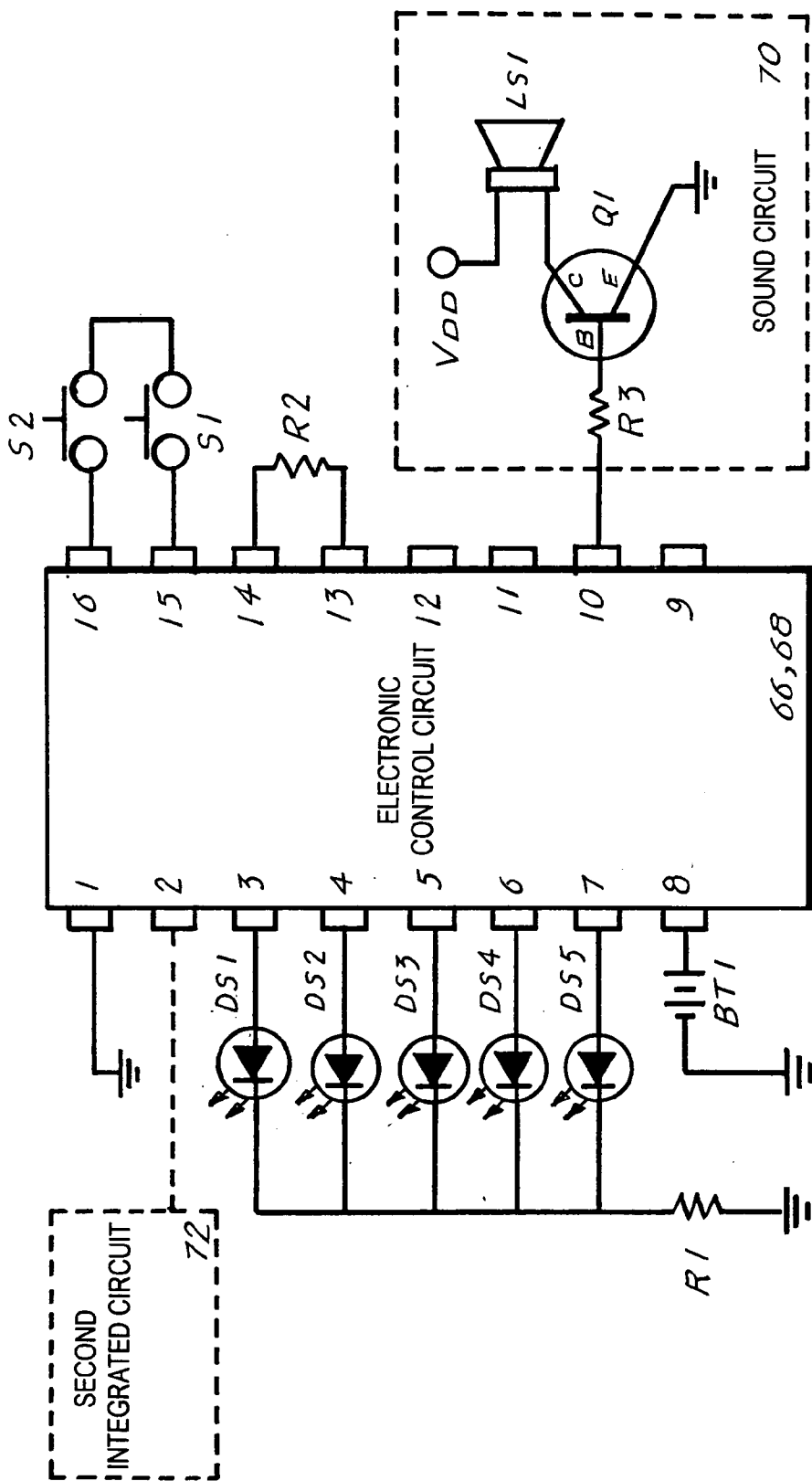

FIG. 7

**ILLUMINATED NOTEBOOK BINDER**

**TECHNICAL FIELD**

[0001] The invention pertains to the general field of notebook binders and more particularly to a notebook binder having on its front cover indicia that is illuminated and controlled by a binder-integral electronic control circuit.

**BACKGROUND ART**

[0002] The use of paper binders, such as three-hole notebooks, has long been a standard practice for students as well as individuals in industrial/commercial establishments. Current notebooks are typically dimensioned to hold and easily remove paper that is loosely held in place by two or three "C", "D" or "slant" rings or other edge binding devices.

[0003] The instant invention, in addition to having a similar basic structure and utility of the current notebooks also has:

[0004] 1. A plurality of compartments, pockets and pencil/pen retaining loops located on the inner surface of the front and/or back covers.

[0005] 2. A closure flap that extends across the open ends of the notebook. The flap, which can be easily opened or closed by means of a zipper, secures and safeguards the contents of the notebook.

[0006] 3. Indicia in the form of a fanciful image or logo that can be illuminated by a set of LEDs. The LEDs are manually energized by a user-controlled switch that is connected to a binder-integral electronic control circuit that further controls the operation of the switch and the LEDs.

[0007] A search of the prior art did not disclose any literature or patents that read directly on the claims of the instant invention. However, the following U.S. patents are considered related:

PATENT NO.	INVENTOR	ISSUED
5,632,566	Korzilius	27 May 1997
5,242,237	Wagner	7 September 1993
4,865,483	Snook	12 September 1989

[0008] The U.S. Pat. No. 5,632,566 discloses a notebook reinforcing device consisting of two flat, rectangular, pre-slotted, backing boards with the anterior backing board containing six receiving strips (hooks). The hooks are affixed in a parallel manner, with an equal number located above and below the centerline. The posterior backing board contains between two and six binding straps. One end of the binding strap is permanently affixed to the posterior backing board, with an equal number affixed above and below the centerline, and affixed to the hooks attached to the anterior backing board.

[0009] The U.S. Pat. No. 5,242,237 discloses a notebook binder with an integral book band for holding sheets of paper, loose books or other objects affixed to the interior and exterior faces of a cover of the notebook binder. The objects are held against the cover of the notebook binder by the use of an adjustable strap which encircles the objects with two loops that are substantially perpendicular to one another.

[0010] The U.S. Pat. No. 4,865,483 discloses a blow-molded notebook binder that provides protection from mechanical shock and abuse. When antistatic and/or conductive agents are blended into the polymeric material to make up the parison for the notebook binder, protection from electrostatic discharge is also provided.

**DISCLOSURE OF THE INVENTION**

[0011] The illuminated notebook binder in its basic design configuration is comprised of a front and back cover with each cover having an outer surface, an inner surface, an outer end, an inner end, an upper edge and a lower edge. The inner end of the front and back covers are interconnected by an integral, seamless spine that adds to the structural integrity and the aesthetics of the binder. Adjacent the lower or upper corner of the front cover is located indicia that can be illuminated at selectable times.

[0012] The illuminated binder is preferably comprised of a three-ring binder having on the inner surface of the front and/or rear covers a set of pencil and pen retaining loops and a plurality of compartments and pockets that can be utilized to hold various items. One of the pockets is transparent and is dimensioned to safely and visibly hold a CD or a DVD. The binder is also designed to incorporate a notebook closure flap that commences on one end of the spine and continues across the upper edges, the outer ends, the lower edges and terminates on the opposite end of the spine. The closure flap is easily opened and closed by a combination hook and loop fastener or preferably by a zipper.

[0013] The indicia is preferably comprised of a solid central image that can consist of various geometric figures or fanciful images such as a heart. From the border of the central image extends outward a progression of sequential lines that resemble the central image. The central and outward-progressing lines are made of plastic and include an edge that is attached to a light-transfer ribbon that is edge-lighted by a set of LEDs. The LEDs are activated and controlled by an electronic control circuit that is packaged in an enclosure located on the corner of the inner surface of the front cover opposite the indicia.

[0014] The electronic control circuit, which is comprised of a single integrated circuit such as a HOLTEK HT-2884 or a REALTEK RTS951, integrates all the necessary elements to activate and control the operation of the set of LEDs. The electronic control circuit can be designed with two push-button switches, each of which is accessible from the enclosure located on the inner surface of the front cover. When the first switch is pressed, the LEDs automatically illuminate in a selectable sequence. The second switch allows the LEDs to illuminate one LED at a time each time the second switch is pressed.

[0015] In view of the above disclosure, the primary object of the invention is to produce an illuminated notebook binder that is attractive, has added utility by adding to the binder's inner surfaces a plurality of compartments, pockets and pencil/pen retaining loops and that includes on its front cover indicia that can be selectively illuminated by an end user.

[0016] In addition to the primary object of the invention, it is also an object of the invention to produce a notebook binder having illuminated indicia that:

[0017] Can be applied to various sizes and designs of notebooks and other types of books,

[0018] can be illuminated by itself or in combination with various user selected sounds,

[0019] is operated by an off-the-shelf electronic control circuit that requires minimal external components, and

[0020] is cost effective from both a manufacture's and consumer's point of view.

[0021] These and other objects and advantages of the present invention will become apparent from the subsequent detailed description of the preferred embodiment and the appended claims taken in conjunction with the accompanying drawings

#### BRIEF DESCRIPTION OF THE DRAWINGS

[0022] FIG. 1 is an elevational view of the front cover of the illuminated notebook binder showing illuminated indicia located on a corner of the notebook's front cover. An optional loudspeaker is also shown in broken lines.

[0023] FIG. 2 is an elevational view of the rear cover of the illuminated notebook binder.

[0024] FIG. 3 is a perspective view of an illuminated binder consisting of a three-ring binder. The binder is shown in an open configuration showing various compartments, pockets, pencil/pen retaining loops and an enclosure that houses the electronic control circuit.

[0025] FIG. 4 is an elevational-sectional view of a light transfer ribbon having a first end attached to the indicia and a second end, which receives the illumination provided by a set of LEDs.

[0026] FIG. 5 is a partial front elevational view of a front cover having a plurality of illuminated indicia located on the outer surface and adjacent the outer end of the front cover.

[0027] FIG. 6 is an elevational-sectional view of the illuminated indicia shown in FIG. 5.

[0028] FIG. 7 is a block diagram of a typical electronic control circuit connected to various elements that operate a set of LEDs that illuminated the indicia on the notebook binder. The block diagram also shows in broken lines an optional sound circuit and a second integrated circuit.

#### BEST MODE FOR CARRYING OUT THE INVENTION

[0029] The best mode for carrying out the invention is presented in terms of a preferred embodiment for an illuminated notebook binder 10 (hereinafter "INB 10"). The preferred embodiment, as shown in FIGS. 1-5, is comprised of the following major elements: a front cover 12, a rear cover 14, indicia 50 and an electronic control circuit 66 that controls the operation of a set of LEDs DS-1, DS-2, DS-3, DS-4 and DS-5.

[0030] The front cover 12 and the rear cover 14, as shown in FIGS. 1, 2 and 3, are each comprised of an outer surface 16, an inner surface 18, an outer end 20, an inner end 22, an upper edge 24 and a lower edge 26. The inner ends 22 of the front and back covers 12,14 are interconnected by an integral spine 28, as shown best in FIGS. 1 and 2. Preferably,

the INB 10 is comprised of a three-ring binder 32, as shown in FIG. 3, that has on the inner surface 18 of the front cover 12 and/or the rear cover 14 a plurality of compartments 34, pockets 36 and pencil/pen retaining loops 38.

[0031] The three-ring binder 32, as shown best in FIG. 3, is further comprised of a notebook closure flap 42 that encircles the spine 28, and extends across the upper edges 24, the outer ends 20 and the lower edges 26 of the binder 32. The flap 42 is further comprised of a flap closure means 44 that can consist of a complimentary pair of hook and loop fasteners but preferably consists of a zipper 46, as shown in FIG. 3.

[0032] The indicia 50, which can consist of a variety of plastic images, is located on the front cover 12 of the INB 10, preferably at a corner bordered by the lower edge 26 and the outer end 20, as shown in FIG. 1. Likewise, the indicia 50 can also be located on the INB's 10 front cover 12 at a corner bordered by the upper edge 24 and the outer end 20 (not shown). The indicia 50 is illuminated and controlled by the binder-integral electronic control circuit 66, described infra. A typical indicia is comprised of a solid central image 52 that includes a series of sequential lines 54 that resemble and progress outward from the solid central image 52. As shown in FIG. 1, the solid central image 52 and the sequential progressive lines 54 resemble a heart 56, however, any fanciful image or geometric figure, as shown in FIG. 4, can also be utilized. The central image 52 and the sequential progressive lines 54 are each made of a plastic with each segment having attached an outward extending slat 58 that comprises a light-transfer ribbon 60 having outer ends 62, as shown in FIG. 4. The outer ends 62 are positioned proximate to the respective LEDs DS-1 to DS-5 that edge-light the ribbon 60 which in turn, transfers the light from the LEDs to the solid central image 52 and the progressive lines 54.

[0033] Alternatively, as shown in FIGS. 5 and 6, the indicia 50 can be comprised of a plurality of sequential, plastic images located on the outer surface 16 and adjacent the outer end 20 of the front cover 12. On the inner surface 18 of the front cover 12 and behind each pair of plastic images is located an LED cavity 65. The cavity 65 is dimensioned to retain an LED that is substantially centered behind each pair of indicia 50 images. The LEDs are activated and controlled by the electronic control circuit 66.

[0034] The electronic control circuit 66 is placed in an enclosure 64, as shown in FIG. 3, that is located on the corner of the inner surface 18 of the front cover 12 opposite the indicia 50. The circuit 66, which provides the means for selectively energizing the set of LEDs is preferably, as shown in FIG. 7, comprised of a HOLTEK HT-2884 integrated circuit which includes a total of sixteen pins, wherein:

[0035] Pin 1 is power ground,

[0036] Pins 2, 9-12 are not used,

[0037] Pins 3-7 are each connected to the anode of the set of LEDs (DS-1 to DS-5), with the cathode of the LEDs connected to ground via a first resistor R1,

[0038] Pin 8 is connected to a d-c power source that preferably consists of a "coin cell battery" (BT-1) that has an output ranging from 2.4 to 3.3 volts d-c,



[0039] Pins 13 and 14 are connected across a second resistor (R2) that is selected to set the activation time for the set of LEDs,

[0040] Pin 15 is connected to a first switch (S1) that when closed, the set of LEDs automatically illuminate in a selectable sequence, and

[0041] Pin 16 is connected to a second switch (S2) that when closed, the set of LEDs illuminate one LED at a time in sequence each time the second switch (S2) is closed.

[0042] The HOLTEK HT-2884 includes an automatic power-off feature that shuts-off the power to the set of LEDs after a pre-selected time has elapsed.

[0043] The INB 10 can also be designed to include an optional sound circuit 70 that is connected to Pin 10 of the HOLTEK HT-2884, as shown by broken lines in FIG. 5. The sound circuit 70 is comprised of an NPN transistor (Q1) having a base (B) that is connected, via a current limiting resistor (R3) to Pin 10, an emitter (E) connected to circuit ground and a collector (C) connected to a loudspeaker (LS1), such as a piezo-electric transducer. The sound circuit 70 can be programmed to provide up to five sounds that are selected by the end user. Additionally, as also shown in FIG. 5, Pin 2 of the HOLTEK HT-2884 integrated circuit is connected internally to an open collector transistor that can be used to trigger a second integrated circuit.

[0044] While the invention has been described in complete detail and pictorially shown in the accompanying drawings it is not to be limited to such details, since many changes and modifications may be made to the invention without departing from the spirit and the scope thereof. For example, in lieu of the HOLTEK HT-2884, a REALTEK RTS 951 integrated circuit can be utilized that allows the use of eight LEDs. Additionally, a light source consisting of electroluminescent panel(s) ELP could also be used. Hence, it is described to cover any and all modifications and forms, which may come within the language and cope of the claims.

1. An illuminated notebook binder comprising:
  - a) a front cover and a rear cover with each cover having:
    - (1) an outer surface,
    - (2) an inner surface,
    - (3) an outer end,
    - (4) an inner end,
    - (5) an upper edge, and
    - (6) a lower edge,
  - b) a spine interconnecting the inner ends of the front and back covers, and
  - c) indicia located adjacent a corner of the front cover, wherein said indicia is illuminated by at least one LED that is activated and controlled by a binder-integral electronic control circuit.

2. The illuminated notebook binder as specified in claim 1 wherein said binder is comprised of a three-ring binder having on the inner surface of the front and/or rear covers a plurality of compartments, pockets and pencil/pen retaining loops.

3. The illuminated notebook binder as specified in claim 1 further comprising a notebook closure flap that encircles the spine extending across the upper edges, the outer ends and the lower edges of said binder, wherein said closure flap further comprises a flap closure means.

4. The illuminated notebook binder as specified in claim 3 wherein the flap closure means comprises a zipper.

5. The illuminated notebook binder as specified in claim 1 wherein said indicia is comprised of plastic images located on said binder's front cover at a corner bordered by the lower edge and the outer end of said binder.

6. The illuminated notebook binder as specified in claim 1 wherein said indicia is comprised of plastic images located on said binder's front cover at a corner bordered by the upper edge and the outer end of said binder.

7. The illuminated notebook binder as specified in claim 5 wherein said indicia is comprised of a solid central image that includes a series of sequential lines that resemble and progress outward from the solid central image.

8. The illuminated notebook binder as specified in claim 7 wherein said solid central figure and the sequential progressive lines resemble a heart.

9. The illuminated notebook binder as specified in claim 8 wherein the central image and the sequential progressive lines are made of plastic with each segment having attached an outward extending slat that comprises a light-transfer ribbon having outer ends, wherein the outer ends are positioned proximate to said LEDs that edge-light the ribbon which in turn, transfers the light from said LEDs to the central image and the progressive lines, wherein said LEDs are activated and controlled by said electronic control circuit.

10. The illuminated notebook binder as specified in claim 1 wherein said indicia is comprised of a plurality of sequential, plastic images located on the outer surface and adjacent the outer end of said front cover, wherein on the inner surface of said front cover and behind each pair of said plastic images is located an LED cavity that is dimensioned to retain an LED that is substantially centered behind each pair of images, wherein said LEDs are activated and controlled by said electronic control circuit.

11. The illuminated notebook binder as specified in claim 1 wherein said electronic control circuit is packaged in an enclosure that is located on the corner of the inner surface of the front cover opposite said indicia.

12. The illuminated notebook binder as specified in claim 1 wherein said electronic control circuit has means for selectively energizing said set of LEDs.

13. The illuminated notebook binder as specified in claim 1 wherein said electronic control circuit is further comprised of a HOLTEK HT-2884 integrated circuit, which includes a total of sixteen pins, wherein:

- a) pin 1 is power ground
- b) pins 2, 9-12 are not used,
- c) pins 3-7 are each connected to the anode of said set of LEDs (DS1-DS5) with the cathode of the LEDs connected to ground via a first resistor (R1),
- d) pin 8 is connected to a d-c power source,
- e) pins 13 and 14 are connected across a second resistor (R2) that is selected to set the activation time for the set of LEDs,

f) pin **15** is connected to a first switch (**S1**) that, when closed, said LEDs automatically illuminate in a selectable sequence, and

g) pin **16** is connected to a second switch (**S2**) that, when closed, said LEDs illuminate one LED at a time in sequence each time the second switch (**S2**) is closed.

**14.** The illuminated notebook binder as specified in claim 13 wherein said HOLTEK HT-2884 integrated circuit includes an automatic power-off feature that shuts-off the power to said LEDs after a pre-selected time has elapsed.

**15.** The illuminated notebook binder as specified in claim 1 wherein said power source comprises a "coin cell battery" (**BT1**) having an output ranging from 2.4 to 3.4 volts d-c.

**16.** The illuminated notebook binder as specified in claim 1 further comprising a sound circuit that is connected to pin **10** of said HOLTEK HT-2884 integrated circuit, wherein said sound circuit is comprised of an NPN transistor (**Q1**)

having a base (**B**) connected via a current limiting resistor (**R3**) to pin **10**, an emitter (**E**) connected to ground and a collector (**C**) connected to a loudspeaker (**LS1**) that is located on the front cover adjacent said indicia.

**17.** The illuminated notebook binder as specified in claim 16 wherein said loudspeaker (**LS1**) is comprised of a piezoelectric transducer.

**18.** The illuminated notebook binder as specified in claim 16 wherein said sound circuit can be programmed to provide up to five sounds that are selected by an end user.

**19.** The illuminated notebook binder as specified in claim 1 wherein pin **2** is connected internally to an open collector transistor that can be used to trigger a second integrated circuit.

\* \* \* \* \*