

June 23, 1970

P. PITT  
SYRINGES

3,516,577

Filed April 10, 1968

2 Sheets-Sheet 1

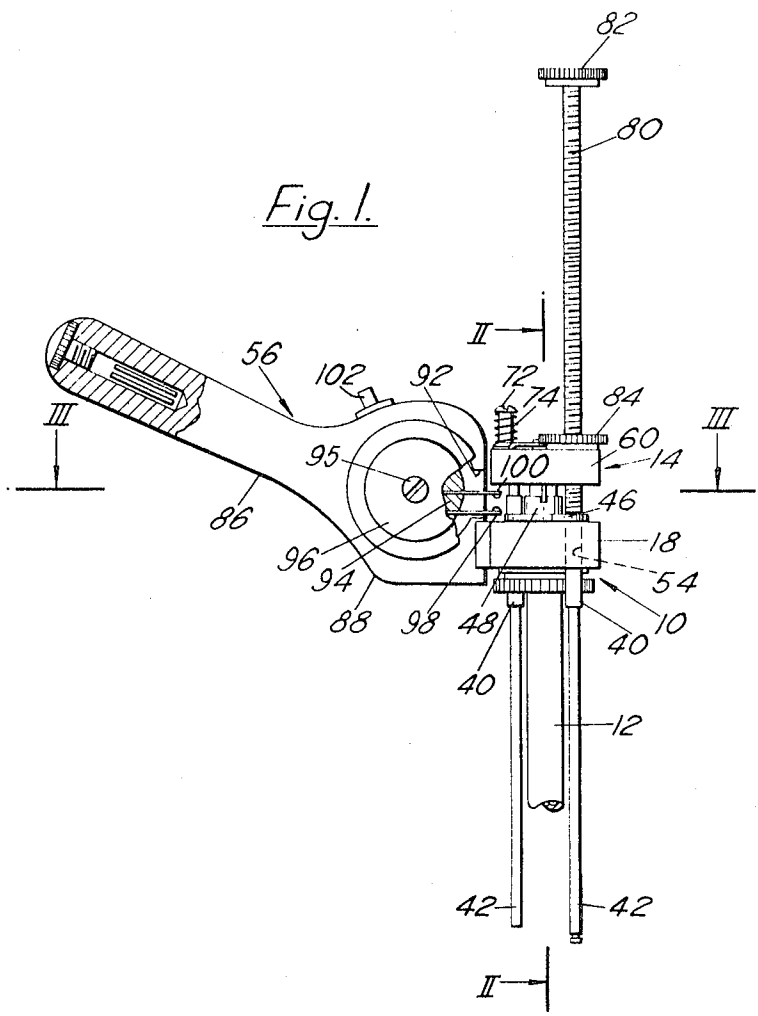

*Inventor*

PETER PITT

By *Friedman & Friedman*  
Attorney



1

3,516,577  
SYRINGESPeter Pitt, London, England, assignor to Shandon  
Scientific Industries Limited, London, England, a  
British company

Filed Apr. 10, 1968, Ser. No. 720,074

Claims priority, application Great Britain, May 23, 1967,  
23,995/67

Int. Cl. G10f 11/06

U.S. Cl. 222—309

9 Claims

2

## ABSTRACT OF THE DISCLOSURE

A metering device for use with a syringe comprise a body member to grip the syringe barrel and a head member which grips the syringe plunger button and is pulled towards the body member by a constant tension spring. A plate on the body member can be moved from a position in which it engages a pin on the head member to hold the members apart, to a position in which the pin is released to allow the members to move together and discharge the syringe. A switch is operated by the members closing to produce an event mark signal.

This invention relates to syringes and is specifically concerned with improving the reproducibility of performance of a syringe usable in chromatography for sample injection.

A syringe may be used in chromatography to inject a sample to be analysed through a septum and into a stream of a relatively inert fluid e.g. gas carrier flowing towards a separation column. The carrier and entrained sample pass through the column and the different constituents of the sample travel at different speeds through the column so that they are spatially separated from one another when they emerge in the effluent leaving the column. The constituents in the effluent are individually detected and a record is kept of their times of emergence. At the end of the chromatographic run the record is compared with a calibration record performed under identical conditions, and the constituents in the sample identified by comparing their time of travel through the column with the times of travel of known constituents during the calibration run.

Under stabilised operating conditions the reproducibility of chromatograms during a series of injections depends on the uniformity of sample delivery into the carrier stream. Normally a measurable quantity of the sample is loaded into a syringe and injected into the carrier by hand. The volume of sample loaded is determined by viewing calibrations on the barrel of the syringe which is transparent for this purpose. Unfortunately two operators will not view the syringe barrel calibrations identically and therefore an operator error is introduced into the volume of the sample drawn into the syringe. When these volumes are small, being of the order of a few micro-litres, the operator error is no longer negligible.

A further source of error stems from the discharge time of the sample into the carrier during an injection. This also varies from one operator to the next and indeed from one injection to the next performed by the same operator. If the sample is injected slowly into the carrier stream it occupies a physically greater length of the stream than if injected rapidly. Therefore the operator attempts to inject the sample quickly. However, the pressure exerted by the operator on the button of the syringe plunger during injection inevitably varies from one injection to another and in attempting to produce as quick an injection as is possible, it is not uncommon for the operator to force the plunger sufficiently hard into the syringe to damage it

when it abuts a stop on completion of the injection. Naturally if the syringe is damaged, further injections have to be made with a different syringe and a new error is introduced. If, on the other hand, the operator injects the sample relatively slowly into the carrier stream there is a danger that the constituents of the sample will not be spatially separated from one another when they emerge in the effluent so that an overlap occurs between the trailing end portion of one constituent and the leading end portion of the following constituent whose detection is therefore made difficult or even impossible.

In accordance with the present invention a metering device for use with a syringe in chromatography comprises a body member for attachment to the syringe barrel, a head member for attachment to the outer end of the syringe plunger and mounted for movement with respect to the body member in opposite directions towards and away from the body member, constant tension spring means acting between the members to urge the members towards each other, means for holding the members a predetermined distance apart, comprising a pin on one of the members extending parallel to said directions and an abutment element movably mounted on the other member, the arrangement being such that in one position the abutment element lies in the path of said pin so as to engage one end of the pin and maintain the members a predetermined distance apart, the abutment element being movable from said one position to another position in which it is out of the path of said pin, so as to permit said constant tension spring means to move the members together to expel a predetermined amount of fluid from a syringe mounted in the device.

Preferably said pin is adjustable longitudinally of said one member, to vary said predetermined distance and hence the amount of fluid to be discharged by a spring mounted in the device.

To use a syringe fitted with the metering device of the invention, the syringe is filled by withdrawing the plunger in conventional manner until the pin is on one side of the abutment element which at this time is in said other position. The abutment element is then moved to said one position and the head member is then moved towards the body member to expel surplus sample fluid from the syringe until the pin end engages the abutment element. The volume of sample fluid in the syringe is now a function of the relative positions of the pin and abutment element which have been preset by the operator and, until altered, ensure that the volume of sample held in the syringe is always the same.

To inject the sample the needle of the syringe is inserted through the septum into the carrier stream and, when in position, the abutment element is moved to disengage the abutment element from the end of the pin. The said means acting between the members move the plunger into the syringe barrel with a predetermined force to expel the sample. The force is naturally so selected that it does not result in damage to the plunger when sample injection is completed, and yet sample injection is accomplished rapidly.

Said means for injecting the sample may be pneumatically operated, for example, by gas bled at a constant pressure from a source supplying a carrier gas. However, it is preferable to form said means from a spring or springs arranged between the head member and body member. In the preferred arrangement a spring device having a constant tension is used such as that commercially known as a "Tensator" spring.

A syringe in accordance with the invention enables a high reproducibility of performance to be obtained when discharging successive identical volumes of a sample into the carrier stream. The chromatograms obtained are

3

therefore more meaningful. The improved reproducibility is obtained because the volume of sample liquid held in the syringe is purely a function of the positions of the pin and abutment element and this volume is discharged at a rate that is independent of the operator's judgement. Thus identical volumes of a sample may be repeatedly drawn into the syringe and injected at identical rates into the carrier stream to conduct a series of chromatographic runs.

A metering device in accordance with the invention will now be described in more detail with reference to the accompanying drawings in which:

FIG. 1 is a side elevation view partly in section of the device and a syringe mounted therein;

FIG. 2 is a section along the line II—II in FIG. 1, and

FIG. 3 is a section along the line III—III in FIG. 1.

The metering device comprises generally a body member 10 removably attached to the rear or outer end of a syringe barrel 12, and a head member 14 removably attached to the plunger 16 of the syringe. The head member is movable towards and away from the body member to operate the syringe.

The body member comprises, in this embodiment, a methyl methacrylate block 18 formed with a screw threaded bore 20 extending from one face which receives the outer end 22 of the syringe barrel and a radial web 24 formed on it. At its inner end the bore 20 terminates in an annular shoulder around a reduced bore 25 extending to the opposite face of the block. The shoulder is provided with a circular groove in which seats a compressible rubber O-ring 26 which is engaged by the web 24. An externally threaded collar 28 made of similar material to the block is a screw fit inside the bore 20 and its internal diameter is slightly larger than the external diameter of the syringe barrel. The collar can therefore be threaded onto the barrel and screwed into the bore 20 to clamp the barrel web 24 against the resilient O-ring 26 as shown in FIG. 2.

One end portion of the block is bifurcated (see FIG. 3) to provide a slot 30 between two fingers 32 and 34. A drum 36 of a Tensator (R.T.M.) spring is mounted on a spindle passing between the two fingers 32 and 34 so that the drum lies between them. A Tensator spring has the property that its tension does not vary as it is extended.

A pair of guide tubes 40 pass through the block at positions lying on diametrically opposite sides of the opening. The guide tubes are made of metal and the ends extend approximately one quarter of an inch from opposite faces of the block 18. Each tube has passing through it a thin steel slider rod 42 which is a close sliding fit in it. At their one ends, the rods 42 are fixed to the head member 14 and the free end of the Tensator spring is also fixed to the head member so that the head member is urged towards the body member and is guided by the rods 42 sliding in the tubes 40.

The face of the body block 18 adjacent the head member is provided opposite its bifurcated end with a movable plate 46 which lies against said face and provides an abutment element. The plate is pivoted about a screw 48, for rotation in its own plane, is in the form of a disc with an arcuate slot or cut-out 50. A trigger arm 52 extends radially away from the disc beyond the side of the block and is disposed to be operable by a finger of an operator's hand gripping a hand grip 56. Beneath the disc the block 18 is provided with a bore 54 parallel to the tubes 42. Thus by moving the trigger arm 52 the cut-out 50 can be moved into and out of register with the bore 54.

The head member 14 comprises a methyl methacrylate block 60 formed with a bore 62 which receives a finger button 64 at the outer end of the syringe plunger. An inwardly directed flange 66 is formed at the end of the bore 62 nearer the block 18, to form a seating for a slotted circular plate 68, the slot of which is slid over

4

the stem of the plunger beneath the button 64. The plate 68 has a portion extending from one side thereof which is of a diameter slightly less than the internal diameter of the flange 66. Thus the plate 68 may be fitted as shown in FIG. 2 or may be reversed so that the finger button 64 can be fitted at two different levels to compensate for finger buttons of different thicknesses. A relatively broad metal leaf spring 70 extends across the top of the bore 62 and it is hinged to one corner of the block by a screw 72 having a spring 74 bearing on the leaf spring 70. A pad 76 is carried by the leaf spring 70 and bears upon the button 64, inside the upper portion of the bore 62 from which it may be removed by flexing the free end of the leaf spring upwardly and then swinging it sideways about its hinged end until the pad and spring are clear of the opening.

The corner of the head block 60 adjacent the hinge is penetrated by a threaded hole through which is screwed the threaded shank 80 of a pin 81 having an externally knurled head 82. The shank 80 passes through a lock nut 84 which can be screwed down onto the top face of the head block to clamp the pin into any position to which it is screwed. The axis of the screw pin is aligned with the bore 54 in the block 18 located beneath the abutment disc 46.

One side of the block 18 is provided with two threaded holes which receive screws securing the pistol grip 56 to the block. The opposite side of the block is also provided with two similar holes to allow the pistol grip to be attached to said opposite side for a left handed operator. The pistol grip enables the device to be comfortably held in the hand when attached to the syringe.

The pistol grip 56 comprises, as shown in FIG. 1 a stem portion 86 and an enlarged portion 88 adjacent the block 18 which is provided with a cylindrical cavity 90 extending into the hand grip from one side thereof. A slot 92 extends radially from the cavity adjacent the block 18. Within the cavity is housed a switch assembly mounted on a central boss 94 within the cavity integral with a circular disc 96 which abuts the side of the portion 88 and conceals the cavity 90. The boss 94 is supported and gripped by a screw 95. For convenience the head of the screw 95 is shown in the drawings as being on the same side as the disc 96. However, in practice the screw 95 is entered through a smooth bore in the hand grip from the other side thereof and screwed into the boss 94. The switch assembly comprises a fixed contact 98 fixed to the boss 94 and extending through the slot 92 to a position adjacent the block 18, and a moving contact 100 comprising a resilient arm fixed at one end to the boss 94 and extending through the slot 92 to a position adjacent the end of the contact 98. The contacts are connected by suitable flexible leads (not shown) within the cavity 90 to a co-axial socket 102 fixed to an outer edge of the portion 88. It will be seen that during operation of the device, as the block 60 approaches the block 18 it engages the contact 100 and moves it resiliently towards the contact 98 to close the switch. The mountings of both contacts are sufficiently resilient to allow the device to complete its action after the contacts have closed. The longitudinal positions of the contact and thus the separation of the blocks 18 and 60 when the contacts close, can be adjusted by loosening the screw 95, rotating the disc 96 and hence the switch assembly to move the contacts in the slot 92, and tightening the screw 95 to hold the disc in this new position.

In an alternative embodiment (not shown), a sub-microswitch is mounted on the edge of the block 18 with its roller in the path of the trigger lever 52 so as to be operated during movement of the lever to operate the syringe.

The metering device is attached to a syringe and used as follows:

Before preparing the device for fitting to the syringe the leaf spring 70 on the head block is moved to one side

5

of the aperture. The syringe, from which the plunger has been partially withdrawn, is then inserted plunger button first through the bore 20 in the block 18 until the radial web 24 on the barrel 12 abuts the tubber O-ring 26. The plunger meanwhile extends upwardly through the bore 62 in the block 60. The collar 28 is threaded over the needle of the syringe and up the barrel 12 until it can be screwed into the bore 20 to clamp the barrel web securely inside the block 18. The rubber O-ring prevents rotation of the barrel web during this clamping.

If the syringe plunger is formed by a stiff wire which can be withdrawn from the syringe barrel but which is liable to damage during the injection, then it is withdrawn upwardly from the barrel and a short protective sleeve (not shown) is threaded onto it. The length of the protective sleeve is such that when the plunger wire abuts the syringe body, the sleeve forms a loose protective sheath around the plunger wire limiting the extent to which the portion of the wire protruding from the barrel can be bent transversely. The protruding wire portion is therefore prevented from being permanently damaged through being bent beyond its elastic limit during forceable discharge of the sample from the syringe.

Some syringes used for injecting very small volumes such as tenths of a microlitre, have plungers formed by wires so thin that they are permanently arranged inside telescoping protective tubes 106 as shown in FIG. 2. Such tubes prevent damage to the wire during injection and therefore, in this case, the radially slotted circular plate 68 which has no sleeve is slid under the plunger button and over the tubes 106. The circular plate is trapped between the plunger button 64 and the flange 66. The resilient leaf spring 70 and pad 76 hold the button firmly in engagement with the plate so that the plunger is firmly held.

To set the volume taken up by the syringe the block 60 is eased away from the block 18 against the force of the Tensator spring until the end of the pin 81 is clear of the disc 46. The trigger arm 52 is then moved to displace the arcuate cut-out 50 from beneath the pin. The block 60 is then allowed to move under the force of the spring towards the block 18 until the end of the pin engages the disc 46. The knurled head 82 of the pin is then rotated until the tip of the plunger, as viewed through the transparent barrel of the syringe, is at the calibration corresponding to the volume of sample to be loaded. The lock nut 84 is then screwed down onto the block 60 to hold the pin firmly in position. The switch assembly is then adjusted so that the contacts close at some predetermined point during the injection operation of the device, preferably at the end of the injection.

To load the syringe the trigger arm 52 is turned to allow the plunger to be pulled into the syringe. The needle is inserted into the sample liquid and the block 60 is pulled away from the block 18 to load the syringe in the customary manner. When the end of the pin is clear of the disc 46 the trigger arm 52 is turned to its former position and the head block is released. The Tensator spring expels from the syringe surplus sample liquid until the end of the pin engages the disc 46. The syringe is now loaded to the volume desired. The socket 102 is connected to a device arranged to provide a signal to the input of a chromatograph recorder, to provide an event mark, when the contacts close, on the recorder trace. Alternatively the socket is connected to an auxiliary device arranged to start the recorder when the contacts close.

The needle of the syringe is now introduced through a rubber septum in the chromatograph into the carrier gas stream. The trigger arm 52 is turned to free the abutment from beneath the pin and so allow the spring to draw the block 60 towards the block 18 to expel the sample. As the Tensator spring offers a constant force, the sample is discharged at a constant rate which is predetermined to ensure a rapid discharge. During dis-

6

charge the movement of the head block is guided by the two slide rods 42 passing through the tubes 40 in the body block. Towards the end of the discharge the contacts 98 and 100 are closed to provide an event mark or start the recorder.

To take the next sample the syringe needle is dipped into the sample liquid and the head block is pulled back until the end of the pin is seen to be clear of the disc 46. This is then rotated into the path of movement of the pin and the block 60 is released to expel surplus liquid from the syringe. When the end of the pin engages the disc 46 the volume of sample contained in the syringe is identical to that of the previous sample. Injection of the sample can then take place as above described.

It will be appreciated from the above description that the syringe has a high reproducibility of performance as the volume of sample held for each run of a series is determined by the relative positions of the pin 81 and the disc 46 and is independent of the operator. Also, during each injection, the force applied to the plunger is maintained sensibly constant by the Tensator spring so that the physical length of two separately injected samples in the carrier stream is substantially the same and a true comparison can be made between a calibration run and a run using a sample to be analysed. Also by use of said short protective sleeve damage to a wire plunger of a syringe not otherwise protected from excessive bending, is prevented.

I claim:

1. A metering device for use with a syringe in chromatography and comprising:
  - (a) a body member for attachment to the syringe barrel,
  - (b) a head member for attachment to the outer end of the syringe plunger,
  - (c) means mounting the head member on the body member for movement with respect to the body member in opposite directions,
  - (d) constant tension spring means to urge the members towards each other,
  - (e) means for holding the members a predetermined distance apart comprising:
    - (i) a pin on one of said members extending parallel to said directions,
    - (ii) an abutment element movably mounted on the other member and movable between one position in which it lies in the path of said pin to maintain the members a predetermined distance apart and another position in which it is out of the path of said pin to allow said constant tension spring means to move the members together to expel a predetermined amount of fluid from a syringe mounted in the device.
2. The metering device of claim 1 in which said pin is adjustable longitudinally of said one member to vary said predetermined distance.
3. The metering device of claim 1 which includes switch means for connection in an auxiliary electrical circuit and means for operating the switch means in synchronism with the device.
4. The metering device of claim 1 wherein said head member comprises means for gripping a finger button at said outer end of the syringe plunger, said means being adjustable to accommodate plunger buttons of various thicknesses.
5. The metering device of claim 1 which includes means including a tube to receive a syringe plunger to prevent deformation thereof during injection.
6. A metering device for use with a syringe in chromatography and comprising:
  - (a) a body member for attachment to the syringe barrel,
  - (b) a head member for attachment to the outer end of the syringe plunger,

7

- (c) means mounting the head member on the body member for movement with respect to the body member in opposite directions,
- (d) means acting between the members to urge the members towards each other,
- (e) means for holding the members a predetermined distance apart comprising:
  - (i) a pin on one of said members extending parallel to said directions,
  - (ii) an abutment element movably mounted on the other member and movable between one position in which it lies in the path of said pin to maintain the members a predetermined distance apart and another position in which it is out of the path of said pin to allow said means acting between the members to move the members together to expel a predetermined amount of fluid from a syringe mounted in the device,
- (f) the said other member having a face adjacent to said one member substantially perpendicular to said pin and a bore extending co-axially of said pin to receive the latter,
- (g) said abutment element including a plate having a slot therein and lying against said face and being pivoted to said other member about an axis perpendicular to said face, said plate in said one position occluding said bore and in said other position having said slot in register with said bore,
- (h) said abutment element further including a manually operable trigger arm by which it may be moved between said positions.

7. The metering device of claim 6 in which said body member includes a hand grip and said trigger arm is disposed so as to be operable by a finger of a hand gripping the hand grip.

8. A metering device for use with a syringe in chromatography and comprising:

- (a) a body member for attachment to the syringe barrel,
- (b) a head member for attachment to the outer end of the syringe plunger,
- (c) means mounting the head member on the body

8

- member for movement with respect to the body member in opposite directions,
- (d) means acting between the members to urge the members towards each other,
- (e) means for holding the members a predetermined distance apart comprising:
  - (i) a pin on one of said members extending parallel to said directions,
  - (ii) an abutment element movably mounted on the other member and movable between one position in which it lies in the path of said pin to maintain the members a predetermined distance apart and another position in which it is out of the path of said pin to allow said means acting between the members to move the members together to expel a predetermined amount of fluid from a syringe mounted in the device,
- (f) a switch assembly on said body member adapted to be connected to an auxiliary circuit including a fixed contact and a moving contact mounted between said body member and said head member to be engaged by the latter when moving towards said body member so as to be urged into engagement with said fixed contact.

9. The metering device of claim 8 in which said switch assembly is fixed to means adjustably mounted on said body member so that the position of the switch contacts between the members can be adjusted to suit different types of syringe.

References Cited

UNITED STATES PATENTS

3,074,597	1/1963	Felts	222-309	X
3,075,674	1/1963	Hruskoci	222-340	X
3,122,280	2/1964	Goda	222-340	X
3,162,217	11/1964	Poli et al.	222-309	X

ROBERT B. REEVES, Primary Examiner

H. S. LANE, Assistant Examiner

U.S. Cl. X.R.

222-23, 340