

**(12) STANDARD PATENT**  
**(19) AUSTRALIAN PATENT OFFICE**

(11) Application No. **AU 2006301860 B2**

(54) Title  
**Dynamic mixer**

(51) International Patent Classification(s)  
**B01F 13/00** (2006.01)                      **B05C 17/00** (2006.01)  
**B01F 5/06** (2006.01)

(21) Application No: **2006301860**                      (22) Date of Filing: **2006.10.03**

(87) WIPO No: **WO07/041878**

(30) Priority Data

(31) Number                      (32) Date                      (33) Country  
**1619/05**                      **2005.10.07**                      **CH**

(43) Publication Date: **2007.04.19**

(44) Accepted Journal Date: **2010.11.11**

(71) Applicant(s)  
**Sulzer Mixpac AG**

(72) Inventor(s)  
**Keller, Wilhelm A.**

(74) Agent / Attorney  
**Watermark Patent and Trade Marks Attorneys, Level 2 302 Burwood Road, Hawthorn, VIC, 3122**

(56) Related Art  
**WO 2004/080611**  
**EP 1106243**  
**DE 4235736**

(19) World Intellectual Property Organization  
International Bureau



(43) International Publication Date  
19 April 2007 (19.04.2007)

PCT

(10) International Publication Number  
**WO 2007/041878 A1**

- (51) International Patent Classification:  
*B01F 13/00* (2006.01)      *B05C 17/00* (2006.01)  
*B01F 5/06* (2006.01)
- (21) International Application Number:  
PCT/CH2006/000538
- (22) International Filing Date: 3 October 2006 (03.10.2006)
- (25) Filing Language: English
- (26) Publication Language: English
- (30) Priority Data:  
1619/05                      7 October 2005 (07.10.2005)      CH
- (71) Applicant (for all designated States except US): **MIX-PAC SYSTEMS AG** [CH/CH]; Grundstrasse 12, CH-6343 Rotkreuz (CH).
- (72) Inventor; and
- (75) Inventor/Applicant (for US only): **KELLER, Wilhelm, A.** [CH/CH]; Obstgartenweg 9, CH-6402 Merlischachen (CH).
- (74) Agent: **AMMANN PATENT ATTORNEYS LIMITED, BERNE**; Schwarztorstrasse 31, Postfach, CH-3001 Bern (CH).

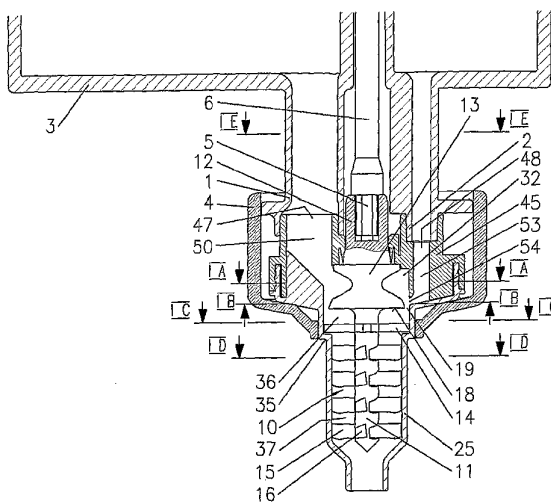
- (81) Designated States (unless otherwise indicated, for every kind of national protection available): AE, AG, AL, AM, AT, AU, AZ, BA, BB, BG, BR, BW, BY, BZ, CA, CH, CN, CO, CR, CU, CZ, DE, DK, DM, DZ, EC, EE, EG, ES, FI, GB, GD, GE, GH, GM, HN, HR, HU, ID, IL, IN, IS, JP, KE, KG, KM, KN, KP, KR, KZ, LA, LC, LK, LR, LS, LT, LU, LV, LY, MA, MD, MG, MK, MN, MW, MX, MY, MZ, NA, NG, NI, NO, NZ, OM, PG, PH, PL, PT, RO, RS, RU, SC, SD, SE, SG, SK, SL, SM, SV, SY, TJ, TM, TN, TR, TT, TZ, UA, UG, US, UZ, VC, VN, ZA, ZM, ZW.
- (84) Designated States (unless otherwise indicated, for every kind of regional protection available): ARIPO (BW, GH, GM, KE, LS, MW, MZ, NA, SD, SL, SZ, TZ, UG, ZM, ZW), Eurasian (AM, AZ, BY, KG, KZ, MD, RU, TJ, TM), European (AT, BE, BG, CH, CY, CZ, DE, DK, EE, ES, FI, FR, GB, GR, HU, IE, IS, IT, LT, LU, LV, MC, NL, PL, PT, RO, SE, SI, SK, TR), OAPI (BF, BJ, CF, CG, CI, CM, GA, GN, GQ, GW, ML, MR, NE, SN, TD, TG).

**Declaration under Rule 4.17:**  
— of inventorship (Rule 4.17(iv))

**Published:**  
— with international search report

For two-letter codes and other abbreviations, refer to the "Guidance Notes on Codes and Abbreviations" appearing at the beginning of each regular issue of the PCT Gazette.

(54) Title: DYNAMIC MIXER



(57) Abstract: The dynamic mixer for mixing components in different volumetric amounts comprises a rotor housing (25) in which a mixing rotor is arranged and which is closed on the inlet side by a cover (45) on which inlets for the components are arranged. The inlet (47) for the first component having the larger volumetric amount leads to an antechamber (32) that communicates with a following mixing chamber (36) by at least one passage (19). The mixing rotor (10) includes a distributor body (13) located in the antechamber for distributing the first component around the axis of rotation of the mixing rotor. The inlet (48) for the second component having the smaller volumetric amount leads to at least one inlet opening (54) located in the area of the passage to the mixing chamber transversally to the axis of rotation. The mixer allows to obtain the correct mixing ratio from the beginning, as well as an optimum and largely bubble-free mixture, and this is achieved at a lower feed pressure, a lower torque, and a lower temperature increase than in conventional mixers.



WO 2007/041878 A1

**DYNAMIC MIXER**

The present invention relates to a dynamic mixer.

5 Particularly when mixing in different volumetric amounts as they are e.g. used for producing detail impression materials the difficulty arises that the two components should be mixed at the correct mixing ratio at the beginning of the mixing process already. If no particular measures are taken,  
10 the component whose volumetric content is smaller, e.g. a catalyst, is absent or not present in a sufficient amount at the beginning of the paste strand discharged from the mixer. The result is an unsatisfactory mixing quality such that e.g. the hardening capability of the casting compound is not  
15 ensured. Another weakness of the currently available mixers is the inclusion of air bubbles, which affects the impression quality.

DE-C-42 35 736 discloses a mixer having consecutive static  
20 and dynamic mixer parts. The static mixer part is positioned before the dynamic one. The dynamic mixer part comprises a mixing cone rotor.

WO-A 2004/080611 describes a dynamic mixer for mixing and  
25 dispensing a plurality of components from a bulk storage device. The mixer has a housing with a rotatable stator therein. The housing further having feeder channels that are configured to have a predetermined cross-section such that a predetermined amount of each component is caused to flow  
30 therethrough. The stator comprises a base and an elongate portion where the base portion comprises paddle and sweeping mix elements, and the elongate portion comprises longitudinal protrusions in axial direction of the mixer. The elongate portion of the housing comprises a plurality of  
35 molded helix threads which together with the protrusions of

the stator further mix the components. The components flow from the feeder channels directly to the stator base portion where they are premixed by the mix elements of the stator base portion. The premixed components are forced to flow  
5 around the stator base portion into the stator receiving portion, i.e. the gap between the longitudinal housing and the stator elongate portion.

EP-A-1 106 243 discloses a dynamic mixer in that for  
10 premixing the components, the mixing rotor comprises a rotor disk near the inlets whose surface facing the inlet side comprises carriers for carrying along the components to be mixed and is provided with gaps arranged in an annular shape at the circumference of the rotor disk and serving for the  
15 passage of the premixed components to the back side of the rotor disk and to the rotor hub provided with mixing elements.

DE-A-100 43 489 discloses a dynamic mixer having a mixing  
20 element with mixing wings. A first mixing wing has inner and outer recesses and a second mixing wing has only outer recesses. Additionally, the mixer has third mixing wings. The axially free recesses of the first and second wings are such that recesses of one wing are covered by the non-free part  
25 of the other wing.

EP-A2-1 402 940 discloses a dynamic mixer having a detour channel in order to retard the entrance of the component having the larger volumetric amount into the mixing chamber.  
30 This measure has the disadvantage that a high pressure is required for delivering that component to the mixing chamber through the detour channel, particularly if it is highly viscous.

On the background of this prior art, a desired object of the present invention is to provide a dynamic mixer ensuring, in a simple manner and without additional pressure losses, that both components are mixed at the correct ratio without  
5 suppressing one of the components, and that air inclusions are avoided.

With the aforementioned in mind, an aspect of the present invention provides a dynamic mixer, including a rotor  
10 housing in which a mixing rotor including a rotor hub is arranged and which is closed on the inlet side by a cover on which inlets for the components are arranged, the inlets for the components lead to an antechamber that communicates with a following mixing chamber by at least one passage, and the  
15 mixing rotor includes a distributor body located in the antechamber for distributing the components around the axis of rotation of the mixing rotor wherein the distributor body includes a longitudinal cross section that is curved toward the rotor hub, and the mixing rotor further includes a disk  
20 portion having at least one passage aperture, the disk portion is arranged after the antechamber as seen in the flow direction of the components, and the mixing rotor is provided with mixing blades located in a post-mixing chamber after the disk portion.

25 A further aspect of this present invention provides embodiments of a dispensing assembly including a double cartridge or a dispensing appliance, having a dynamic mixer according to an embodiment herein described, the double  
30 cartridge or the dispensing appliance having outlets and the dynamic mixer inlets whose diameters are different, wherein the larger outlet is slidable over the larger inlet and the smaller outlet insertable in the smaller inlet.

A still further aspect of the present invention provides a dispensing assembly including a double cartridge or a dispensing appliance, having a dynamic mixer according to an embodiment herein described, wherein the rotor housing cover  
5 of the dynamic mixer and the cartridge the dispensing appliance include coding means in order to allow the attachment of the mixer in only one particular orientation.

The invention will be explained in more detail hereinafter  
10 with reference to drawings of exemplary embodiments.

Figure 1 shows a side elevation and partial section of a first exemplary embodiment of a mixer according to the invention that is secured to a cartridge  
15 by means of a bayonet ring,

Figure 1A shows a section according to line 1A-1A in Figure 1, without the bayonet ring,

20 Figure 1B shows a section according to lline 1B-1B in Figure 1, without the bayonet ring,

Figure 1C shows a section according to lline 1C-1C in Figure 1, without the bayonet ring,

25 Figure 1D shows a section according to lline 1D-1D in Figure 1, without the bayonet ring,

30 Figure 1E shows a section according to lline 1E-1E in Figure 1, without the bayonet ring,

Figure 2 shows a perspective view of the mixing rotor of Figure 1,

2006301860 11 Oct 2010

- 2A -

Figure 2A shows a section of mixing blade 15 according to line 1A-1A in Figure 1D,

- 3 -

- Figure 2B shows a section of mixing blade 16 according to line IB-IB in Figure 1D,
- 5 Figure 3 shows a lateral view and partial section of the mixing rotor of Fig. 2;
- Figure 4 shows a section according to line IV-IV in Figure 5 of the rotor housing of Figure 1,
- 10 Figure 5 shows the rotor housing of Figure 4 as seen from the inlet side,
- Figure 6 shows a perspective view of the rotor housing of Figure 4,
- 15 Figure 7 shows the cover of the rotor housing of Figure 6 as seen from the outlet side,
- Figure 8 shows a section according to line VIII-VIII in Figure 7,
- 20 Figure 9 shows a perspective view of the rotor housing cover of Figure 7,
- 25 Figure 10 shows a perspective view of a second exemplary embodiment of a mixing rotor,
- Figure 11 shows a lateral view and partial section of the mixing rotor of Fig. 10,
- 30 Figure 12 shows a lateral view and partial section of an assembled mixer including the mixing rotor of Figure 11,

- 4 -

Figure 12A shows a section according to line XIIIA-XIIA in Figure 12,

5 Figure 12B shows a section according to line XIIB-XIIB in Figure 12,

Figure 12C shows a section according to line XIIC-XIIC in Figure 12, and

10 Figure 12D shows a section according to line XIID-XIID in Figure 12.

Figure 1 shows the dynamic mixer which is connected to larger outlet 1 and smaller outlet 2 of a double cartridge 3  
15 and secured by means of a bayonet ring 4 and which serves for mixing two components in different volumetric amounts. Hereinafter, the component having the larger volumetric amount will be designated as component A and the component having the smaller volumetric amount as component B.

20

The mixer includes a mixing rotor 10, a rotor housing 20 and rotor housing cover 30. In order to set mixing rotor 10 in rotation, it is coupled on the inlet side to a driver 5 of mixer drive shaft 6.

25

As appears in Figures 2 and 3, the inlet end of mixing rotor 10 comprises a driver hub 12 having an opening for engagement with driver 5.

30 Driver hub 12 has a distributor body 13 located on its inlet side as well as a disk portion 14 and mixing blades 15 and 16, respectively, arranged on following rotor hub 11.

Distributor body 13 has a longitudinal cross section that is  
35 curved toward rotor hub 11. End portion 18 of distributor

- 5 -

body 13 facing disk portion 14 has a circular rim, also shown in Figure 1B. In the assembled condition of the mixer, this rim is located at a distance from the wall of rotor housing 25 such that a gap forming a passage 19 results  
5 between the rim of end portion 18 and the wall of rotor housing 25.

As appears in Figure 1C, disk portion 14 has passageways 20 in the form of slots extending from rotor hub 11 to the edge  
10 of disk portion 14. Different passageways and shapes of the latter may alternatively be provided.

Mixing blades 15, 16 are arranged on rotor hub 11 in multiple planes. The shape of mixing blades 15, 16 is  
15 designed for favorable flow characteristics, i.e. it is chosen such that the components do not detach therefrom during the mixing operation, thereby avoiding the inclusion of unwanted air bubbles. On each level of rotor hub 11, mixing blades 15 having an essentially rhomboid cross-  
20 section, see Figure 2A and mixing blades 16 having an essentially rhomboid cross-section as well (see Figure 2B) are alternately arranged. In Figure 1, the direction of rotation of the mixing rotor is indicated by an arrow, and in Figures 2A and 2B, the direction of rotation is indicated  
25 by DR.

In Figure 1 and in cross-section 1D transversally to the axis of rotation of mixing rotor 10, mixing blade 16 has a rectangular shape while mixing blade 15 is curved in the  
30 shape of a hook on its side 15a turned away from the rotational direction. In an advantageous embodiment, the end portions of all mixing blades are curved and hook-shaped on their sides turned away from the rotational direction.

- 6 -

Mixing rotor 10 is enclosed in a rotor housing 25 closed by a rotor housing cover 45 that is illustrated in Figures 4 to 6. Rotor housing 25 comprises a disk-shaped housing portion 26 receiving rotor housing cover 45 as well as a cylindrical housing portion 27 receiving rotor hub 11 with mixing blades 15 and 16. On bottom surface 28 of disk-shaped housing portion 26, a deflecting body 29 is arranged whose upper side 30 is slanted and forms part of an inlet channel 50 for component A and whose front side 31 forms part of an antechamber 32, cf. Figure 1.

Disk-shaped housing portion 26 further comprises grooves 33 for forming a snap connection with rotor housing cover 45 and a bearing surface 34 for bayonet ring 4. Cylindrical housing portion 27 has a step 35 on which disk portion 14 of mixing rotor 10 is rotatably seated whereby cylindrical housing portion 27 is divided into a mixing chamber 36 and a post-mixing chamber 37. The end of cylindrical housing portion 27 forms mixer outlet 38.

Figures 7 to 9 show rotor housing cover 45 including a rotor bearing 46 for receiving driver hub 12 as well as two inlets 47 and 48 for component A and B, respectively. For a tight seal of driver hub 12, rotor housing cover 45 comprises a sealing lip 49.

Inlet 47 for component A has a larger cross-section than inlet 48 for component B and leads via a channel 50 to antechamber 32 that is partly confined by a wall 51 constituted by a recess 47A formed in the bottom plate of rotor housing cover 45. Smaller inlet 48 leads to the area of passage 19 at the end of antechamber 32 via a step 52 and an essentially cylindrical inlet channel 53 and inlet aperture 54. "In the area of the passage" means that the inlet may be located either in front of or after or opposite

- 7 -

the passage, depending on the volumetric ratio of the components and the design of the distributor body.

The rim of rotor housing cover 45 is provided with grooves 5 33 for forming a snap connection with grooves 33 of rotor housing 25. Rotor housing cover 45 further comprises mechanical coding means, f. ex. in the form of a coding nose 56 directed toward inlets 47 and 48 fitting into a corresponding recess in cartridge 3, thereby allowing the 10 attachment of the mixer to cartridge 3 in a defined orientation only, see sectional view 1E.

In the attached condition of the mixer according to Figure 1, the larger outlet 1 of cartridge 3 is pushed over the 15 larger inlet 47 of the mixer while outlet 2 is pushed into smaller inlet 48 up to step 52, see Figure 8.

Deflecting body 29 shown in Figure 6 is located at the end of inlet channel 50 such that its upper side 30 forms part 20 of inlet channel 50, which leads into antechamber 32 essentially radially with respect to the axis of rotation. Distributor body 13 is arranged in antechamber 32, the latter being confined by the front side 31 of deflecting body 29 and by circular wall 51 of cover 45 shown in Figure 25 7. Inlet aperture 54 of inlet channel 53 leads into antechamber 32 essentially radially.

In the mixing operation within the mixer according to Figure 1, component A is pressed through inlet channel 50 into 30 antechamber 32, guided around the axis of rotation and distributed over the entire cross-section by rotating distributor body 13, and delivered through the passage, i.e. annular gap 19, to mixing chamber 36 in the form of a thin, continuous layer on the entire circumference. Component B is 35 radially delivered through inlet aperture 54 onto the

- 8 -

rotating end portion 18 of distributor body 13 and regularly distributed, as a result of the existing flow and shearing conditions, on the circumference of end portion 18 and premixed with component A.

5

Due to the presence of an antechamber 32, the transport of component A is temporally retarded with respect to component B so that component A reaches mixing chamber 36 a little later than component B rather than before the latter. In  
10 this manner it is ensured that the first portion of the mixture also corresponds to the desired mixing ratio. Driven distributor body 13 allows an air-free filling of antechamber 32 with component A as well as its dynamic distribution which, in contrast to a mixer having a  
15 stationary detour channel, offers the advantage that the flow resistance remains small. Furthermore, the geometry of inlet channel 50, leading from inlet 47 to antechamber 32 by the shortest possible way, also avoids an increase of the flow resistance so that the required delivery pressure in  
20 cartridge 3 and the stresses acting on the dispensing device are altogether low.

When the two premixed components have reached mixing chamber 36, they are essentially directed radially from the  
25 periphery toward the center while a further mixing effect results due to the existing flow and shearing conditions. After its passage through slotted disk portion 14, the mixture fills up post-mixing chamber 37 on the entire cross-section thereof and is subjected to another shearing and  
30 shifting process. The selected shape of mixing blades 15 and 16 avoids an inclusion of air and thereby prevents the formation of bubbles in the mixture. After flowing through the post-mixing chamber, the mixed composition is finally discharged through mixer outlet 38.

35

- 9 -

Figures 10 and 11 show another embodiment of mixing rotor 60 which is a part of the mixer illustrated in Figure 12. Components that are equivalent to the mixer according to Figure 1 are designated by the same reference numerals. The  
5 required feed pressure is further reduced by conveyor blades 17 provided on distributor body 63 in antechamber 32.

As appears in the sectional view of Figure 12A, end portion 68 of distributor body 63 has an oval shape such that a  
10 passage 69 in the form of two rotating gaps results between end portion 68 and the wall of rotor housing 25.

Figure 12B shows the end of channel 53, leading to the edge of end portion 68 of distributor body 63 in antechamber 32  
15 through inlet opening 54.

End portion 68 of distributor body 63 is connected by two lateral ridges 65 to a disk portion 64 having a passage aperture 70 in the form of a slot. cf. Figures 10 and 12C.  
20 Passage aperture 70 extends from the edge of disk portion 64 through its center up to the area near the opposite edge thereof, cf. Figure 12C.

As further appears in Figure 11, at the edge of its passage aperture, disk portion 64 is connected to rotor hub 61 in  
25 such a way that a preponderantly central passage 71 from mixing chamber 36 to post-mixing chamber 37 results.

Mixing blades 15 and 16, arranged in multiple planes on  
30 rotor hub 61, are designed for favorable flow characteristics in order to avoid the inclusion of air bubbles cf. Figures 1D and 12D.

In the mixing operation within the mixer according to Figure  
35 12, component A is pressed through inlet channel 50 into

- 10 -

antechamber 32, guided around the axis of rotation and distributed over the entire cross-section by rotating distributor body 63, and delivered through the rotating passages 69 to mixing chamber 36 in the form of a thin, continuous layer. Component B is introduced into antechamber 32 radially and premixed with component A. On the outlet side of mixing chamber 36, the components are further mixed in combination with passage aperture 70 and central passage 71 and subsequently reach post-mixing chamber 37 where they are post-mixed and finally discharged.

In the mixer according to Figures 1 and 12, inlet opening 54 to antechamber 32 is arranged in the area of passage 19 or 69, respectively. It is conceivable to provide more than one inlet opening 54 in order to be able to introduce component B in multiple locations. It is further conceivable to arrange inlet opening 54 after passage 19 or 69, respectively, for example in such a manner that inlet channel 53 ends in mixing chamber 36.

The optimized design of the mixing operation and the central arrangement of the different mixing elements allow a smaller pressure loss and a reduced mixer drive torque. The reduced friction in the medium reduces energy consumption, thereby resulting in a reduced temperature increase of the mixed material.

The represented arrangements according to Figures 1 and 12 have been described for the case that the volumes of two components are different from each other and that the component having the smaller volumetric amount is therefore delivered to the antechamber in the area of the passage in order to achieve a maximum premixing action. However, the design of the dynamic mixer offers the same advantages when both components have the same volume. In this case, the two

- 11 -

components are symmetrically delivered to the antechamber in the upper area thereof in order to be distributed and premixed therein by the distributor body and to reach the mixing chamber through the passage.

5

In the embodiment having equal volumetric amounts, the inlets and outlets, respectively, are generally identical and the inlets are insertable into the outlets; but other variants are also possible where the outlets are insertable  
10 into the inlets.

Furthermore, more than only one additional, smaller component may be admixed to the larger component. In this case, another inlet as well as another channel having an  
15 inlet opening near the passage are required. The depicted and disclosed characteristic features may be combined with each other as desired.

20

- - - - -

**Claims**

1. Dynamic mixer, including a rotor housing in which a mixing rotor including a rotor hub is arranged and which is closed on the inlet side by a cover on which inlets for the components are arranged, the inlets for the components lead to an antechamber that communicates with a following mixing chamber by at least one passage, and the mixing rotor includes a distributor body located in the antechamber for distributing the components around the axis of rotation of the mixing rotor, wherein the distributor body includes a longitudinal cross section that is curved toward the rotor hub, and the mixing rotor further includes a disk portion having at least one passage aperture, the disk portion is arranged after the antechamber as seen in the flow direction of the components, and the mixing rotor is provided with mixing blades located in a post-mixing chamber after the disk portion.
2. Dynamic mixer according to claim 1 for mixing components in different volumetric amounts, wherein the inlet for the first component (A) includes the larger volumetric amount ends in the upper area of the antechamber the inlet for a second component (B) having a smaller volumetric amount ends in at least one inlet opening located in the area of the passage to the mixing chamber, and the distributor body for distributing the two components is arranged around the axis of rotation of the mixing rotor.
3. Dynamic mixer according to claim 1 for mixing components in equal volumetric amounts, wherein both inlets for the components end in the upper area of the antechamber, and the distributor body for distributing the two components is arranged around the axis of rotation of the mixing rotor.

4. Dynamic mixer according to any one of the preceding claims, where the passage is formed by a gap or multiple gaps between the circumference of the distributor body and the wall of the rotor housing and/or of the rotor housing cover.
5. Dynamic mixer according to any one of the preceding claims, wherein the inlet opening for the second component is arranged such that the latter is delivered essentially transversally to the axis of rotation of the mixing rotor.
6. Dynamic mixer according to any one of the preceding claims, wherein the mixing chamber includes a wall of the rotor housing, of the outlet side of the distributor body and of the outlet side of the disk portion, and wherein the passage aperture(s) is (are) designed such that the components, while flowing through the mixing chamber, are deflected toward the axis of rotation.
7. Dynamic mixer according to claim 6, wherein the rotor housing has a constricting step that serves as a support for the disk portion and which seals the mixing chamber against a following post-mixing chamber at its periphery.
8. Dynamic mixer according to any one of the preceding claims, wherein the distributor body is provided with conveyor blades arranged thereon.
9. Dynamic mixer according to claim 8, wherein the mixing blades have a substantially rhomboid cross-section for favorable flow characteristics, two opposite mixing blades per plane or all mixing blades having a drop- or hook-shaped end on their sides turned away from the direction of rotation.

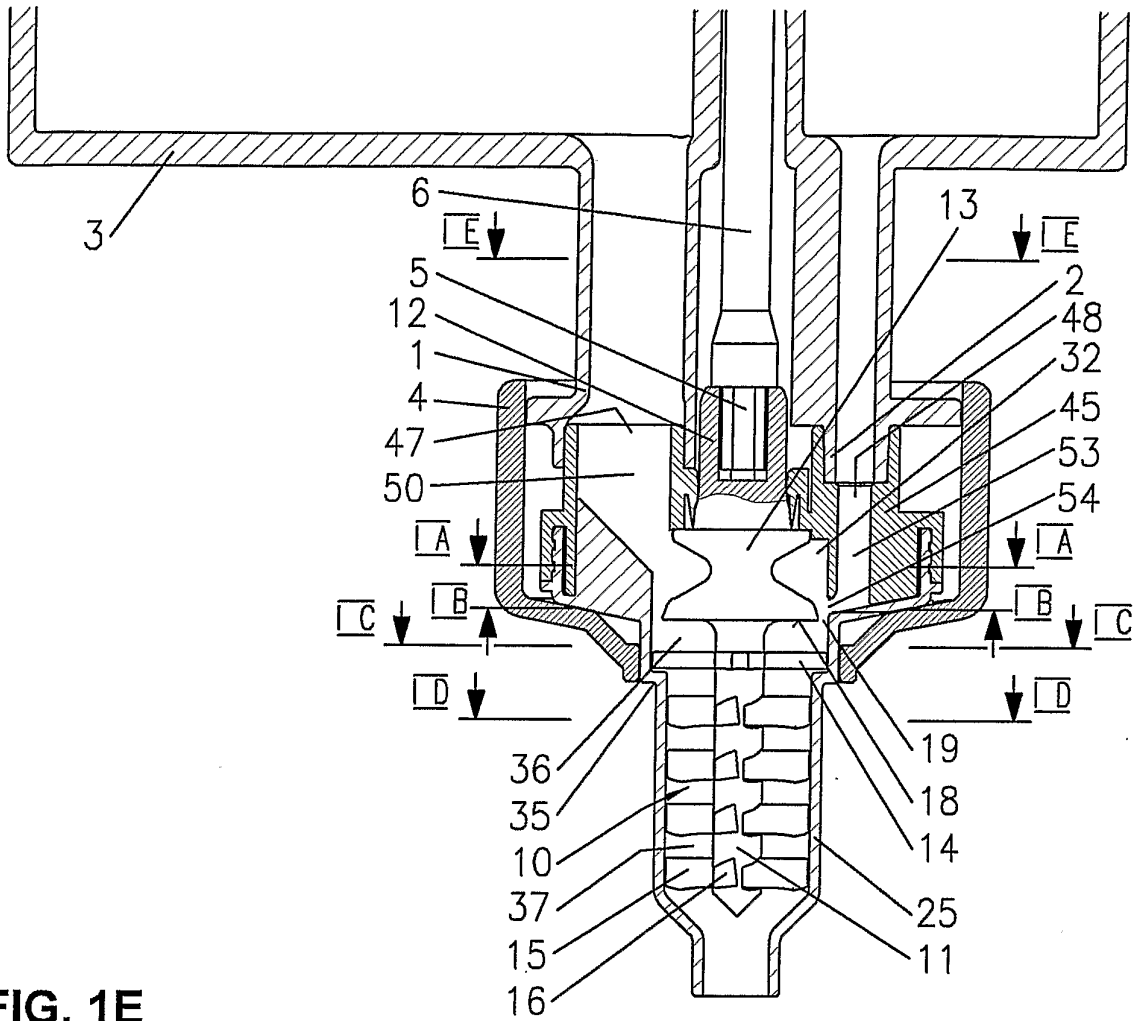
10. Dispensing assembly including a double cartridge or a dispensing appliance, having a dynamic mixer according to any one of claims 1 to 9, the double cartridge or the dispensing appliance having outlets and the dynamic mixer  
5 inlets whose diameters are different, wherein the larger outlet is slidable over the larger inlet and the smaller outlet insertable in the smaller inlet.

11. Dispensing assembly including a double cartridge or a  
10 dispensing appliance, having a dynamic mixer according to any one of claims 1 to 9, wherein the rotor housing cover of the dynamic mixer and the cartridge the dispensing appliance include coding means in order to allow the attachment of the  
15 mixer in only one particular orientation.

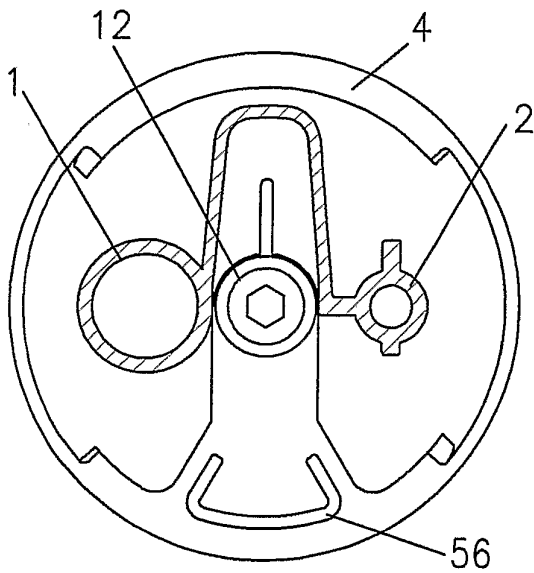
12 Dynamic Mixer substantially as hereinbefore described with reference to figures 1 to 12D.

- - - - -

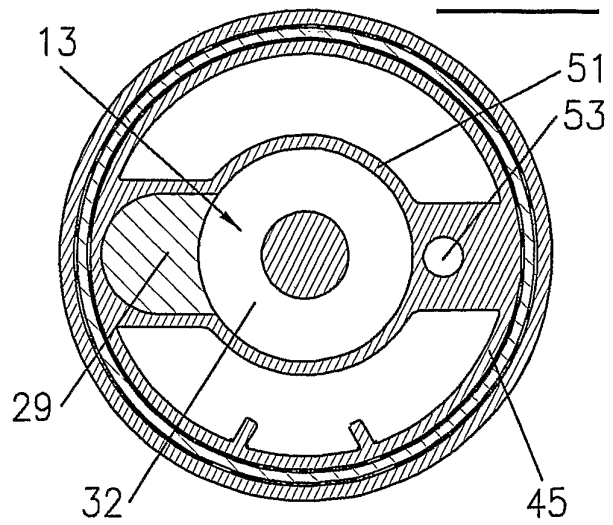
**FIG. 1**



**FIG. 1E**

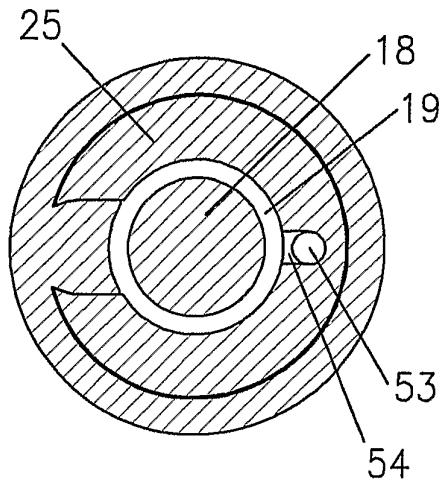


**FIG. 1A**

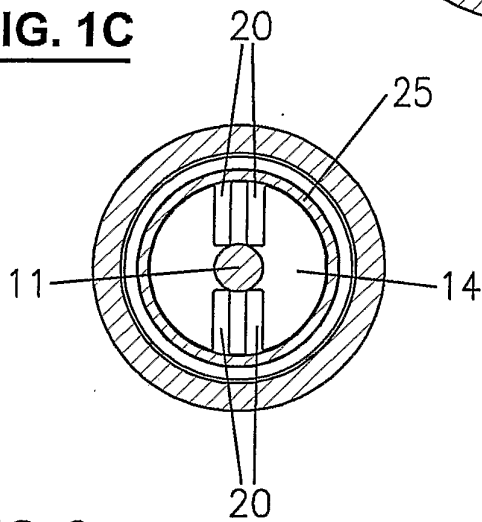


2/6

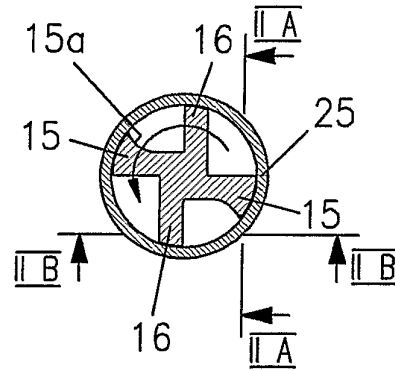
**FIG. 1B**



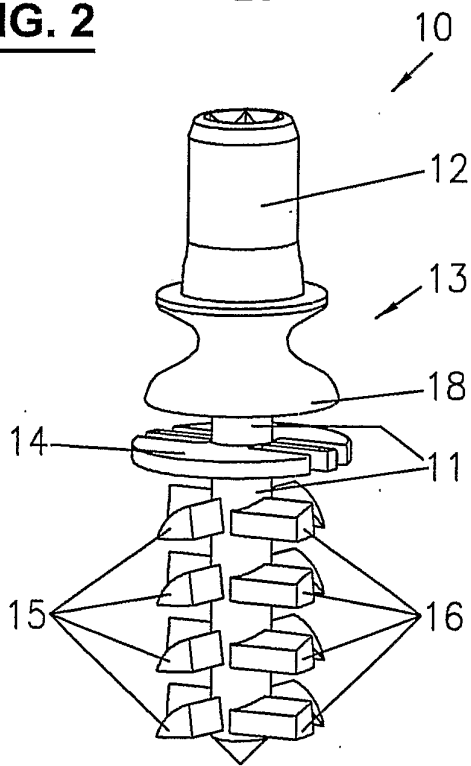
**FIG. 1C**



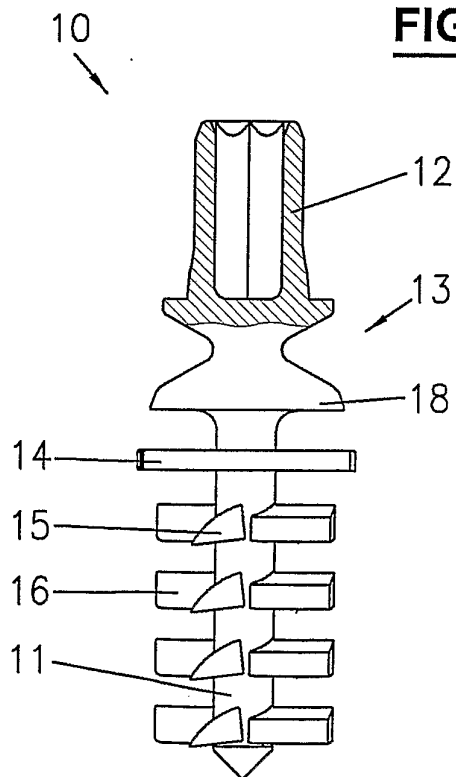
**FIG. 1D**



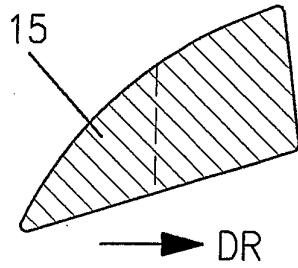
**FIG. 2**



**FIG. 3**

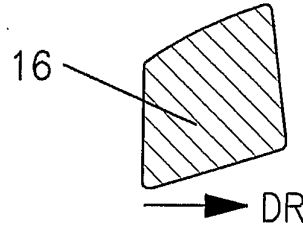


**FIG. 2A**

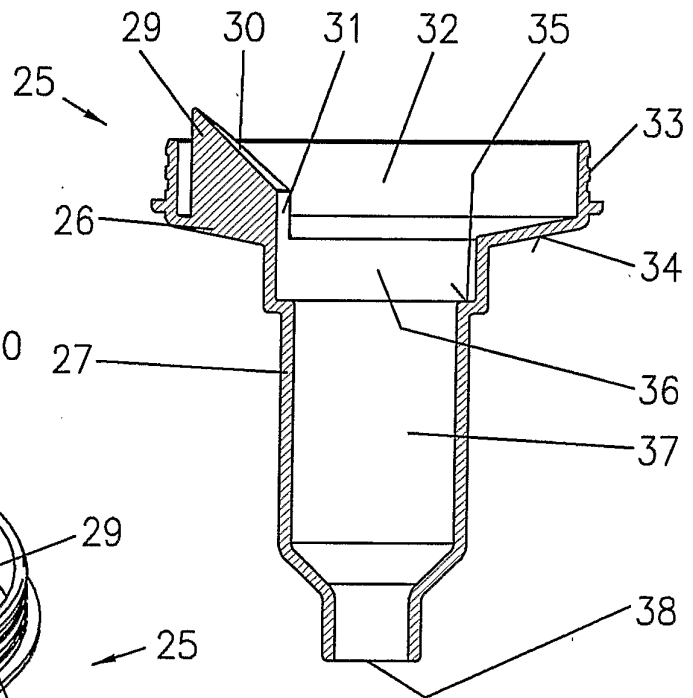


3/6

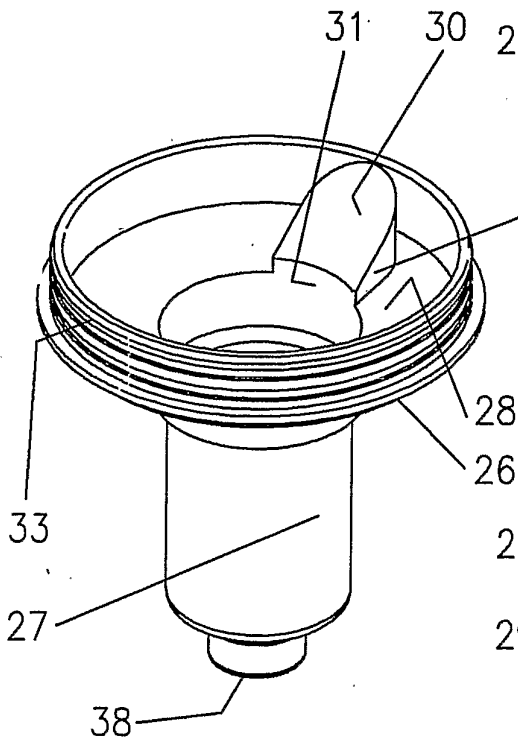
**FIG. 2B**



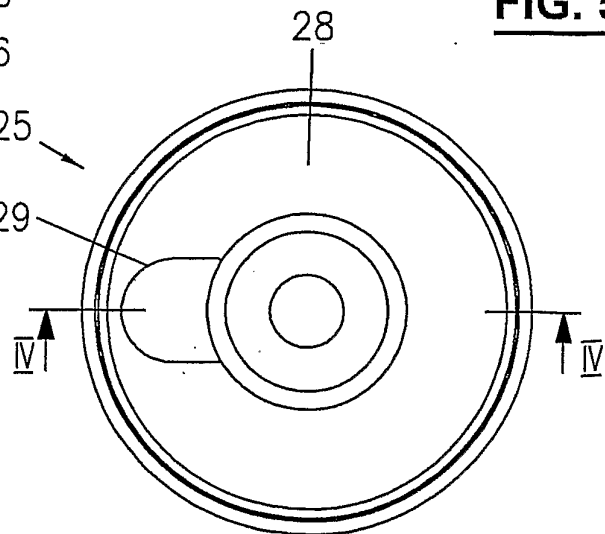
**FIG. 4**



**FIG. 6**

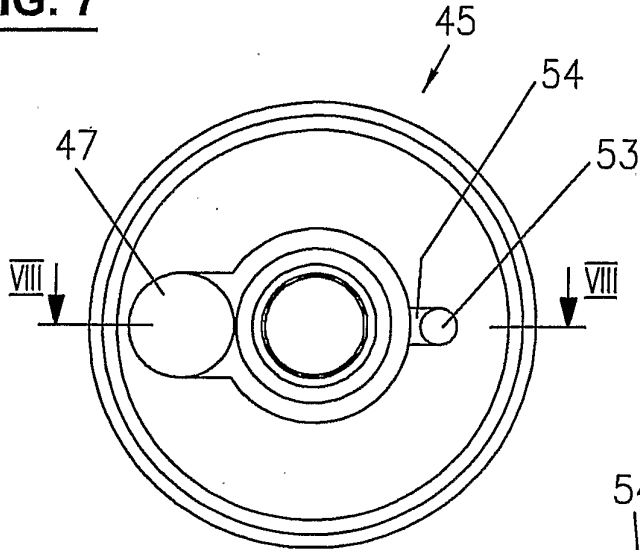


**FIG. 5**

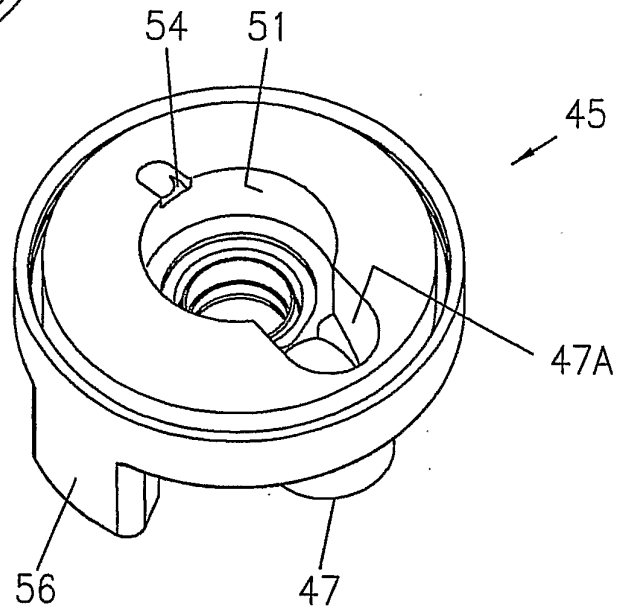


4/6

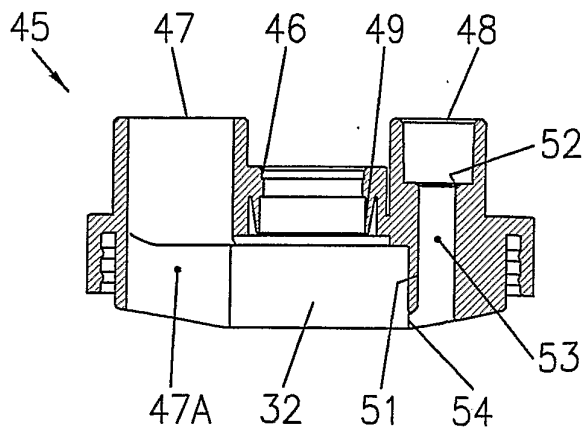
**FIG. 7**



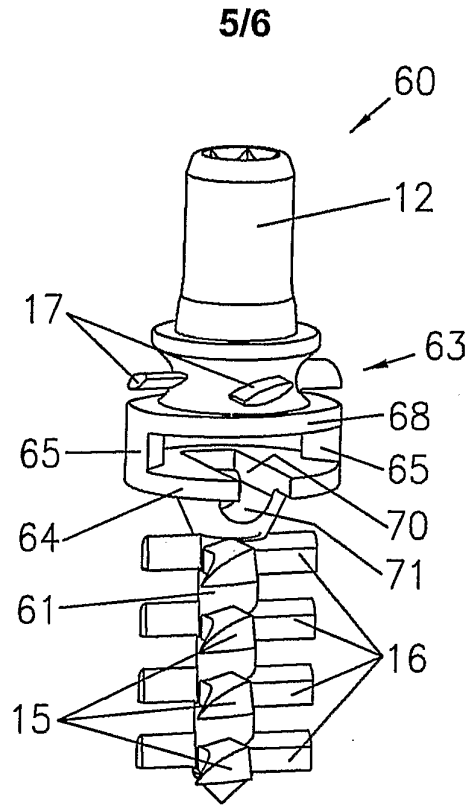
**FIG. 9**



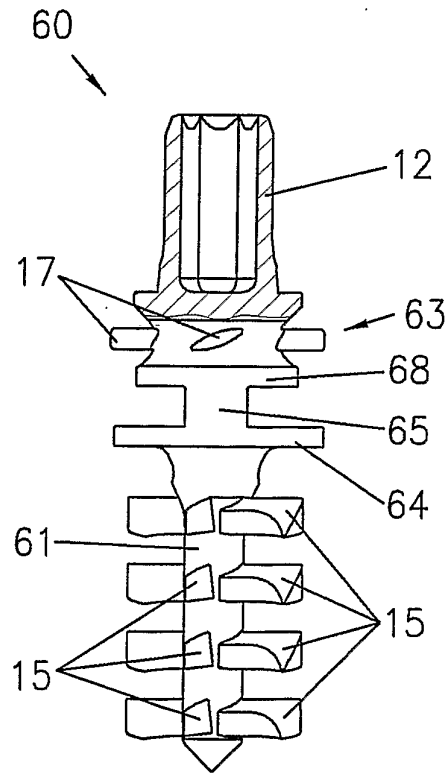
**FIG. 8**



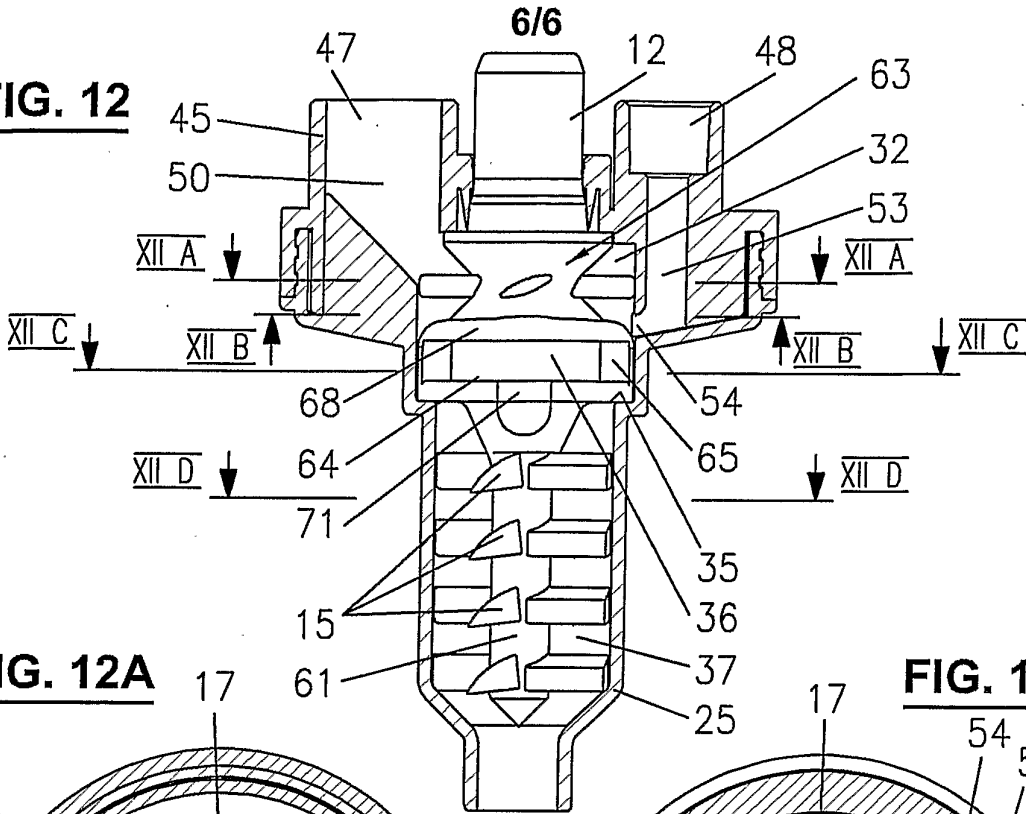
**FIG. 10**



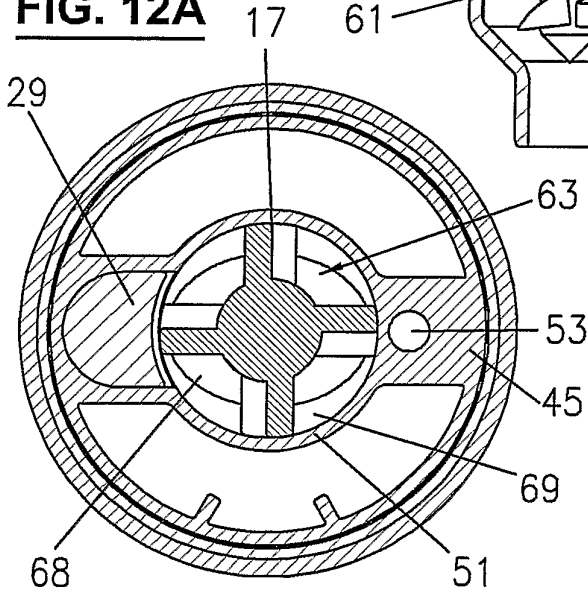
**FIG. 11**



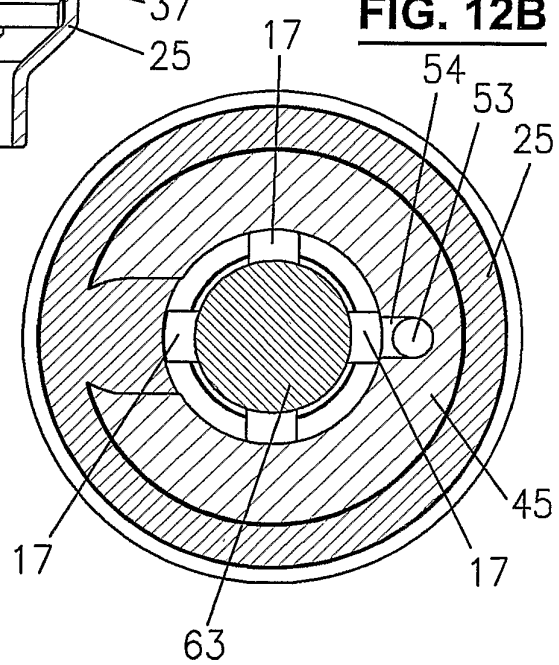
**FIG. 12**



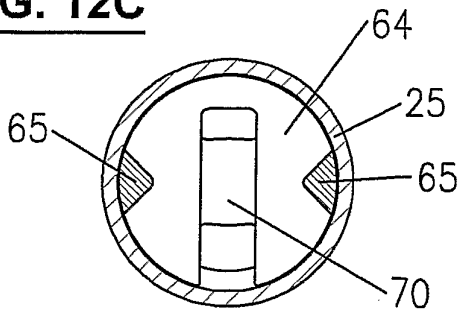
**FIG. 12A**



**FIG. 12B**



**FIG. 12C**



**FIG. 12D**

