



- (51) **International Patent Classification:**
A61F 13/15 (2006.01) *A61F 13/47* (2006.01)
- (21) **International Application Number:**
PCT/IB2014/063088
- (22) **International Filing Date:**
14 July 2014 (14.07.2014)
- (25) **Filing Language:** English
- (26) **Publication Language:** English
- (30) **Priority Data:**
13177874.8 24 July 2013 (24.07.2013) EP
- (71) **Applicant:** GG INNOVATION S.R.L. [—/IT]; Via Del Pesco, 4, I - 59100 Prato (IT).
- (72) **Inventor:** GABRIELLA, Govoni; Via Campani, 32, I-50127 Firenze (IT).
- (74) **Agent:** LUNATI & MAZZONI S.R.L.; Via Carlo Pisacane, 36, Milano, I-20129 MILANO (Mi) (IT).
- (81) **Designated States** (unless otherwise indicated, for every kind of national protection available): AE, AG, AL, AM, AO, AT, AU, AZ, BA, BB, BG, BH, BN, BR, BW, BY, BZ, CA, CH, CL, CN, CO, CR, CU, CZ, DE, DK, DM,

DO, DZ, EC, EE, EG, ES, FI, GB, GD, GE, GH, GM, GT, HN, HR, HU, ID, IL, IN, IR, IS, JP, KE, KG, KN, KP, KR, KZ, LA, LC, LK, LR, LS, LT, LU, LY, MA, MD, ME, MG, MK, MN, MW, MX, MY, MZ, NA, NG, NI, NO, NZ, OM, PA, PE, PG, PH, PL, PT, QA, RO, RS, RU, RW, SA, SC, SD, SE, SG, SK, SL, SM, ST, SV, SY, TH, TJ, TM, TN, TR, TT, TZ, UA, UG, US, UZ, VC, VN, ZA, ZM, ZW.

- (84) **Designated States** (unless otherwise indicated, for every kind of regional protection available): ARIPO (BW, GH, GM, KE, LR, LS, MW, MZ, NA, RW, SD, SL, SZ, TZ, UG, ZM, ZW), Eurasian (AM, AZ, BY, KG, KZ, RU, TJ, TM), European (AL, AT, BE, BG, CH, CY, CZ, DE, DK, EE, ES, FI, FR, GB, GR, HR, HU, IE, IS, IT, LT, LU, LV, MC, MK, MT, NL, NO, PL, PT, RO, RS, SE, SI, SK, SM, TR), OAPI (BF, BJ, CF, CG, CI, CM, GA, GN, GQ, GW, KM, ML, MR, NE, SN, TD, TG).

Published:

- with international search report (Art. 21(3))
- before the expiration of the time limit for amending the claims and to be republished in the event of receipt of amendments (Rule 48.2(h))

(54) **Title:** SANITARY TOWEL

Fig. 1

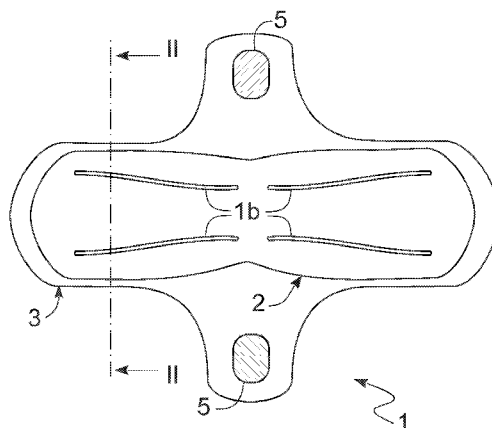

(57) **Abstract:** A sanitary towel (1) is provided, comprising a contact layer (3) with the skin permeable to the passage of fluids; an outer layer (4) impermeable to the passage of fluids; a pad (2) suitable to absorb the fluids, coatings (3a, 4a) of the layers (3, 4) in reciprocal contact; and a high frequency welding bead obtained by exclusively welding of the coatings (3a, 4a) and constraining the contact layer (3) to the outer layer (4) in order to form an inner chamber (1a) for the pad (2).

WO 2015/011602 A1

DESCRIPTION

SANITARY TOWEL

The present invention relates to a sanitary towel of the type as recited in the preamble of the first claim.

- 5 In particular, the invention relates to a sanitary towel, nappy, nursing pad bra liner, or other similar element suitable to be used to absorb liquids produced by the body preventing them from coming into contact with clothes, thereby staining them.

As known, sanitary towels are usually of the disposable type and have a
10 flattened shape so as to be placed between the underwear and skin hindering movement and thereby determining a low level of comfort for the user.

The known sanitary towels are usually composed of a series of layers reciprocally joined by seams. In detail, they may be identified in an upper layer suitable to come into contact with the skin and to permit the transit of liquids, an
15 absorbent layer suitable to absorb the liquids filtering through the upper layer, and a lower layer suitable to come into contact with the garments such as a bra or pair of knickers and prevent the passage of liquids, thereby preventing staining of said garment.

The prior art described above has several significant drawbacks.

- 20 A first significant drawback is the fact that ladies' sanitary towels, nappies or any other sanitary towel are disposable. They cannot therefore be re-utilised and must be thrown away every time.

Such drawback makes for elevated costs for the user, forced to purchase a conspicuous number of sanitary towels.

- 25 Moreover, the purchase of a conspicuous number of sanitary towels has a

significant environmental impact.

In particular, such impact is determined both by the complex and expensive disposal methods and by the fact that to produce a disposable, sanitary towel, large amounts of raw materials are used (wood, plastic, water etc.) as well as particularly expensive and complex chemical processes.

To try to overcome these drawbacks, washable and recyclable sanitary towels have recently been introduced on the market.

Such sanitary towels are made practically entirely from natural, highly biodegradable fibre (usually starch fibre or cotton) permitting washing and thereby re-utilisation of the sanitary towel.

Such sanitary towels, while being a significant improvement compared to disposable sanitary towels, have several significant drawbacks.

A first significant drawback of such washable sanitary towels is the fact that already after the first washes, they rapidly deteriorate and are consequently no longer able to guarantee optimal absorption and, above all, sufficient capacity to retain liquids.

Such drawback is particularly evident at the seams, where on account of the stress suffered by the seams and natural fibres during washing, splits/apertures are formed through which an undesirable exit of the fluid from the sanitary towel occurs.

Another significant drawback, typical especially of sanitary towels made from starch fibre is the fact that such fibre breaks up already during the first washes and thereby rapidly degenerates.

As a result, even these sanitary towels, while being washable and recyclable, since they guarantee optimal absorption only for a limited number of uses, only

partially resolve the problems associated with disposable sanitary towels.

In this situation the technical purpose of the present invention is to devise a sanitary towel able to substantially overcome the drawbacks mentioned above.

Within the sphere of said technical purpose one important aim of the invention
5 is to obtain a sanitary towel which can be re-used and, in particular, which is characterised by a capacity to maintain its absorption and liquid retention properties unaltered for a high number of uses.

Another important aim of the invention is to have a sanitary towel which permits a reduction in the costs of use and disposal.

10 A further aim of the invention is to devise a sanitary towel which is simple and practical to use.

The technical purpose and specified aims are achieved by a sanitary towel as claimed in the appended Claim 1.

Preferred embodiments are described in the dependent claims.

15 The characteristics and advantages of the invention are clearly evident from the following detailed description of a preferred embodiment thereof, with reference to the accompanying drawings, in which:

Fig. 1 shows a sanitary towel according to the invention; and

Fig. 2 shows a method of making the sanitary towel.

20 With reference to said drawings, reference numeral **1** globally denotes the sanitary towel according to the invention.

It is suitable for being placed between a garment and the body so as to absorb urine, milk, blood, faeces or other fluids produced by the body preventing them from coming into contact with garments and thereby staining them. The sanitary
25 towel **1** can therefore be identified as a sanitary towel, (Fig. 1), a nappy,

nursing pad bra liner.

The sanitary towel 1 comprises, mainly, a pad 2 suitable to absorb fluids; a contact layer 3 with the skin permeable to the passage of fluids; and an outer layer 4 suitable to come into contact with a garment and to be joined to the contact layer 3 defining an inner chamber 1a for the pad 2 and, appropriately, one or more flow channels 1b, preferably four, suitable to direct the fluid to the central part of the pad 2.

The contact layer 3 is made from an elastic textile comprising elastam. In particular, it is made from a textile made on weaving machines with a ladder-resist type loom, and composed of an elastic yarn, preferably elastam, and an inelastic yarn, appropriately polyamide microfibre.

Preferably, the contact layer textile 3 is of the antibacterial type obtained using, as the inelastic yarn, a natural fibre with intrinsic anti bacterial properties and/or treating the textile of the layer 3 with an antibacterial finishing process.

The outer layer 4 is of the type impermeable to the passage of fluid so as to prevent the fluid from reaching the garment and thereby staining it.

Preferably, the outer layer 4 is made from polyester.

Advantageously, on both layers 3 and 4 and, in detail, on the mutually facing surfaces of said layers 3 and 4, the sanitary towel 1 comprises coatings 3a and 4a suitable to come into reciprocal contact and to substantially merge forming a high frequency welding bead able to make integral with each other the layers 3 and 4 in order to constrain among them the pad 2. It is highlighted that the welding bead is obtained by high frequency welding and, in detail, it is obtained by melting almost exclusively for high frequency welding of the coatings 3a and 4a.

These coatings 3a and 4a and, therefore, said high frequency welding bead are in polyvinyl or polyurethane or other polymer material. In detail, such coatings 3a and 4a and the high frequency welding bead are in polyurethane and, more specifically in polyurethane and polyamide.

- 5 Appropriately placed between the layers 3 and 4, the sanitary towel 1 has the pad 2.

The pad 2 comprises an acquisition distribution layer (ADL) 2a and an absorbent body 2b suitable to absorb the liquid.

The acquisition and distribution layer 2a is suitable to receive the fluid through
10 the contact layer 3 and to favour its distribution along the surface of the sanitary towel 1, and specifically, of the absorbent body 2b. To such purpose, it comprises a porous thickness suitable to guarantee a rapid acquisition of fluid; and a distribution thickness consisting of a capillary structure suitable to define a plurality of directions of flow of the fluid and thus favour the distribution of the
15 fluid along an extensive surface of the absorbent body 2b.

The absorbent body 2b is suitable to absorb and retain the liquids absorbed by the sanitary towel 1.

It comprises a felted mat of fibres, preferably polyester, comprising deep grooves/channels made along the longitudinal axis of said fibres so as to
20 ensure a high level of absorption by the absorbent body. In particular, the fibres constituting the absorbent body 2b have a plurality of grooves and consequently, a multi-lobal cross-section. More in particular, said fibres are at least pentalobal and more in particular are even octalobal.

Preferably, the absorbent body 2b is made from 4dg[®], marketed by Fiber
25 Innovation Technology.

Additionally, the absorbent body may comprise, in addition to the aforesaid mat, an antibacterial and preferably bacteriostatic fibre and a further mat in polyester fibre with a cross-shaped cross-section.

The antibacterial fibre is suitably made from polymer material with silver particles added and even more specifically from a fibre commercially known as Trevira Bioactive®.

Preferably, the absorbent body 2b comprises multilobal fibre and fibres with a cross-shaped cross-section in percentages substantially comprised between 30% and 50% and the antibacterial fibre in a percentage substantially equal to 20%.

Alternatively, the absorbent body 2b is made from a super absorbent polyester mat.

Additionally, the pad 2 comprises an additional absorbent body, not shown in the drawings, placed between the body 2b and outer layer 4 and suitable to increase the absorption capacity of the sanitary towel 1.

Said additional absorbent body is made in one of the materials described above for the absorbent body 2b.

Lastly, the sanitary towel 1 may have connection means 5, such as velcro, suitable for joining the sanitary towel 1 to a garment (such as a pair of knickers or bra) so as to prevent unwanted relative shifting between the sanitary towel 1 and the garment.

The functioning of a sanitary towel, described above in a structural sense, is as follows.

After connecting the sanitary towel 1 to the garment, positioning the outer layer 4 in contact with said garment, the user wears the garment, placing the sanitary

towel 1 and in particular the layer 3 in contact with the body.

During a discharge of fluid, it initially comes into contact with the layer 3 which, being permeable, allows the fluid to pass through it.

The fluid thus reaches the distribution and acquisition layer 2a which, thanks to
5 its structure, rapidly absorbs the fluid, and contemporarily distributes it along its length.

The fluid lastly reaches the absorbent body 2b which absorbs and retains it, preventing its exit.

When the user decides to replace the sanitary towel 1, she/he detaches it from
10 the garment, washes it in a washing machine and dries it for further use.

The invention comprises a new production method **10** of making sanitary towels
1.

The production method 10 comprises, mainly, an assembly phase **20** in which
the various components of the sanitary towel 1 after being prepared, are laid
15 over each other; and a bonding step 30 in which the layers 3 and 4 are reciprocally joined by high frequency bonding forming an inner chamber 1a for the pad 2 and preferably, flow channels 1b.

In detail, in the assembly step 20 the operator initially cuts the contact 3 and
outer 4 layers, respectively from permeable, elastic and antibacterial sheets of
20 fabric and from polyester sheets and deposits on each of these a coating 3a or 4a.

He then prepares the acquisition and distribution layer 2a and the absorbent
body 2b, cutting through recesses **2c** into them, substantially counter-shaped to
the flow channels 1b.

25 At this point the operator terminates the assembly step 20 placing the pad 2

between the contact layer 3 and the outer layers 4 and, in particular, placing the acquisition and distribution layer 2a between the absorbent body 2b and the contact layer 3.

The bonding step 30 then commences in which the layers 3 and 4 and, precisely, the coatings 3a and 4a are at least partially brought into reciprocal contact and then, connected to each other by high frequency bonding.

First of all, one or more bonding heads 31 reciprocally draw together the portions of the layers 3 and 4 not in contact with the pad 2, that is, the portions of the layers 3 and 4 external to the pad 2 and positioned in correspondence with the recesses 2c.

Then, the heads 31 apply to such portions of the layers 3 and 4 a clamping pressure substantially ranging from 100-150 bar, preferably practically ranging from 110-130 bar and even more preferably substantially equal to 120 bar.

Almost contemporarily, the bonding heads 31 perform the high frequency bonding between such portions of the layers 3 and 4 applying a bonding frequency substantially ranging from 20-30 MHz, in particular substantially ranging from 25-30 MHz and, more in particular, substantially equal to 27 MHz.

Such action of the bonding heads 31 heats and consequently melts almost exclusively the coatings 3a and 4a which thereby form the high frequency welding bead, while the layers 3 and 4 are practically not heated and thus do not substantially vary in their temperature or, as a result, in their structure.

In fact, the high frequency welding, thanks to said bonding heads 31, creates a relative motion between the coating 3a and 4a. Therefore, this welding realizes, between the coating 3a and 4a, a friction that leads to a localized heating of the

coating 3a and 4a and a consequent localized melting of the coating 3a and 4a.

The invention achieves some important advantages.

A first important advantage lies in the fact that the sanitary towel 1, unlike the nappies and sanitary towels of the prior art, is easy to wash and can therefore
5 be re-utilised a number of times.

Such aspect is innovatively achieved thanks to the use of high frequency bonding which by causing heating of the coatings 3a and 4a only, does not alter the characteristics of the sanitary towel 1, and in particular of the layers 3 and
4.

10 In fact, the high frequency welding allows to localize the heat almost exclusively in correspondence of the coatings 3a and 4a which, therefore, melt without heating and, therefore, causing deformation or alteration in the structure of the materials constituting the layers 3 and 4.

Another advantage lies in the fact that the high frequency bonding forms
15 particularly resistant bonds, and above all which do not deteriorate during washing as happens with seams or other solutions used in the sanitary towels of the prior art.

One important advantage therefore lies in the fact that, the sanitary towel 1 does not deteriorate during washing and consequently can be used a large
20 number of times.

Such aspect is further increased by the particular materials used to make the sanitary towel 1 which, unlike starch fibre, does not break up during washing and, consequently, maintains its physical-chemical characteristics unaltered.

In fact, as shown by tests performed by the applicant, the sanitary towel 1 is
25 able to withstand multiple washes in the washing machine at 30°C with spinning

at 600 revs/minutes without detracting from its ability to absorb and retain liquids.

Another advantage is given by the presence of the connection means 5 making it possible to attach or detach the sanitary towel 1 quickly and easily from any
5 garment.

For example, by means of the connection means 5, the operator can very easily attach the sanitary towel 1 to a pair of knickers, use such assembly as a normal sanitary towel and, once used, detach the sanitary towel 1 from the pair of knickers, wash the sanitary towel 1 and lastly reattach it to the knickers forming
10 a new sanitary towel-knicker assembly.

A further advantage is given by the use of an acquisition and distribution layer 2a which, by ensuring particularly rapid absorption, allows the contact layer 3 to dry rapidly and remain in such state.

Such aspect is also achieved thanks to the use of the absorbent body 2b which
15 guarantees, as well as a high absorption capacity, an optimal retention of the fluid absorbed.

Modifications and variations may be made to the invention described herein without departing from the scope of the inventive concept. All the elements as described and claimed herein may be replaced with equivalent elements and
20 the scope of the invention includes all other details, materials, shapes and dimensions.

CLAIMS

1. Sanitary towel (1) comprising a pad (2) suitable to absorb fluids; a contact layer (3) with the skin permeable to the passage of said fluids; an outer layer (4) impermeable to the passage of said fluids; characterised in that said
5 sanitary towel (1) comprises coatings (3a, 4a) of said layers (3, 4) in reciprocal contact; and a high frequency welding bead obtained by almost exclusively welding of said coatings (3a, 4a) and constraining said contact layer (3) to said outer layer (4) in order to form an inner chamber (1a) for said pad (2).

2. Sanitary towel (1) as claimed in the previous claim, in which said
10 coatings (3a, 4a) are in polyurethane.

3. Sanitary towel (1) as claimed in one or more of the previous claims, in which said contact layer (3) is made from an elastic textile.

4. Sanitary towel (1) as claimed in the previous claim, in which said contact layer (3) is made from an elastic textile of the ladder-proof type.

15 5. Sanitary towel (1) as claimed in one or more of the claims 3-4, in which the contact layer (3) is of the antibacterial type.

6. Sanitary towel (1) as claimed in one or more of the previous claims, in which said pad (2) comprises an acquisition and distribution layer (2a).

7. Sanitary towel (1) as claimed in one or more of the previous claims, in
20 which said pad (2) comprises an absorbent body (2b) suitable to absorb the liquid and comprising an octalobal fibre mat.

8. Production method (10) of a sanitary towel (1) comprising a pad (2) suitable to absorb fluids, a contact layer (3) with the skin permeable to the passage of said fluids and an outer layer (4) impermeable to the passage of
25 said fluids; characterised in that said sanitary towel (1) comprises coatings (3a,

4a) of said layers (3, 4) and in that said production method (10) comprises a bonding step (30) in which is realized a high frequency welding bead by almost exclusively welding of said coatings (3a, 4a) so as to reciprocally join the layers (3, 4) forming an inner chamber (1a) for said pad (2).

- 5 9. Production method (10) as claimed in the previous claim, in which said high frequency bonding is performed at a bonding frequency substantially equal to 27 MHz.

10

Fig. 1

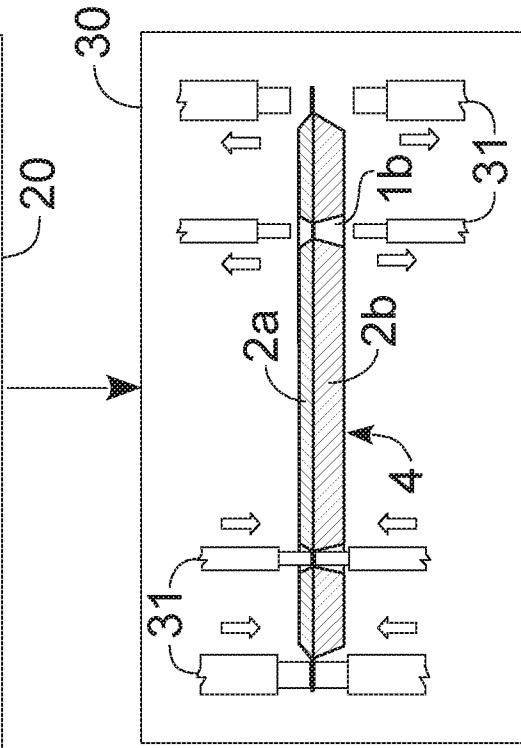
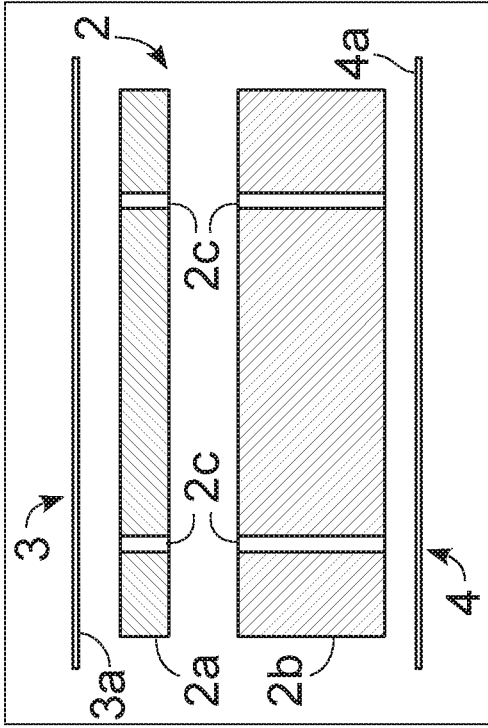
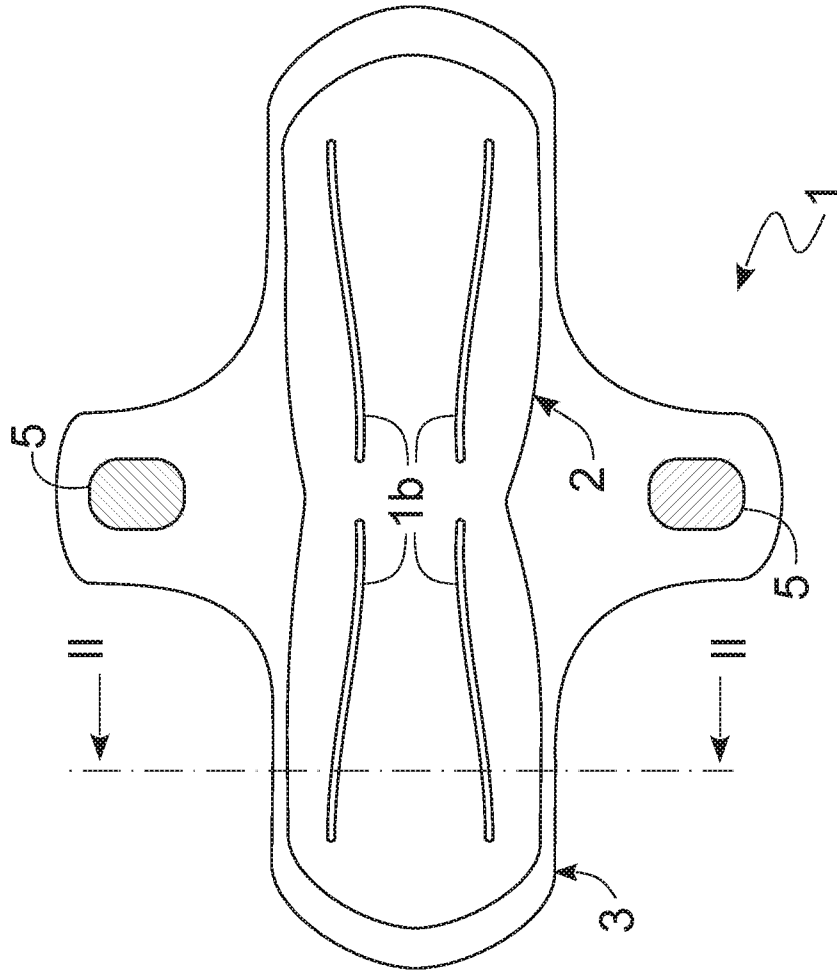

Fig. 2

INTERNATIONAL SEARCH REPORT

International application No

PCT/IB2014/063088

A. CLASSIFICATION OF SUBJECT MATTER

INV. A61F13/15 A61F13/47

ADD.

According to International Patent Classification (IPC) or to both national classification and IPC

B. FIELDS SEARCHED

Minimum documentation searched (classification system followed by classification symbols)

A61F

Documentation searched other than minimum documentation to the extent that such documents are included in the fields searched

Electronic data base consulted during the international search (name of data base and, where practicable, search terms used)

EPO-Internal, WPI Data

C. DOCUMENTS CONSIDERED TO BE RELEVANT

Category*	Citation of document, with indication, where appropriate, of the relevant passages	Relevant to claim No.
A	EP 1 078 617 A2 (JOHNSON & JOHNSON INC [CA]) 28 February 2001 (2001-02-28) paragraph [0010] - paragraph [0024] paragraph [0049] - paragraph [0050]; figures 1-4	1-9
A	EP 1 206 927 A1 (JOHNSON & JOHNSON INC [CA]) 22 May 2002 (2002-05-22) paragraph [0018] - paragraph [0033]; figures 1-3	1-9
A	US 2004/204698 A1 (ZENKER DAVID LOUIS [US] ET AL) 14 October 2004 (2004-10-14) paragraph [0074] - paragraph [0077]	1-9
A	US 6 726 792 B1 (JOHNSON LARRY K [US] ET AL) 27 April 2004 (2004-04-27) column 2, line 3 - line 32 column 6, line 39 - column 8, line 67	1-9

 Further documents are listed in the continuation of Box C. See patent family annex.

* Special categories of cited documents :

"A" document defining the general state of the art which is not considered to be of particular relevance

"E" earlier application or patent but published on or after the international filing date

"L" document which may throw doubts on priority claim(s) or which is cited to establish the publication date of another citation or other special reason (as specified)

"O" document referring to an oral disclosure, use, exhibition or other means

"P" document published prior to the international filing date but later than the priority date claimed

"T" later document published after the international filing date or priority date and not in conflict with the application but cited to understand the principle or theory underlying the invention

"X" document of particular relevance; the claimed invention cannot be considered novel or cannot be considered to involve an inventive step when the document is taken alone

"Y" document of particular relevance; the claimed invention cannot be considered to involve an inventive step when the document is combined with one or more other such documents, such combination being obvious to a person skilled in the art

"&" document member of the same patent family

Date of the actual completion of the international search

20 November 2014

Date of mailing of the international search report

10/12/2014

Name and mailing address of the ISA/

European Patent Office, P.B. 5818 Patentlaan 2
NL - 2280 HV Rijswijk
Tel. (+31-70) 340-2040,
Fax: (+31-70) 340-3016

Authorized officer

Demay, Stéphane

INTERNATIONAL SEARCH REPORT

Information on patent family members

International application No

PCT/IB2014/063088

Patent document cited in search report	Publication date	Patent family member(s)	Publication date	
EP 1078617	A2	28-02-2001	AU 778772 B2	23-12-2004
			AU 5343200 A	22-02-2001
			BR 0004390 A	03-04-2001
			CA 2316499 A1	16-02-2001
			CN 1287827 A	21-03-2001
			CZ 20002983 A3	11-04-2001
			EP 1078617 A2	28-02-2001
			KR 20010021324 A	15-03-2001
			MX PA00008000 A	19-06-2003
			TW 493981 B	11-07-2002

EP 1206927	A1	22-05-2002	AR 031472 A1	24-09-2003
			AU 783434 B2	27-10-2005
			AU 9137301 A	23-05-2002
			BR 0105274 A	25-06-2002
			CA 2363298 A1	16-05-2002
			CN 1363263 A	14-08-2002
			CZ 20014119 A3	17-07-2002
			DE 60116558 T2	13-07-2006
			EP 1206927 A1	22-05-2002
			HK 1046841 A1	04-08-2006
			KR 20020038543 A	23-05-2002
			MX PA01011802 A	20-08-2003
			RU 2278650 C2	27-06-2006
			TW 595468 U	21-06-2004
			US 6585710 B1	01-07-2003
			ZA 200109440 A	15-08-2003

US 2004204698	A1	14-10-2004	US 2004204698 A1	14-10-2004
			WO 2005110312 A1	24-11-2005

US 6726792	B1	27-04-2004	AU 3067799 A	20-09-1999
			CA 2322867 A1	10-09-1999
			DE 69910222 D1	11-09-2003
			DE 69910222 T2	24-06-2004
			EP 1105078 A1	13-06-2001
			JP 2002505159 A	19-02-2002
			US 6042673 A	28-03-2000
			US 6726792 B1	27-04-2004
WO 9944559 A1	10-09-1999			
