

(19) **DANMARK**

(10) **DK/EP 2845279 T3**



(12) **Oversættelse af  
europæisk patentskrift**

Patent- og  
Varemærkestyrelsen

- 
- (51) Int.Cl.: **H 02 G 7/20 (2006.01)**
- (45) Oversættelsen bekendtgjort den: **2018-03-05**
- (80) Dato for Den Europæiske Patentmyndigheds bekendtgørelse om meddelelse af patentet: **2017-12-27**
- (86) Europæisk ansøgning nr.: **13781498.4**
- (86) Europæisk indleveringsdag: **2013-05-14**
- (87) Den europæiske ansøgnings publiceringsdag: **2015-03-11**
- (86) International ansøgning nr.: **US2013040965**
- (87) Internationalt publikationsnr.: **WO2013163660**
- (30) Prioritet: **2012-04-27 US 201261639126 P**
- (84) Designerede stater: **AL AT BE BG CH CY CZ DE DK EE ES FI FR GB GR HR HU IE IS IT LI LT LU LV MC MK MT NL NO PL PT RO RS SE SI SK SM TR**
- (73) Patenthaver: **BOLD Transmission, LLC, 1 Riverside Plaza, Columbus OH 43215, USA**
- (72) Opfinder: **FULK, Meihuan, Zhu, 3663 Hidden Cove Circle, Lewis Center, OH 43035, USA**  
**GUTMAN, Richard, 1407 Beechlake Drive, Columbus, OH 43235, USA**
- (74) Fuldmægtig i Danmark: **Plougmann Vingtoft A/S, Rued Langgaards Vej 8, 2300 København S, Danmark**
- (54) Benævnelse: **Transmissionsledningsdesign med høj kapacitet og høj effektivitet**
- (56) Fremdragne publikationer:  
**EP-A2- 0 089 808**  
**US-A- 4 219 742**  
**US-A- 4 458 102**  
**US-A1- 2008 156 524**  
**US-A1- 2010 064 598**  
**US-A1- 2010 163 298**  
**US-B1- 7 501 574**  
Electric Power Research Institute: "Figure 2.10 Typical pole- and lattice-type structures for 345kV transmission systems", , 1 January 1979 (1979-01-01), XP055282889, Retrieved from the Internet:  
URL:<http://www.myinsulators.com/acw/bookref/poletower/gonentrans-fig2.10.jpg> [retrieved on 2016-06-22]  
Electric Power Research Institute: "Typical 500kV lattice, pole guyed V- and Y-type structures", , 1 January 1979 (1979-01-01), XP055282892, Retrieved from the Internet: URL:<http://www.myinsulators.com/acw/bookref/poletower/gonentrans-fig2.12.jpg> [retrieved on 2016-06-22]



# DESCRIPTION

## CROSS-REFERENCE TO RELATED APPLICATIONS

**[0001]** This application claims the benefit of U.S. provisional patent application Ser. No. 61/639,126 filed on April 27, 2012 for High-Capacity/Efficiency Transmission Line Design, incorporated herein by reference.

## BACKGROUND OF THE INVENTIVE FIELD

**[0002]** The present invention is directed to high-capacity, high-efficiency alternating current (AC) overhead transmission lines. In one embodiment, a power transmission line with a three-phase compact delta configuration is suspended by a single crossarm. The present invention relates to a novel transmission line to maximize load-carrying ability, environmental compatibility, cost effectiveness, and public acceptance.

**[0003]** Public interest in clean, reliable power supplies, combined with renewable generation projects being developed in areas remote from load centers, demands transmission infrastructure capable of delivering efficiently large blocks of power over long distances. In view of the public opposition to overhead transmission in general, and 765 kilovolt (kV) (i.e., the highest transmission voltage class in the U.S.) in particular, electric utilities resort to building conventional 345 kV lines and augmenting such lines with series compensation to achieve the performance characteristics of higher-voltage transmission.

**[0004]** The transmission line design of the preferred embodiment boosts the performance of 345 kV lines beyond their traditional capabilities without relying on costly external devices, such as series capacitors. In the preferred embodiment, low-profile, aesthetic features minimize the environmental impact and structure costs, seeking to improve public acceptance of new transmission projects.

**[0005]** It has been established through engineering analysis and practice that load-carrying ability, or loadability, of a transmission line is limited by one or more of the following factors: (i) thermal rating, (ii) voltage-drop constraint, and (iii) steady-state stability limitation. Thermal rating is an outcome of the conductor and/or terminal equipment selection process, and is most limiting for lines shorter than 50 miles. Longer lines are limited primarily by voltage-drop and/or stability considerations, both of which are directly affected by the length-dependent impedance of the line.

**[0006]** For a given line length, the most effective method of reducing impedance and thereby improving loadability, is to raise the transmission voltage class. However, due to public opposition, multiple lower-voltage lines are built with series compensation to reduce the

impedance and achieve the required loadability objectives.

**[0007]** Series compensation, traditionally, has been used as a near-term remedy to stretch the AC system capability. Also, in some areas, series-compensated lines serve as a substitute for higher-voltage transmission to transport sizable power blocks point-to-point over long distances. These applications invariably are accompanied by concerns such as subsynchronous resonance (SSR) and subsynchronous control interactions (SSCI), known to pose risks to electrical machinery and grid stability.

**[0008]** Other concerns include system protection complexities, maintenance and spare equipment requirements, electrical losses, limited life expectancy relative to that of the line itself, and future grid expandability challenges. Grid expandability is of particular concern when tapping the series-compensated line to serve a new load center or to integrate a new generating source because these developments: (i) can result in overcompensated line segments, and (ii) may be beyond the utility's control.

**[0009]** The new transmission line design, a 345 kV line in the preferred embodiment, minimizes these concerns while inherently offering the requisite capacity and efficiency for both long- and short-distance bulk power deliveries within the electrical grid. US2010/364598 discloses a power transmission tower, which includes a tower body; first through sixth main insulation arms connected by one end thereof to the tower body with an angle with the tower body, respectively, and arranged radially and symmetrically about the tower body in a longitudinal direction; and first through eighth auxiliary insulation arms for selectively connecting the other end of the first through sixth main insulation arms and the tower body so that each of the auxiliary insulation arms constitutes each side of an octagon. Since the insulation arms are octagonally arranged, it is possible to reinforce mechanical strength and enhance electric properties of the tower.

#### **SUMMARY OF THE GENERAL INVENTIVE CONCEPT**

**[0010]** Problems of the prior art are solved by the transmission tower structure defined in independent claim 1. In all embodiments of the invention, a high-capacity, high-efficiency 345 kV overhead transmission line design offers performance advantages relative to typical configurations now in use in the electric utility industry. This design provides a viable alternative to the use of series-compensated 345 kV lines and/or higher-voltage lines for transporting efficiently large power blocks over long distances (e.g., 100 miles); one that is superior in terms of simplicity of design and engineering, construction and operation, grid expandability, life expectancy, and life cycle cost.

**[0011]** The preferred embodiment of the invention represents double-circuit (and single-circuit/double-circuit-capable) lines, characterized by a compact interphase configuration using bundled conductors suspended from structures with a low, aesthetic profile. The new structure preferably is comprised of a single arch-shaped tubular steel crossarm supporting both circuits

symmetrically about a single tubular steel pole shaft. Three phases with two, three, four (or more) bundled conductors each are preferably held together in a "delta" arrangement by means of V-string suspension insulator assemblies and interphase insulators, while maintaining desired phase-to-structure insulator assembly connections. This preferred embodiment of the invention improves the surge impedance loading (SIL) of a transmission line (i.e., a measure of line loadability), reduces its series impedance, lowers both resistive and corona (air ionization) losses, and moderates electromagnetic fields (EMF) and audible noise effects at the ground level -- all achieved in a cost effective manner.

#### **BRIEF DESCRIPTION OF THE DRAWINGS**

**[0012]** The following description of the example embodiments refers to the accompanying figures that form a part thereof. The description provides explanations by way of exemplary embodiments. It is to be understood that other embodiments may be used having mechanical and electrical changes that incorporate the scope of the present invention without departing from the spirit of the invention.

**[0013]** In addition to the features mentioned above, other aspects of the present invention will be readily apparent from the following descriptions of the drawings and exemplary embodiments, wherein like reference numerals across the several views refer to identical or equivalent features, and wherein:

FIG. 1 illustrates the preferred embodiment of the transmission line of the present invention;

FIG. 2 illustrates the preferred embodiment of the transmission line of the present invention (schematic);

FIG. 3 illustrates one typical 345 kV transmission line in use (prior art);

FIG. 4 illustrates another embodiment of the transmission line of the present invention;

FIG. 5 illustrates another embodiment of the transmission line of the present invention;

FIG. 6 illustrates another embodiment of the transmission line of the present invention;

FIG. 7 illustrates another embodiment of the transmission line of the present invention;

FIG. 8 illustrates another embodiment of the transmission line of the present invention;

FIG. 9 illustrates one embodiment of the yoke plate for a 4-conductor bundle;

FIG. 10 illustrates one embodiment of the yoke plate for a 3-conductor bundle;

FIG. 11 illustrates one embodiment of the yoke plate for a 2-conductor bundle.

**DETAILED DESCRIPTION OF EXEMPLARY EMBODIMENT(S)**

**[0014]** Figure 1 shows the preferred embodiment of a 345 kV double-circuit line design of the present invention. It features a streamlined, relatively low-profile structure with phase-conductor bundles arranged into compact "delta" configurations by means of interphase insulators ("delta" means in a substantially triangular shape with internal angles in the range of 30 to 120 degrees). Compact delta configurations have the advantage of improved line surge impedance loading (SIL), lower series impedance, and reduced ground-level EMF effects ("compact" means a relatively closer arrangement than typical transmission line configurations that avoids the need for series compensation or any significant amount of series compensation; "compact" means in the range of 10 to 20 feet between any two phases). SIL, a loading level at which the line attains self-sufficiency in reactive power (i.e., no net reactive power into or out of the line), is a convenient "yardstick" for measuring relative loadabilities of long lines operating at similar, or dissimilar, nominal voltages.

**[0015]** The design of Figure 1 employs up to four (or more) conductors per phase, offering significant gains in thermal capacity and energy efficiency of the line. In situations where four-conductor or larger bundles are deemed unnecessary for thermal reasons, the present invention can be used with three- or two-conductor bundles with associated cost reductions, although some loss of SIL will result. Alternately, the higher cost of larger bundles can be reduced with smaller-diameter conductors, while preserving much of the SIL improvement. Also, the higher cost of larger bundles can be offset by power and energy savings due to greater line efficiency. These changes would represent a refinement of the present invention design described herein.

**[0016]** Considering the sensitivities involved in transmission line placement, the low overall height and aesthetic appearance of the new design are expected to enhance public acceptance of new transmission projects. The new design is efficiently accommodated within a typical right-of-way (ROW), 150 feet wide for 345 kV construction.

**[0017]** Figure 2 shows a schematic of the 345 kV double-circuit design illustrated in Figure 1. It preferably includes a single steel pole shaft (1) supporting an arch-shaped tubular steel crossarm (2), which imparts a streamlined, aesthetic, low-profile appearance. The average overall structure height, at approximately 100 feet, is about 30% lower than that of a traditional 345 kV double-circuit design with the same attachment height of the bottom phase conductor bundle. Each phase contains multiple conductors forming a bundle approximately 16 to 32 inches in diameter. Spacings among the three phases in the example embodiment (approximately 14 feet, 14 feet and 18 feet) are maintained using interphase insulators (7) and (9). These dimensions and bundle/phase arrangements can vary, provided the required interphase clearances are maintained to protect line workers and the public. The crossarm (2) supports preferably two ground/shield wires (12), which are positioned to provide preferred zero-degree shield angle to the outmost phase conductor bundle (62).

**[0018]** Arch-shaped tubular steel crossarm, as shown in Figure 2, is preferred; it provides the insulator assembly attachment points at the desired positions while having a simple and elegant appearance. The crossarm shape can be varied from an arch with the radius of 30-50 feet to a straight arm as long as the attachment points for the insulator assemblies maintain the required phase-to-ground and phase-to-phase clearances.

**[0019]** The preferred configuration of the new 345 kV design employs interphase insulators, which hold phase conductor bundles in a compact delta configuration, and other insulators that attach each of these bundles to the structure/crossarm body to minimize the risk of phase-to-phase faults. The internal angle between the insulator pairs (3) and (4), (6) and (7), (9) and (10) is preferred at 100 degrees but can vary from 60 to 120 degrees. The preferred angle will maintain both sides of V-string insulators in tension under a wind loading of up to 6 psf, which corresponds to wind speed of about 50 mph. Insulators (3), (4), (6) and (10) could be ceramic, glass or polymer, for example.

**[0020]** The interphase insulators (7) and (9) will have the capacity to withstand the design tension, compression, and torsional loads and maintain the phase-to-phase dry-arc distance and leakage distance requirements. The net distance between the grading rings (if required) of the interphase insulator is preferably not less than 9.25 feet. The interphase insulators (7) and (9) will preferably have the same contamination performance as the other insulators used in the V-string. This will result in the actual leakage distance being longer than that of the phase-to-ground insulator by a factor of the square-root of three. Polymer insulators can provide a higher ratio of leakage distance over dry-arc distance to fit more leakage distance into the same overall section length. Silicone rubber polymer insulators are preferable due to higher flashover stress capability compared with ethylene propylene diene monomer (EPDM) rubber polymer insulators and standard ceramic or glass insulators.

**[0021]** Grading rings, if required, are preferably installed on both ends of the polymer insulators. For ceramic or glass insulators, this need is established by electrical testing. The grading rings and their attachments should withstand the electric arcs of a flashover across the insulator and those from a lightning strike. These rings and end fittings should preferably be corona free under dry conditions. The 60 Hz electric field on any part of the polymer portion of the insulator preferably should not exceed 0.42 kVrms/mm for more than a distance of 10 mm measured along the longitudinal axis of the insulator.

**[0022]** As shown in Figure 2 for Circuit No. 1 (70), insulator (3) is suspended from the arch-shaped tubular steel crossarm (2) via a connection plate known as through-vang (16). Insulator (4) is attached to the tubular steel shaft (1) via a through-vang (13). In turn, insulators (3) and (4) suspend yoke plate (5) for a first phase conductor bundle (60). Insulator (6) is suspended from the crossarm (2) via a through-vang (15), and insulator (7) is suspended from yoke plate (5). Insulators (6) and (7) suspend yoke plate (8) for a second phase conductor bundle (62). Insulator (9) is suspended from yoke plate (8), and insulator (10) is attached to the tubular steel shaft (1) via a through-vang (14). Insulators (9) and (10) suspend yoke plate (11) for a third phase conductor bundle (64). The insulators, through-vangs and yoke plates in

Circuit No. 2 (72) are arranged similarly to the corresponding components in Circuit No. 1 (70). A structure of such a configuration may have an approximate height of 100 feet in flat terrain conditions.

**[0023]** For comparison, a typical 345 kV double-circuit pole structure, having circuit one (74) and circuit two (76), in use today is shown in Figure 3. Six conductor crossarms (18) and two shield wire arms (21) are supported by a single steel pole shaft (17). Insulator I-string hardware assembly (19) is suspended from the end of each conductor crossarm (18) and suspends a two-conductor phase bundle (20). The shield wire hardware assembly (22) is attached at the end of each of the two shield wire arms (21). Vertical spacings among the three-phases can vary, but in this structure they are 25.5 feet, 25.5 feet and 51 feet. A structure of such a configuration may have an approximate height of 150 feet in flat terrain conditions.

**[0024]** Table 1 summarizes examples of the physical and electrical characteristics of a typical 345 kV double-circuit line design and three variations of one embodiment of the present invention using two-, three-, and four-conductor bundling arrangements. Of particular interest are the improvements in SIL, impedance, and energy loss properties, which directly influence line loadability and efficiency. These are key considerations in any transmission development built to carry large blocks of power over long distances. Table 1 also provides a comparison between the new and typical line designs' thermal ratings, EMF and audible noise emissions, installed costs, and cost effectiveness expressed in dollars per mile per SIL megawatts. The latter is a more complete measure of the transmission line cost and, when full life cycle costs are considered, it further underscores the advantage of the new design.

Table 1  
Comparison of Typical and Present Invention 345 kV Line Designs

	Typical 345 kV DESIGN	NEW 345 kV DESIGN			
Phase Conductor Bundle	2-954 kCM ACSR Cardinal (18" Spacing)	2-954 kCM ACSR Cardinal (18" Spacing)	3-795 kCM ACSR Drake (30" Bundle Dia.)	4-795 kCM ACSR Drake (30" Bundle Dia.)	
Phase Spacing (Feet) (Phases 1-2/ 2-3/ 3-1)	Actual 25.5 / 25.5 / 51.0	Planned 14.0 / 14.0 / 18.0	Planned 14.0 / 14.0 / 18.0	Planned 14.0 / 14.0 / 18.0	
Structure Height (Feet)	145.5	99 -32%	99 -32%	99 -32%	
<b>EACH CIRCUIT:</b>					
Resistance ( $\Omega$ /100 Miles)	5.01	4.96 -1.0%	3.93 -22%	2.96 -41%	
Surge Impedance ( $\Omega$ )	284	243 -14%	194 -32%	178 -37%	
Surge Impedance Loading (MW)	420	490 +17%	610 +45%	670 +60%	
Thermal Rating (A) <sup>(1)</sup>	2,246	2,246 0%	3,075 +37%	4,100 +83%	
<b>BOTH CIRCUITS COMBINED:</b>					
Resistive Loss (MW/100 Miles) <sup>(2)</sup>	84	83 -1.2%	66 -21%	50 -41%	
Corona Loss (MW/100 Miles) <sup>(3)</sup>	1.0	2.3 +130%	1.6 +60%	0.8 -20%	
Audible Noise @ ROW Edge (dBA) <sup>(4)(5)</sup>	44	53 +20%	44 0%	37 -16%	
Electric Field @ ROW Edge (kV/m) <sup>(4)</sup>	0.5	0.6 +20%	0.8 +60%	0.9 +80%	
Magnetic Field @ ROW Edge (mG) <sup>(4)</sup>	116	54 -53%	54 -53%	54 -53%	
Installed Cost (\$M/100 Miles) <sup>(6)</sup>	151	140 -7%	164 +9%	190 +26%	
Cost Effectiveness (\$/MW-Mile) <sup>(7)</sup>	\$1,798	\$1,429 -21%	\$1,344 -25%	\$1,418 -21%	

## Notes:

- (1) Summer rating for continuous operation in AEP (Western Region)
- (2) Line loss based on 1000 MVA loading in each of two circuits
- (3) Yearly average corona loss (rain 20%, snow 2%, fair 78% of time)
- (4) Results are shown for "superbundle" phase arrangement (Phases 1-2-3; 1-2-3, top-to-bottom); other arrangements are possible. Right-of-way (ROW) width is 150 feet
- (5) Mean value of audible noise in rain at sea level
- (6) Estimated line cost based on NESC Heavy loading zone Grade B design criteria
- (7) Cost effectiveness based on SIL MW capability (two circuits)

**[0025]** As demonstrated, SIL improvements and impedance reductions approaching 60% and 40%, respectively, are achievable with one embodiment of the 345 kV design of the present invention using streamlined, low-profile structures and phase-conductor bundles arranged into compact delta configurations. Also, by using three- or four-conductor phase bundles, significant gains are attained in thermal capacity and energy efficiency of the line, both resulting in lower operating temperatures. A secondary benefit of these improvements is to help unload higher-impedance/lower-capacity lines in the transmission system, thus improving the overall system performance.

**[0026]** Other benefits include: (i) reduced ground-level audible noise, which is comparable to that encountered in a library environment, and (ii) low EMF levels corresponding to a fraction of the applicable industry guidelines, even during most demanding operating conditions.

**[0027]** Ground-level electric fields produced by the present invention and typical designs are very weak, although electric fields associated with the former are higher. Both fields, computed at the line ROW edge, are well within the corresponding industry guideline (5 kV/m). Magnetic field, which presently receives more attention in the scientific community and line siting proceedings, is halved for the same line loading conditions in this embodiment. Depending on the application, further reductions in electric and/or magnetic fields are possible by using other phasing arrangements from that assumed in Table 1.

**[0028]** In the preferred embodiment, ACSR (Aluminum Conductor Steel Reinforced) and symmetrical bundles are considered; however, different conductor types and/or asymmetrical bundles can be used in the present invention with varied effects on cost, electrical and mechanical performance of the line.

**[0029]** All three variations of the present invention design as demonstrated in the embodiment related to Table 1 are more cost-effective on a \$/MW-mile basis than the typical design owing to their greater loadabilities. Moreover, in projects that normally would require series compensation, the avoided cost is the cost of installing and maintaining/replacing the compensation equipment (including SSR/SSCI assessment and/or mitigation costs) over the long term, considering the long life expectancy of a transmission line. Such costs, apart from the concerns noted earlier, can be substantial.

**[0030]** The four-conductor option of the 345 kV double-circuit design of the present invention as shown in Figure 2 also compares favorably with a typical 500 kV line design (where the

three-phases are suspended in a horizontal configuration under a tower crossarm). As shown in Table 2, the former, placed on a 150-foot wide ROW, offers a 40% higher SIL than the latter, which is commonly taller and built on a 175-foot ROW. Energy efficiencies and installed costs of the two designs are similar, with the 345 kV design of the present invention being significantly more cost effective due to its higher loadability - an important objective in bulk power transmission development.

**[0031]** It is evident from Table 2 that the design of the present invention cannot be viewed as a substitute for a typical 765 kV transmission line (where the three-phases are suspended in a horizontal configuration under a tower crossarm), but can serve as the next best alternative. Integrating a 765 kV or a 500 kV line with 345 kV transmission would require transformers and other station equipment, the cost of which is not included in this comparison.

Table 2

<b>New 345 kV vs. Higher-Voltage Designs</b>			
	<b>NEW 345 kV DESIGN<sup>(1)</sup></b>	<b>500 kV DESIGN</b>	<b>765 kV DESIGN</b>
Phase Conductor Bundle	4-795 kCM ACSR Drake (30" Bundle Dia.)	3-1113 kCM ACSS Finch (18" Spacing)	6-795 kCM ACSR Tern (30" Bundle Dia.)
Right-of-Way Width (Feet)	150	175	200
Surge Impedance Loading (MW)	1340	960	2380
Resistive Loss (MW/100 Miles) <sup>(2)</sup>	50	47	14
Corona Loss (MW/100 Mile) <sup>(3)</sup>	0.8	1.1	2.4
Installed Cost (\$M/100 Miles) <sup>(4)</sup>	190	192	266
Cost Effectiveness (\$/MW-Mile) <sup>(5)</sup>	\$1,418	\$2,000	\$1,118

Notes: (1) Data provided for both circuits, combined, of new 345 kV design  
 (2) Line loss based on 1000 MVA loading in each 345 kV circuit; 2000 MVA in 500 kV and 765 kV lines  
 (3) Yearly average corona loss (rain 20%, snow 2%, fair 78% of time)  
 (4) Estimated line cost based on NESC Heavy loading zone Grade B design criteria  
 (5) Cost effectiveness based on SIL MW capability

**[0032]** In alternative embodiments, both straight-shaped tubular steel crossarms and latticed steel crossarms can be used in place of the single arch-shaped tubular steel crossarm of the double-circuit design of Figure 2.

**[0033]** Figure 4 shows an alternative structure configuration of the new design utilizing two straight tubular steel crossarms (23) to support the phase conductors and shield wires (12) for a first circuit (78) and second circuit (80). The length of the insulator assembly (24) would be different from the corresponding insulator assembly (6) in Figure 2 to fit this alternative configuration. A structure of such a configuration may have an approximate height of 105 feet in flat terrain conditions.

**[0034]** Figure 5 shows another alternative with two arched lattice steel crossarms (25) in place of the single arch-shaped tubular steel crossarm (2) shown in Figure 2 to support the phase conductors and shield wires (12) for a first circuit (82) and second circuit (84). Attachment plates (26) and (27) on lattice crossarms, and through-vangs (13) and (14) on steel pole shaft (1), provide support for the insulator assemblies. A structure of such a configuration may have an approximate height of 105 feet in flat terrain conditions.

**[0035]** Figure 6 shows still another alternative with lattice-type steel crossarms (28) and tower body (33) to support the phase conductors and shield wires (12) for a first circuit (86) and second circuit (88). In this alternative, attachment plates (29) and (30) on the crossarms, and attachment plates (31) and (32) on the tower body, support the insulator assemblies. This is a cost effective alternative for use with longer spans in mountainous terrain. A structure of such a configuration may have an approximate height of 105 feet in flat terrain conditions.

**[0036]** It is preferred that none of the alternative designs require a change in the physical phase/conductor positions, thus retaining basic electrical properties of the most representative design (refer to Figure 2), including its load-carrying ability and efficiency.

**[0037]** The above alternatives could simplify the structure fabrication process and reduce costs, but would increase the overall height by 5 to 6 feet. Moreover, they may detract from the line's streamlined appearance (and public acceptance), a significant consideration in crafting the new design.

**[0038]** Figure 7 shows a modification of the present invention, where one arch-shaped steel crossarm (56) supports Circuit No. 1 (90) directly above another arch-shaped steel crossarm (57) supporting Circuit No. 2 (92), both on a single tubular pole shaft (55) structure that can be placed within a narrower ROW, less than 150 feet in width. This design can be modified further to include up to two additional circuits, preferably positioned symmetrically from Circuits No. 1 (90) and No. 2 (92), doubling the overall line loadability, within a 150 feet ROW width.

**[0039]** Figure 8 shows yet another modification of the present invention using crossarms (35), braced-post insulator assemblies (36) and (37) similar to those of Lindsey Manufacturing Co., and I-string suspension insulator assemblies (38) to suspend a yoke plate (39) instead of V-string insulator assemblies to keep the phases in a similar delta arrangement with no interphase insulators. Crossarm (35), supports Circuit No. 1 (94) and Circuit No. 2 (96), The spacings among three phases, each with multiple conductors, are increased in this modified design up to approximately 20 feet to maintain I-string blow out clearance under 6 psf winds.

The increased phase spacings would result in some loss of SIL capability. Ground/shield wire assemblies (42) are arranged at the ends of the crossarm (35). In this exemplary embodiment, through-vang plates (43) and (44) are used to connect insulators (38) and post insulator assemblies (37) to the crossarm. In addition, yoke plates (40) and (41) are attached to the pole shaft (34) by braced post insulator assemblies (36) and (37). Each insulator assembly (36) and (37) is connected to the pole shaft (34) by through-vang plates (45), (46), and (47).

**[0040]** Figure 9 illustrates one embodiment of a yoke plate designed for phase bundles with four conductors. Attached to this yoke plate (5) are four suspension clamps (50) holding the conductors of phase bundle (60). The plate preferably has four insulator attachment holes (51), two of which are for the insulators (3) and (4), and the third hole is for the interphase insulator (7). The fourth hole in this plate is not used in phase conductor bundle (60); it provides an alternate attachment location for the interphase insulator in other phases of this line design. Both ends of insulators (3), (4) and (7) are preferably equipped with grading rings (48), (49) and (52).

**[0041]** Yoke plate (5) can be replaced by yoke plate (53) for three-conductor phase bundles (Figure 10), providing support for three suspension clamps (50) that hold conductors of phase conductor bundle (60). This yoke plate also has four insulator attachment holes (51), two of which are for the insulators (3) and (4), and the third hole is for the insulator (7). The fourth hole is not used in phase conductor bundle (60).

**[0042]** Yoke plate (5) also can be replaced by yoke plate (54) for two-conductor phase bundles (Figure 11), providing support for two suspension clamps (50) that hold conductors of phase conductor bundle (60). This yoke plate has three insulator attachment holes (51). Two holes are for the insulators (3) and (4), and the third hole is for the insulator (7).

**[0043]** The 345 kV double-circuit line design of the present invention (Figure 2) provides, in a cost-effective manner, both high capacity and high efficiency for power transmission. In this embodiment, it is comprised of a single arch-shaped tubular steel crossarm supporting two circuits symmetrically about a single tubular pole shaft giving a simple, relatively low profile, aesthetic appearance; six V-string insulator assemblies forming compact delta configurations of phase conductor bundles with up to four (or more) conductors per phase; each phase with at least one insulator connection to the supporting structure, minimizing the risk of faults involving multiple phases; and four interphase insulators, which allow compaction of the line. The 345 kV double-circuit design of Figure 2 (four-conductor phase bundle) provides improved surge impedance loading of the line, which approaches 670 MW per circuit vs. 420 MW for a traditional design. Further, it lowers both resistive and corona losses, and moderates the EMF and audible noise effects of the line.

**[0044]** The six V-string insulator assemblies preferably include eight phase-to-ground insulators and four interphase insulators. These insulators can be ceramic, glass or polymer insulators, for example. The internal angle between both sides of the V-string insulators is preferred at 100 degrees, but can vary in the 60 to 120 degree range.

**[0045]** In the preferred embodiment, the insulator should meet two primary requirements: it must have: (i) an electrical resistivity, and (ii) a dielectric strength sufficiently high for the given application. The secondary requirements relate to the thermal and mechanical properties. In certain situations, tertiary requirements relating to dielectric loss and dielectric constant also must be observed. In the preferred embodiment, the insulator properties should not deteriorate in a given environment and desired lifetime.

**[0046]** The transmission line of the present invention is flexible and can accommodate two-, three-, four-conductor or larger phase bundles. Different conductor types and/or asymmetrical bundles can be used with varied effects on cost, electrical and mechanical performance. Interphase spacings are controlled by the phase-to-phase dry arc distance for the lightning and switching impulse overvoltages between the grading rings, and the leakage distance that is longer than the phase-to-ground insulation by a factor of the square-root of three.

**[0047]** Two ground/shield wires preferably are installed on top of the single arch-shaped crossarm, providing preferred zero-degree shield angle for the outmost phase conductors.

**[0048]** The single arched tubular steel crossarm of the new design can be substituted with two straight tubular steel crossarms or two lattice steel crossarms while requiring no change in the physical phase conductor positions, thus retaining basic electrical properties of the preferred design.

**[0049]** The single arched tubular steel crossarm and single steel pole shaft can be substituted with a lattice steel crossarm and a lattice steel tower body, respectively, keeping the phase conductor arrangement (and line's electrical properties) unchanged.

**[0050]** Circuit No. 1 can be installed directly above Circuit No. 2 on a single structure by using two arch-shaped steel crossarms without affecting the phase arrangements. This modification of the present invention can be placed within a narrower ROW, less than 150 feet wide. The design can be modified further to include up to two additional circuits, preferably positioned symmetrically from Circuits No. 1 and No. 2, doubling the overall line loadability on a 150-foot ROW.

**[0051]** The V-string insulator assemblies can be substituted with braced-post-insulator and I-string suspension-insulator assemblies to keep the phases in a similar delta configuration with no interphase insulators. However, this modification may require increased phase spacings, resulting in some loss of SIL capability.

**[0052]** The new design offers a viable, elegant, cost-effective alternative to the use of series-compensated 345 kV lines and/or higher-voltage lines now required for long-distance bulk power transportation.

## **REFERENCES CITED IN THE DESCRIPTION**

This list of references cited by the applicant is for the reader's convenience only. It does not form part of the European patent document. Even though great care has been taken in compiling the references, errors or omissions cannot be excluded and the EPO disclaims all liability in this regard.

**Patent documents cited in the description**

- US61639126A [0001]
- US2010364598A [0009]

**Patentkrav**

**1.** Transmissionstårnstruktur til at ophænge en luft-elledning, omfattende:

en tårnstruktur omfattende en vertikal mast (1) og en udhængende arm (2) med  
5 en distal ende i forhold til den vertikale mast;

første, anden og tredje faseledersamlinger (60, 62, 64) til at transmittere elektrisk strøm i et elektrisk strømtransmissionssystem, hver ledersamling består af flere ledere anbragt med afstand, og hver ledersamling til at transmittere elektrisk strøm ved en forskellig elektrisk fasevinkel;

10 første, anden og tredje v-streng-isolatorenheder (3, 4, 6, 7, 9, 10) til at ophænge henholdsvis de første, anden og tredje ledersamlinger, således at hver ledersamling hænger under den respektive v-streng-isolatorenhed, hvorfra den er ophængt,

15 hvor den første v-streng-isolatorenhed omfatter et første ben (4) fastgjort på den vertikale mast,

den anden v-streng-isolatorenhed omfatter et første ben (7) fastgjort på den første v-streng-isolatorenhed og et andet ben (6) fastgjort på den udhængende arm, og

20 den tredje v-streng-isolatorenhed omfatter et første ben (10) fastgjort på den vertikale mast og et andet ben (9) fastgjort på den anden v-streng-isolatorenhed;

**kendetegnet ved at:**

den første v-streng-isolatorenhed omfatter et andet ben (3) fastgjort på den udhængende arm; og

25 hvor de ophængte første, anden og tredje ledersamlinger danner en delta-konfiguration med den distale ende af den udhængende arm tættere på den anden ledersamling end de første og tredje ledersamlinger.

- 2.** Transmissionstårnstruktur ifølge krav 1, hvor den første ledersamling (60) er ophængt under spænding på både det første (4) og andet (3) ben i den første v-streng-isolatorenhed; den anden ledersamling (62) er ophængt under spænding på både det første (7) og andet (6) ben i den anden v-streng-isolatorenhed; og  
5 den tredje ledersamling (64) er ophængt under spænding på både det første (10) og andet (9) ben i den tredje v-streng-isolatorenhed.
- 3.** Transmissionstårnstruktur ifølge krav 1, hvor de første (4) og anden (3) ben i den anden v-streng-enhed under spænding bærer mindst en del af vægten af den  
10 tredje ledersamling (64).
- 4.** Transmissionstårnstruktur ifølge krav 1, hvor de første (4) og anden (3) ben i den første v-streng-enhed under spænding bærer mindst en del af vægten af de anden (62) og tredje (64) ledersamlinger.  
15
- 5.** Transmissionstårnstruktur ifølge krav 1, hvor:
- hver af de første (4) og anden (3) ben i den første v-streng-isolatorenhed, det andet ben (6) i den anden v-streng-isolatorenhed og det første ben (10) i den tredje v-streng-isolatorenhed omfatter en fase-til-jord-isolator;  
20 og
- hver af det første ben (7) i den anden v-streng-isolatorenhed og det andet ben (9) i den tredje v-streng-isolatorenhed omfatter en fase-til-fase-isolator.
- 6.** Transmissionstårnstruktur ifølge krav 1, hvor de ophængte første, anden og  
25 tredje ledersamlinger (60, 62, 64) danner en kompakt delta-konfiguration.
- 7.** Transmissionstårnstruktur ifølge krav 6, hvor den kompakte delta-konfiguration omfatter en fase-til-fase-afstand på ca. 10 til 20 fod mellem midten på en hvilken som helst af to ledersamlinger (60, 62, 64), og indvendige vinkler mellem de  
30 første, anden og tredje ledersamlinger (60, 62, 64) på mellem 30-120 grader, og hvor en nominel driftsspænding af ledersamlingerne er 345 kV.

- 8.** Transmissionstårnstruktur ifølge krav 1, hvor de første, anden og tredje v-streng-isolatorenheder bærer hele vægten af de første, anden og tredje ledersamlinger (60, 62, 64), sammen.
- 5 **9.** Transmissionstårnstruktur ifølge krav 1, hvor den tredje ledersamling (64) er ophængt i det væsentlige under den første ledersamling (60).
- 10.** Transmissionstårnstruktur ifølge krav 1, hvor den udhængende arm (2) er en buet udhængende arm.
- 10 **11.** Transmissionstårnstruktur ifølge krav 1, hvor den udhængende arm (2) er lige og hælder nedad.
- 12.** Transmissionstårnstruktur ifølge krav 1, hvor den udhængende arm (2) er en
- 15 udhængende gitterstålarm.
- 13.** Transmissionstårnstruktur ifølge krav 1, hvor tårnstrukturen omfatter en enkelt vertikal mast (1), idet den udhængende arm (2) strækker sig fra den enkelte vertikale mast (1).
- 20 **14.** Transmissionstårnstruktur ifølge krav 1, hvor tårnstrukturen omfatter et gittertårnlegeme, idet den udhængende arm (2) strækker sig fra gittertårnlegemet.
- 25 **15.** Transmissionstårnstruktur ifølge krav 1, hvor højden på tårnstrukturen over jorden er mindre end 100 fod.

# DRAWINGS

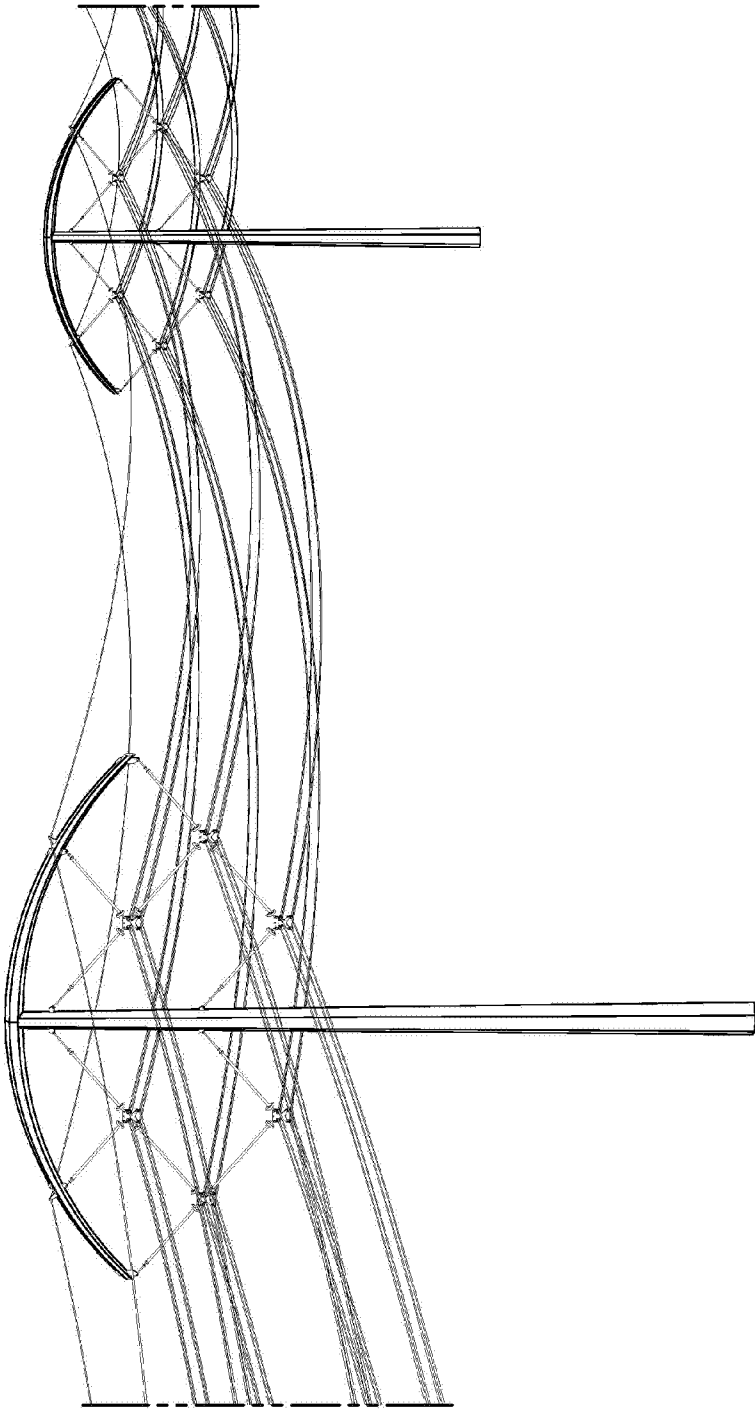

FIG-1

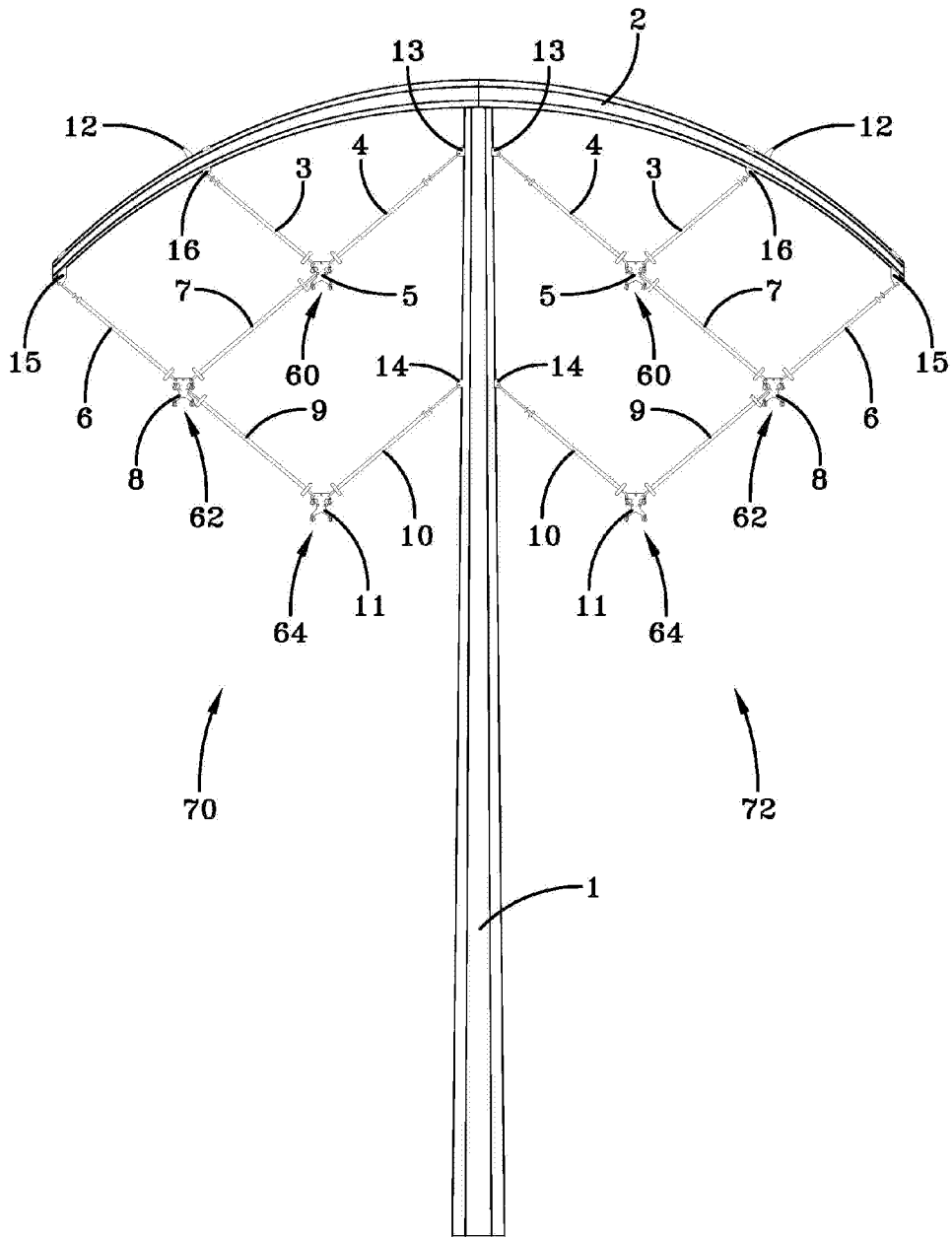
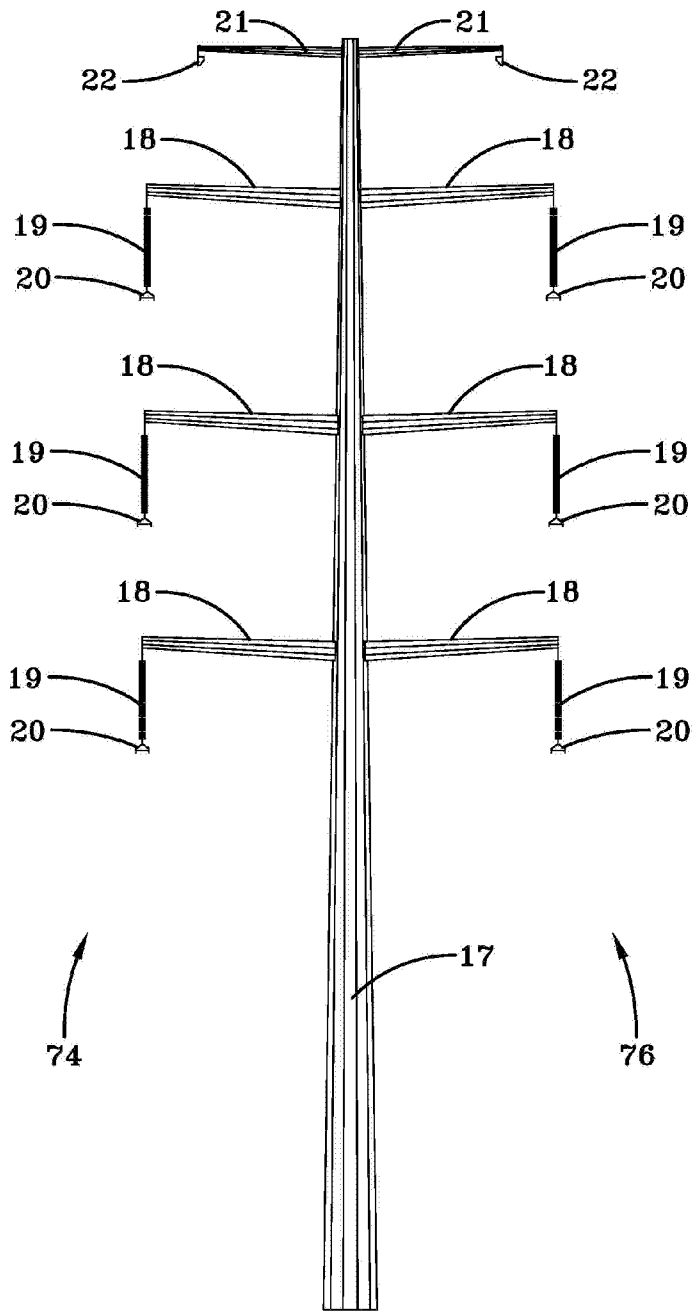

FIG-2



**FIG-3**  
**PRIOR ART**

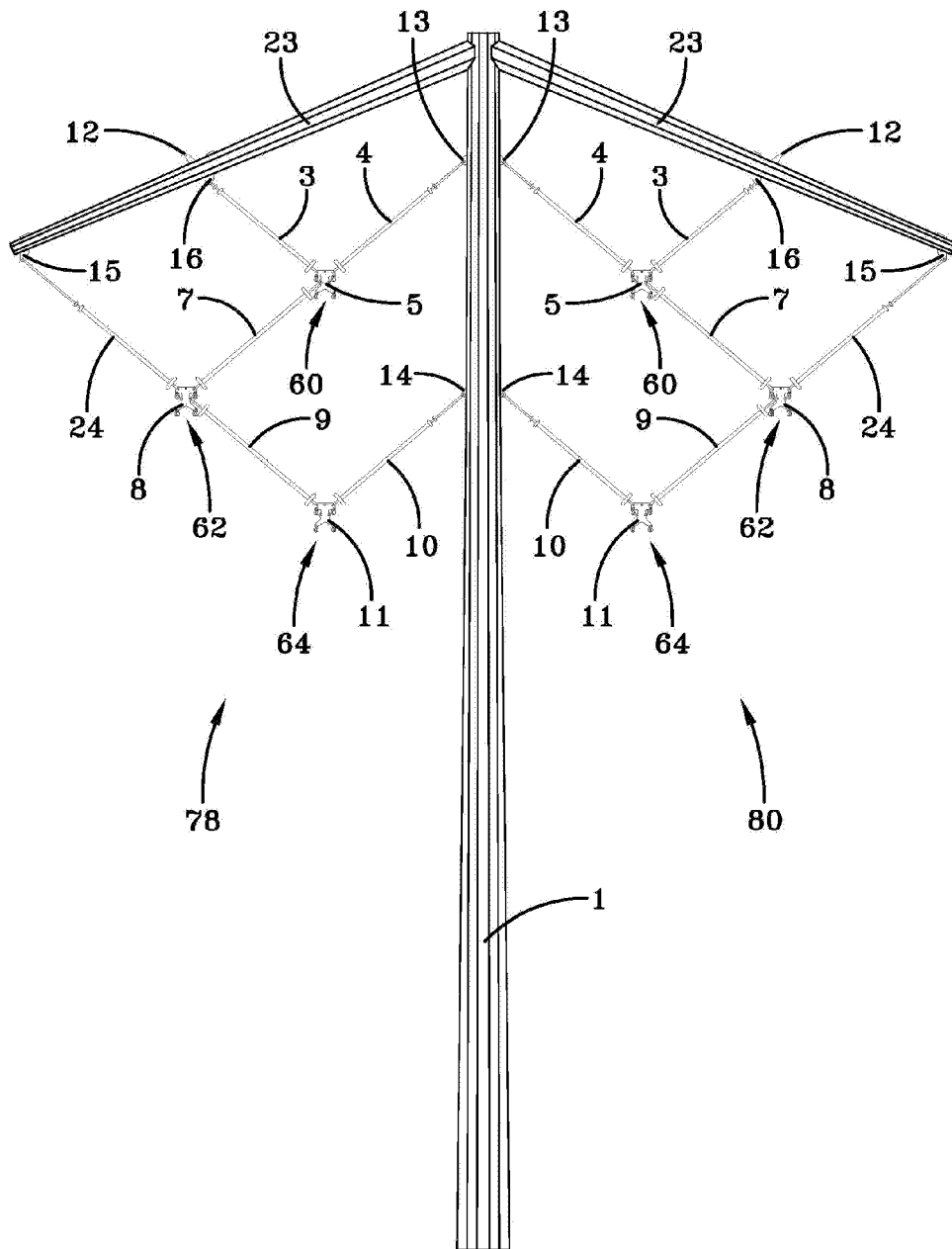

FIG-4

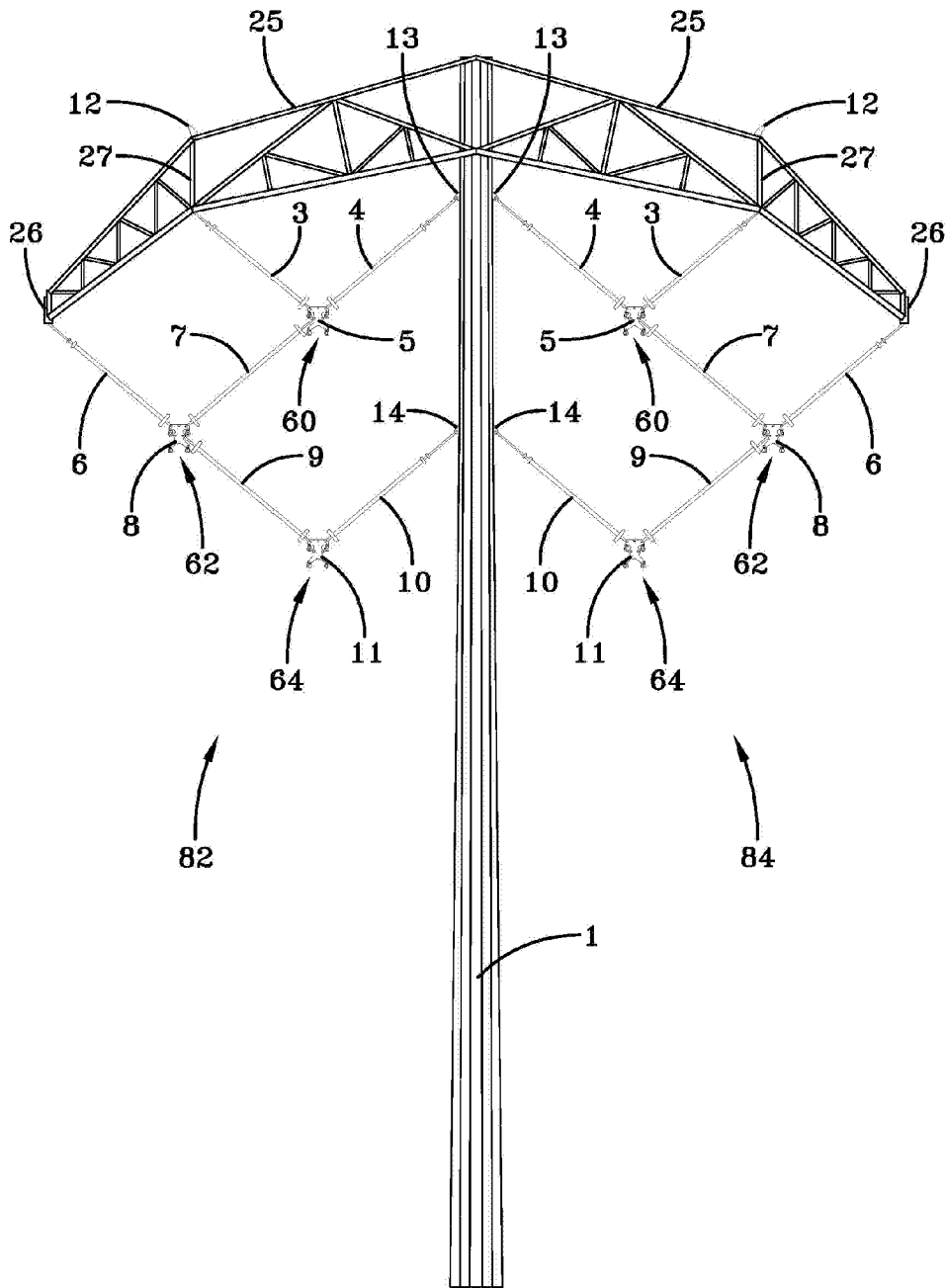

FIG-5

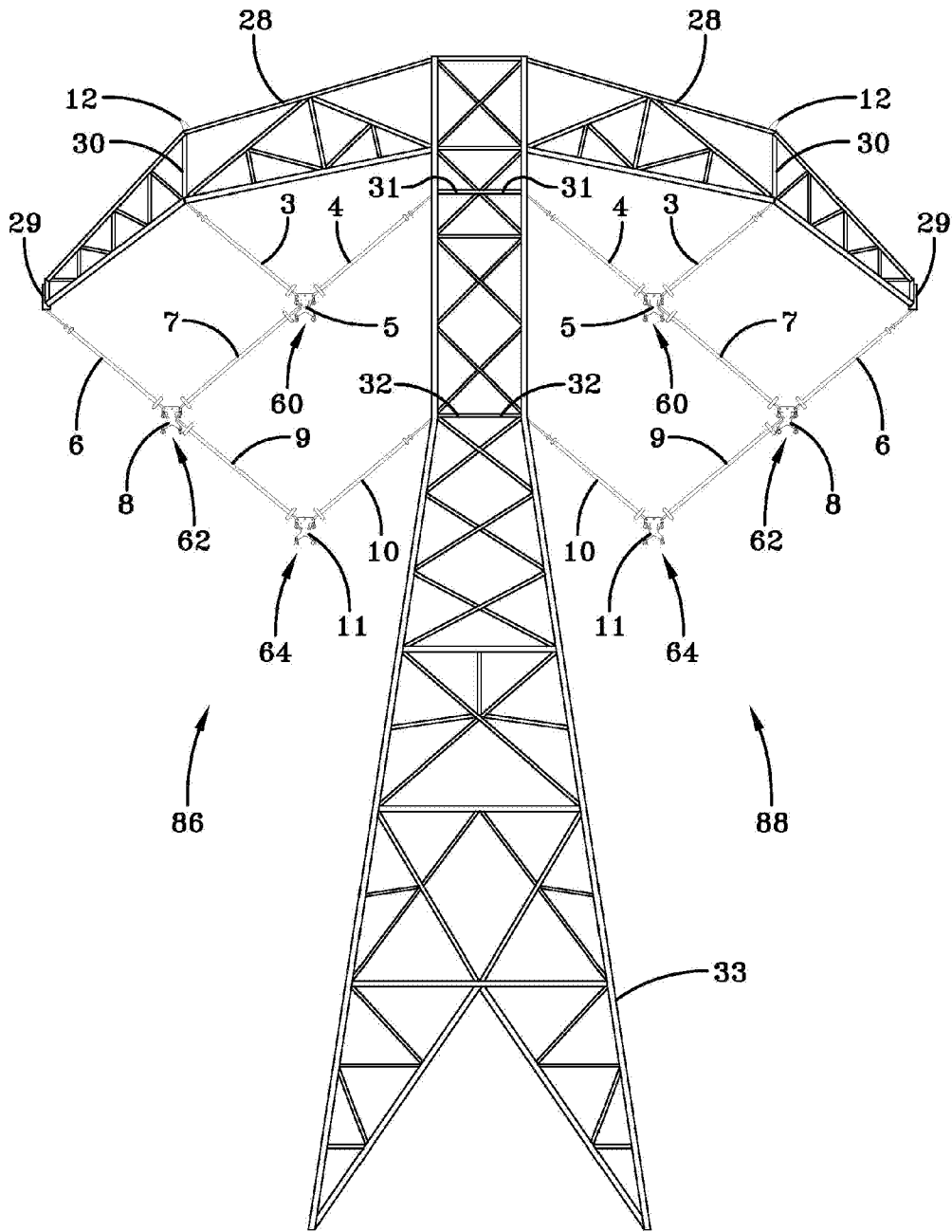

FIG-6

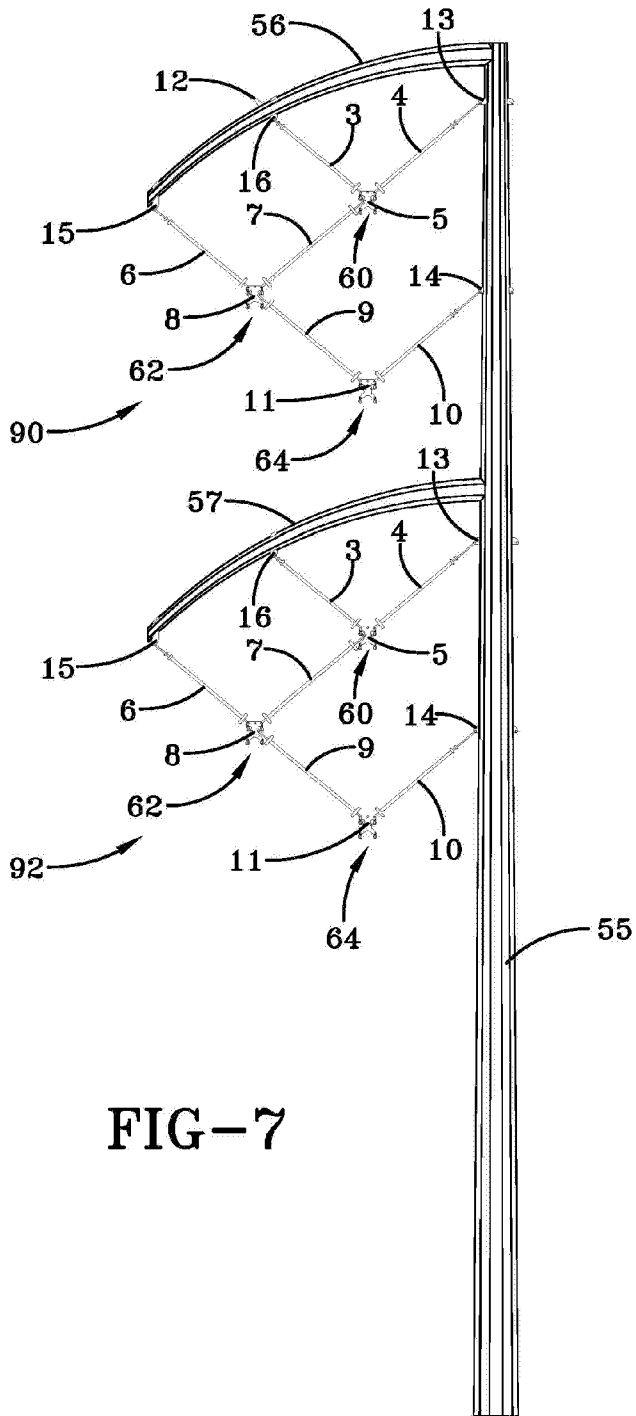

FIG-7

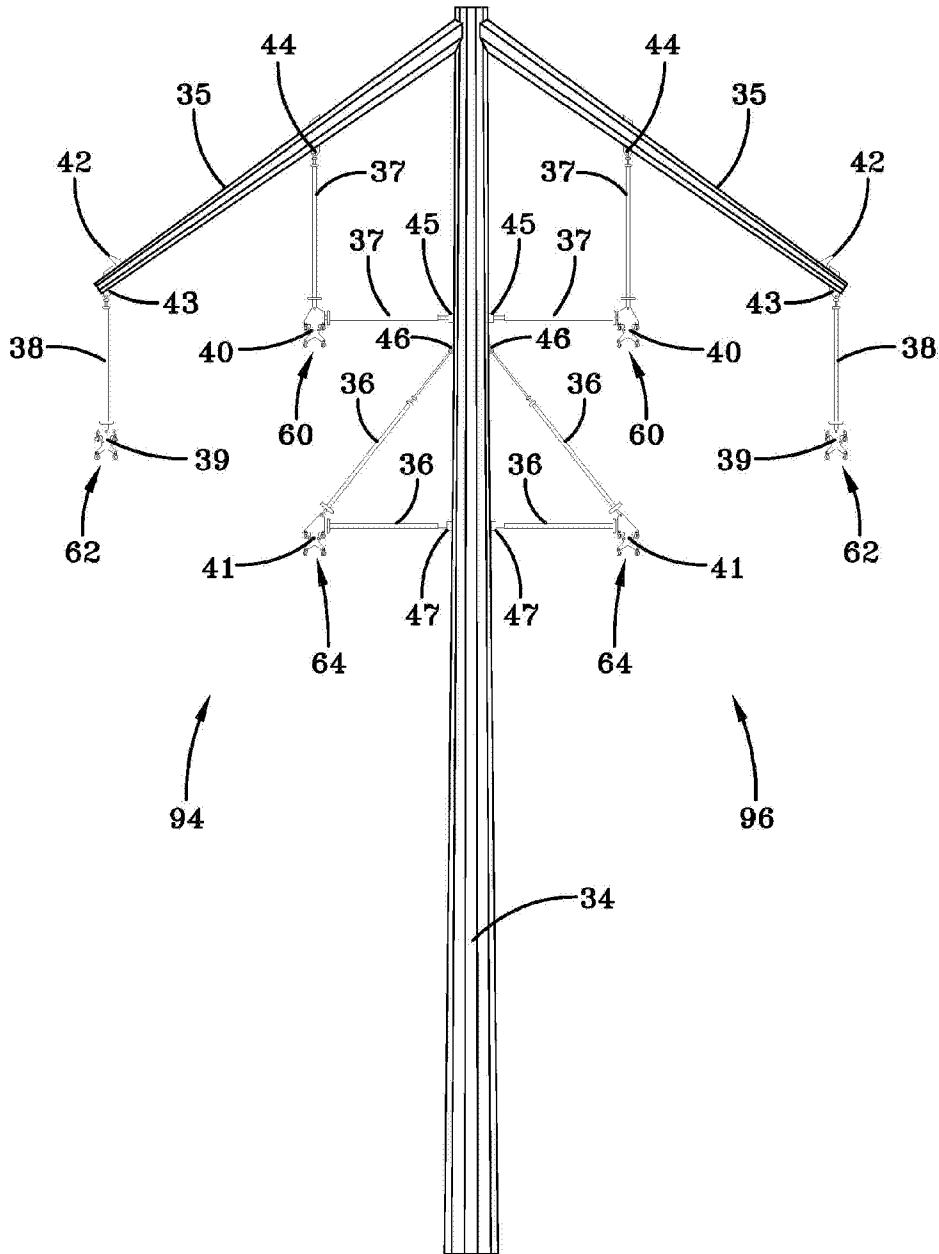

FIG-8

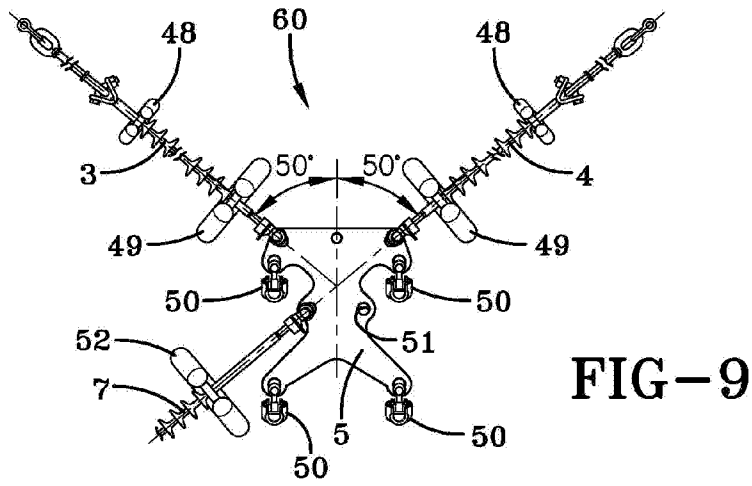

FIG-9

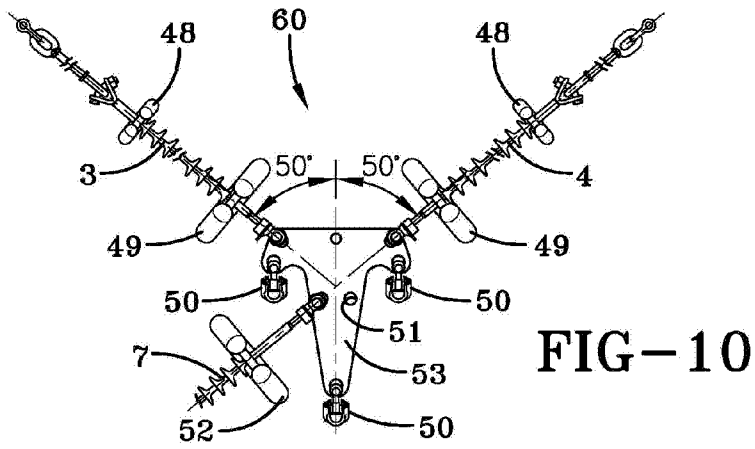

FIG-10

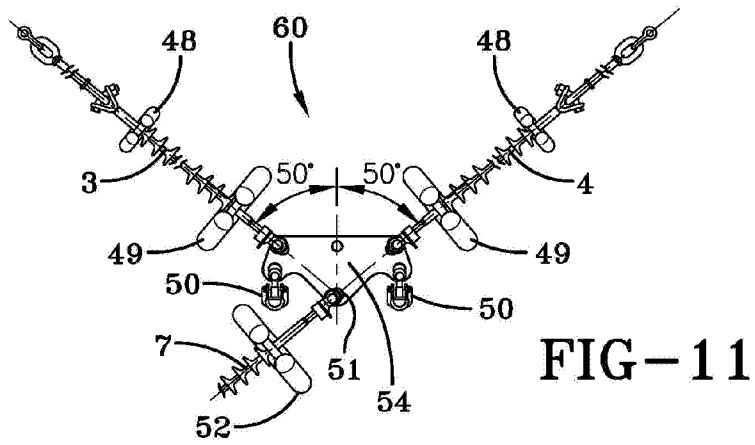

FIG-11