

J. A. SILVER.
MACHINE FOR REMOVING SCALE FROM BOILER TUBES.
APPLICATION FILED AUG. 23, 1905.

919,785.

Patented Apr. 27, 1909.
3 SHEETS—SHEET 1.

Fig. 1.

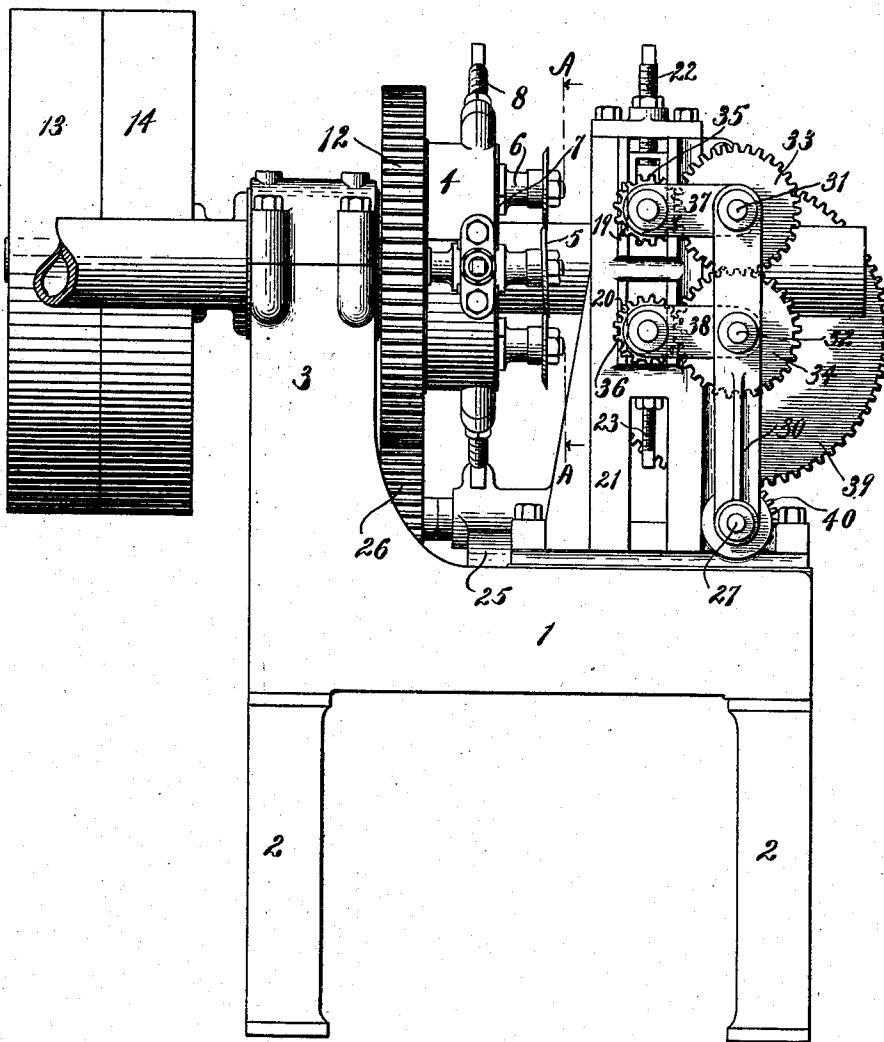

Witnesses:

F. S. Hochenberg
Newry Thome

Inventor:

Joseph A. Silver
by attorneys
Mount Seward

J. A. SILVER.
 MACHINE FOR REMOVING SCALE FROM BOILER TUBES.
 APPLICATION FILED AUG. 23, 1905.

919,785.

Patented Apr. 27, 1909.
 3 SHEETS—SHEET 2.

Fig. 2.

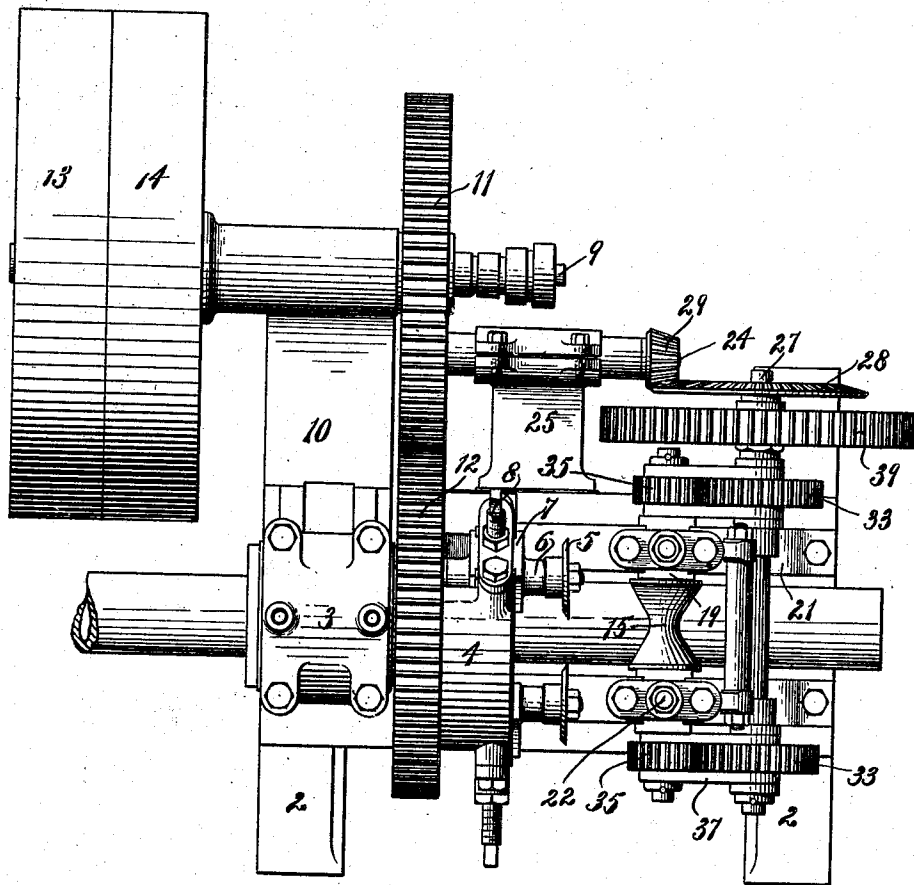

Witnesses:

*F. G. Hackenberg,
 Newry Thieme.*

Inventor:

*Joseph A. Silver
 by attorneys
 Howard Seward*

J. A. SILVER.
 MACHINE FOR REMOVING SCALE FROM BOILER TUBES.
 APPLICATION FILED AUG. 23, 1905.

919,785.

Patented Apr. 27, 1909.
 3 SHEETS—SHEET 3.

Fig. 3.

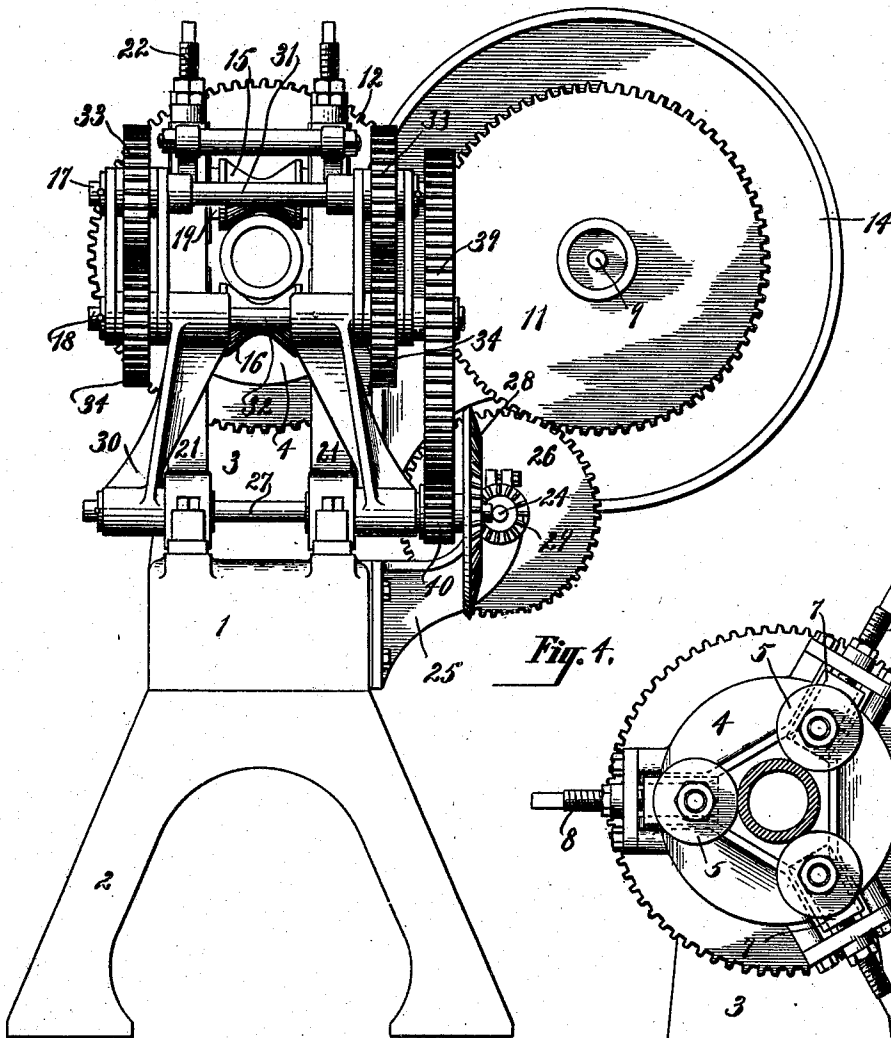
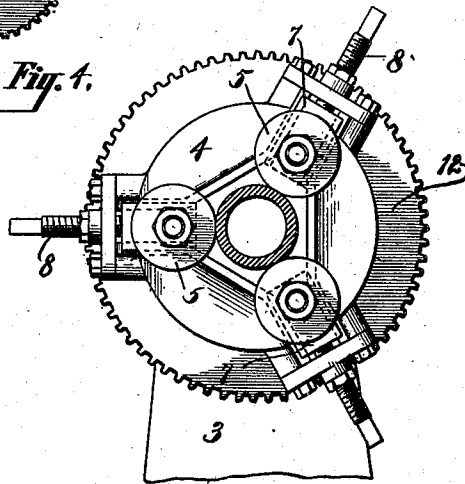

Fig. 4.



Witnesses:

*F. S. Hachenberg,
 Henry Thieme*

Inventor:

*Joseph A. Silver
 by attorneys
 Brown & Broad*

UNITED STATES PATENT OFFICE.

JOSEPH A. SILVER, OF SALT LAKE CITY, UTAH.

MACHINE FOR REMOVING SCALE FROM BOILER-TUBES.

No. 919,785.

Specification of Letters Patent.

Patented April 27, 1909.

Application filed August 23, 1905. Serial No. 275,366.

To all whom it may concern:

Be it known that I, JOSEPH A. SILVER, a citizen of the United States, and resident of Salt Lake City, in the county of Salt Lake and State of Utah, have invented a new and useful Improvement in Machines for Removing Scale from Boiler-Tubes, of which the following is a specification.

The object of my invention is to provide certain improvements in the construction, form and arrangement of the several parts of a tube cleaner whereby the scale which forms on the exterior of boiler tubes may be readily and economically removed.

A practical embodiment of my invention is represented in the accompanying drawings in which—

Figure 1 is a view of the machine in side elevation, a boiler tube being shown in connection with the machine in position to have its scale removed, Fig. 2 is a top plan view of the machine, Fig. 3 is a view in front elevation of the machine, and Fig. 4 is a transverse section taken in the plane of the line A—A of Fig. 1.

The base of the machine is denoted by 1 and it may be provided with suitable supporting legs 2. The head stock which uprises from the base 1, is denoted by 3. A hollow rotary chuck 4 has its shank rotatably mounted in the head stock 3. A plurality of disk cutters 5 are loosely mounted on spindles 6 carried by radially adjustable boxes 7. Each of these boxes 7 is adjustable toward and away from the center of the chuck by means of an adjusting screw 8 so that the disk cutters 5 may be capable of adjustment to suit different sizes of tubes to be operated upon. These cutters have their spindles arranged at a slight angle to the line of movement of the tube through the chuck so as to give the cutters a lead on the tube and thus obtain a clearance in working thereon. Rotary motion is imparted to the chuck from a driving shaft 9 mounted in a bracket 10, through a gear 11 on said shaft and a gear 12 on the chuck meshing therewith. This drive shaft 9 may be provided with the usual fast and idler pulleys 13, 14.

The means which I have shown for feeding the tube to be cleaned through the chuck and head stock is constructed, arranged and operated as follows. The upper and lower feed rolls 15, 16 have their shafts 17, 18, mounted in vertically adjustable boxes 19, 20 in side frames 21 uprising from the base 1. An ad-

justing screw 22 is arranged to adjust the upper feed roll 15 and an adjusting screw 23 is arranged to adjust the lower feed roll 16. These feed rolls may thus be adjusted into position to firmly engage the tube to be cleaned and properly feed it to the disk cutters. These feed rolls are driven from the gear 11 of the drive shaft as follows. A short shaft 24 is carried by a bracket 25, which shaft has a spur gear 26 meshing with the spur gear 11. A cross drive shaft 27 is mounted in suitable bearings on the base 1, which shaft has a bevel gear connection 28, 29 with the shaft 24. A rocking frame 30 is pivoted on the cross drive shaft 27, which rocking frame carries upper and lower cross shafts 31, 32, in substantially the same horizontal planes as the shafts 17, 18 of the upper and lower feed rolls. These two shafts 31, 32 are provided with two sets of spur gears 33, 34, which mesh with each other. The upper and lower shafts 17, 18 are provided with two sets of gears 35, 36, which mesh with the two sets of gears 33, 34 above referred to. These gears are kept in contact irrespective of the adjustment of the feed rolls by upper and lower connecting links 37, 38, mounted on the floating end of the rocking frame. The lower cross shaft 32 of the rocking frame 30 is provided with a spur gear 39 which meshes with a pinion 40 fast to the cross shaft 27.

The relative sizes of the several gears mentioned are such as to insure the feeding of the tube through the cutters at the proper speed and also for rotating the chuck and thereby the cutters around the tube at the proper speed to produce the thorough removal of the scale from the periphery of the tube.

It will be seen from the above description that the cutters and the feed rolls may be adjusted to suit tubes of varying diameters and that the said tubes may be passed through the machine rapidly and easily.

What I claim as my invention is:

1. A machine for removing scale from boiler tubes comprising a rotary hollow chuck, radially adjustable boxes therein, spindles carried by the boxes arranged at a slight angle to the line of movement of the tube through the chuck and disk cutters loosely mounted on said spindles.

2. In a machine for removing scale from boiler tubes, feed rolls mounted therein and movable toward and from each other, a com-

mon drive shaft, a rocking frame pivoted at
one end around the drive shaft, link systems
provided at the floating end of the rocking
frame and connected to the feed rolls, and
5 gear transmission means between the said
drive shaft and the rolls, comprising gears
located on the rolls, the axes of the pivotal
points of the links and rocking arm and on
the drive shaft.

In testimony, that I claim the foregoing as 10
my invention, I have signed my name in
presence of two witnesses, this 17th day of
August 1905.

JOSEPH A. SILVER.

Witnesses:

H. S. YOUNG,
EDGAR S. HILLS.